

MORELATO

E B A N I S T E R I A I T A L I A N A

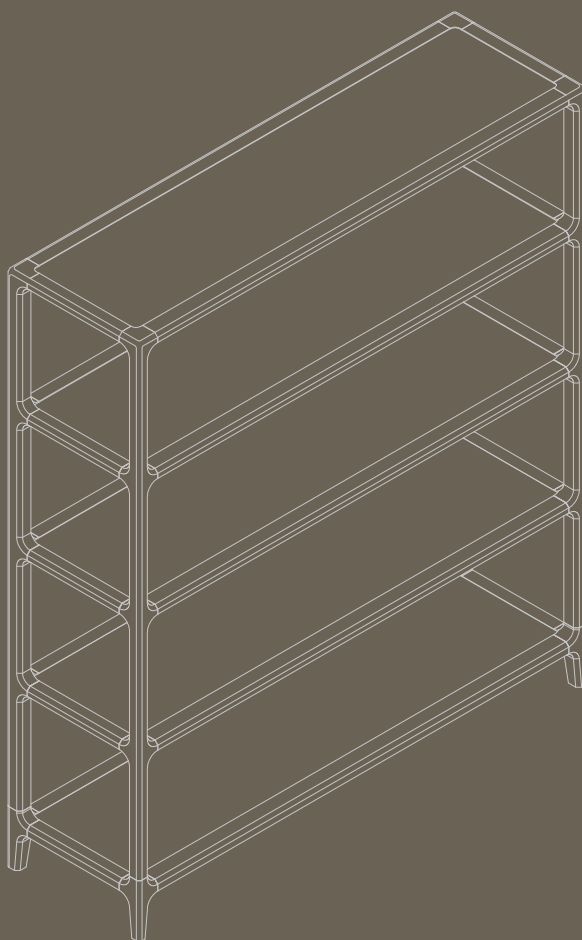

**BELLAGIO COLLECTION
2018**

BETWEEN HISTORICAL RESEARCH AND CLASSICS OF TOMORROW

TRA RICERCA STORICA E CLASSICI DI DOMANI

*“We were raised with the idea that
if you want to make something
you must know how to do it”*

*“Siamo cresciuti con l’idea che per
creare bisogna saper fare”*

Famiglia Morelato

This is the third generation of Morelato family specializing in fine woodcraft. We use precious woods in order to produce handcrafted iconic and functional furniture. The experience we gathered through the years, allows us to produce furniture redefining classicism in a unique contemporary way.

Da tre generazioni siamo specializzati nell’arte dell’ebanisteria; produciamo con essenze pregiate mobili artigianali iconici e funzionali. La grande esperienza accumulata in decenni di produzione del mobile classico, oggi ci permette di realizzare arredi che reinventano la classicità ridefinendola in chiave moderna.

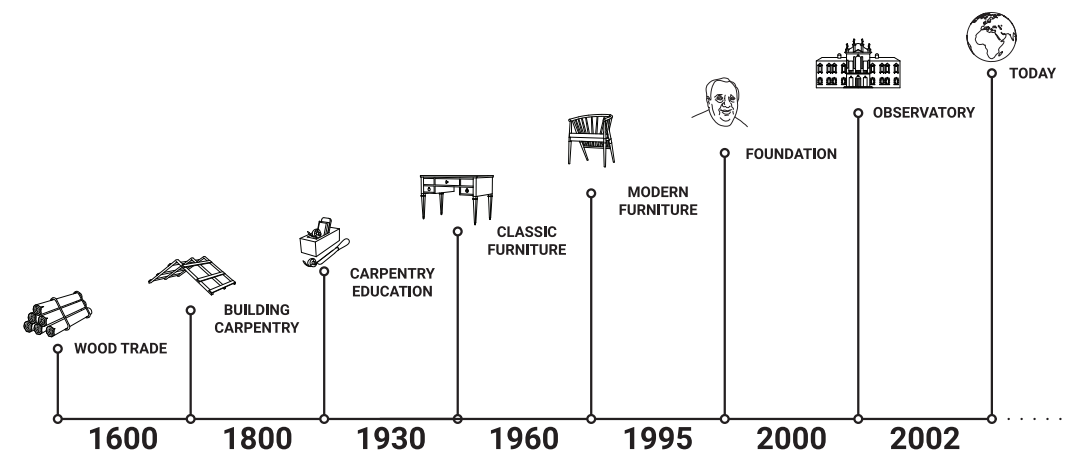



THE BELLAGIO COLLECTION

DESIGN BY LIBERO RUTILO & MAAM

The Bellagio Collection features strong and refined details, such as chamfers and taperings, adding simplicity and appeal. Angled bevels make the structure thinner and lighter, delicate though resistant. These are extremely versatile pieces, apt to furnish a variety of environments, from sober and sophisticated rooms to the most glamorous and exclusive spaces. Their essential shapes, interpreted by contemporary timeless design, are enhanced by the highest quality craftsmanship of leather and wood.

La Collezione Bellagio, attraverso le sue bisellature e rastremature, esprime un carattere deciso e raffinato ma al contempo semplice e di grande appeal. Le Smussature a taglio inclinato degli spigoli, assottigliando e alleggerendo la forma delle strutture, le rendono esili a prima vista ma in realtà resistentissime nel tempo. Ne conseguono dei mobili estremamente versatili, ideali per arredare ambienti disparati, dal sobrio e raffinato fino al più glamour ed esclusivo. Le sue linee essenziali declinate in un design contemporaneo e senza tempo sono impreziosite dalla qualità delle lavorazioni artigianali del legno e della pelle.







BELLAGIO CHAIR



Chair made of ash wood with upholstered seat.

Sedia in legno di frassino con seduta imbottita.

H 79 / L 50 / P 52

Design: Libero Rutilo

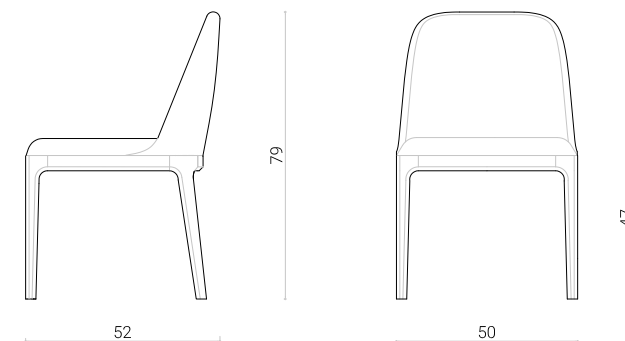

5104/F



BELLAGIO STOOL



Bar stool made of ash wood with upholstered seat.

Sgabello bar in legno di frassino con seduta imbottita.

H 94 / L 41 / P 47

Design: Libero Rutilo

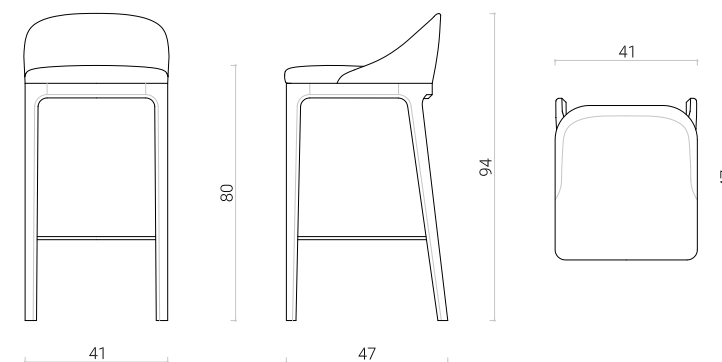

5333/F



ITALO TABLE



Table made of ash wood with marble top and brass tips.

Tavolo in marmo con basamento in legno di frassino e puntali in ottone.

H 75 / L 210 / P 100 *

* su misura a richiesta / custom size on demand

Design: MAAM

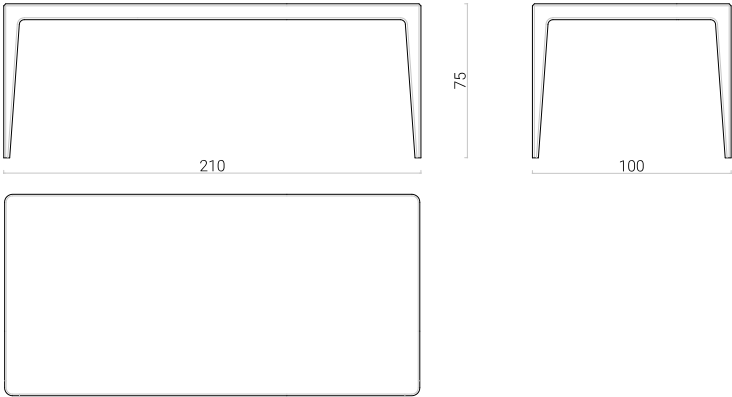

5728/F



BELLAGIO SIDEBOARD



Sideboard made of ash wood with wood or leather doors and glass shelves.

Credenza in legno di frassino con ante in legno o pelle e ripiani in vetro. H

H 85 / L 215 / P 55

Design: Libero Rutilo

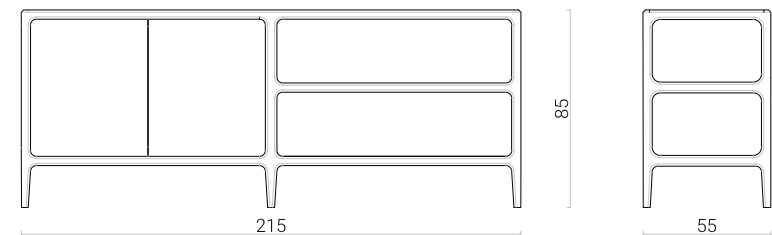

1101/F



BELLAGIO BOOKCASE



Bookcase made of ash wood with glass shelves.

Libreria in legno di frassino con ripiani in vetro o pietra.

H 180 / L 160 / P 44 *

* su misura a richiesta / custom size on demand

Design: Libero Rutilo

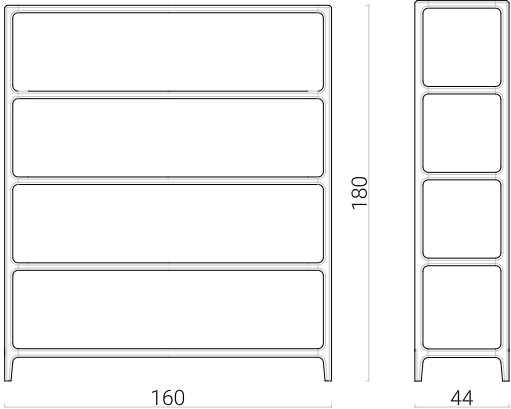

6201/F



BELLAGIO CHEST OF DRAWERS



Dresser made of ash wood with three drawers.

Comò in legno di frassino con tre cassetti.

H 85 / L 130 / P 54

Design: Libero Rutilo

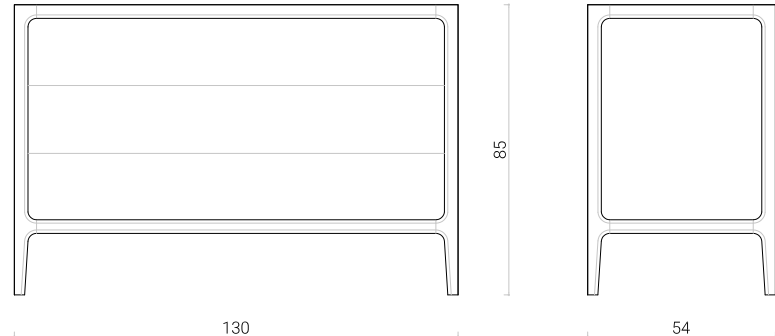

1201/F



BELLAGIO BED



Bed made of ash wood with upholstered headboard.

Letto in legno di frassino con testiera imbottita.

H 90 / L 213 / P 183 *

** su misura a richiesta / custom size on demand*

Design: Libero Rutilo

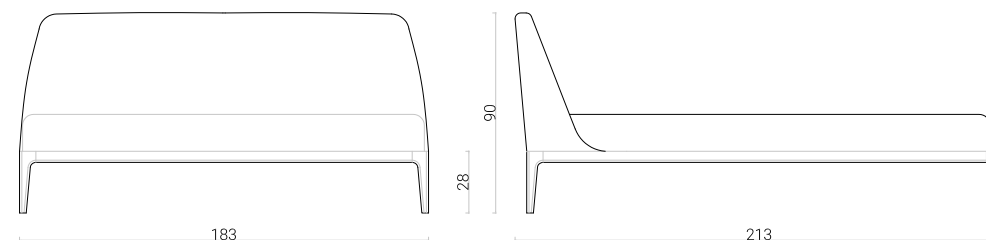

2807/F



BELLAGIO BEDSIDE TABLE



Bedside table made of ash wood with two glass shelves or one drawer.

Comodino in legno di frassino con due ripiani in vetroo con cassetto.

H 55 / L 54 / P 39

Design: Libero Rutilo

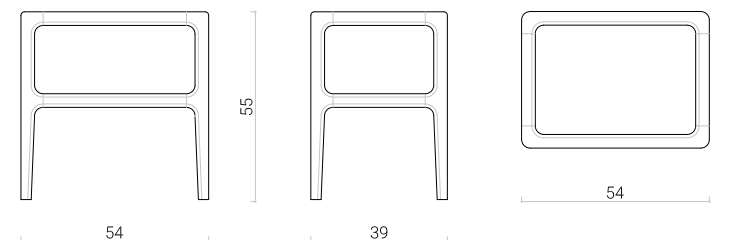

1301/F

BELLAGIO WRITING DESK



Writing desk made of ash wood with leather flapping top and one drawer. .
Scrittoio in legno di frassino con piano ribalta in pelle e cassetto porta oggetti.

H 88 / L 135 / P 66

Design: Libero Rutilo

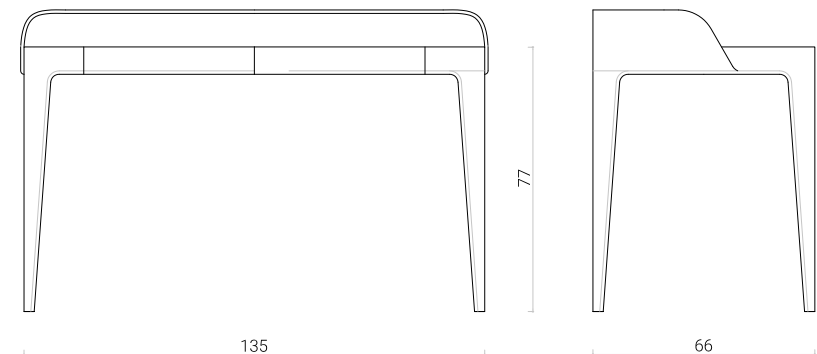

5002/F





JENNY CHAIR 5102/F

DESIGN: MAAM



Chair made of turned ash wood with upholstered seat /
Sedia in legno di frassino con seduta imbottita.
L 55 / P 48 / H 77

ICARO BAR STOOL 5304/F

DESIGN: ITAMAR HARARI



Bar stool made of ash wood /
Sgabello in legno di frassino.
L 42 / P 39 / H 74

SPIDER TABLE 5729/F

DESIGN: MAAM



Table with glass top and ash wooden base with precious joints /
Tavolo con piano in vetro e basamento in legno di frassino con incastri.
L 200 / P 110 / H 75

ICARO LOW STOOL 5303/F

DESIGN: ITAMAR HARARI



Low stool made of ash wood /
Sgabello basso in legno di frassino.
L 42 / P 39 / H 48

CAMILLA CHAIR 5109/F

DESIGN: FRANCO POLI



Chair made of ash wood with upholstered seat /
Sedia in legno di frassino e seduta imbottita.
L 53 / P 54 / H 72

PERBACCO BOOKCASE 5204/F

DESIGN: ITAMAR HARARI



Bookcase made of ash wood with turned columns /
Libreria in legno di frassino con fianchi a colonne tornite.
L 70 / P 35 / H 186

VERONESE BAR CABINET 1710/F

DESIGN: MAAM



Bar cabinet with two doors and brass base, structure made of ash wood and doors veneered with Maple, Cherry and Ebony /
Mobile bar a due ante con struttura in Ottone e scocca in legno di frassino, ante in Ebano, Ciliegio e Acero.
L 133 / P 47 / H 150

TAOS VALET 0420/F

DESIGN: MARCO BAXADONNE



Valet made of turned ash wood with brass hinges /
Servo muto in legno di frassino tornito con particolari cerniere in ottone.
L 108 / P 4 / H 180

MORELATO

E B A N I S T E R I A I T A L I A N A

Morelato Srl

Loc. Valmorsel, 540 – 37056 Salizzole -
(Verona) ITALY

Tel.: (39) 045 695 40 01

Fax.: (39) 045 695 40 30

morelato@morelato.it

www.morelato.it

