

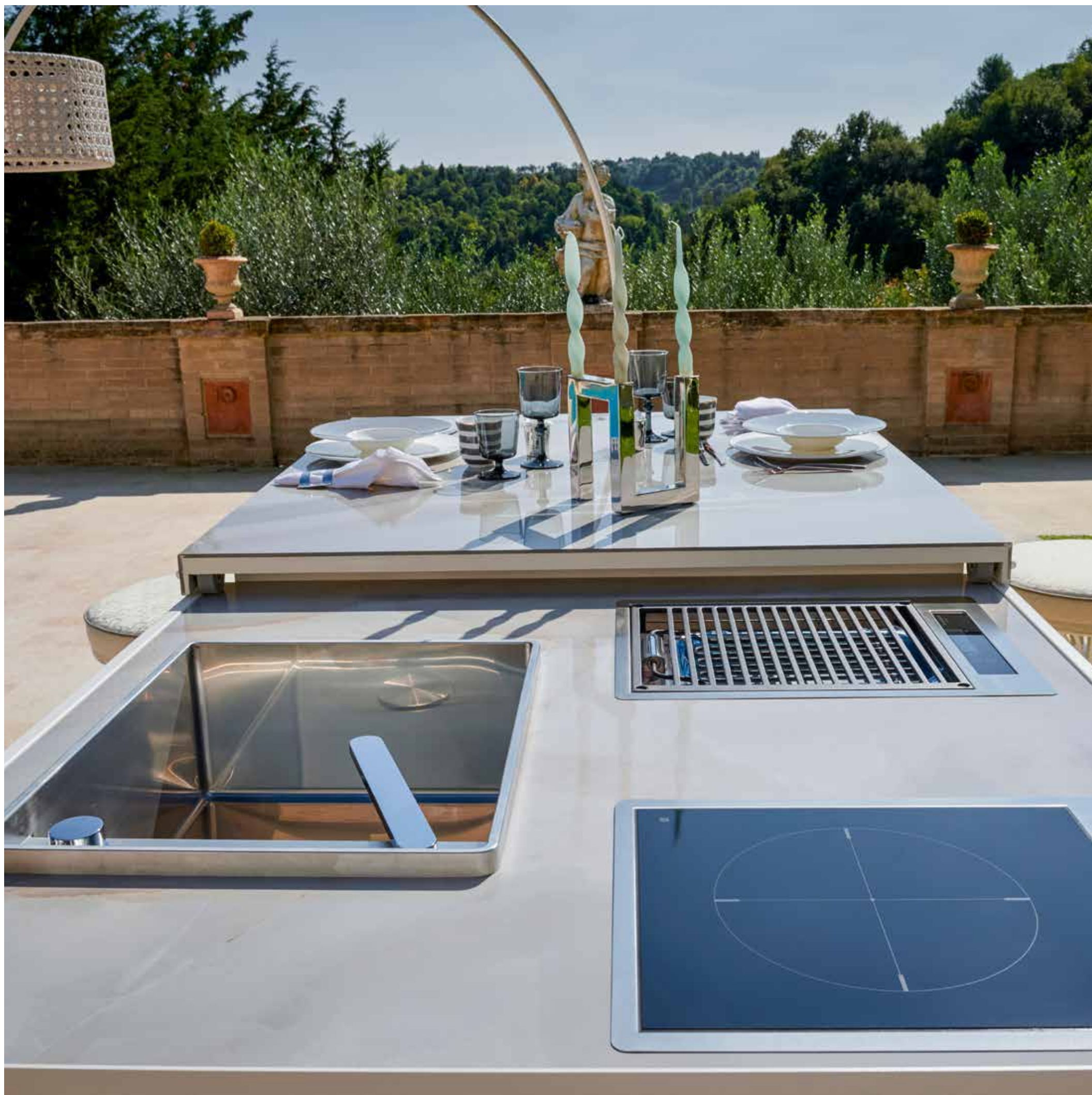

SAMUELE MAZZA
OUTDOOR COLLECTION

KITCHEN APPLIANCES



Enjoy outdoor living in every occasion: this is the soul of Outdoor Kitchens by Samuele Mazza that complete and enhance his glamour furniture proposal. Ease of use, optimal performance, extreme versatility. Different proposals that take care of all the prerogatives that characterize the collection. Unique shapes, precious details, unusual finishes, cutting-edge technology: these are the ingredients for a new kitchens range designed to pave the way for new trends on outdoor luxury furnish.

– BARBECUE
only for outdoor use

Aurora A540i Built in grill

A540i-6EAP-EC



Superior design and engineering power the Aurora's unparalleled performance. The Aurora delivers cooking versatility, durability and longevity in a beautifully crafted machine.

KEY FEATURES:

- Diamond Sear Cooking Grids
- Analog Thermometer
- Hot Surface Ignition
- Comfort touch knobs
- Halogen Interior Lights
- Cast Stainless Steel Burner

- Gourmet Face
- **SPECIFICATIONS:**
- Cooking Surface: 76w x 46d cm
- Warming Rack: 76w x 20d cm
- Main burners: 18 KW
- Backburner: 5 KW
- Cut out Dimensions: 81w x 50d x31h cm

Aurora A660i Built in grill

A660i-6EAP-EC



Superior design and engineering power the Aurora's unparalleled performance. The Aurora delivers cooking versatility, durability and longevity in a beautifully crafted machine.

KEY FEATURES:

- Diamond Sear Cooking Grids
- Analog Thermometer
- Hot Surface Ignition
- Comfort touch knobs
- Halogen Interior Lights
- Cast Stainless Steel Burner

- Gourmet Face
- Available with Magic View Window
- **SPECIFICATIONS:**
- Cooking Surface: 76w x 56d cm
- Warming Rack: 76w x 20d cm
- Main burners: 22KW
- Backburner: 5 KW
- Cut out Dimensions: 81w x 60d x31h cm



REGAL I DROP-IN GRILL

Aurora A790i Built in grill

A790i-6EAN*-W (Optional Magic View Window shown)



Superior design and engineering power the Aurora's unparalleled performance. The Aurora delivers cooking versatility, durability and longevity in a beautifully crafted machine.

KEY FEATURES:

- Diamond Sear Cooking Grids
- Analog Thermometer
- Hot Surface Ignition
- Comfort touch knobs
- Halogen Interior Lights
- Cast Stainless Steel Burner

- Gourmet Face
- Available without Magic View Window
- **SPECIFICATIONS:**
- Cooking Surface: 91w x 56d cm
- Warming Rack: 91w x 20d cm
- Main burners: 26 KW
- Backburner: 6 KW
- Cut out Dimensions: 96w x 60d x31h cm

Regal I Drop-In Grill

34-S2S1N*-A (with Backburner Rotisserie shown)



Uniquely and architecturally designed, this exclusive Drop In style grill will make your outdoor kitchen look and feel like a unique wonder. They are exclusively designed, space conscious unit for a unique look.

KEY FEATURES:

- Cast Stainless Steel Burners
- Features the new Diamond Sear trapezoid cooking grids
- Available without rotisserie backburner (Model # 34-S1S1N-A)

SPECIFICATIONS:

- Cooking Surface: 76w x 46d cm
- Warming Rack: 76w x 20d cm
- Main burners: 19 KW
- Backburner: 6.4 KW
- Cut out Dimensions: 105w x 52d x46h cm



FOBQ 1000 G X

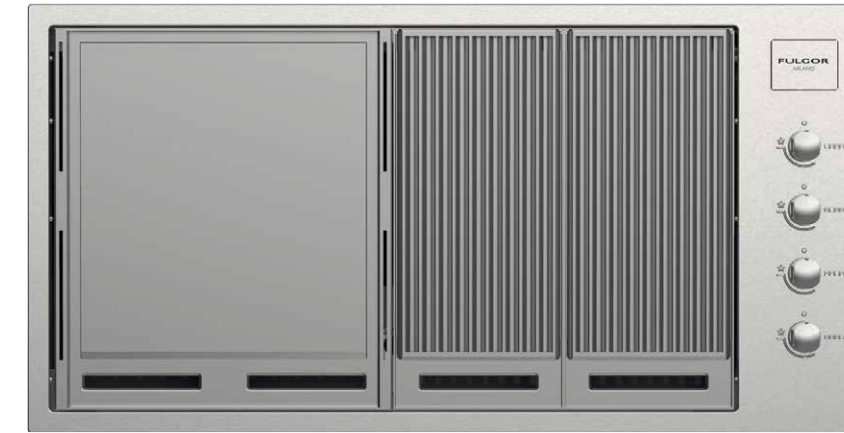

- ◆ In AISI 316 stainless steel 316 (suitable for salty environments)
- ◆ Side controls
- ◆ Steel knobs
- ◆ 4 gas burners, can be used both with NG and LPG, total power 14 kW
- ◆ 2 stainless steel grills
- ◆ 1 Stainless steel surface (teppan yaki cooking)
- ◆ Removable drip trays for fat, oil and cooking residue

- ◆ Temperature sensor (only on cover FOBQ HL 1000 X)
 - ◆ Electronic battery ignition
- Accessories upon request:
- ◆ FOBQ LL 1000 X slim cover with feet
 - ◆ FOBQ HL 1000 X high cover for closed cooking

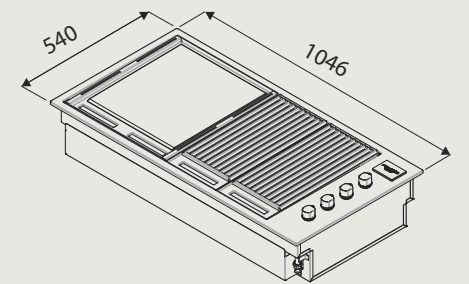
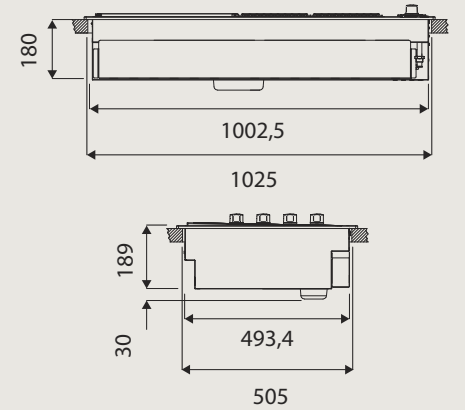

COVERS

FOBQ HL 1000 X



HIGH LID

For oven-style cooking
Thermometer

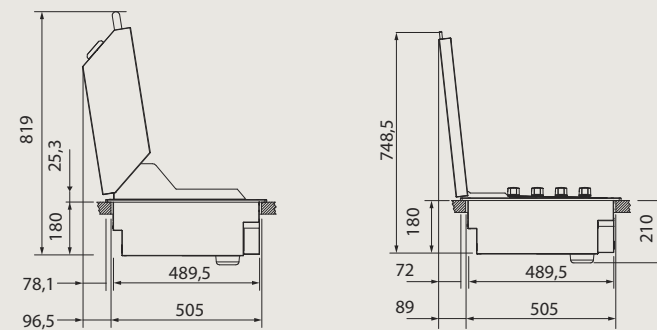

FOBQ LL 1000 X



SLIM LID

In AISI 316 stainless steel
with foot supports

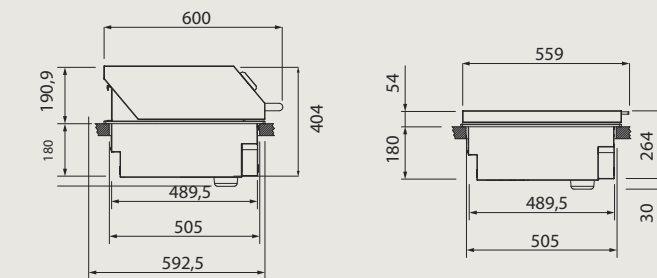

BQ GRT X

Stainless steel grill
(consisting of 2 parts
+ gas deflector)



BQ TY X

Stainless steel
teppan yaki



FOBQ 1000 G X

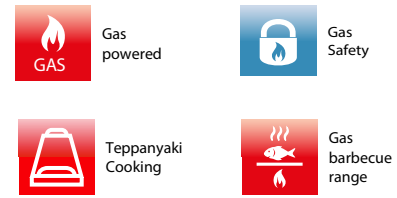
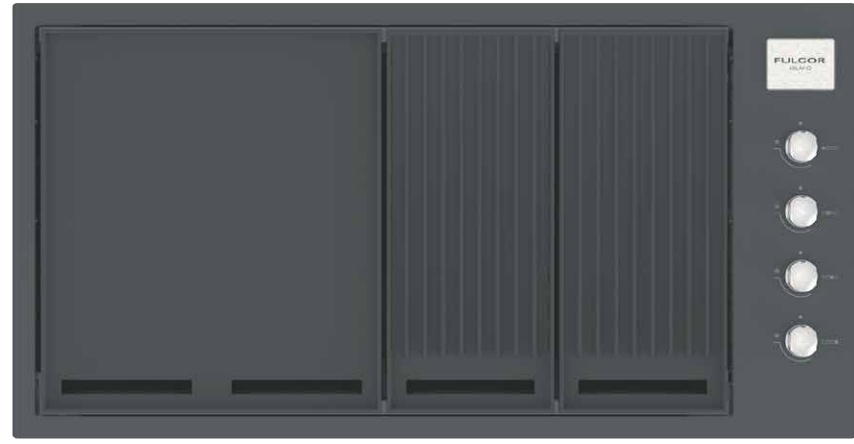

- ◆ In matt black enamelled steel
- ◆ Side controls
- ◆ Steel knobs
- ◆ 4 gas burners, can be used both with NG and LPG, total power 14 kW
- ◆ 2 cast iron grills
- ◆ 1 cast iron surface (teppan yaki cooking)
- ◆ Removable drip trays for fat, oil and cooking residue

- ◆ Temperature sensor (only on cover FOBQ HL 1000 MBK)
- ◆ Electronic battery ignition
- ◆ Accessories upon request:
 - ◆ FOBQ LL 1000 MBK slim cover with feet
 - ◆ FOBQ HL 1000 MBK high cover for closed cooking

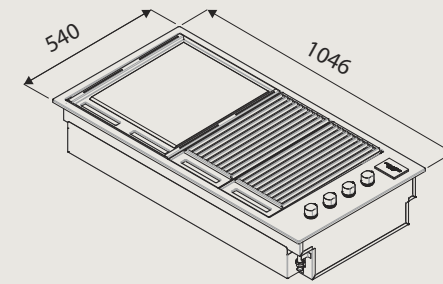
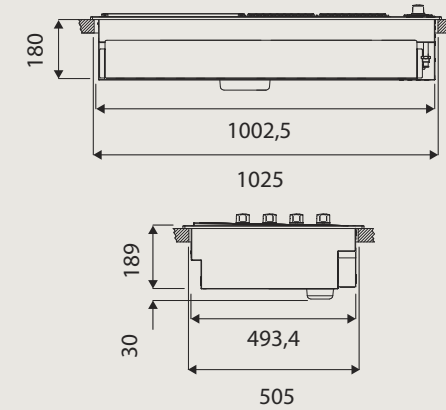

COVERS

FOBQ HL 1000 MBK



HIGH LID

For oven-style cooking
Thermometer



SLIM LID

In steel
with foot supports



FOBQ LL 1000 MBK

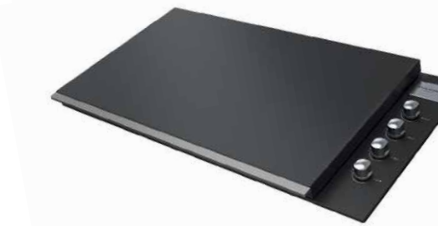

BQ GRT CAST

Cast iron grill
(consisting of 2 parts
+ gas deflector)

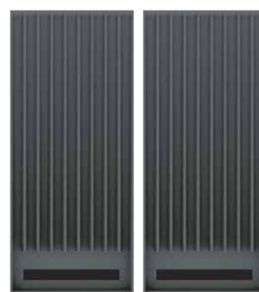

BQ TY CAST

Cast iron
teppan yaki

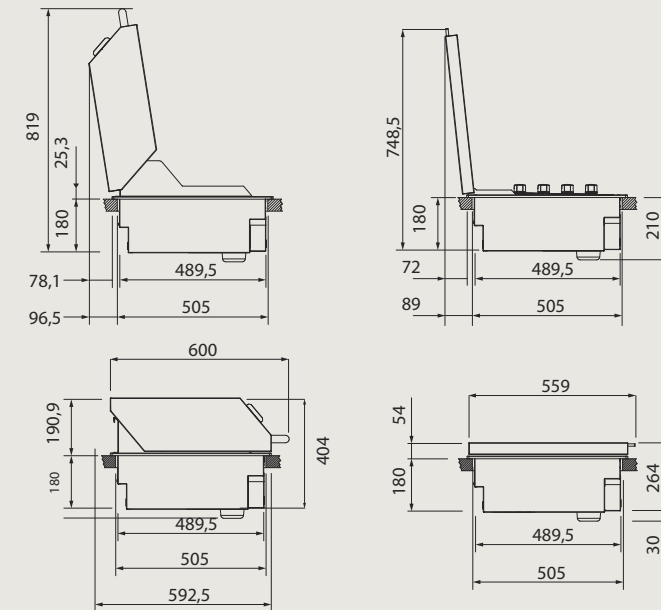
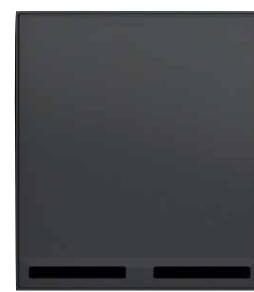

B70400WH - UL

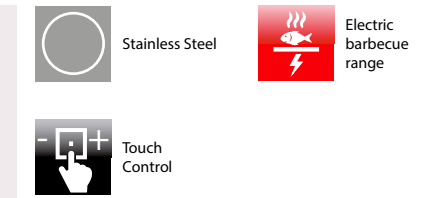

2 BURNER
753mm x 533mm
(2) 1500 Watt Elements

- ◆ Split faceted double lined lid
- ◆ Lids can lock together or open separately
- ◆ Rectangular flange
- ◆ Removable Lid helps maintain heat and keeps food juicy
- ◆ Non-stick grate is dishwasher safe
- ◆ Precision control cooks food to the perfect temperature
- ◆ Concealed heating element eliminates flare-ups
- ◆ The hidden drip tray traps drippings and adds flavor to food

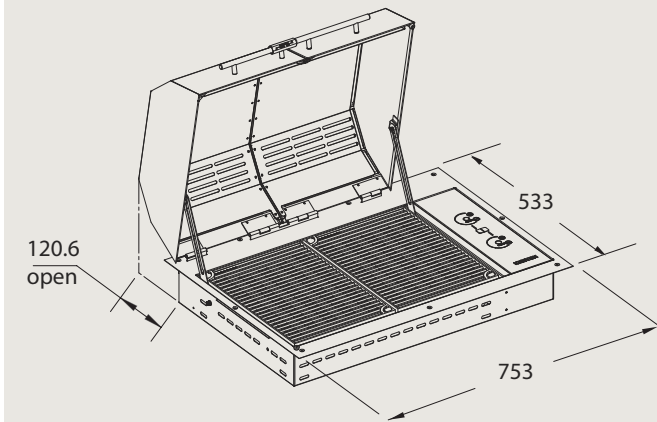

B70430

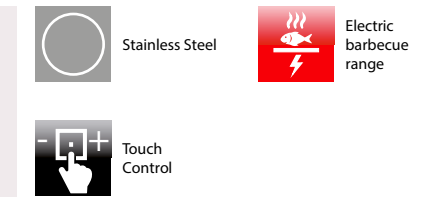

3 BURNER
1039mm x 533mm
(3) 1500 Watt Elements

- ◆ Split faceted double lined lid
- ◆ Lids can lock together or open separately
- ◆ Single piece lid available
- ◆ Rectangular flange
- ◆ Removable Lid helps maintain heat and keeps food juicy
- ◆ Non-stick grate is dishwasher safe
- ◆ Precision control cooks food to the perfect temperature
- ◆ Concealed heating element eliminates flare-ups
- ◆ The hidden drip tray traps drippings and adds flavor to food

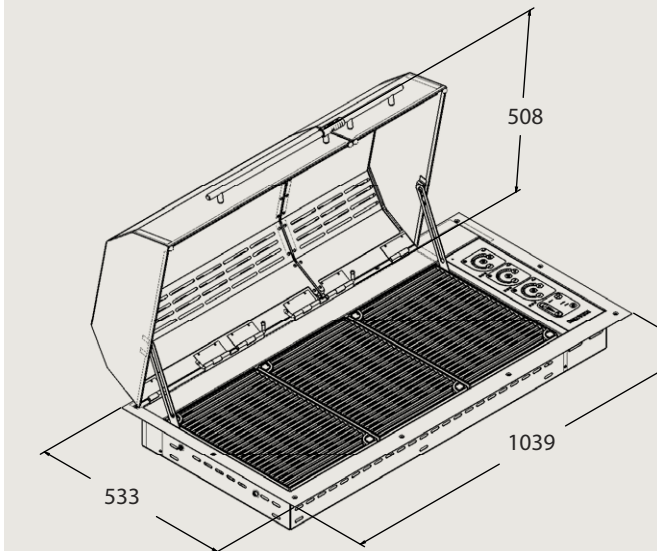

BARBECUE WOOD CHARCOAL



Technical data

DIMENSIONS/WEIGHT:
CM: 90 W X 50 D X 21 H

- ◆ Stainless steel structure
- ◆ Ash drawer made of stainless steel
- ◆ Removable stainless steel charcoal grill
- ◆ Barbecue cover made of stainless steel

DIMENSIONS OF COOKING AREA:
CM: 80 X 40

DIMENSIONS/WEIGHT:
CM: 50 W X 50 D X 21 H

- ◆ Stainless steel structure
- ◆ Ash drawer made of stainless steel
- ◆ Removable stainless steel charcoal grill
- ◆ Barbecue cover made of stainless steel

DIMENSIONS OF COOKING AREA:
CM: 40 X 40

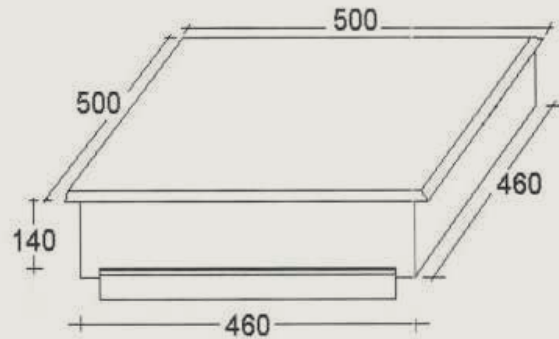
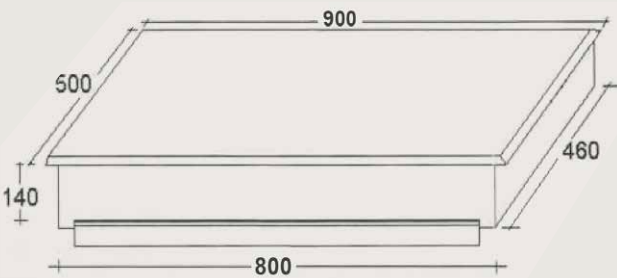

– GRILL and TEPPAN YAKI

CPH 401 BQ TC X

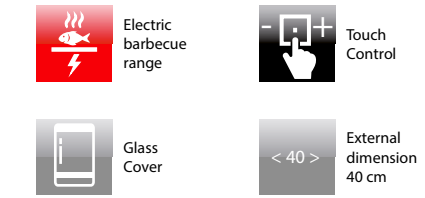

ELECTRIC BARBECUE GRILL
 Stainless steel finish
PERFORMANCE
 Barbecue with lava stone inside
 Grilling with water inside
FEATURES
 Touch controls
 12-Level electronic programming
 Cooking timer up to 99 min.

Operation indicator
 Removable, stainless steel tub
 Optional flush or semi flush top installation
SAFETY
 Safety switch
 (to prevent accidental use)
STANDARD ACCESSORIES
 Black tempered glass cover
 Power cord with plug

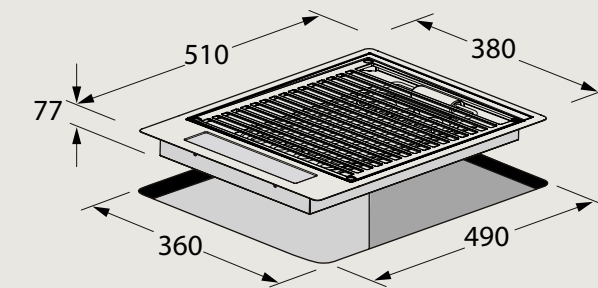

CPH 402 ID TY TC X

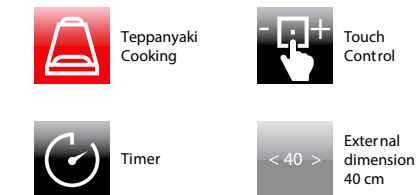

TEPPAN YAKI INDUCTION HOBS
 Stainless steel finish
PERFORMANCE
 2 independent cooking areas
 End-of-cooking timer for each area
 End-of-cooking alarm
FEATURES
 Touch controls
 Digital power level indicator
 10 mm thick stainless steel plate

Food residues collection channel surrounding the plate
 Optional flush and semi-flush top installation
SAFETY
 Safety switch
 (to prevent accidental use)
 Residual heat indicator (H)
STANDARD ACCESSORIES
 Power cord and plug

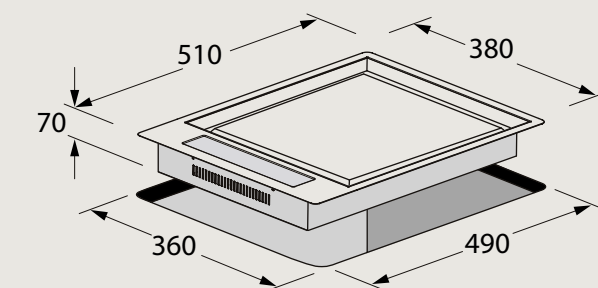

– COOKER HOBS

SINGLE SIDE BURNER COUNTER TOP



Model Number: 3280

Drops into the top of island. Features include 15,000 BTU's sealed burner, precise flame control valve and stainless steel cover.

SPECIFICATIONS:

- ◆ Burners: 15,000 BTU's
- ◆ Cutout dimensions: 22,5w x 37d cm



CPH 401 GDWK TC X



GAS HOB

PERFORMANCE

4.0 kW Wok burner
DUAL regulation (separate controls)
Special long cooking at a low temperature (up to 4 h)

Automatic burner cut-off timer

Automatic re-ignition

FEATURES

Touch controls

Touch control

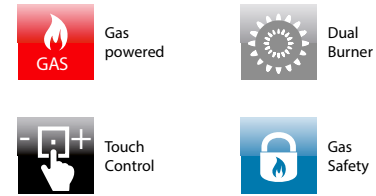

Cast iron grid

SAFETY

Gas detection and stop gas system

Switch to prevent accidental use

Residual heat indicator (H)

STANDARD ACCESSORIES

Cast iron adaptor for Woks

Cast iron reducer for small pans

Power cord with plug

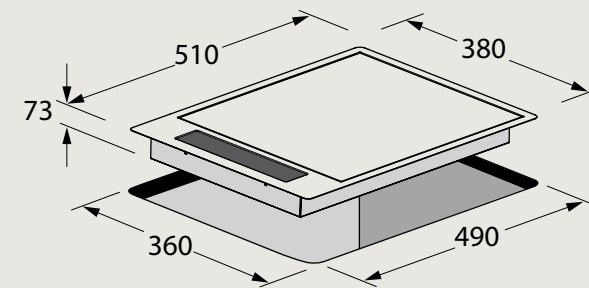

CPH 604 G TC X



GAS HOB

Stainless steel finish

PERFORMANCE

4 Burners

Special long cooking / low temperature function

Automatic burner off timer

Automatic relighting

FEATURES

Touch controls

Cast iron trivets

Optional flush or semi-flush worktop installation

Touch control

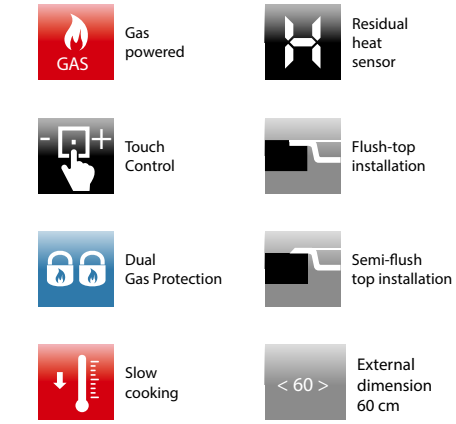

SAFETY

Gas Protekt double step.

Residual heat indicator (H)

STANDARD ACCESSORIES

Cast iron adaptor for Woks

Cast iron reducer for pans with small bases

Power cord with plug

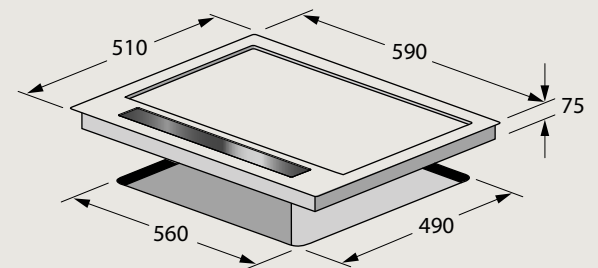

CPH 402 G TC X



GAS HOB

PERFORMANCE

2 Burners
Special long cooking at a low temperature (up to 4 h)

Automatic burner cut-off timer

Automatic relighting

FEATURES

Touch controls

Cast iron grid

Touch control

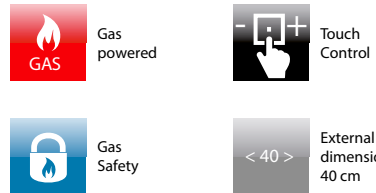

SAFETY

Gas detection and stop gas system

Switch to prevent accidental use

Residual heat indicator (H)

STANDARD ACCESSORIES

Cast iron reducer for small pans

Power cord with plug

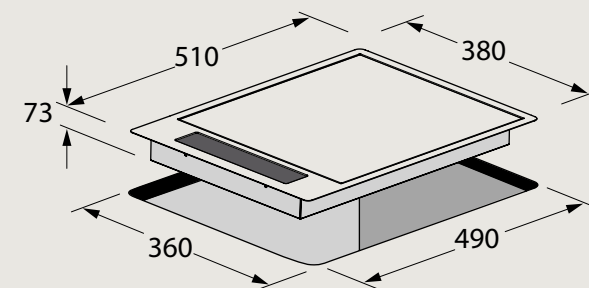

CPH 401 GDWK X



GAS HOB

Stainless steel finish

PERFORMANCE

4.0kW Wok burner

DUAL Regulation

FEATURES

Knobs in Professional stainless steel.

Cast iron grid

Optional flush or semi-flush top installation

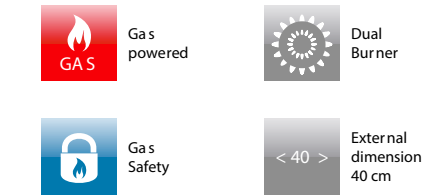

SAFETY

Gas detection and stop gas system

STANDARD ACCESSORIES

Cast iron adaptor for Woks

Cast iron reducer for small pans

Power cord with plug

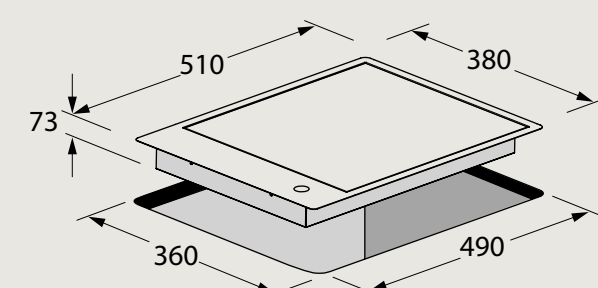

CPH 402 G X



GAS HOB
Stainless steel finish
PERFORMANCE
2 gas burners
FEATURES
Knobs in Professional stainless steel.
Cast iron grid
Optional flush or semi-flush top installation

SAFETY
Gas detection and stop gas system
STANDARD ACCESSORIES
Cast iron reducer for small pans
Power cord with plug

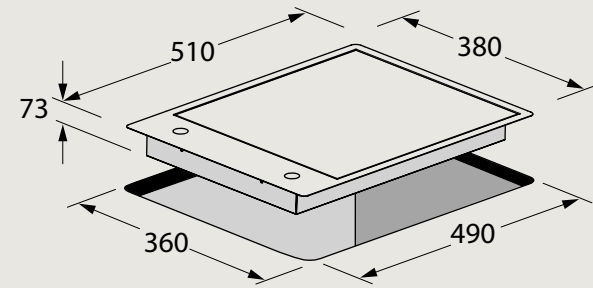

CPH 402 ID TC X



Touch control

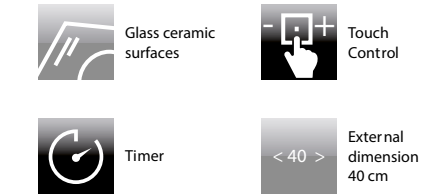

INDUCTION HOB
Glass ceramic surface with stainless steel frame
PERFORMANCE
2 independent cooking areas
End-of-cooking timer for every hotplate
End-of-cooking alarm
FEATURES
Touch controls

Digital power level indicator
Optional flush and semi-flush top installation
SAFETY
Safety switch
(to prevent accidental use)
Residual heat indicator (H)
STANDARD ACCESSORIES
Scraper to clean surfaces
Power cord and plug

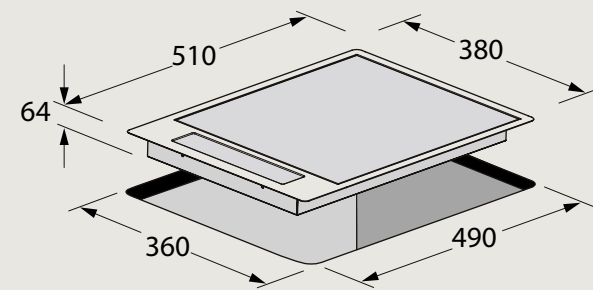

CPH 604 G X

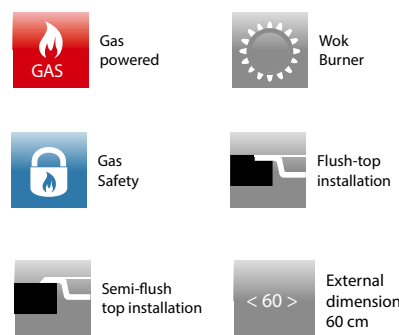
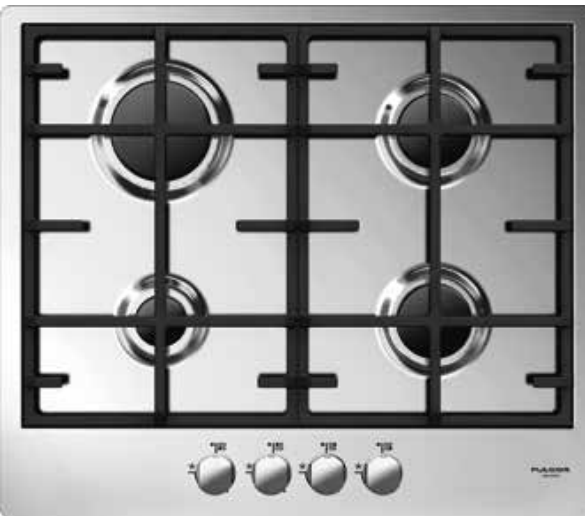

GAS HOB
Stainless steel finish
PERFORMANCE
4 gas burners
FEATURES
Electronic ignition
Steel knobs
Cast iron trivets
Optional flush or semi-flush top installation

SAFETY
Gas detection and stop gas system
STANDARD ACCESSORIES
Cast iron reducer for pans with small bases
Power cord with plug

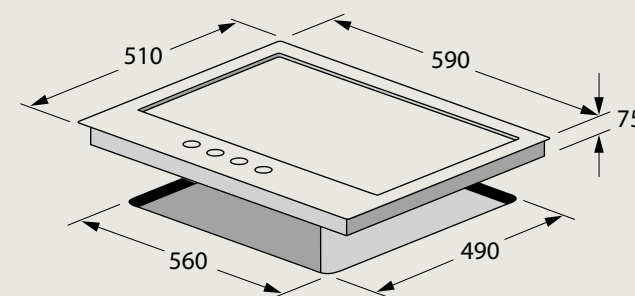

CH 604 ID TS BK

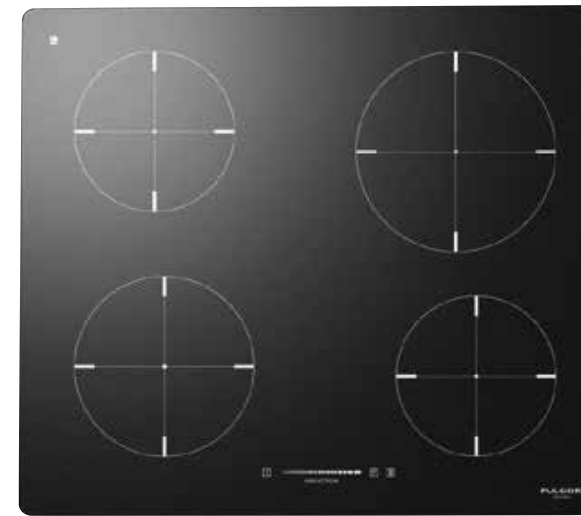

Also available in white finish

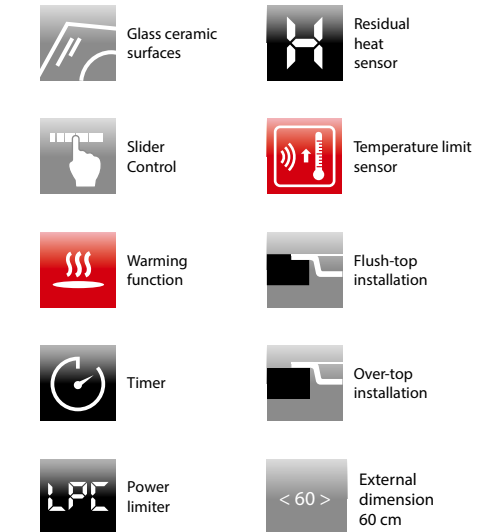

INDUCTION HOB
Glass ceramic surface
PERFORMANCE
4 cooking areas
LPC limiting power consumption (removable on request)
Automatic heating
End-of-cooking timer
Pause function
FEATURES
Centralised slider touch controls
Optional flush-top installation

SAFETY
Saucepan detection sensor
Safety switch
(for preventing accidental use)
Residual heat indicator (H)
Automatic power off with temperature sensor
STANDARD ACCESSORIES
Scraper to clean surfaces

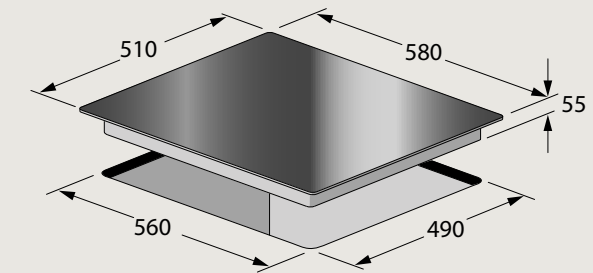

CPH 401 ID X

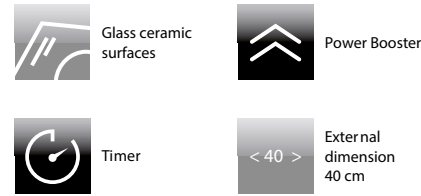

INDUCTION HOB
Glass ceramic finish with stainless steel frame

PERFORMANCE
1 large cooking area
End-of-cooking timer
Booster for rapid heating
Automatic heating
End-of-cooking alarm

FEATURES
Knobs in Professional stainless steel.

Digital power level indicator
Optional flush and semi-flush top installation

SAFETY
Safety lock
(to prevent accidental use)
Residual heat indicator (H)

STANDARD ACCESSORIES
Scraper to clean surfaces
Power cable

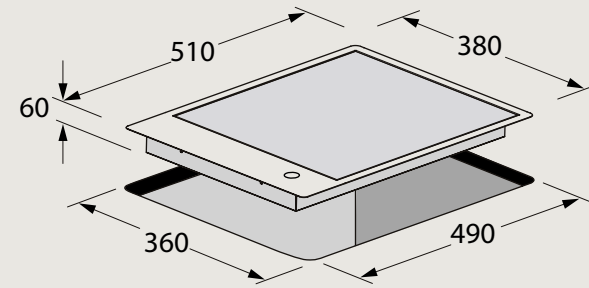

B41573 - UL

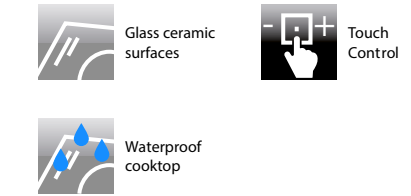
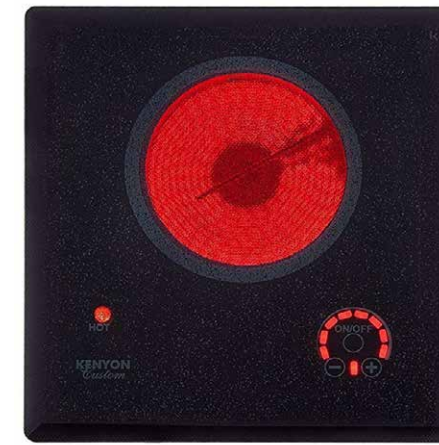

INDUCTION HOB
Waterproof cooktop
Subtly textured surface
(1) 165mm burner @ 1200 watts

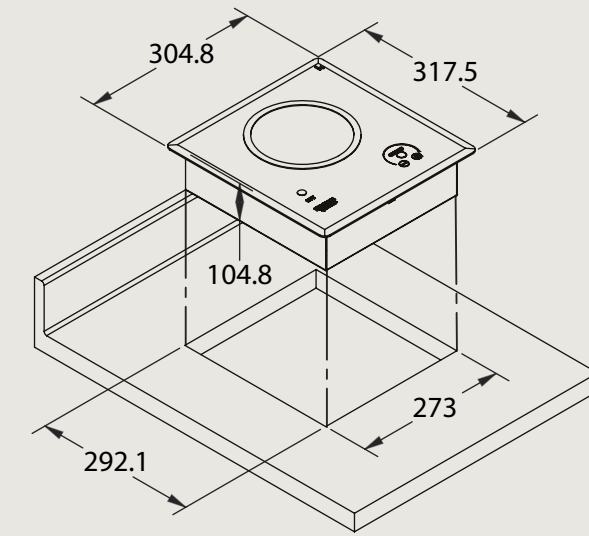

CPH 402 ID X

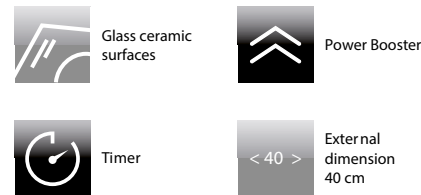

INDUCTION HOB
Glass ceramic finish with stainless steel frame

PERFORMANCE
2 independent cooking areas
End-of-cooking timer
Booster for rapid heating
Automatic heating
End-of-cooking alarm

FEATURES
Knobs in Professional stainless steel.

Digital power level indicator
Optional flush and semi-flush top installation

SAFETY
Safety lock
(to prevent accidental use)
Residual heat indicator (H)

STANDARD ACCESSORIES
Scraper to clean surfaces
Power cable

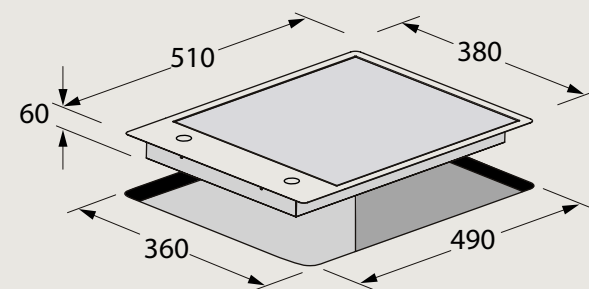

CHM 904 ID TS BK

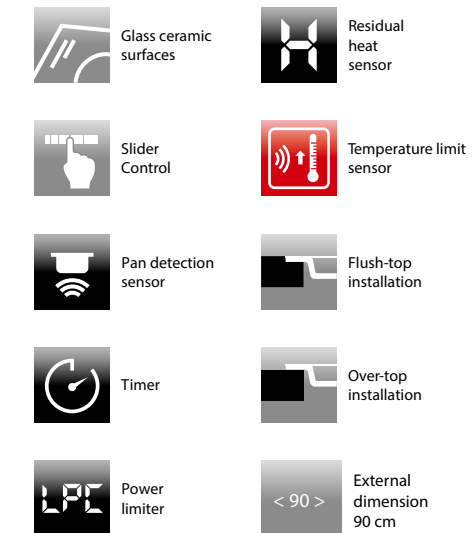
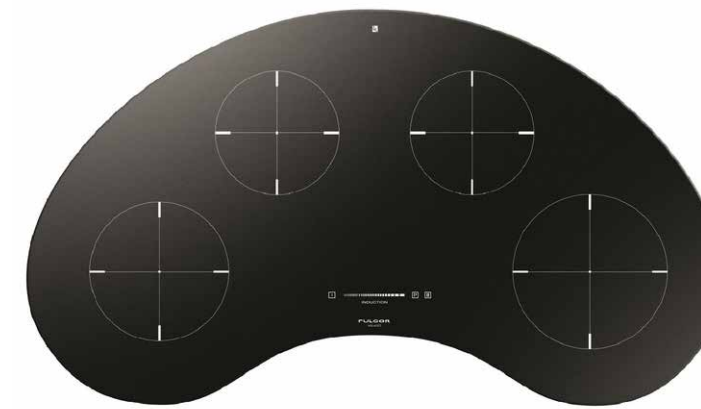

INDUCTION HOB
Glass ceramic finish with stainless steel frame

PERFORMANCE
4 hotplates
LPC limiting power consumption (removable on request)
Automatic heating
End-of-cooking timer
Pause function

FEATURES
Centralised slider touch controls

Optional flush-top installation
Optional flush and semi-flush top installation

SAFETY
Saucepan detection sensor
Safety switch (to prevent accidental use)
Residual heat indicator (H)
Automatic power off with temperature sensor

STANDARD ACCESSORIES
Scraper to clean surfaces

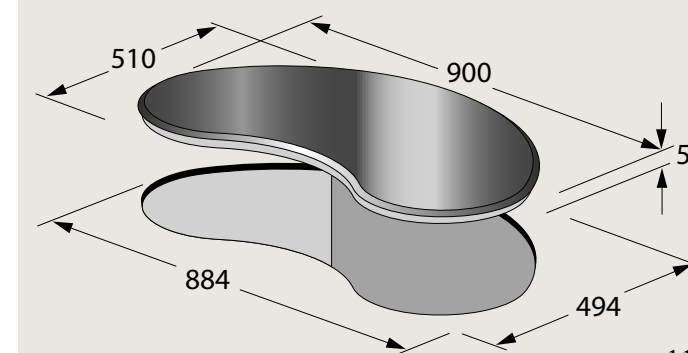

CPH 401 FR TC X



Electric Fryer Kitchen



Steel tub



Glass cover

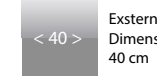

External Dimension 40 cm

ELECTRIC FRYER, SERIES 40

- ◆ Plano style (built-in flush or semi flush top)
- ◆ Removable stainless steel tub
- ◆ Steel basket for frying, with tippable handle
- ◆ Vitroceramic control insert
- ◆ Front sensor controls
- ◆ Continuous temperature regulation from 40 °C to 200 °C
- ◆ Probe for maintaining the oil temperature constant
- ◆ Protection against overheating of the oil
- ◆ Sensor for locking functions and ignition

- ◆ Connection cable with plug

ACCESSORIES

- ◆ Black tempered glass cover black with grip

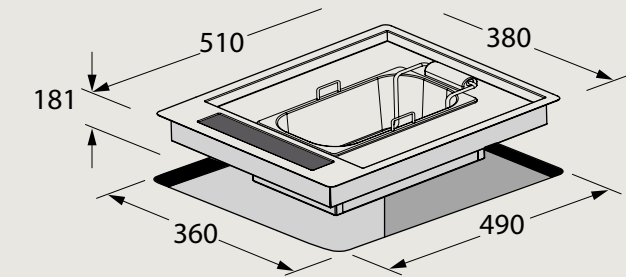

– FRYER



- OVEN

FCMO 4511 TM X

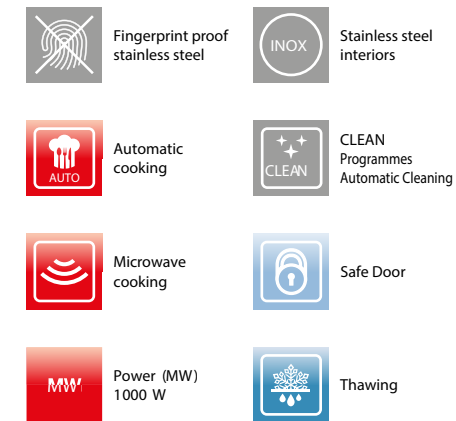

COMBINED MICROWAVE OVEN
CREACTIVE operating system
Finish: Touch proof stainless steel
PERFORMANCE
10 combined functions
Automatic cooking
Pre-selected and customizable recipes (weight, temperature, cooking time)
Microwave mode (6 levels) Combined
Microwave and fan assisted mode
Combined cooking mode
Microwave and grill mode
Defrosting by time and weight
FEATURES
Control panel with touch controls
Stainless steel interior

Internal lighting
Internal capacity 34 litres
SAFETY
Safety door
Door with safety lock
Door contact switch
Control panel safety function
Tangential cooling ventilation
STANDARD ACCESSORIES
1 round grill rack
1 stainless steel tray with grill support
1 glass turntable
Power cord with plug
COMPATIBLE WITH:
Warming drawer CWD 15 X

OPTIONAL ACCESSORIES FOR 4511 TM X

PERFORATED POT WITH LID



GASTRO BOX SET OF 6

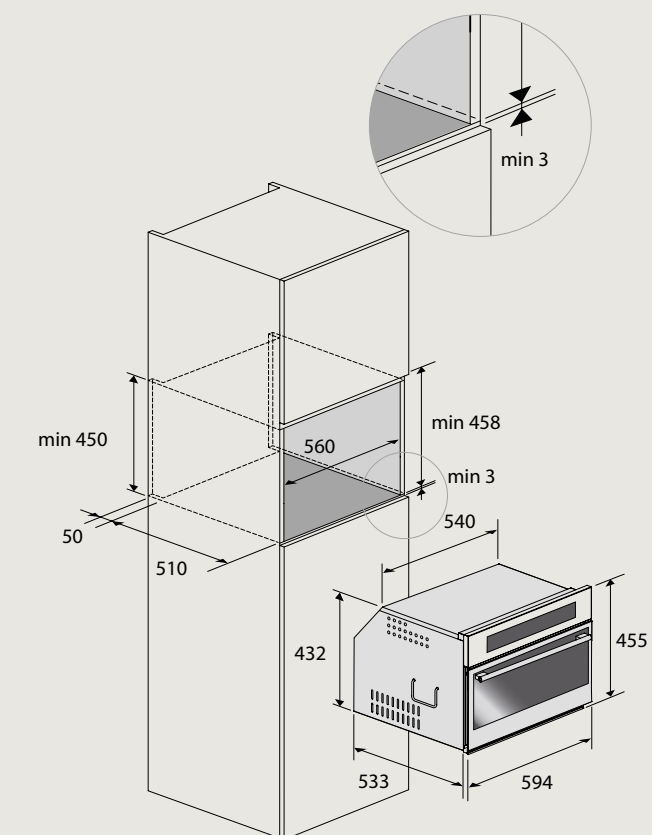

FCSO 4511 TM X

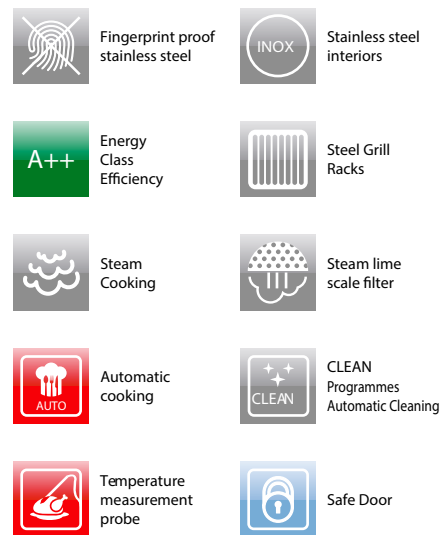

COMBINED STEAM OVEN
CREACTIVE operating system
Energy Class A++
Finish: Touch proof stainless steel

PERFORMANCE

12 functions
Automatic cooking with pre-selected and customizable recipes (weight, temperature, cooking time)
Steam system
Combined cooking functions
Steam recovery cycle
CLEAN, assisted cleaning cycle for oven interior and steam circuit

FEATURES

Control panel with touch controls
Magnetic water filter
Stainless steel interior
Internal lighting
Internal capacity 34 litres

SAFETY

Safety door
Door contact switch
Control panel safety function
Tangential cooling ventilation

STANDARD ACCESSORIES

Meat probe
1 micro-perforated pan with stainless steel cover
1 stainless steel tray
1 flat rack

Water tank

Power cord with plug

OPTIONAL ACCESSORIES

6 Gastronorm containers with cover in stainless steel, with steel rack.

COMPATIBLE WITH:

Warming drawer CWD 15 X

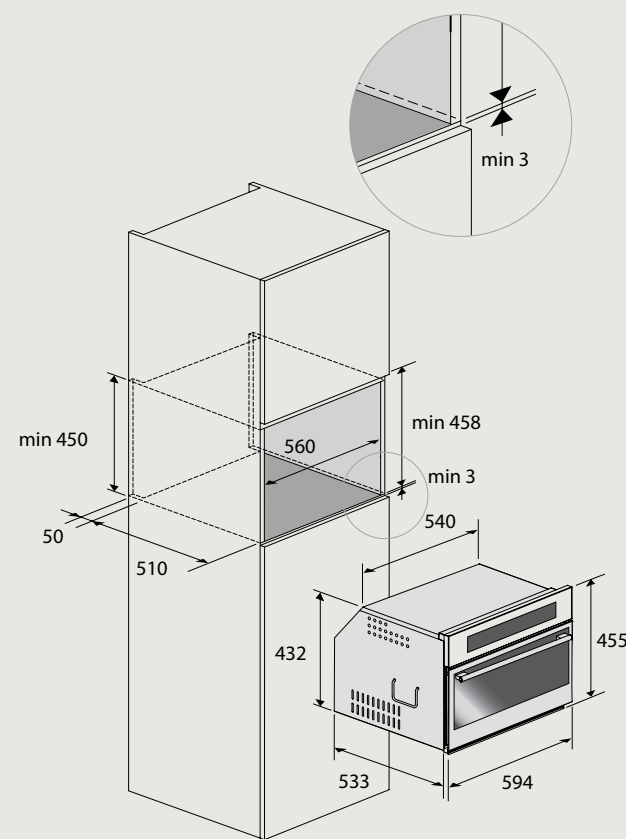

FCO 4512 TM X

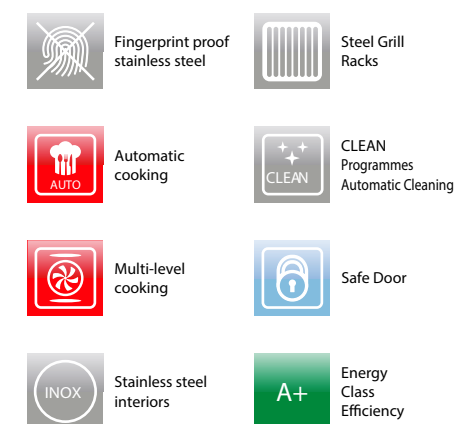

ELECTRONIC MULTIFUNCTION OVEN

CREACTIVE operating system
Energy Class A+
Finish in fingerprint resistant stainless steel

PERFORMANCE

14 cooking modes
Pre-selected and customizable recipes (weight, temperature, cooking time)
CLEAN, assisted oven cleaning cycle

BOOST, rapid pre-heating

FEATURES

Control panel with touch controls

Stainless steel interior
Internal lighting
Internal capacity 34 litres

SAFETY

Safety door
Control panel safety function
Tangential cooling ventilation

STANDARD ACCESSORIES

Removable Pizza Stone
Stainless steel tray with rack
Flat rack

Power cord with plug

COMPATIBLE WITH:

Warming drawer CWD 15 X

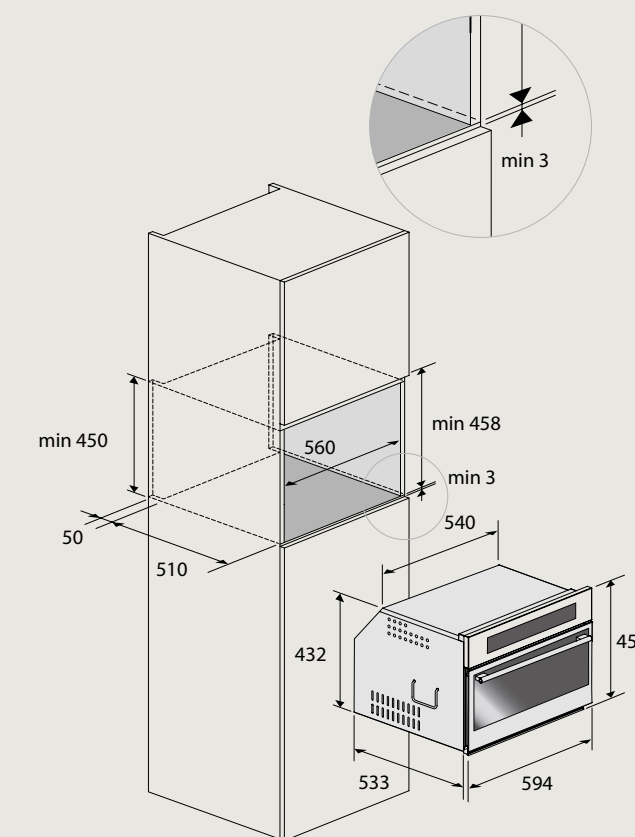

– WARMING DRAWER

CWD 15 X



Sliding
Telescopic
Rails



Slow
cooking



Fingerprint proof
stainless steel



Warming
function



Bevelled
glass



Push Opening



Leavening



Timer



Internal
Ventilation Air +

WARMING DRAWER

Front panel, height 15 cm

Push to open system

Fully removable

PERFORMANCE

Pre-heat dishes

Pre-heat coffee cups

Keep warm ready food

Defrosting

Leavening dough

Slow cooking at 70°C

FEATURES

Internal shelf surface

in black tempered glass

Internal lighting

Fan assisted

Adjustable thermostat from 40°C to 70°C

Automatic cut-off timer

Operation indicator

Safety front

STANDARD ACCESSORIES

Telescopic rails

for sliding open

Power cord with plug

COMPATIBLE WITH:

FCSO 4511 TM X

FCMO 4511 TM X



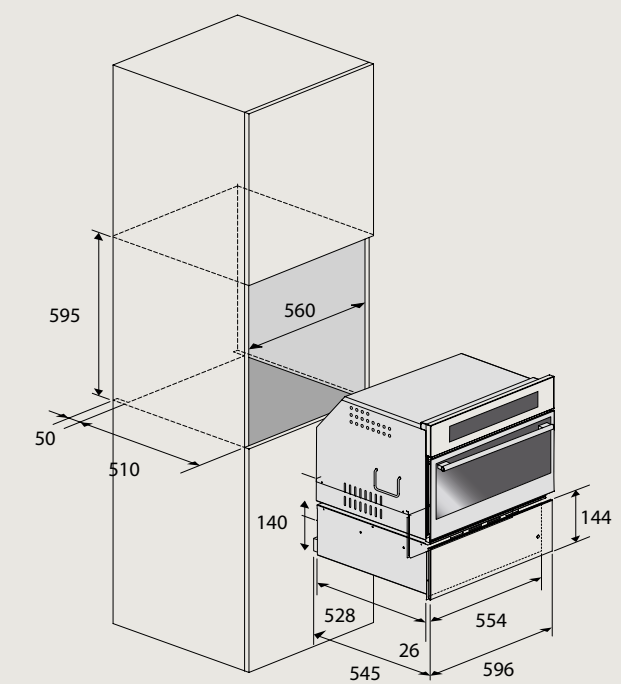



FCO 4512 TM X



– WINE CELLAR

FWC 4522 TC X



-  Digit Control
-  Internal Ventilation
-  Fingerprint proof stainless steel
-  LED lighting
-  Touch Control
-  Wine
-  22 bottle capacity
-  Telescopic Rails 3 levels



CELLAR FOR KEEPING WINE
 Instrument panel with sensor controls
 Digital display for temperature reading
CHARACTERISTICS
 Dark interior compartment
 LED lighting
 Shelves with wood slats
 Partial-extension guides
 Installable in column

Book opening door
 Alignable with other models of the Compact series
FEATURES
 Temperature regulation from 5 °C to 22 °C
 Storage capacity: 24 76- diam.bottles. 76 mm

COMBINABLE WITH:
 Food warmer drawer 15 cm

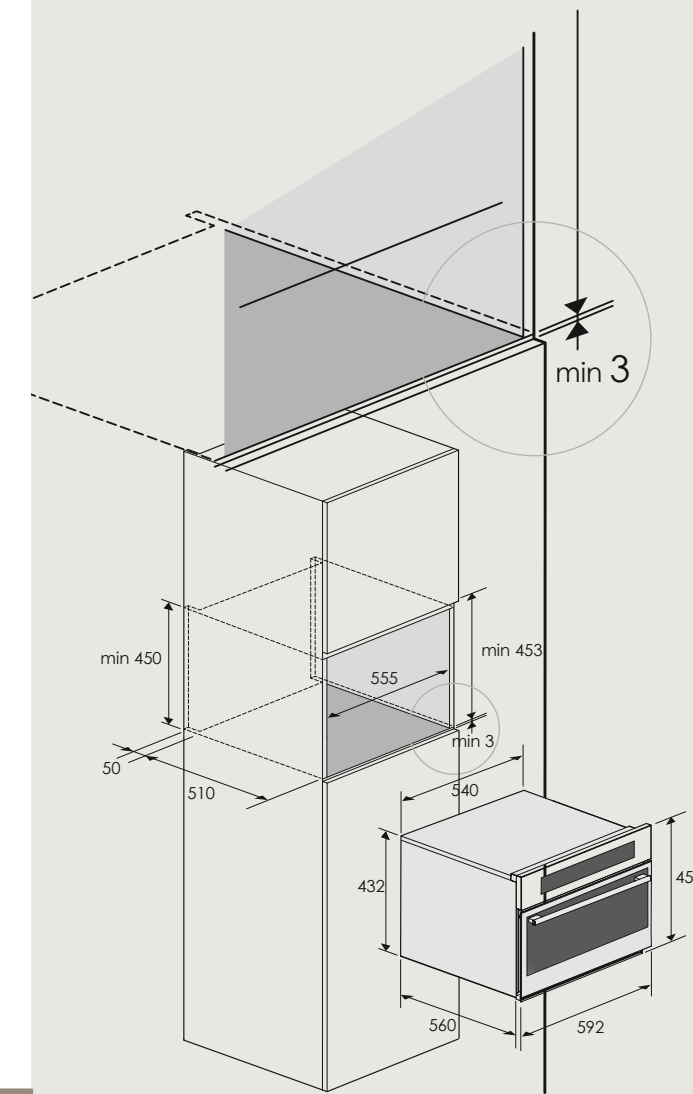

CD 15 DRAWER



OBJECT-HOLDER DRAWER
 Opening with push/pull system
 Totally removable
 Non-slip internal shelf surface, removable

COMBINABLE WITH:
 FWC 4522 TC X

ADC 150 INTERNAL CONTAINER



Equipped with wine accessories and utensils

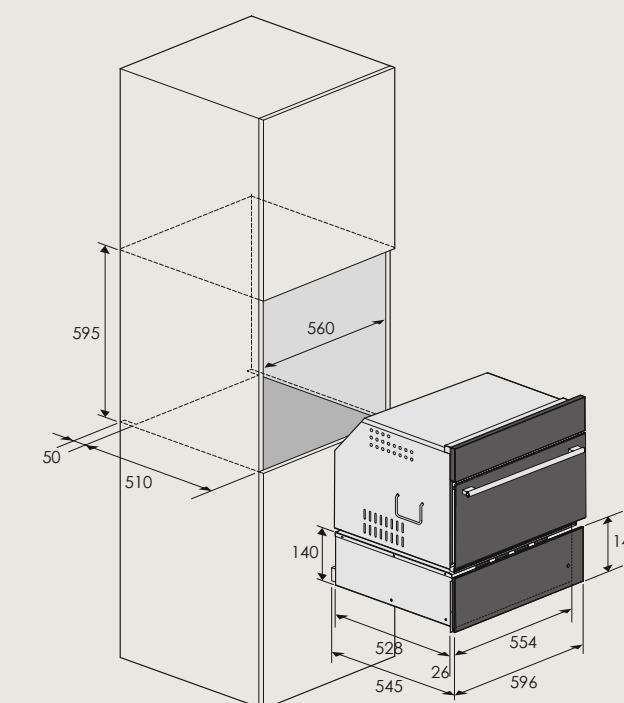



FWC 4522 TC X WINE CELLAR

WINE CELLAR DCW 62



TOTAL VOLUME
62 lt
NET WEIGHT
21 Kg
POWER SUPPLY
12/24 Vdc
100/240 Vac 50-60Hz
CONSUMPTION
0,40 kWh/24h

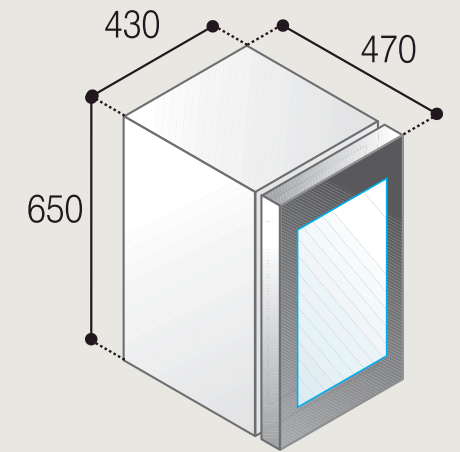

WINE CELLAR DCW 95



TOTAL VOLUME
95 lt
NET WEIGHT
26 Kg
POWER SUPPLY
12/24 Vdc
100/240 Vac 50-60Hz
CONSUMPTION
0,60 kWh/24h

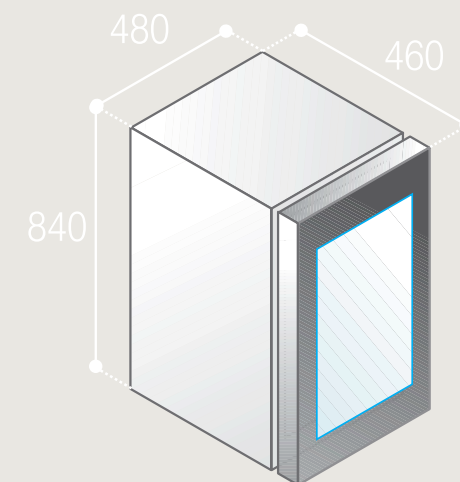
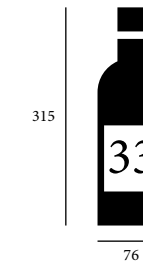

ONLY FOR CABINET

– FRIDGE and ICE MAKER



DCW 62 WINE CELLAR
C85iX FRIDGE

C85iX - FRIDGE



TOTAL VOLUME
85 lt
FREEZER COMPARTMENT
12,8 lt
NET WEIGHT
27 Kg
POWER SUPPLY AND NOMINAL CONSUMPTION
12/24 Vdc
45 W

ONLY FOR CABINET

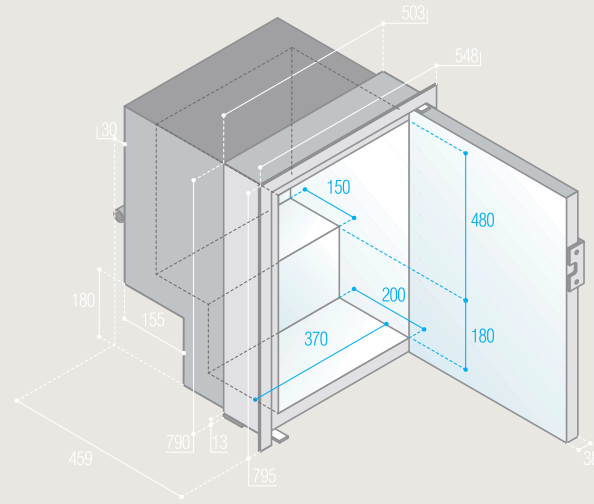

HIM HYDRO XTP - ICE MAKER

WATER CONNECTION REQUIRED



NET WEIGHT
28 Kg
POWER SUPPLY AND NOMINAL CONSUMPTION
230 Vac 50 Hz
140 W

12 Vdc
64 W

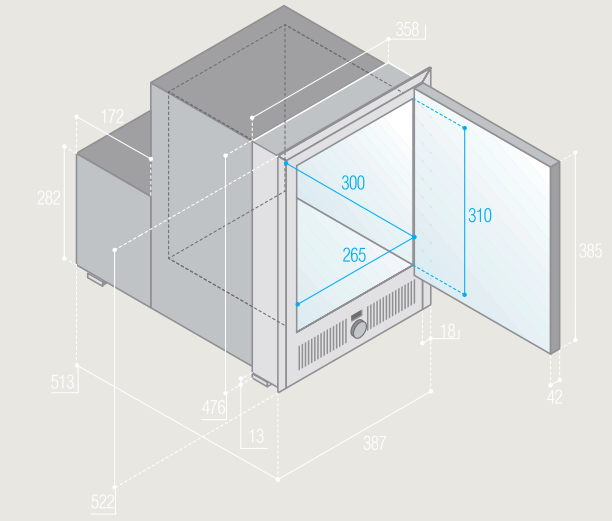

C90iX - FRIDGE



TOTAL VOLUME
90 lt
FREEZER COMPARTMENT
9,8 lt
NET WEIGHT
25 Kg
POWER SUPPLY AND NOMINAL CONSUMPTION
12/24 Vdc
45 W

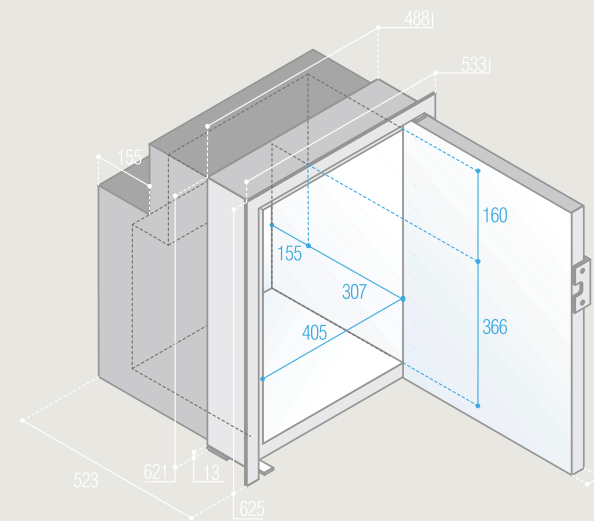

IM CLASSIC REFILL P - ICE MAKER

WATER CONNECTION NOT REQUIRED



NET WEIGHT
26 Kg
POWER SUPPLY AND NOMINAL CONSUMPTION
230 Vac 50 Hz
140 W

12 Vdc
64 W

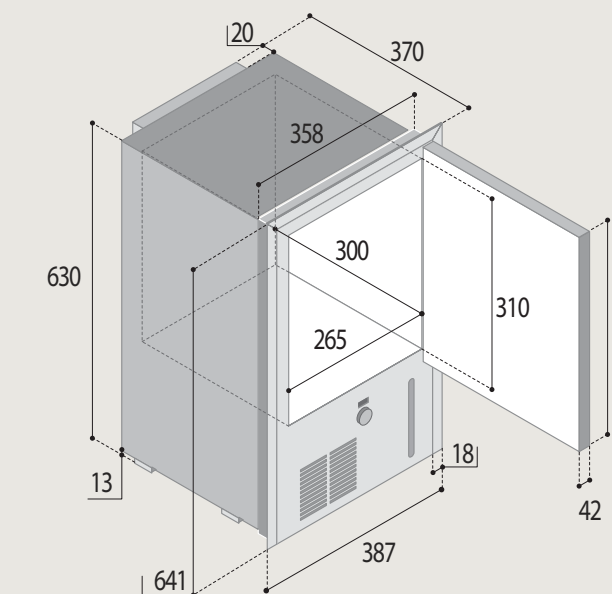

STAINLESS STEEL SINK
ANDANO 340-IF



DETAILS

Cabinet Width: 40 cm
Bowl depth: 190 mm

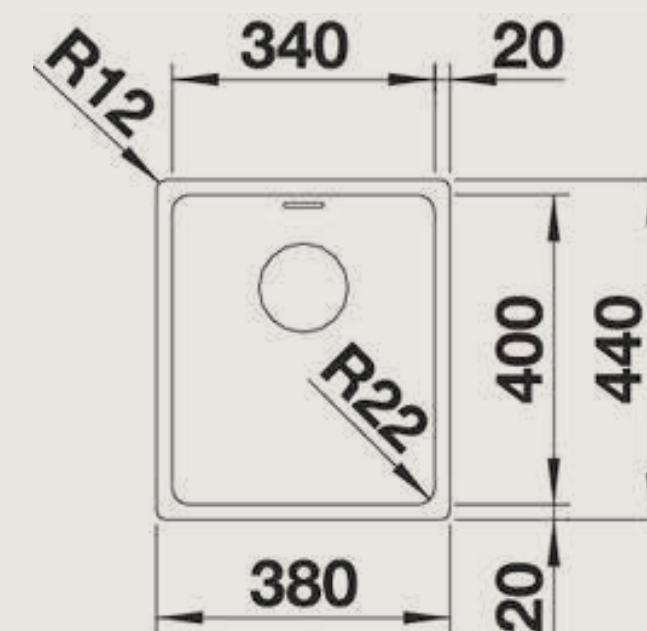

STAINLESS STEEL SINK
ANDANO 400-IF



DETAILS

Cabinet Width: 45 cm
Bowl depth: 190 mm

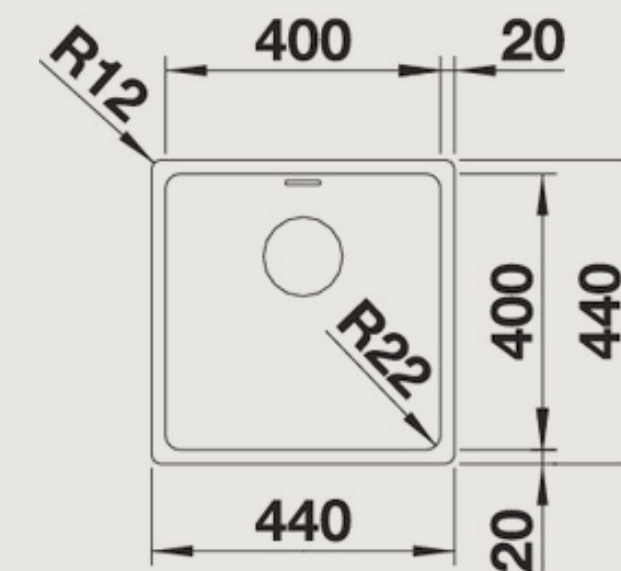

STAINLESS STEEL SINK
ANDANO 450-IF



DETAILS

Cabinet Width: 50 cm
Bowl depth: 190 mm

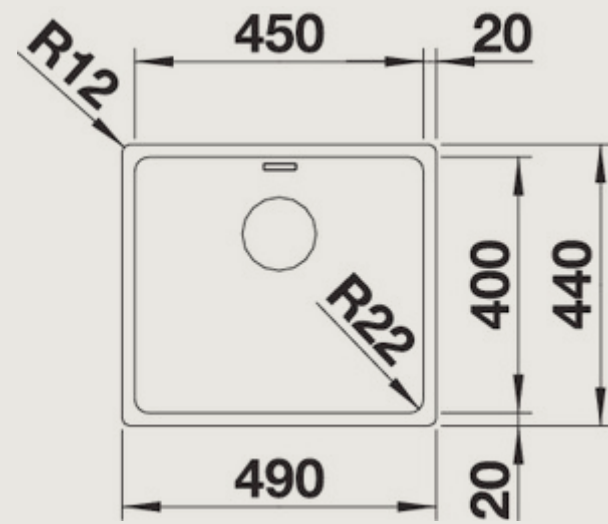

STAINLESS STEEL SINK
ANDANO 700-IF



DETAILS

Cabinet Width: 80 cm
Bowl depth: 190 mm

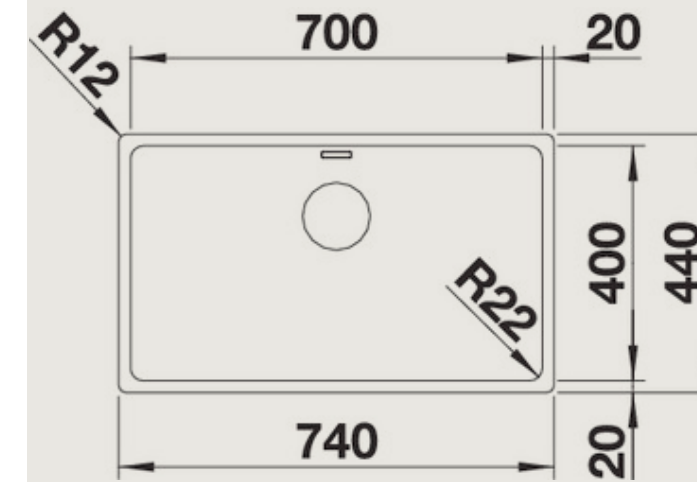

STAINLESS STEEL SINK
ANDANO 500-IF



DETAILS

Cabinet Width: 60 cm
Bowl depth: 190 mm

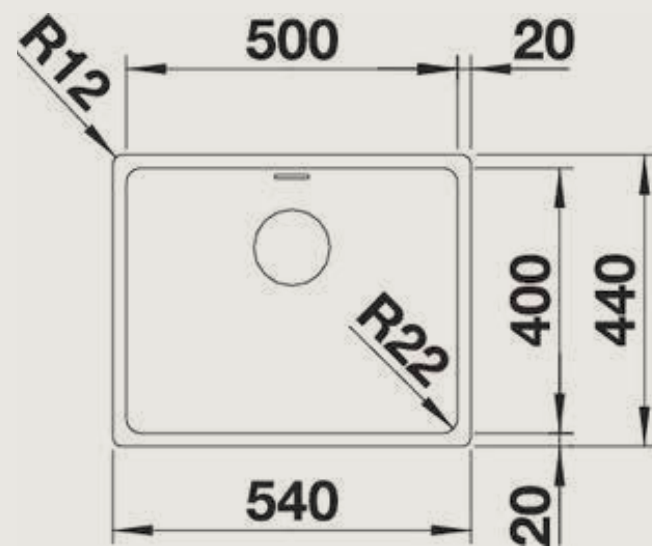

STAINLESS STEEL SINK
SM 500 / 700



DETAILS

Cabinet Width: 50 cm
Bowl depth: 222 mm



DETAILS

Cabinet Width: 70 cm
Bowl depth: 222 mm

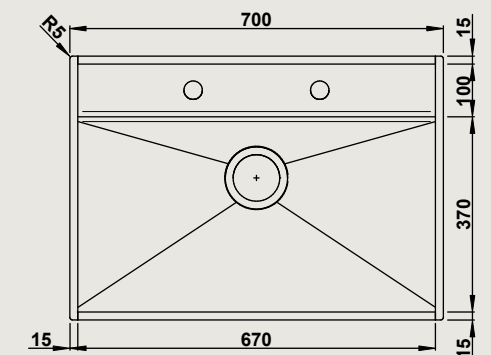
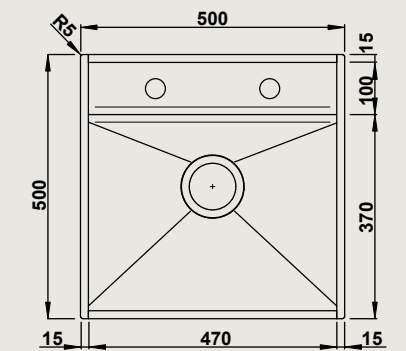

STAINLESS STEEL SINK
ATTIKA 60/A



DETAILS

Cabinet Width: 60 cm
Bowl depth: 175 mm

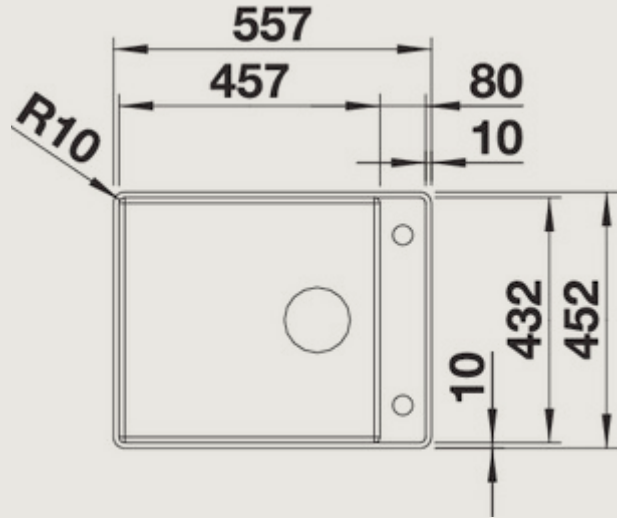

ICE BUCKET



DETAILS

Cabinet Width: 60 cm
Bowl depth: 190 mm

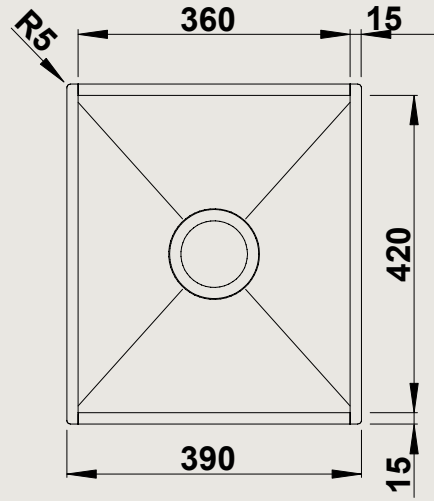

STAINLESS STEEL SINK
ATTIKA XL 60



DETAILS

Cabinet Width: 60 cm
Bowl depth: 210 mm

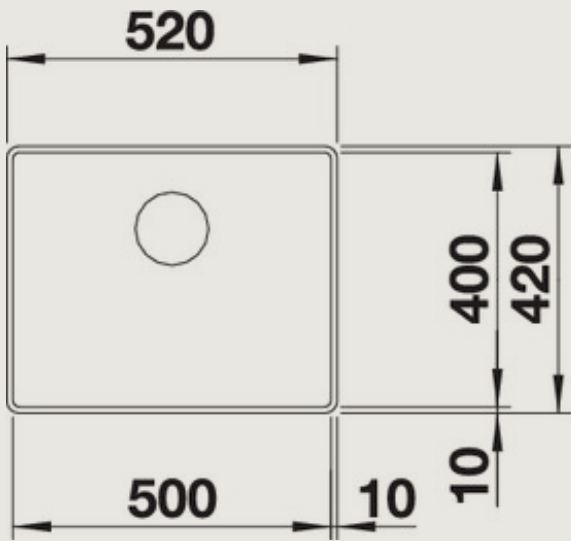

STAINLESS STEEL SINK - ATTIKA XL/60
CULINA S-MINI

RETRACTABLE MIXER TAP MT 0



SINGLE LEVER TELESCOPIC MIXER
 EAN13: 8017709108311
 Chrome finish
 Single remote lever control
 Single level valve installed separately (no more than 50cm away from the spout)

Spout swivels 360° with aerator
 Braided stainless steel connection hoses
 Minimum water pressure 0.5 bar
 Possibility of installation underneath the window

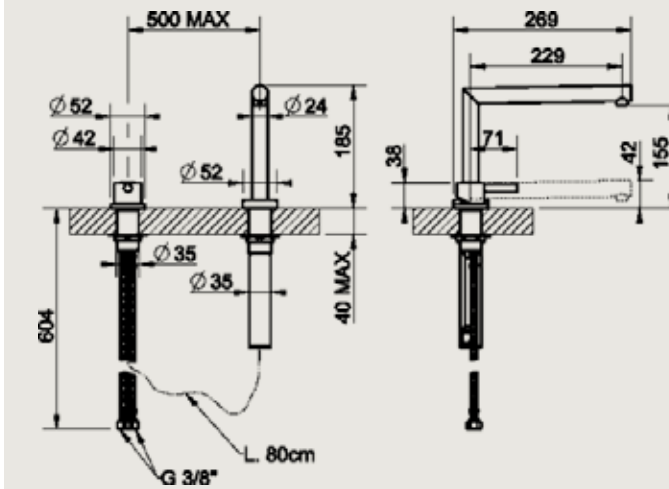

RETRACTABLE MIXER TAP ELOSCOPE



DETAILS

- ◆ Spout can be retracted and swivelled by 360°
- ◆ 2 x 35 mm Ø tap holes required for tap and operating lever
- ◆ With ceramic disk cartridge
- ◆ Flexible connector pipes, 750 mm long and 3/8" nut for particularly easy installation

- ◆ Patented jet regulator for markedly reduced scaling
- ◆ Stabilisation plate to increase the stability of the tap when fitted in stainless steel sinks
- ◆ LGA approved
- ◆ Planned for DVGW certificate

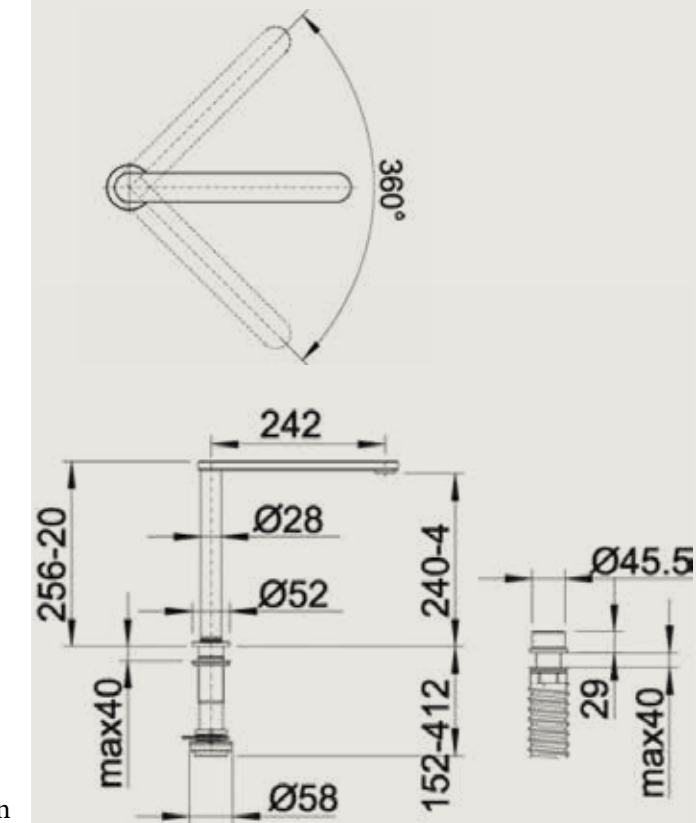

MID 9 CR



SINGLE LEVER MIXER WITH PULL OUT SPRAY
 EAN13: 8017709216948
 Chrome finish
 Single lever mixer
 Double jet spray

Flexible pull out spray nozzle with clip in option
 Aerator
 Spout swivels 360°
 Ceramic disc
 Smeg

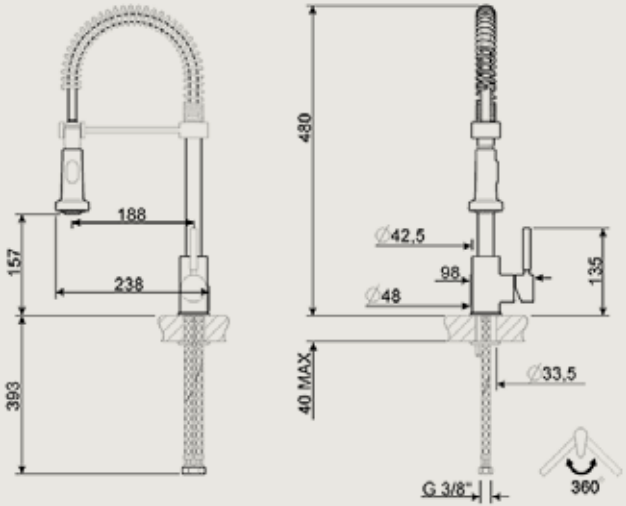

CULINA S-MINI

Available in Chrome or Inox effect



Exciting design with special visual focus
 Delicate stainless steel spring enables freedom of movement down to the bowl area
 Comfortable locking of the hose with a precise magnetic holder
 Ideal in combination with wall units
 User-friendly single-jet mousseur spray
 Spout can be swivelled by 360°

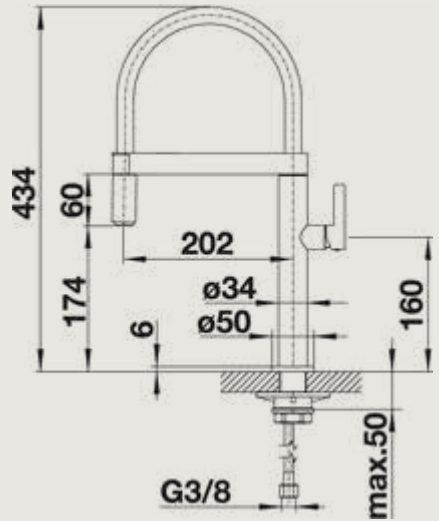

STAINLESS STEEL SINK ATTIKA 60/A
 RETRACTABLE MIXER TAP ELOSCOPE

FCM 4509 TC X

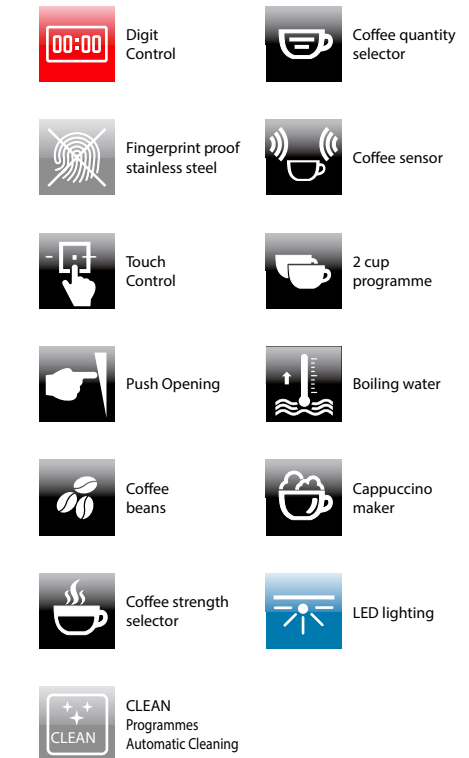

– COFFEE MACHINE

FULLY AUTOMATIC MACHINE FOR COFFEE, MILK, HOT DRINKS, STEAM

Finish in fingerprint resistant stainless steel

PERFORMANCE

Espresso / 2 x Espresso.

Coffee / 2 x Coffee.

White Coffee.

Latte macchiato.

Cappuccino.

Milk froth.

Warm milk.

Hot water.

Water heating Time 3 minutes

Automatic cleaning cycle

Stand-by (energy saving)

FEATURES

Touch control panel

Coffee bean grinder

Coffee bean container (400 g)

2.5 L water tank

Ground coffee container

Height adjustable dispenser

Steam spout

Drip tray

Telescopic rails

SAFETY

Water hardness setting

Coffee and water refill indicators

Ground coffee container to empty indicator

Cleaning indicator

Lime scale filter indicator

STANDARD ACCESSORIES

Telescopic rails

Lime scale filter

Power cord with plug

ACCESSORIES ON REQUEST

Coffee accessories wooden

container (CM DC 150)

COMPATIBLE WITH:

Fitted drawer CD15 cm

Other COMPACT 45 models

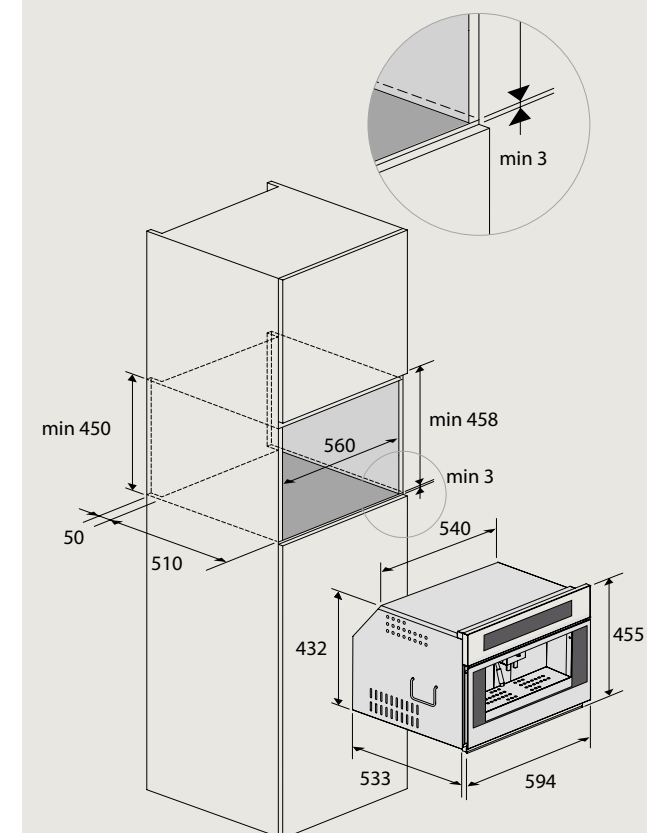

– ACCESSORIES

CUT AND CLEAN COMBO



SPECIFICATIONS:

Installed in a grill island counter top, this cleverly designed accessory lets you slice and dice on a bamboo cutting board, then sweep debris right into trash receptacle or basic trash can via a deep stainless steel trash chute.

- Bamboo cutting board
- Trash chute
- Trash can cover plate
- 304 Stainless steel construction
- Unit Dimensions – 41 x 38 cm





Is a trademark licensed to

DFN
THE OUTDOOR COMPANY

DFN srl - Italy
via D. Albertario 50 - 61032 - Fano (PU)
T. 00 39 0721 1835821

e-mail: info@dfnsrl.com

www.dfnsrl.com