

Rivolta

MADE IN ITALY

LA PELLE COME INSIEME DI EMOZIONI CHE NASCONO DALL' ESCLUSIVITÀ DI QUESTO MATERIALE E DALLA SAPIENZA DELLA LAVORAZIONE: È QUESTO IL MOOD AZIENDALE ESPRESSO NELLA CONTINUITÀ DELLE SUE COLLEZIONI IN UN' ESPRESSIONE DI ECCELLENZA INCONFONDIBILE ED UNICA IN TERMINI DI QUALITÀ E DI DETTAGLIO.

RIVOLTA ATTRIBUISCE UN VALORE DI NOBILTÀ ALLA PELLE PENSATA ED UTILIZZATA IN MODO ESCLUSIVO CON SEQUENZE DI TAGLIO, ASSEMBLAGGIO E CONFEZIONE UNICHE PER PRESTAZIONI AD ALTI LIVELLI: IL FASCINO DELLA PELLE PRENDE FORMA IN BORDI, TRAPUNTATURE, GIUNZIONI E FINITURE. RAFFINATE SENSAZIONI TATTILI MARCANO UN CONFINE NETTO TRA CONSUETO E PREZIOSO, ACCESSORI FASHION STYLE RICHIAMANO UN LINGUAGGIO DI FORTE PERSONALITÀ MAI ECCESSIVO, ANCORA UNA VOLTA L' AFFIDABILITÀ DEL CONCETTO DI QUALITÀ TOTALE CONFERMA IN RIVOLTA UN' ATTITUDINE ORIENTATA AL VALORE ASSOLUTO COME PRINCIPIO DI BASE PER LA PRODUZIONE DI ARTICOLI IN PELLE.

Leather as a series of emotions brought forth by the exclusive nature of this material and by the skilled craftsmanship: this company mood can be found in the continuity of its collections that express unmistakable and unique excellence in terms of quality and detail. Rivolta gives leather nobility, through an exclusive way of conceiving and using it with one-of-kind cutting, assembly and manufacturing for high end performance: the charm of leather is enhanced by the edging, quilting, seams and details. Refined tactile sensations mark a clear borderline between conventional and prized, fashion style accessories reflect a language with a strong but never overdone personality. Once again, the reliability of the total quality concept confirms the overall value-oriented approach of Rivolta as the underlying principle for its leather goods production.



interior collection



index

Palace_04.11
Cut_12.17
Bridge_12.21
Square_18.23
Long Island_24.29
Miami_26.27
Yossie_24.27
Fidelio_30.35
One_36.40
Forrest_42.47
Ego_48.51
XL_52.56
Coevo_58.63
Olimpia_58.59
Vesta_62.65
Carlottina_66.67
Royal_66
Isotta_68.69
Rondo_70.71
Puffo_72.73
Gala_74.75
Dado_76-77

beds collection

Capitol_80.83
XL_84.87
Nabucco_88.91
Metropolitan_92.95





DIVANO E POUF PALACE.
Palace sofa and pouf.





DIVANO PALACE.
Palace sofa.





POLTRONE PALACE.
Palace armchairs.



DIVANO PALACE.
Palace sofa.



COMPOSIZIONE CON DIVANO CUT E TAVOLINI BRIDGE.
Composition with Cut sofa and Bridge small tables.



DIVANO CUT.
Cut sofa.



LETTONE CUT E TAVOLINI BRIDGE.
Cut "lettone" and Bridge small tables.





DIVANO SQUARE E TAVOLINI BRIDGE.
Square sofa and Bridge small tables.



DIVANO SQUARE E TAVOLINI BRIDGE.
Square sofa and Bridge small tables.





DIVANO SQUARE.
Square sofa.



COMPOSIZIONE CON DIVANO LONG ISLAND, POLTRONE MIAMI E TAVOLINI YOSSIE.
Composition with Long Island sofa, Miami armchairs and Yossie small tables.



POLTRONE MIAMI E TAVOLINI YOSSIE.
Miami armchairs and Yossie small tables.





COMPOSIZIONE CON DIVANO LONG ISLAND E POUF RONDÒ.
Long Island sofa composition and Rondò pouf.



DIVANO FIDELIO.
Fidelio sofa.





DIVANO FIDELIO E POUF RONDÒ.
Fidelio sofa and Rondò pouf.



DIVANO FIDELIO.
Fidelio sofa.



DIVANO ONE.
One sofa.





COMPOSIZIONE DIVANO ONE.
One sofa composition.



POLTRONA ONE.
One armchair.



DIVANO FORREST.
Forrest sofa.





DIVANO FORREST E POLTRONE EGO.
Forrest sofa and Ego armchairs.



POLTRONE FORREST.
Forrest armchairs.





POLTRONA EGO.
Ego armchair.





POLTRONA EGO.
Ego armchair.



DIVANO XL.
XL sofa.





COMPOSIZIONE DIVANO XL.
XL sofa composition.





DIVANO XL.
XL sofa.



SEDIA OLIMPIA E TAVOLO COEVO.
Olimpia chair and Coevo table.





SEDIA OLIMPIA CON BRACCIOLI.
Olimpia chair with arms.





SEDIA VESTA E TAVOLO COEVO.
Vesta chair and Coevo table.





SEDIA VESTA.
Vesta chair.



TAVOLO ROYAL E SEDIA CARLOTTINA.
Royal table and Carlottina chair.





POLTRONA ISOTTA.
Isotta armchair.





POUF RONDÒ.
Rondò pouf.



POUF PUFFO.
Puffo pouf.



TAVOLINO/POUF GALA.
Gala small table/pouf.



TAVOLINO/POUF DADO.
Dado small table/pouf.



LA CAMERA DA LETTO È IL NOSTRO LUOGO SICURO, IL LUOGO DEL RIPOSO DEL RELAX E DEI SOGNI. TUTTO DEVE ESSERE PENSATO E STUDIATO PER RILASSARE CORPO E MENTE. UN RIFUGIO DAL MONDO CAOTICO, DALLO STRESS, DAL RUMORE. IL LETTO PROTAGONISTA DEL RIPOSO E DEL DORMIRE È NIDO INDISCUSSO DOVE RIFUGIARSI, COCCOLARSI, SCALDARSI.

FORTINO DEI NOSTRI SOGNI, IL LETTO CI ABBRACCIA, CI ACCAREZZA, CI EMOZIONA E PER QUESTO IL SUO DISEGNO, LA SUA IMMAGINE IL SUO STILE DEVE ACCOMPAGNARE CIÒ CHE DESIDERIAMO, CIÒ CHE VIVIAMO CIÒ CHE NOI SIAMO.

PRODOTTO ED EMOZIONE DEVONO DIALOGARE IN ARMONIOSA SINTONIA SPOSANDO UN UNICO LINGUAGGIO, QUELLO DELLA SENSIBILITÀ. SENSIBILITÀ ALLA QUALITÀ ALLA BELLEZZA ALL'ELEGANZA; SENSIBILITÀ ALLA LETTURA DELL'INTIMITÀ DEL SEGRETO, DELL'ESCLUSIVITÀ.

The bedroom is our haven, the place where we can rest, relax and dream. Everything needs to be conceived and designed to relax mind and body - a refuge from the world of chaos, from stress, from noise.

The bed is the quintessential place of repose and sleep, it is the sanctuary where we can hide, pamper and warm ourselves.

Stronghold of our dreams, the bed embraces us, it caresses us, it conveys feelings and therefore its design, its image and style must go hand in hand with our wishes, lifestyle and feelings - product and emotion must communicate in perfect harmony, using a single language - sensibility.

Sensibility towards quality, beauty and elegance; sensibility towards the interpretation of intimacy, secrecy and exclusiveness.

beds collection





LA SCANSIONE VERTICALE DELLE CUCITURE INVIGORISCE L'ASPETTO RIGOROSO E RAZIONALE DEL LETTO, IN CUI TESTATA E PEDIERA ABBRACCIANO IL MATERASSO DELIMITANDONE I CONFINI PER PROTEGGERE L'ISOLA DELL'INTIMITÀ. LA LINEA RIGIDA DEL DESIGN VIENE ADDOLCITA DALLA MORBIDEZZA DELL'IMBOTTITURA E DAL RIVESTIMENTO IN PELLE O TESSUTO.

The vertical run of the stitching underlines the sleek, rational look of the bed, where headboard and footboard embrace the mattress marking the boundaries to protect this island of intimacy.

The inflexible line of the design is offset by the soft padding and by the leather or fabric cover.

capitol

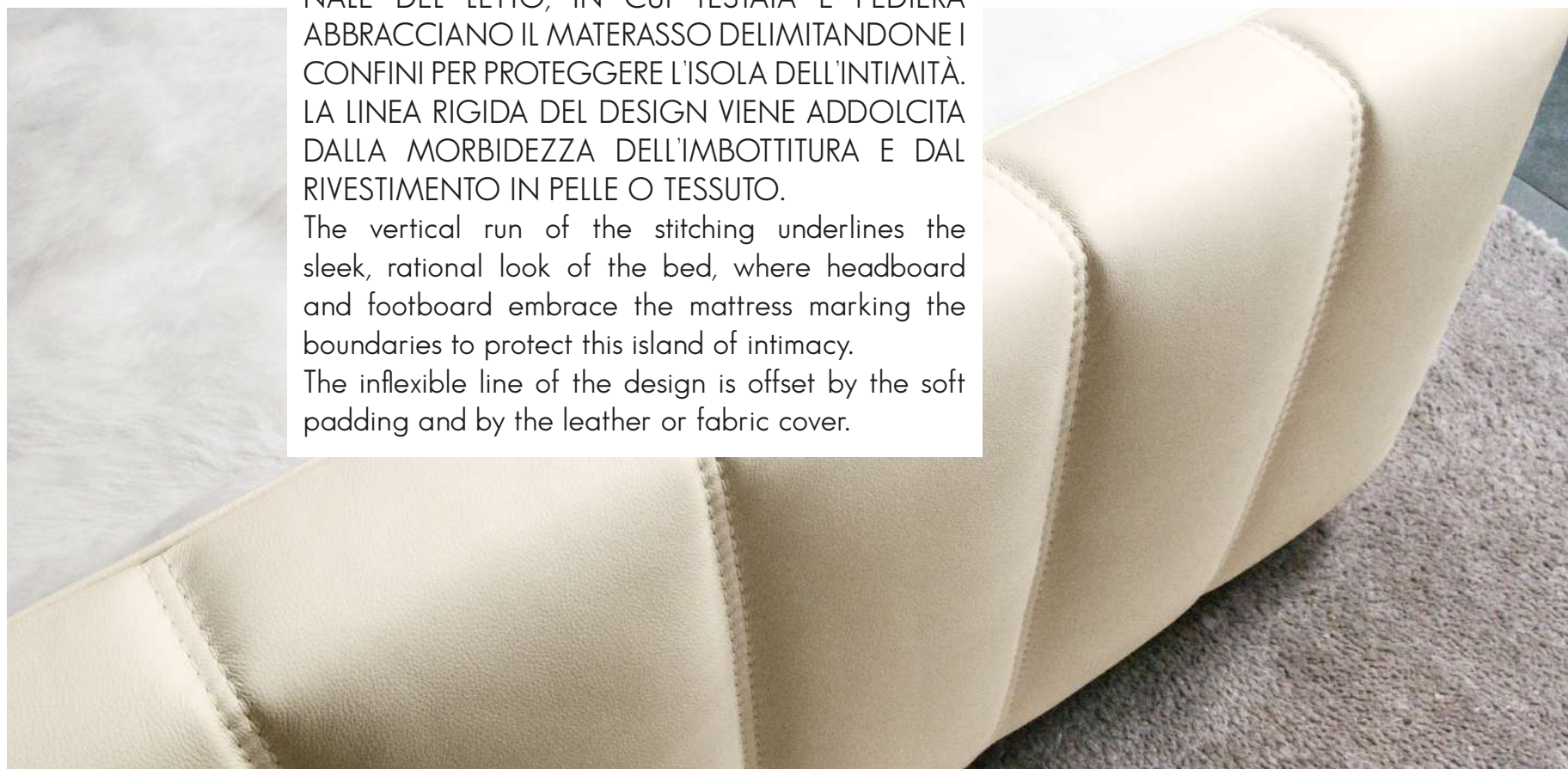



LETTO CAPITOL E POUF DADO.
Capitol bed and Dado pouf.



ESEMPIO DI EQUILIBRIO PERFETTO TRA PULIZIA FORMALE E GUSTO ATTUALE.

IL GIROLETTO SEMPLICE ED ESSENZIALE SPOSA UNA TESTATA SAGOMATA E DAL FORTE SPESSORE. ELEMENTI VINCENTI IN UN MODELLO CHE, OLTRE LA LINEA MODERNA OFFRONO UN'ESTETICA RAFFINATA.

I PIEDINI BASSI CROMATI ESALTANO E RAFFORZANO L'IMMAGINE PULITA E RIGIDA DEL DESIGN.

Example of perfect balance between formally clean lines and contemporary taste.

The simple, essential frame is combined with a shaped, extra thick headboard, winning elements in a model that, along with the modern line offer refined aesthetics.

The low chromed feet highlight and strengthen the clean, rigid appearance of the design.

XL





LETTO XL E YOSSIE TAVOLINO.
XL bed and Yossie small table.



IL DISEGNO PRECISO CHE INTERPRETA CON SOBRIETÀ L'IDEA DEL LUSSO, VALORIZZA LA QUALITÀ E LA NATURALEZZA DELLA PELLE, RICONOSCIBILE ANCHE NEI DETTAGLI. UN LETTO PENSATO CON TUTTI I REQUISITI PER DIVENTARE UN PEZZO CHE RESISTE NEL TEMPO IN GRADO DI ARREDARE OGNI TIPO DI STANZA. The clean design, a sober interpretation of the idea of luxury enhances the quality and the naturalness of leather, also recognisable in the details. A bed conceived with all the requisites to become a long-lasting piece that can furnish any kind of room.

nabucco

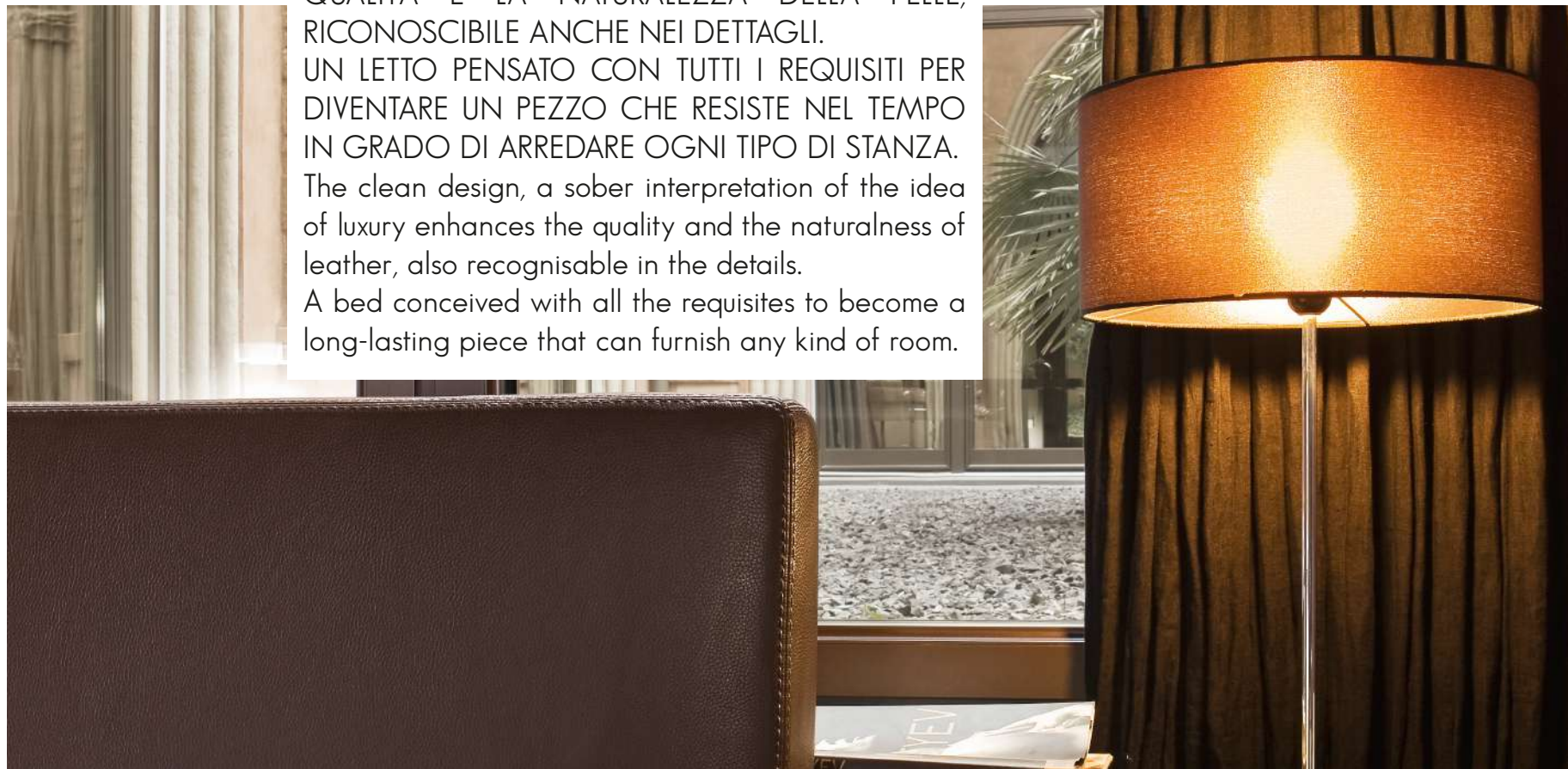



LETTO NABUCCO.
Nabucco bed.



LA SEMPLICITÀ NON È SINONIMO DI POVERTÀ, ANZI DIVENTA PECULIARITÀ DI PULIZIA FORMALE DI ELEGANZA. UN GIROLETTO A MISURA DI MATERASSO CHE NON INGOMBRI E CHE LASCI RESPIRO ALLA STANZA, UNA TESTATA LISCIA LEGGERMENTE MORBIDA AGLI SPIGOLI PER FAR VIVERE PIENAMENTE LA BELLEZZA DELLA PELLE.

Simplicity is not another word for poverty, on the contrary it becomes a distinctive quality of formal cleanliness, of elegance. A frame to fit the mattress that does not clutter and that leaves room to breathe, a sleek headboard, with slightly softened edges to make the most of the beauty of leather.

metropolitan

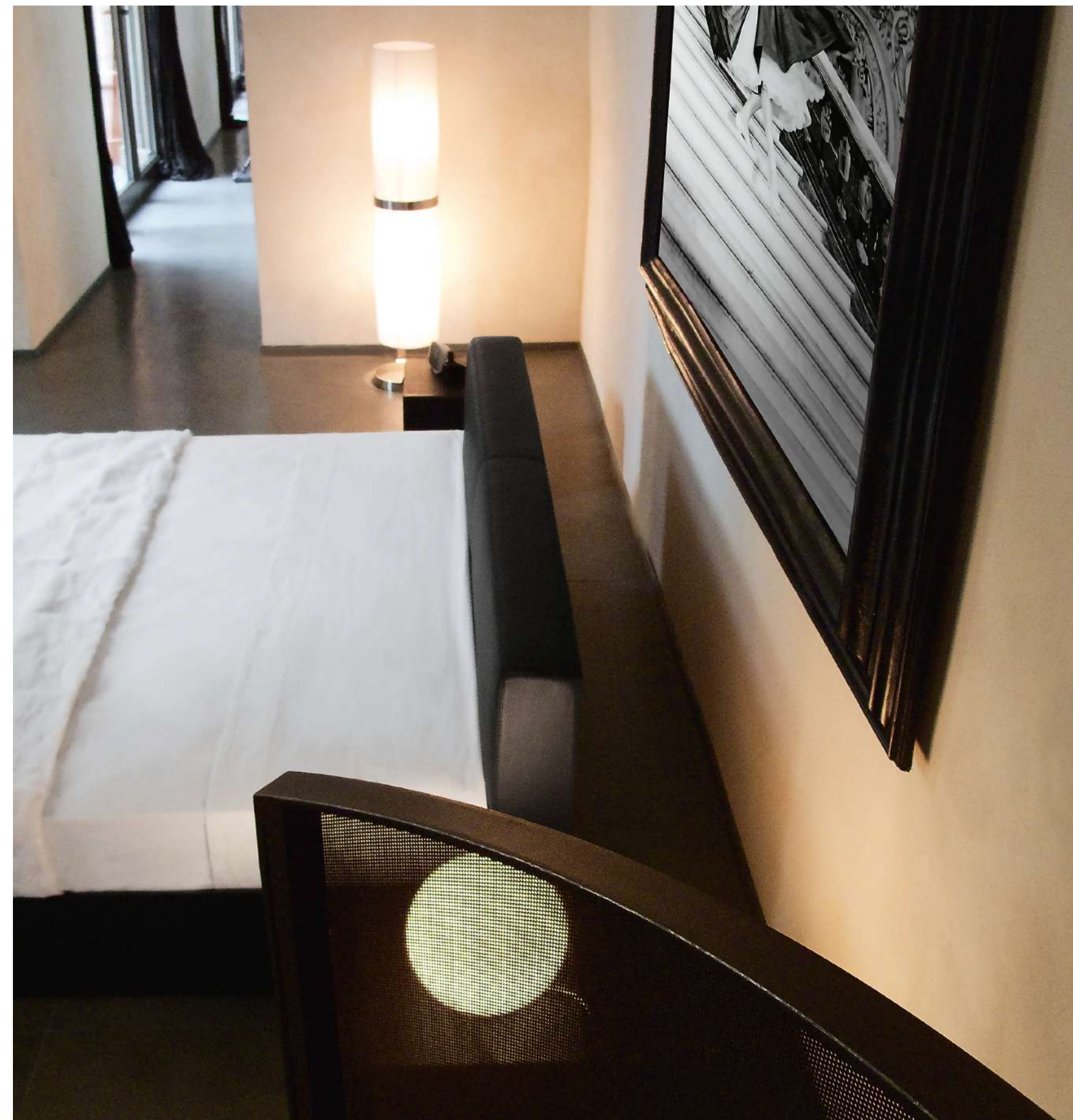
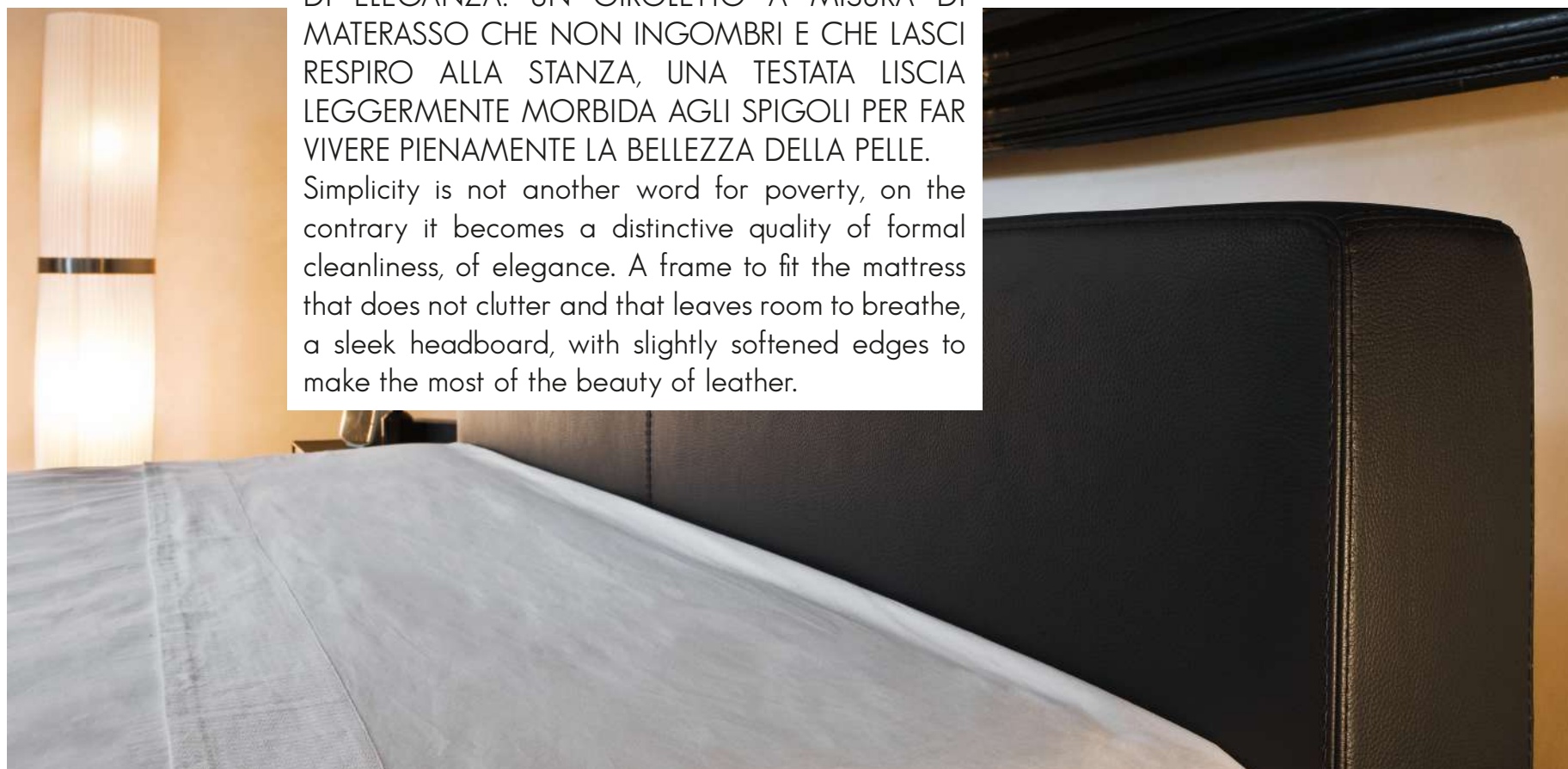



LETTO METROPOLITAN E COMODINI LUXURY.
Metropolitan bed and Luxury bedside tables.

Schede Tecniche

Technical Descriptions



PALACE design Daniele Lo Scalzo Moscheri

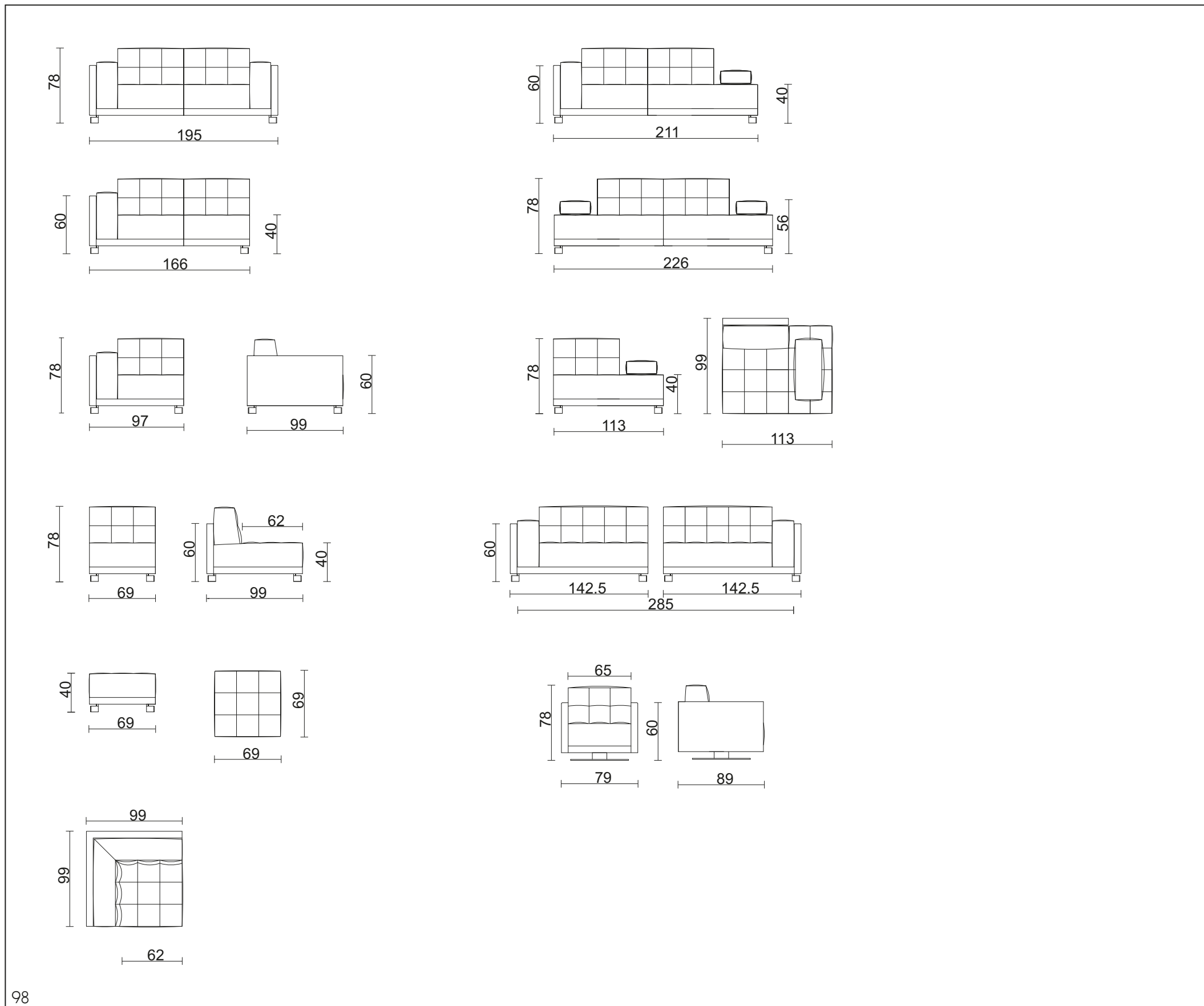

PALACE design Daniele Lo Scalzo Moscheri

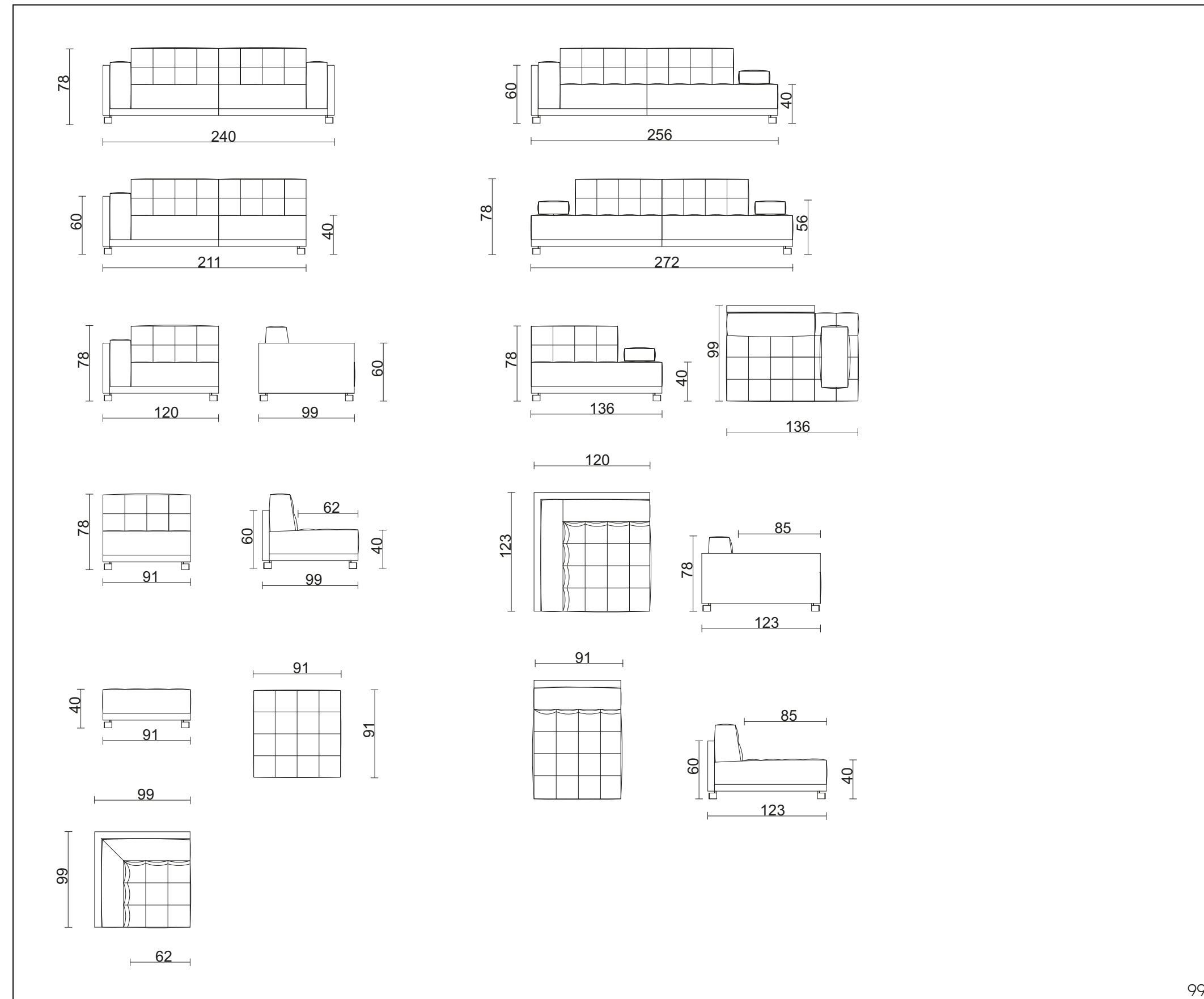



CUT design Daniele Lo Scalzo Moscheri

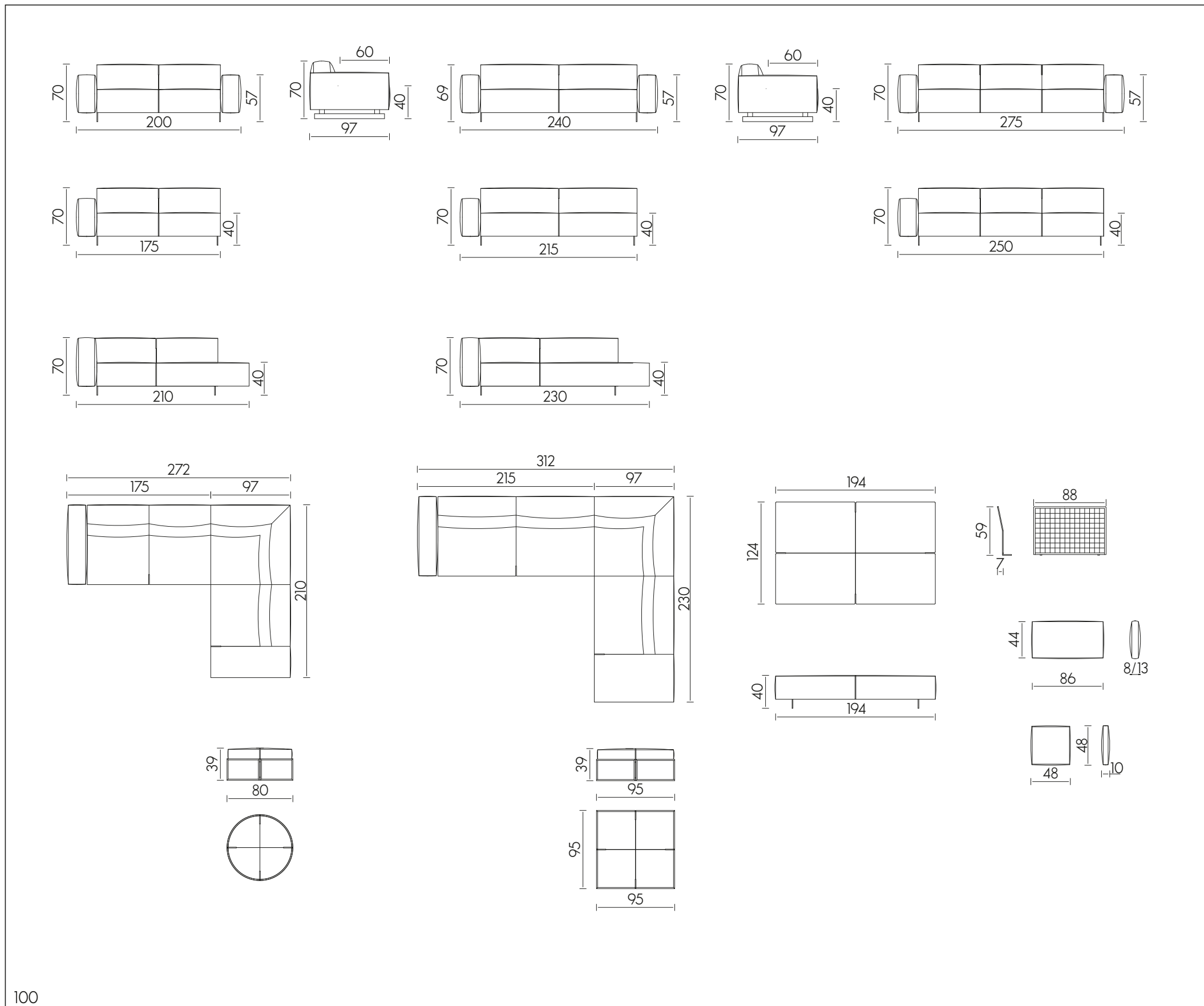

BRIDGE design Daniele Lo Scalzo Moscheri

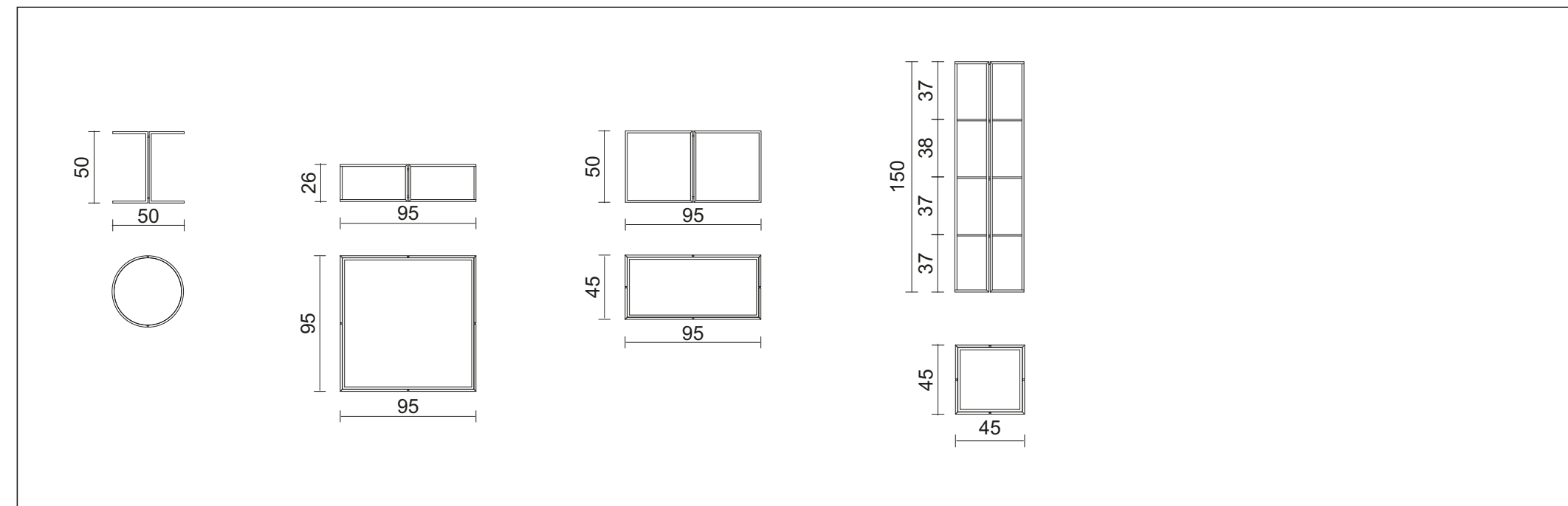



SQUARE

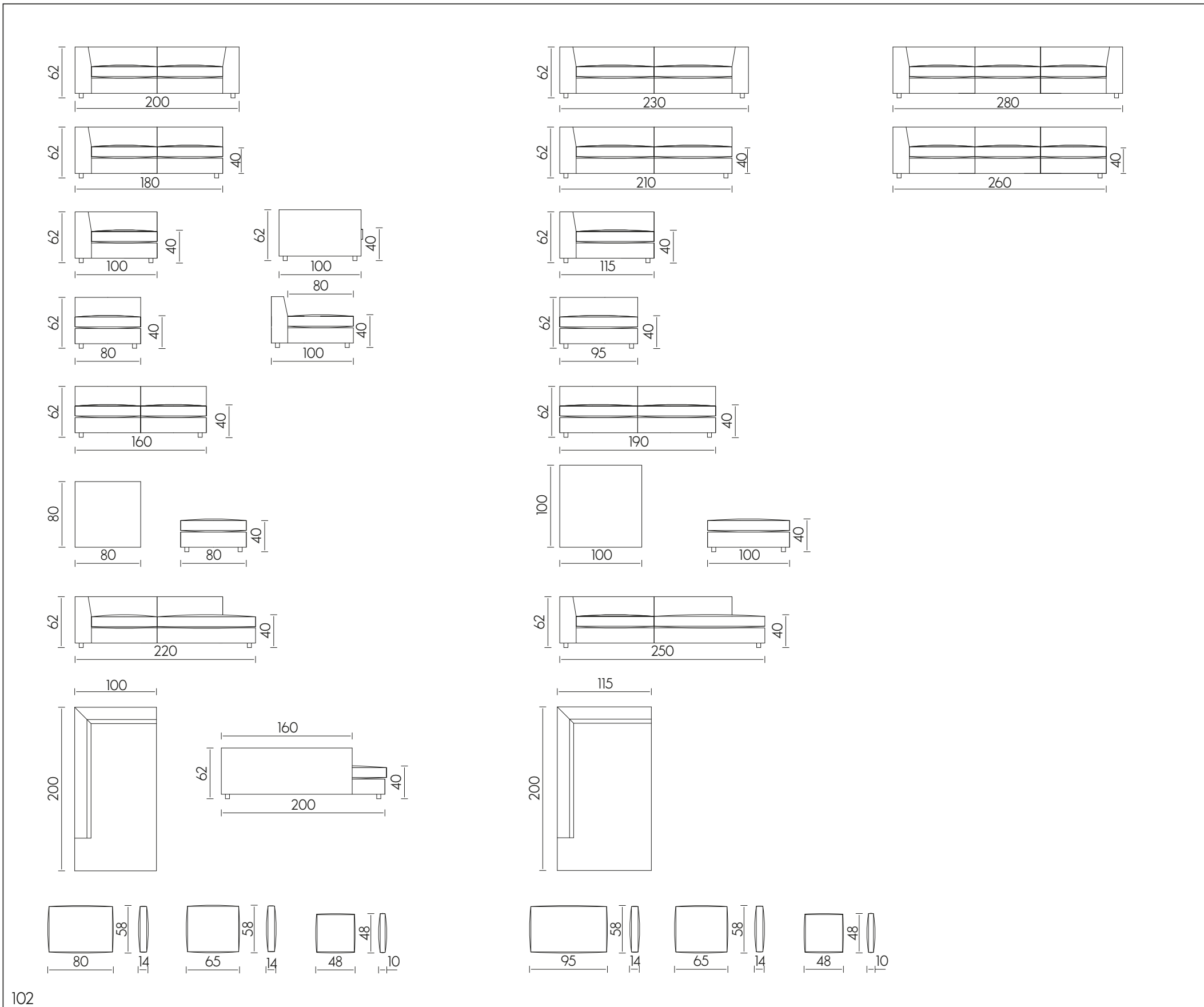

SQUARE Composizioni/Compositions

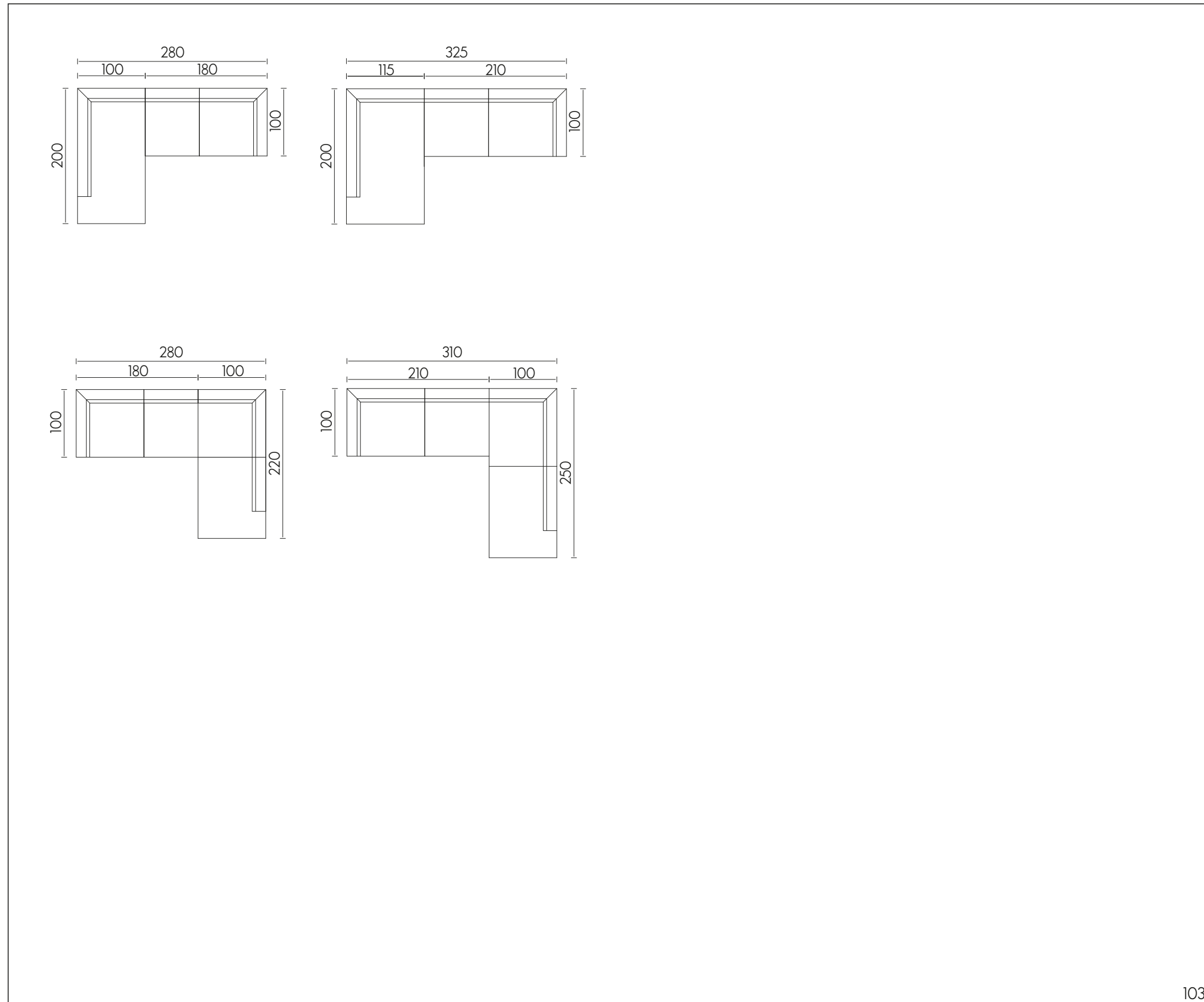



LONG ISLAND

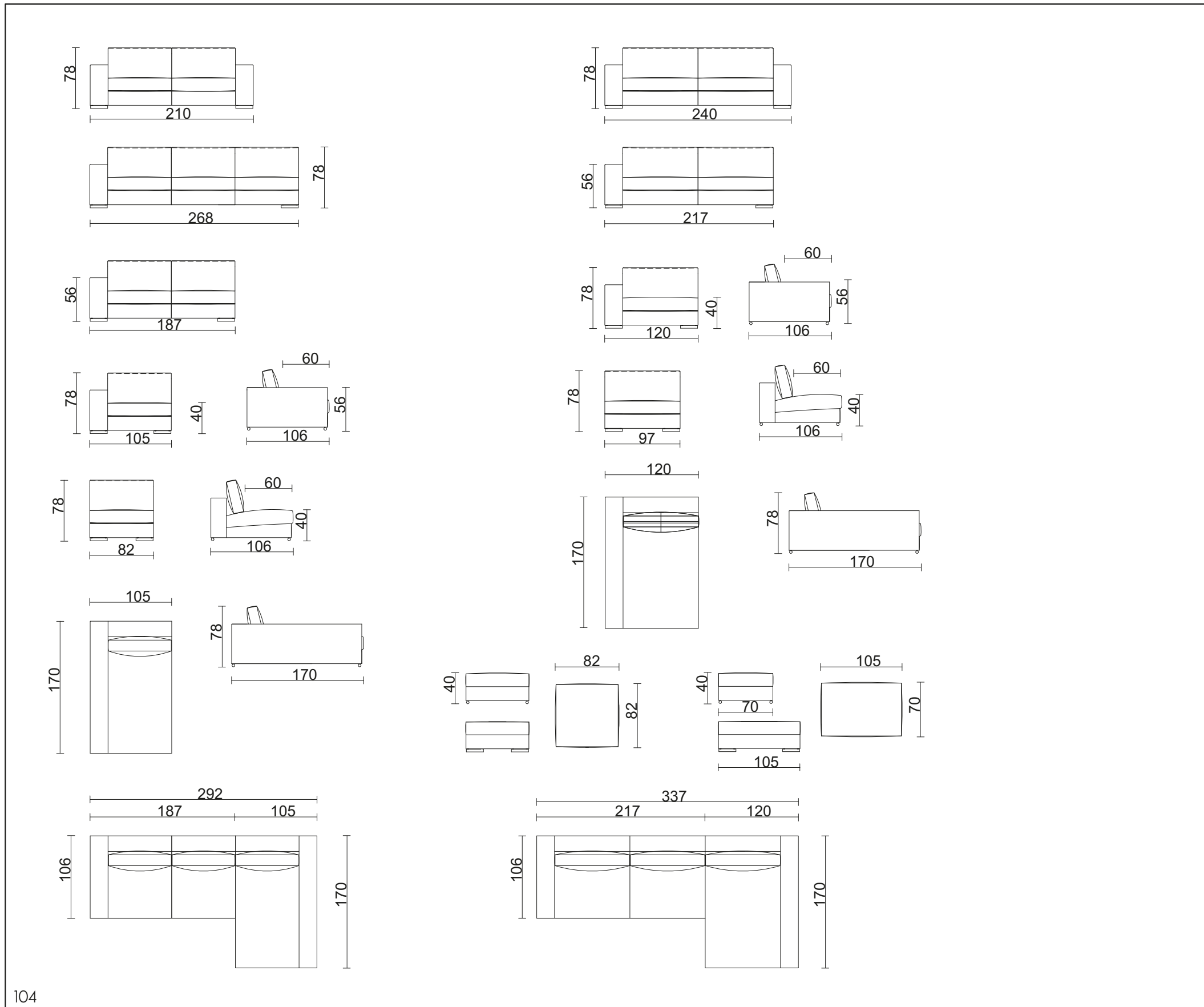

MIAMI design Daniele Lo Scalzo Moscheri

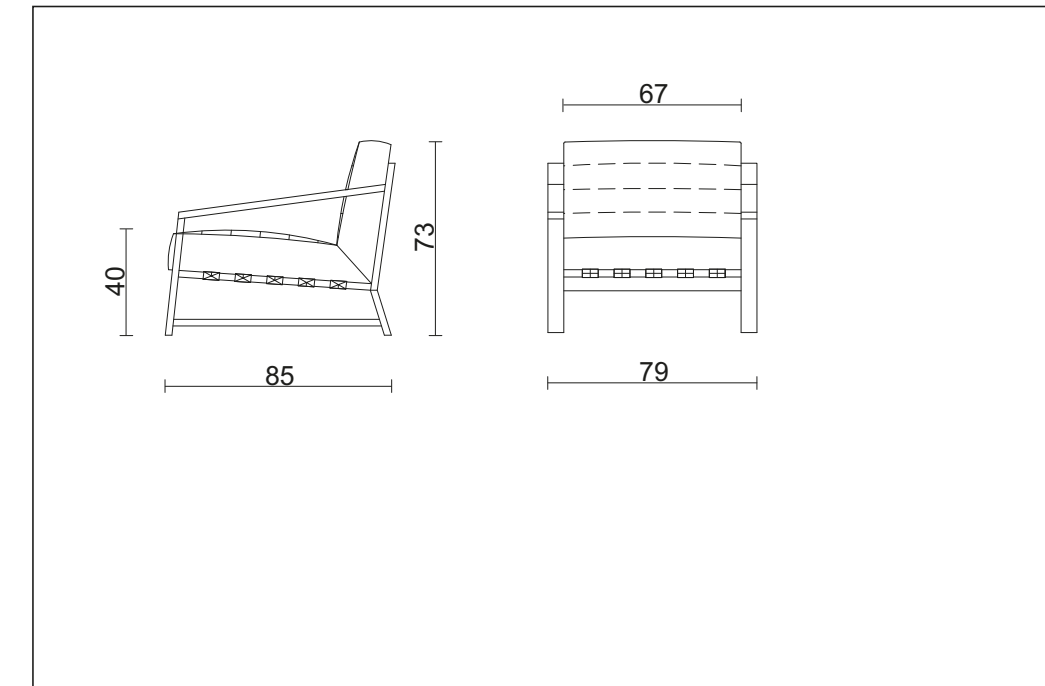

YOSSIE design Daniele Lo Scalzo Moscheri

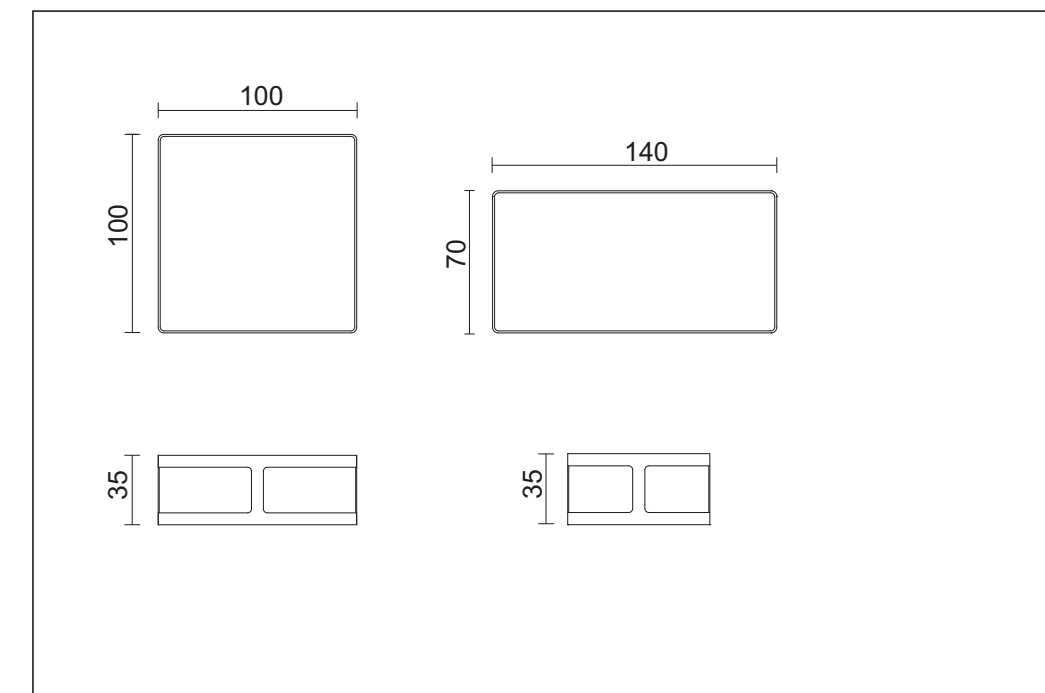



FIDELIO design Giuseppe Viganò

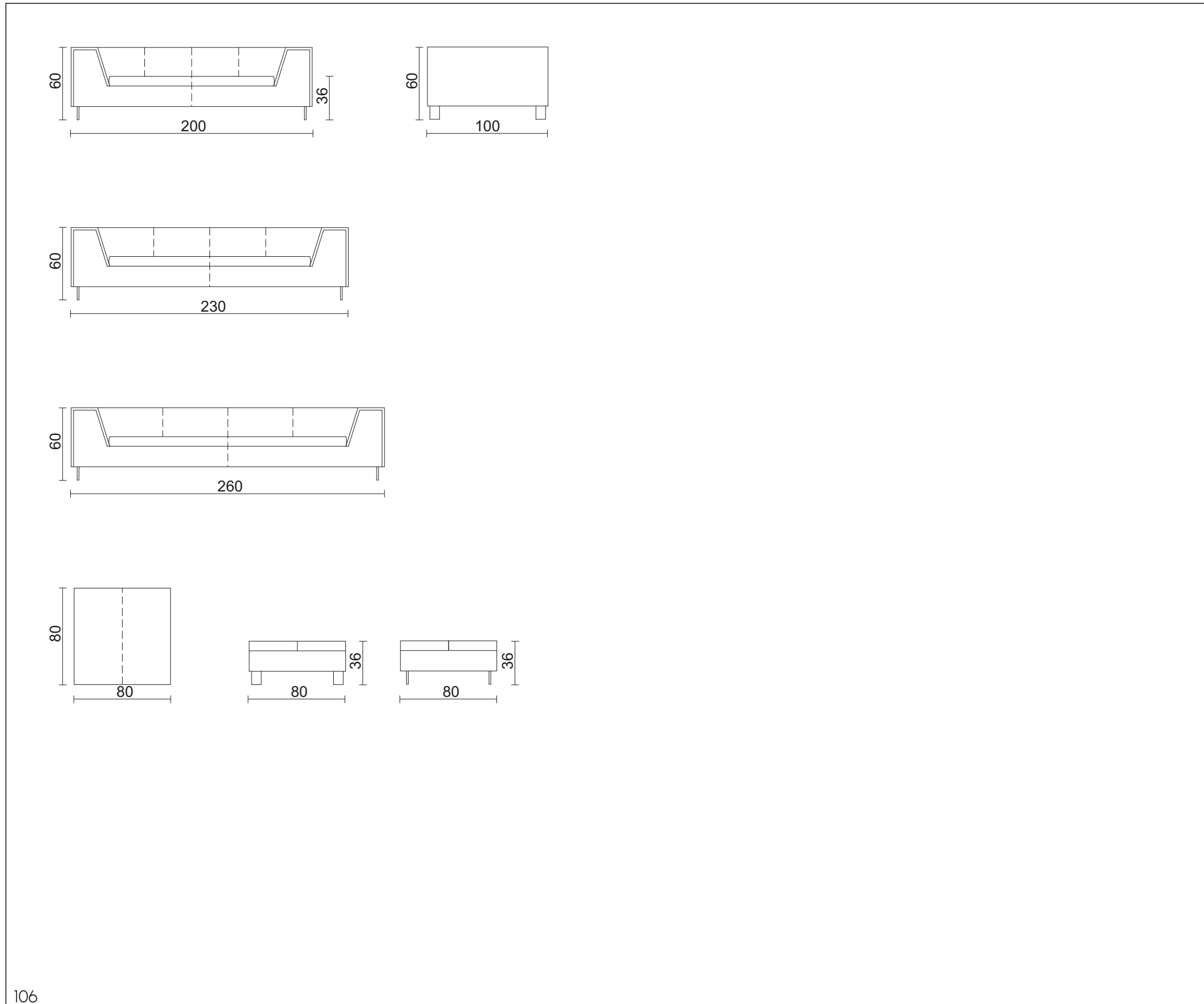

ONE design Giuseppe Viganò

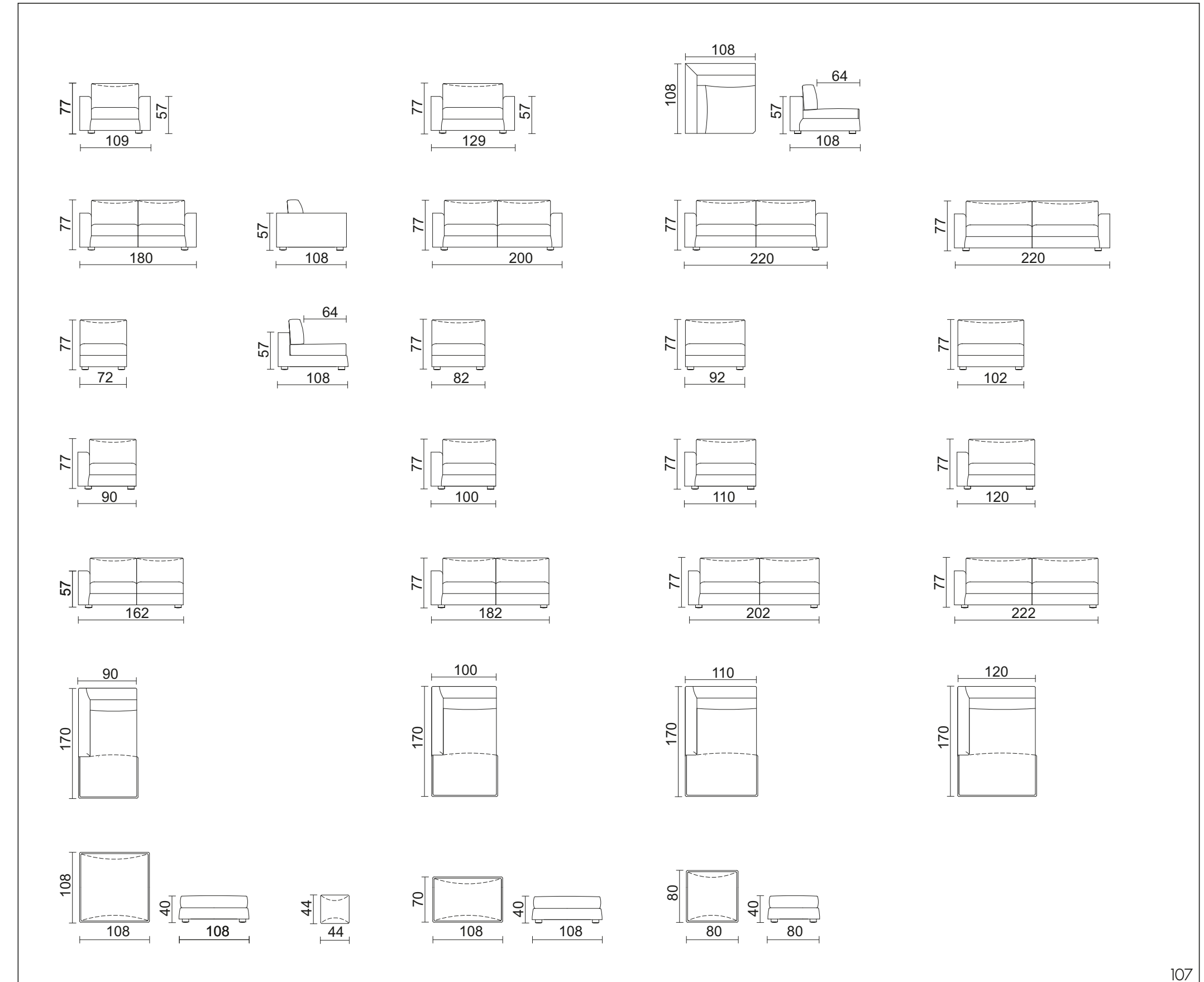



FORREST design Giuseppe Viganò

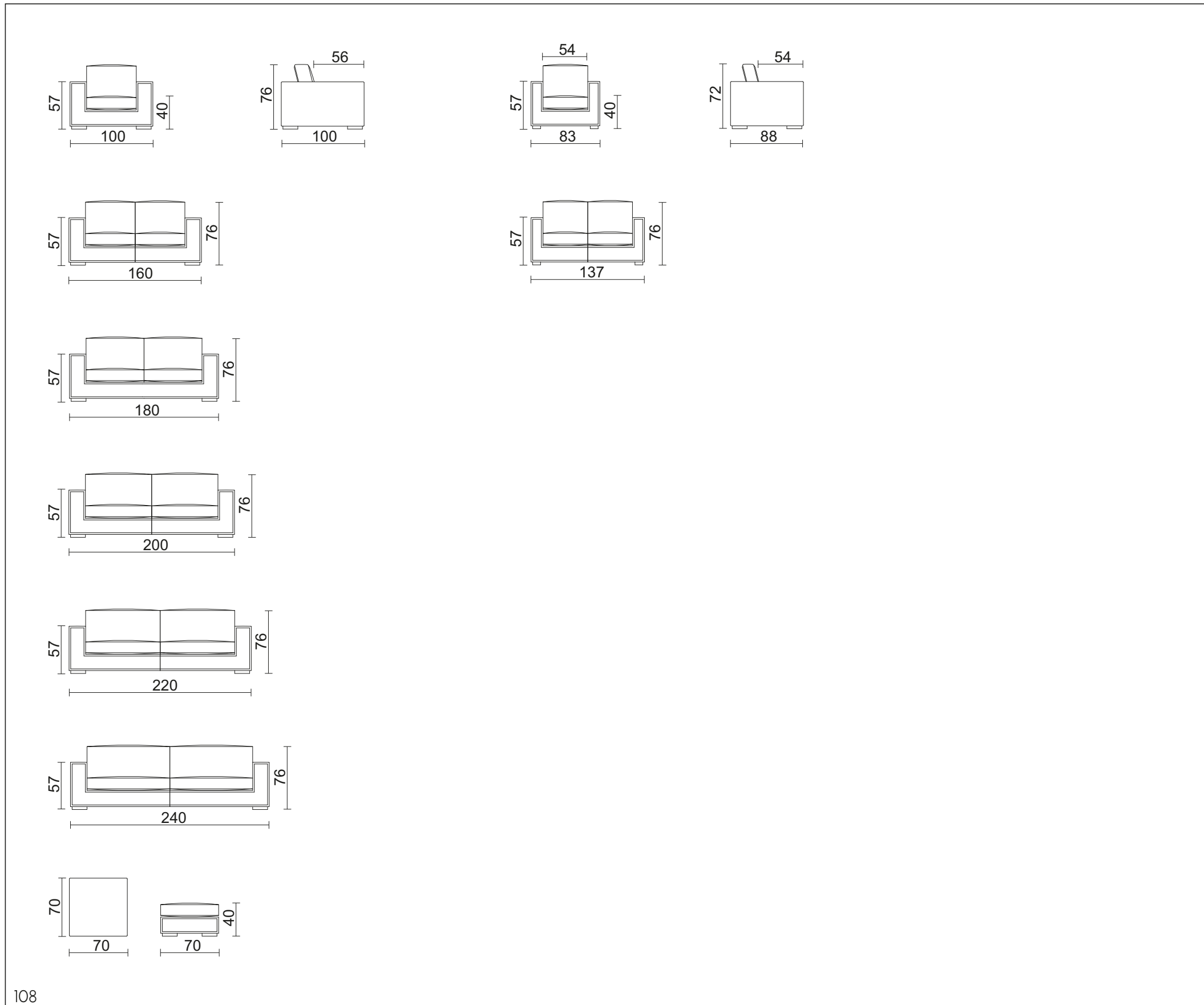

EGO design Giuseppe Viganò

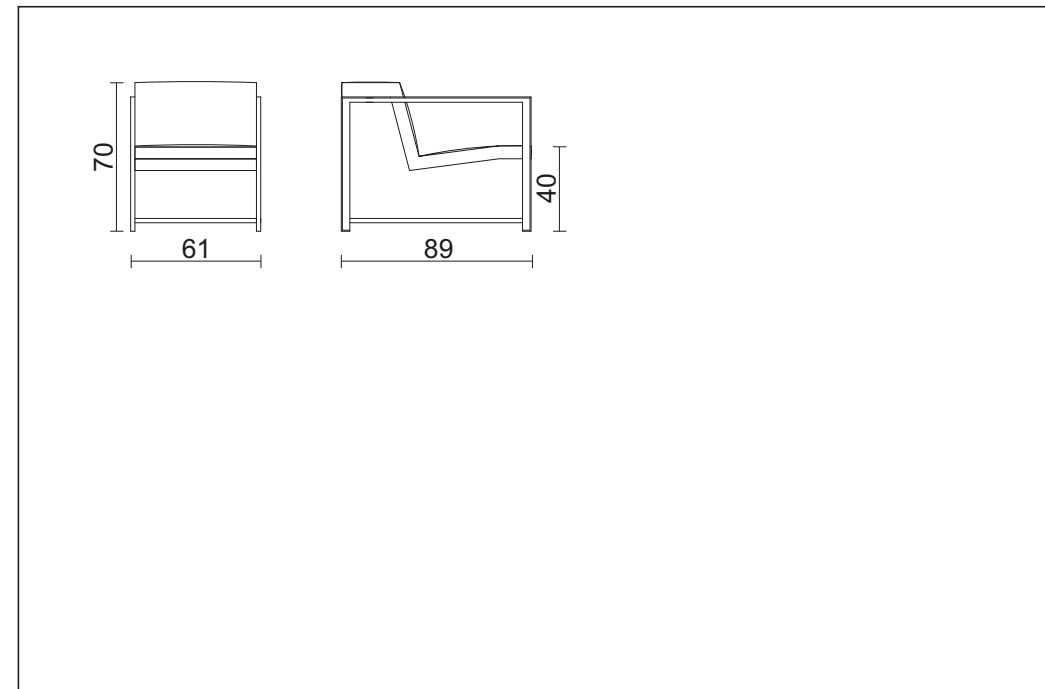



XL design Giuseppe Viganò

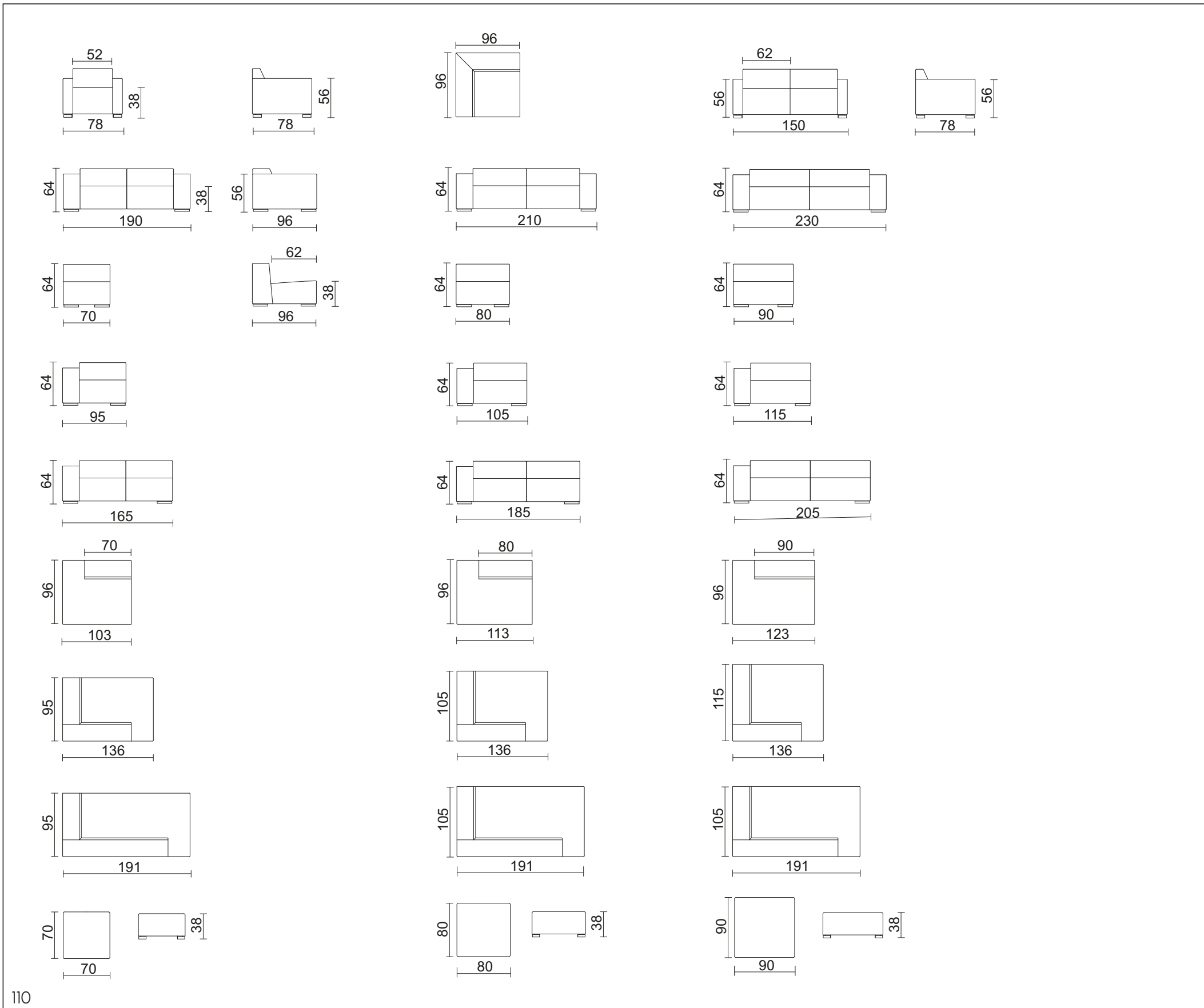

COEVO design Giuseppe Viganò

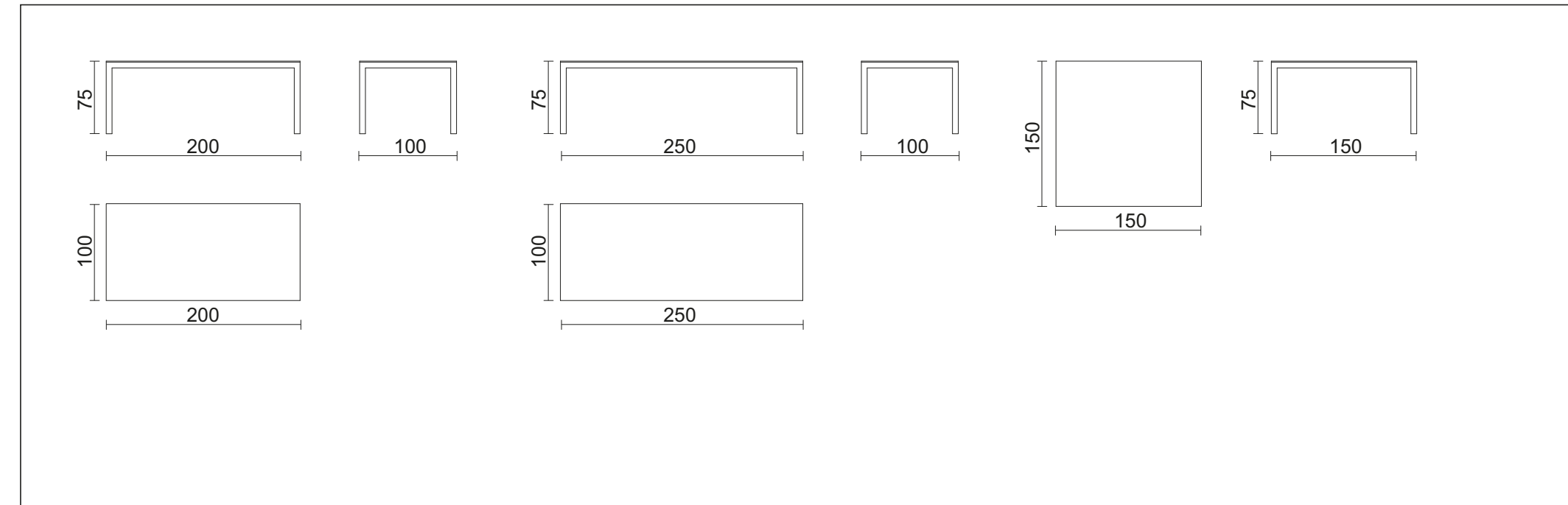

OLIMPIA design Giuseppe Viganò

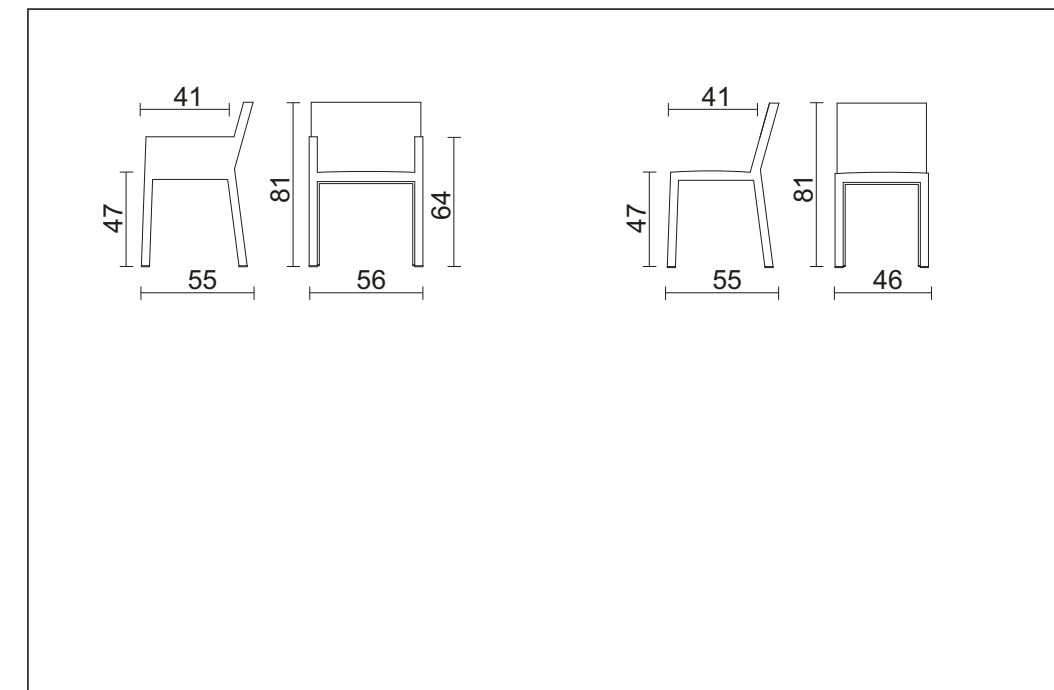

VESTA design Giuseppe Viganò

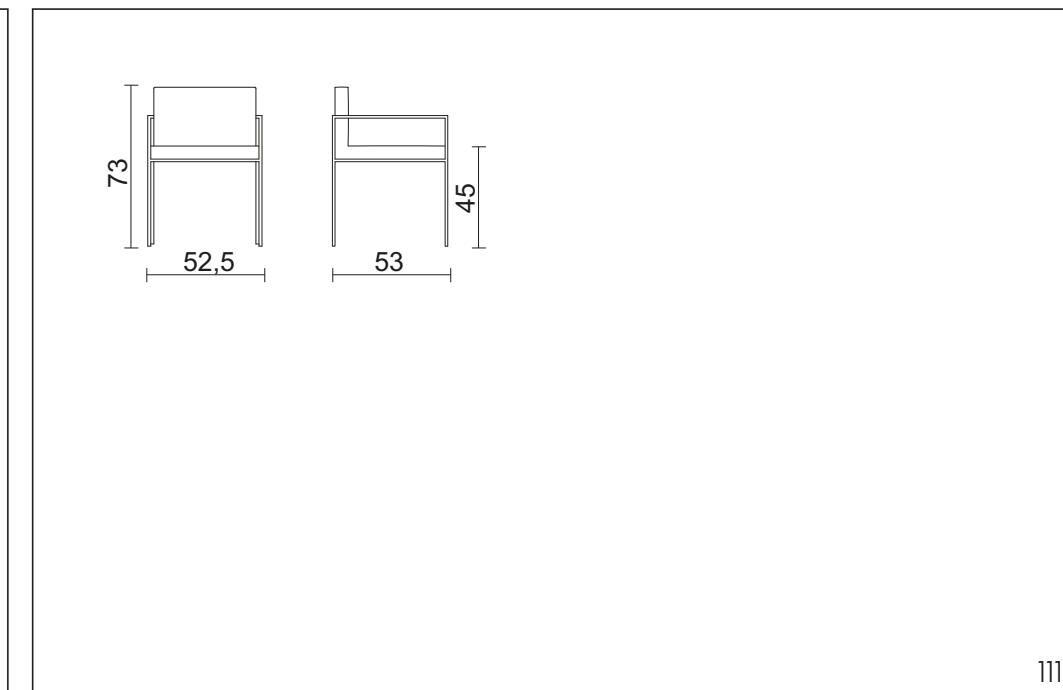



CARLOTTINA

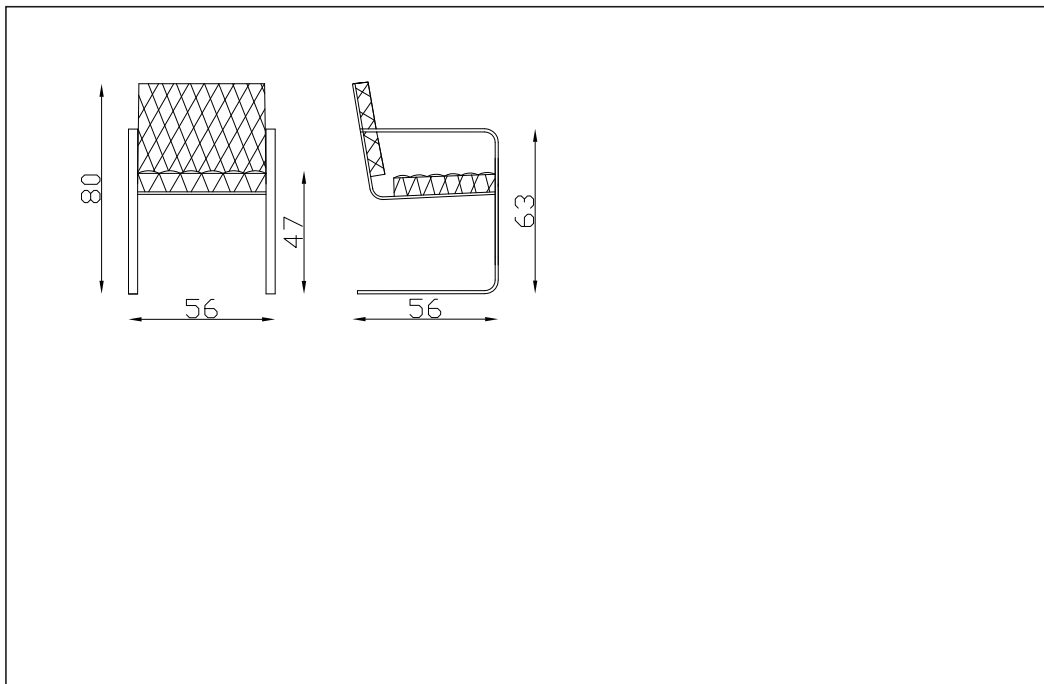

SOTTA design Giuseppe Viganò

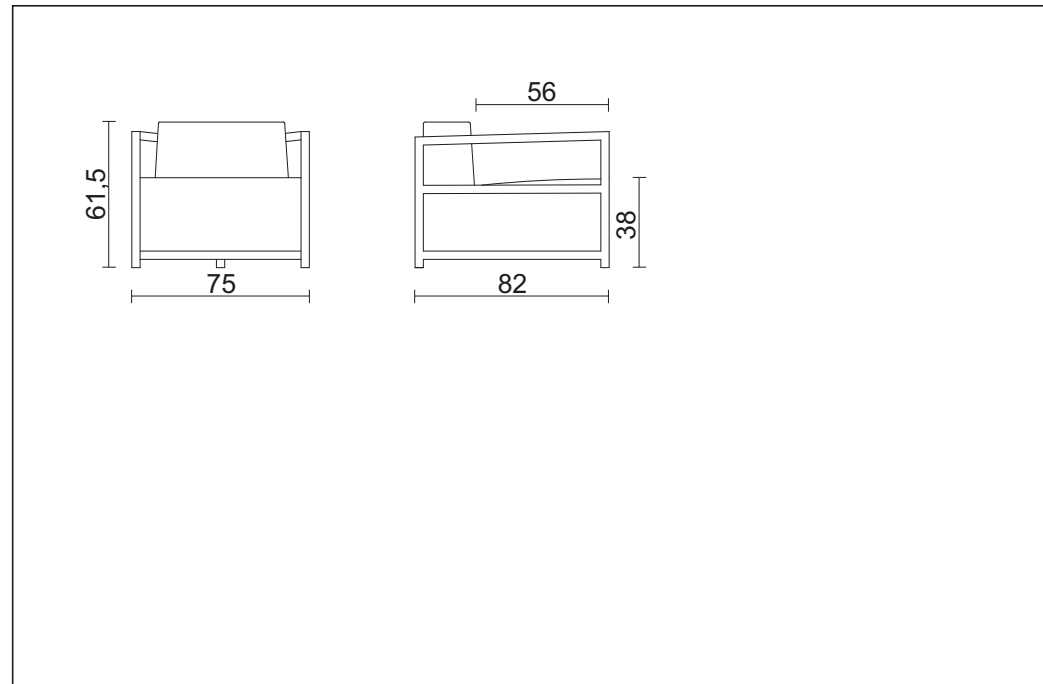

GALA design Giuseppe Viganò

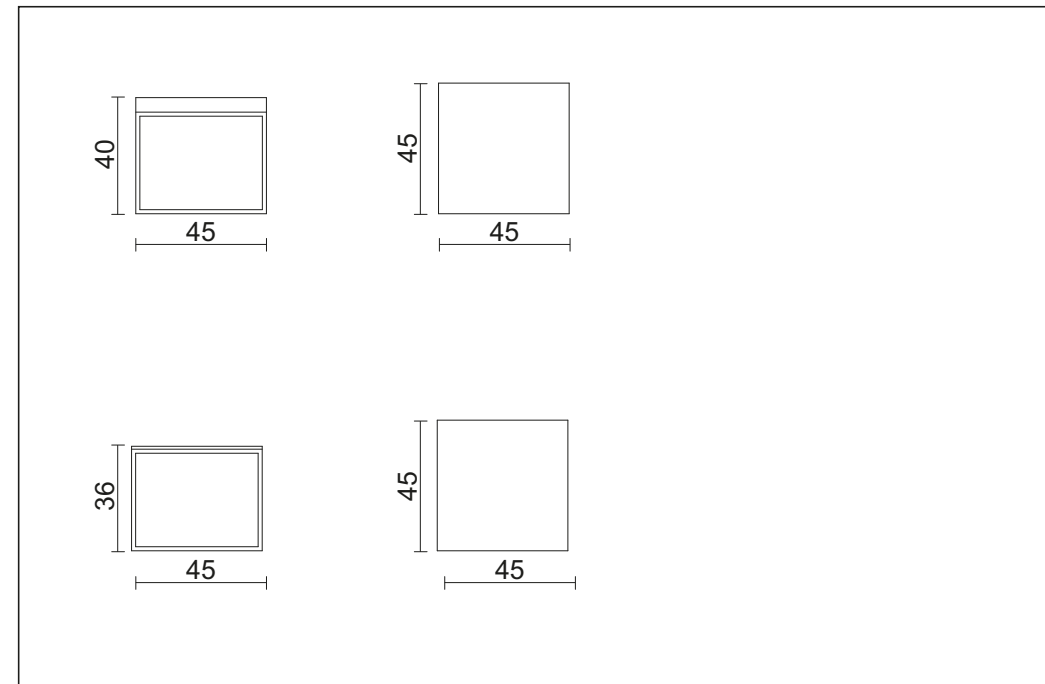

DADO design Giuseppe Viganò

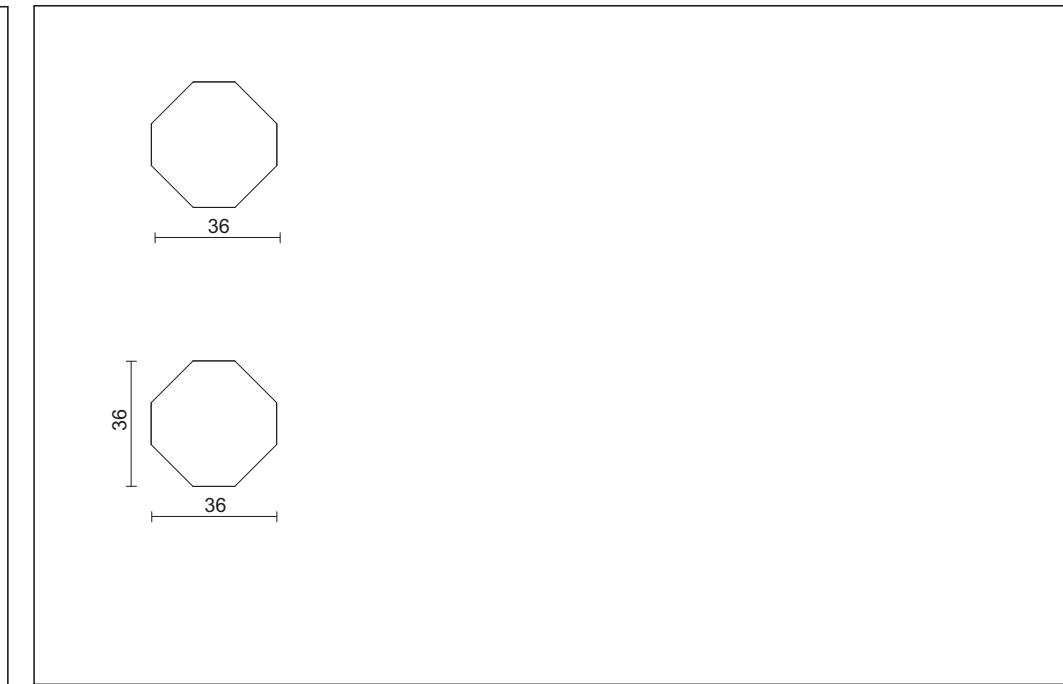

RONDÒ design Giuseppe Viganò

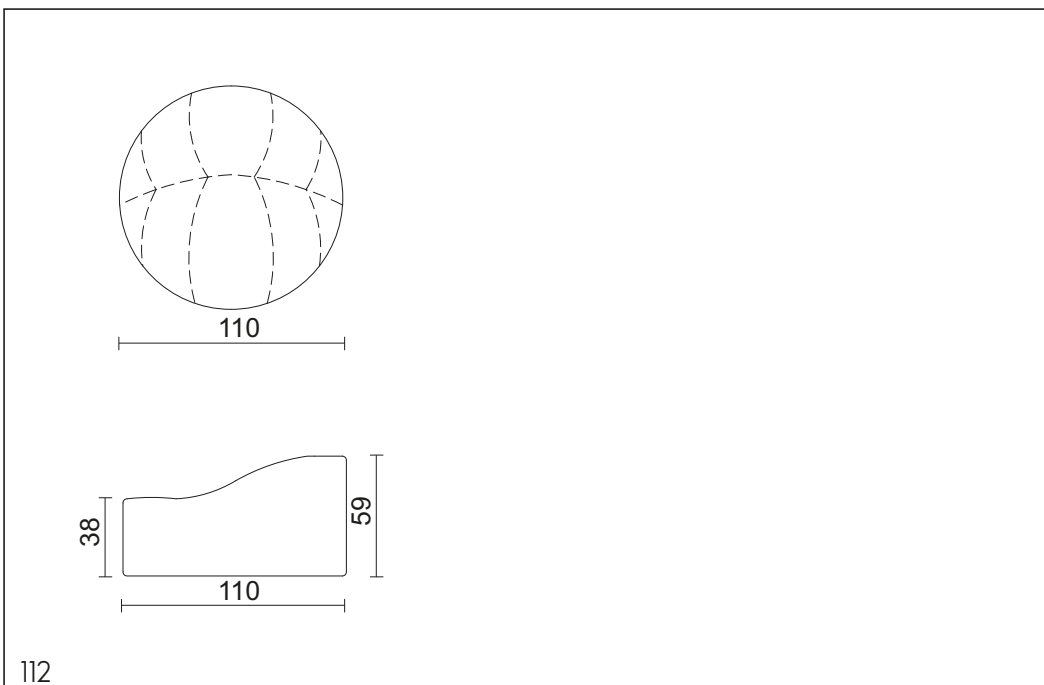

PUFFO design Giuseppe Viganò

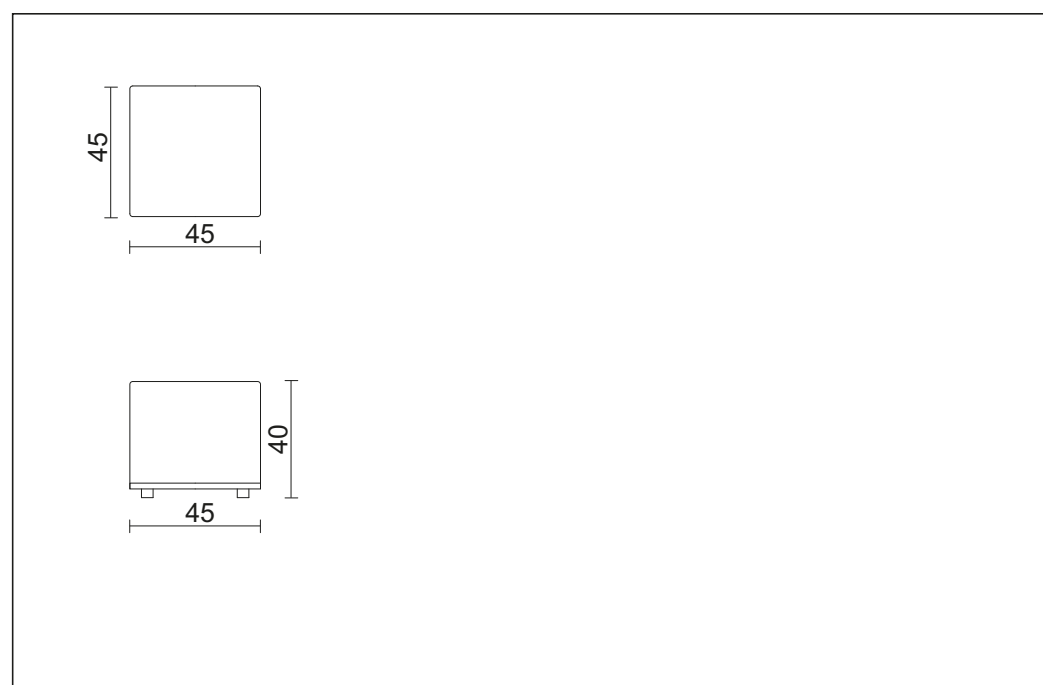

ROYAL design Daniele Lo Scalzo Moscheri

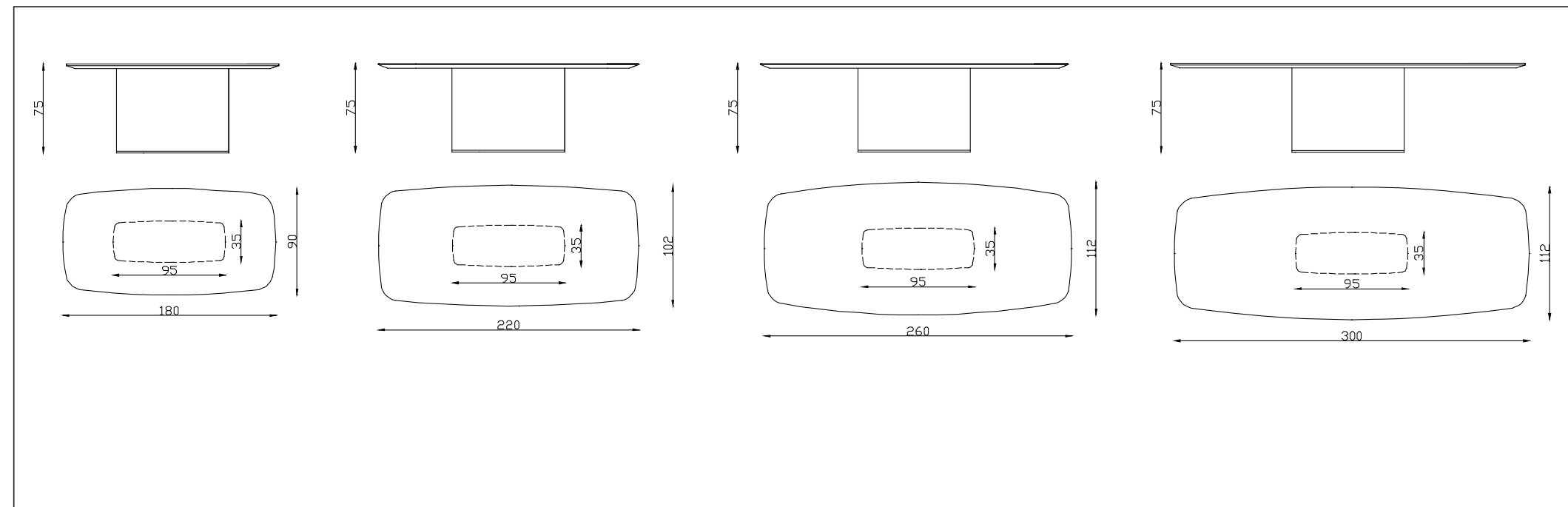



CAPITOL

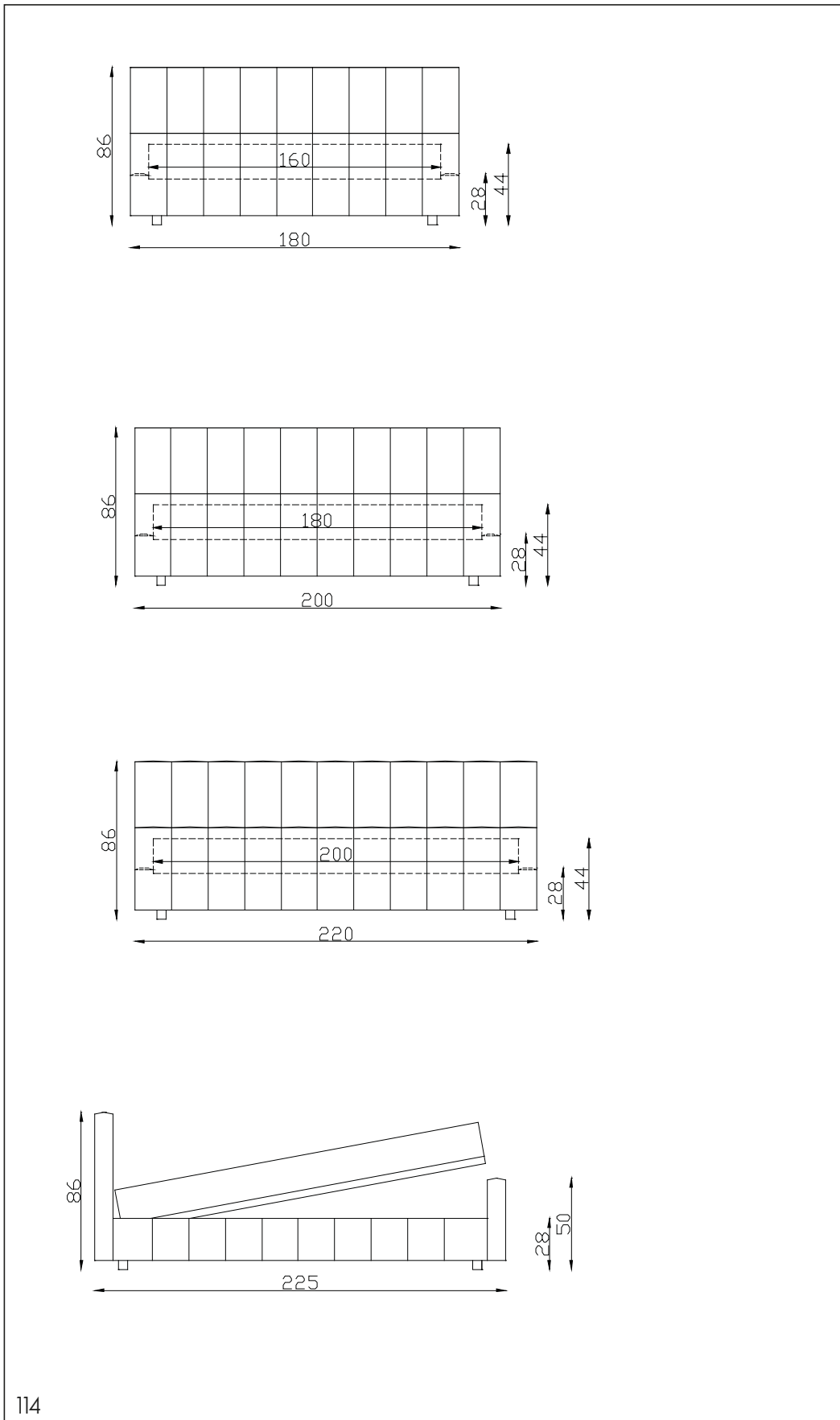

XL design Giuseppe Viganò

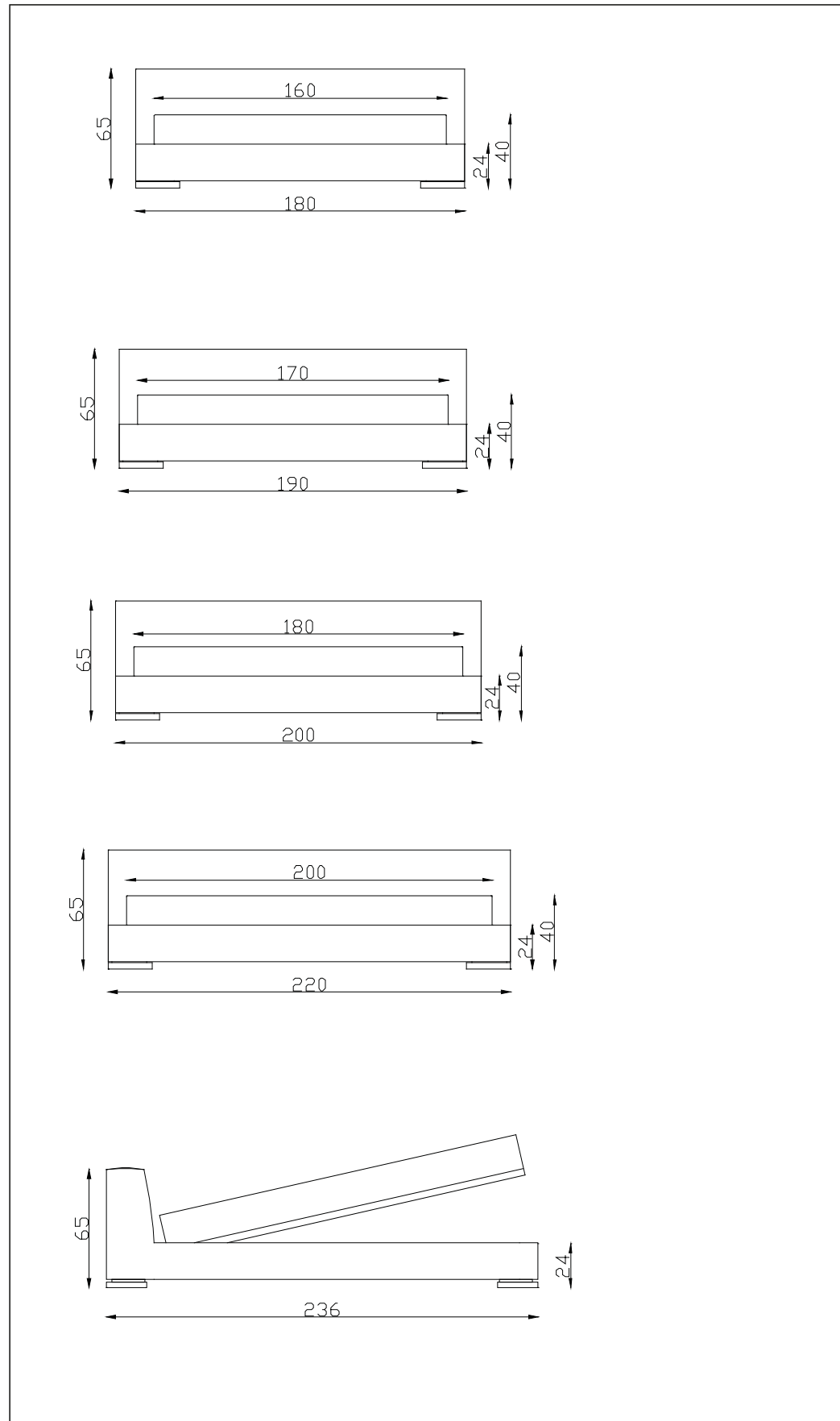

NABUCCO design Giuseppe Viganò

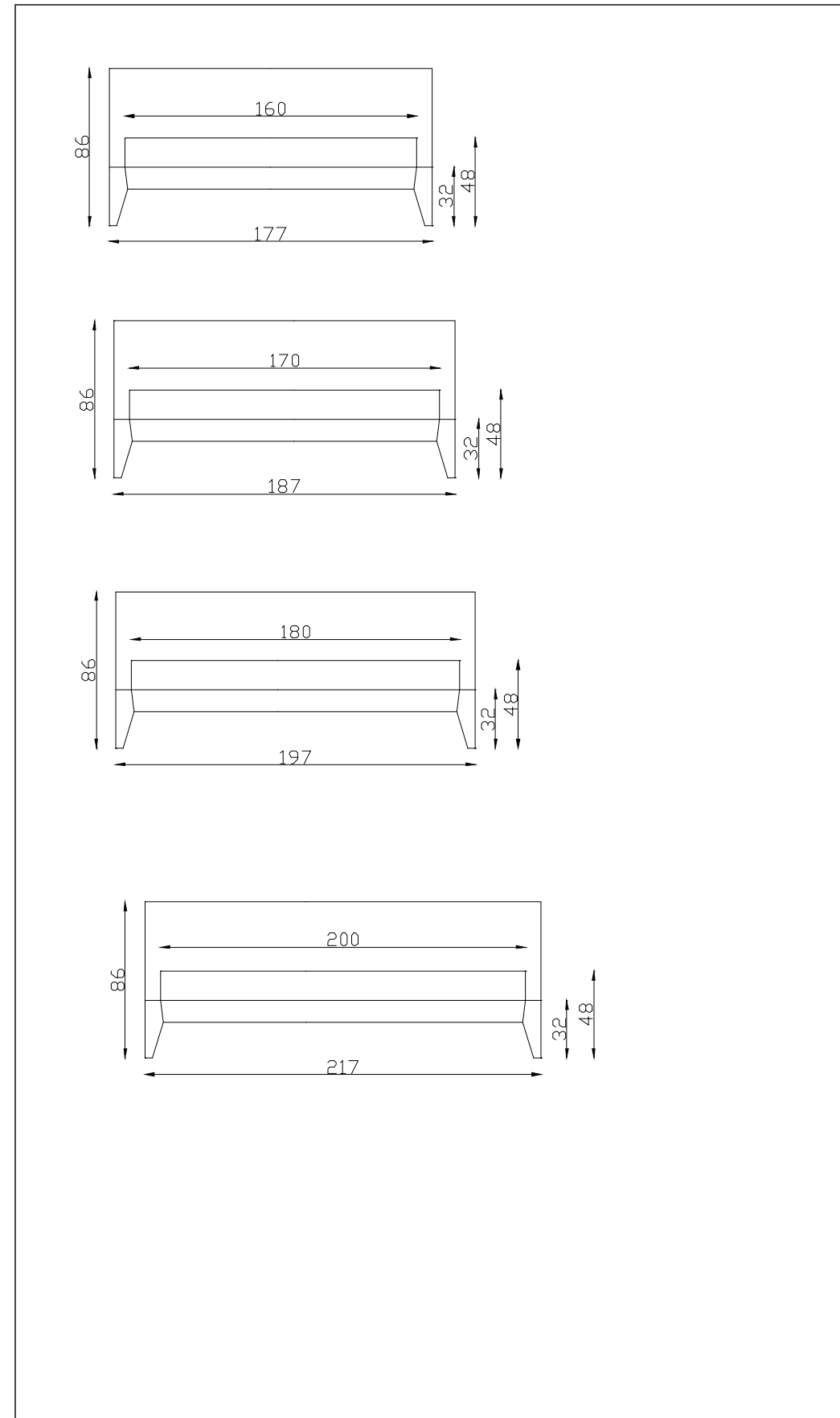

METROPOLITAN design Giuseppe Viganò

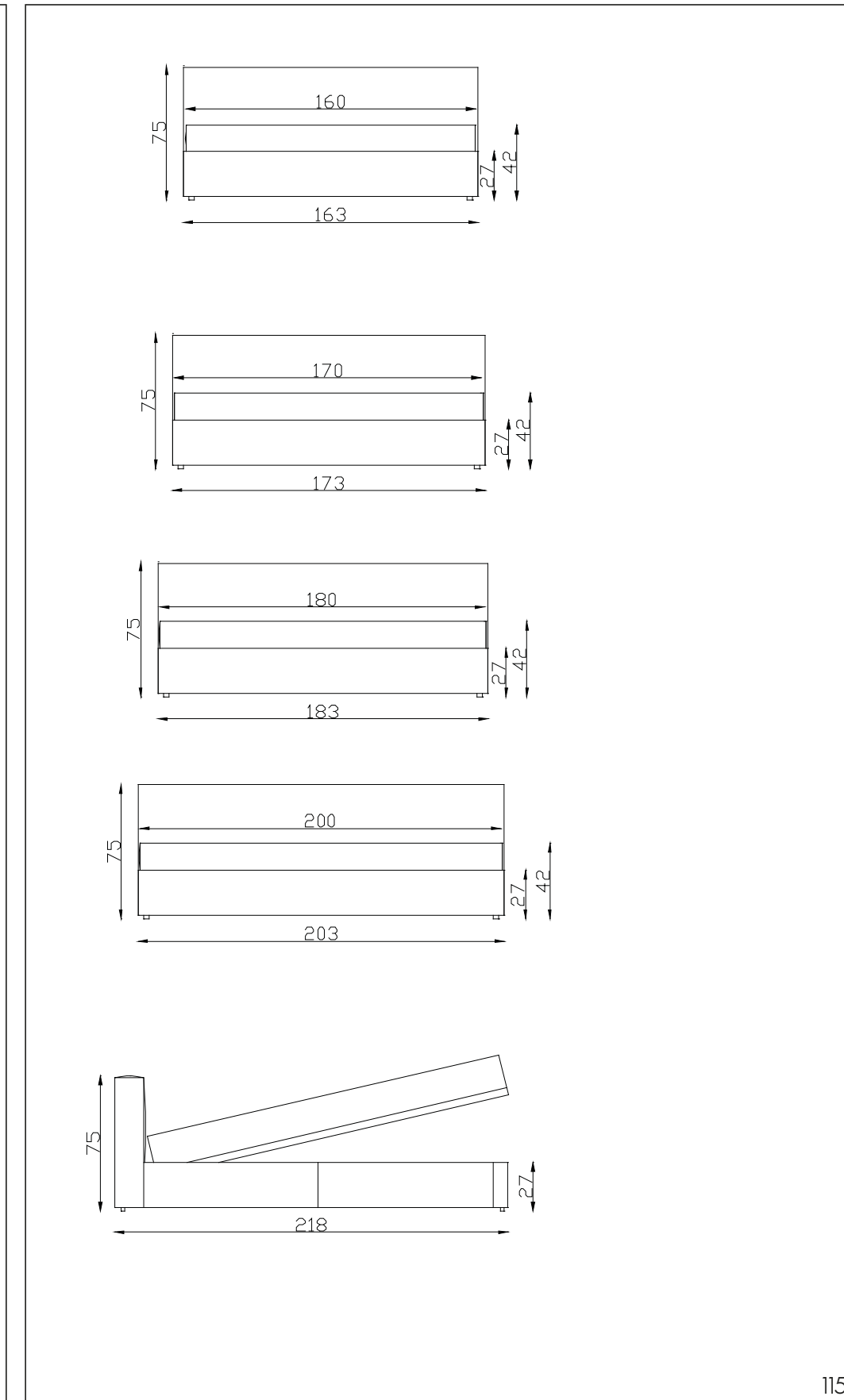



LUXURY design Giuseppe Viganò

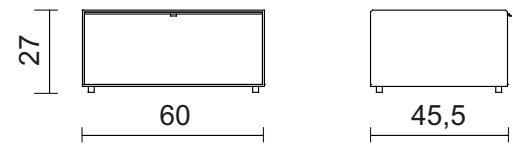
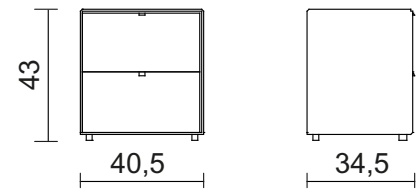
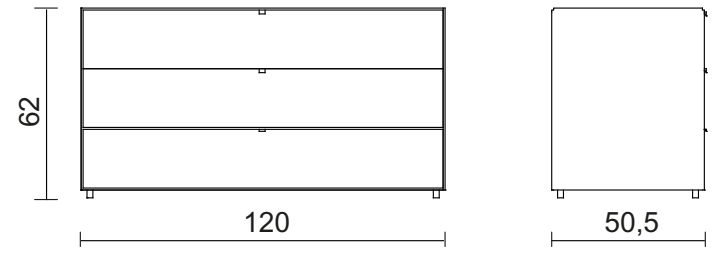

Rivolta

Rivolta s.r.l. via Caravaggio, 40 _20851 Lissone _**Mb** Italy

Ph +39 039 2455888 _Fax +39 039 2455912

info@rivoltadivani.it _www.rivoltadivani.it

www.rivoltadivani.it