

Moroso ~~1. Sofas~~
~~and seating systems~~
~~2. Single seats~~
~~and accessories~~
3. Outdoor

2nd issue

Who's Afraid of Red, Yellow and Blue,
1966-1970
Barnett Newman

Moroso ~~1. Sofas~~
~~and seating systems~~
~~2. Single seats~~
~~and accessories~~
3. Outdoor

MOROSO[®]

<u>Intro</u>	004
--------------------	-----

M'Afrique

Amaca	102/103 - 228
Arco	104/105 - 230
Banjooli	044 → 053 - 232
Baobab	057, 058/059, 064, 075 - 236
Gaal	122, 123 - 242
Husk	054 → 063 - 244
Imba	064 → 071 - 246
Iris, Ibiscus	072/073, 074, 075 - 250
Jardin Suspendu	096 → 101, 104/105 - 252
Madame Dakar	088/089 - 256
O)< Chair	076 → 083 - 262
Shadowy, Sunny	107 → 121 - 272
Toogou	085, 086, 087 - 286
Touti	090, 091 - 288
Weavers bench	093, 094/095 - 295

<u>Intro</u>	127
--------------------	-----

Forme plastique

Diatom	178 → 185 - 238
Fjord H.	218, 219 - 240
Impossible wood	205, 206, 207 - 248
Little Albert	151, 152/153, 155 - 254
Moon	144, 145, 146/147, 149 - 258
No-Waste	194, 219 - 260
Oasis	208 → 217 - 266
O-Nest	156/157, 159, 160, 161 - 264
Ripple chair	194, 195, 196, 197, 199 - 270
Shitake	221, 222/223 - 276
St. Mark	200, 201, 202, 203 - 278
Supernatural	187 → 193 - 280
The Big Easy	162, 163 - 284
Tropicalia	164 → 177 - 290

<u>Technical info</u>	224
-----------------------------	-----























































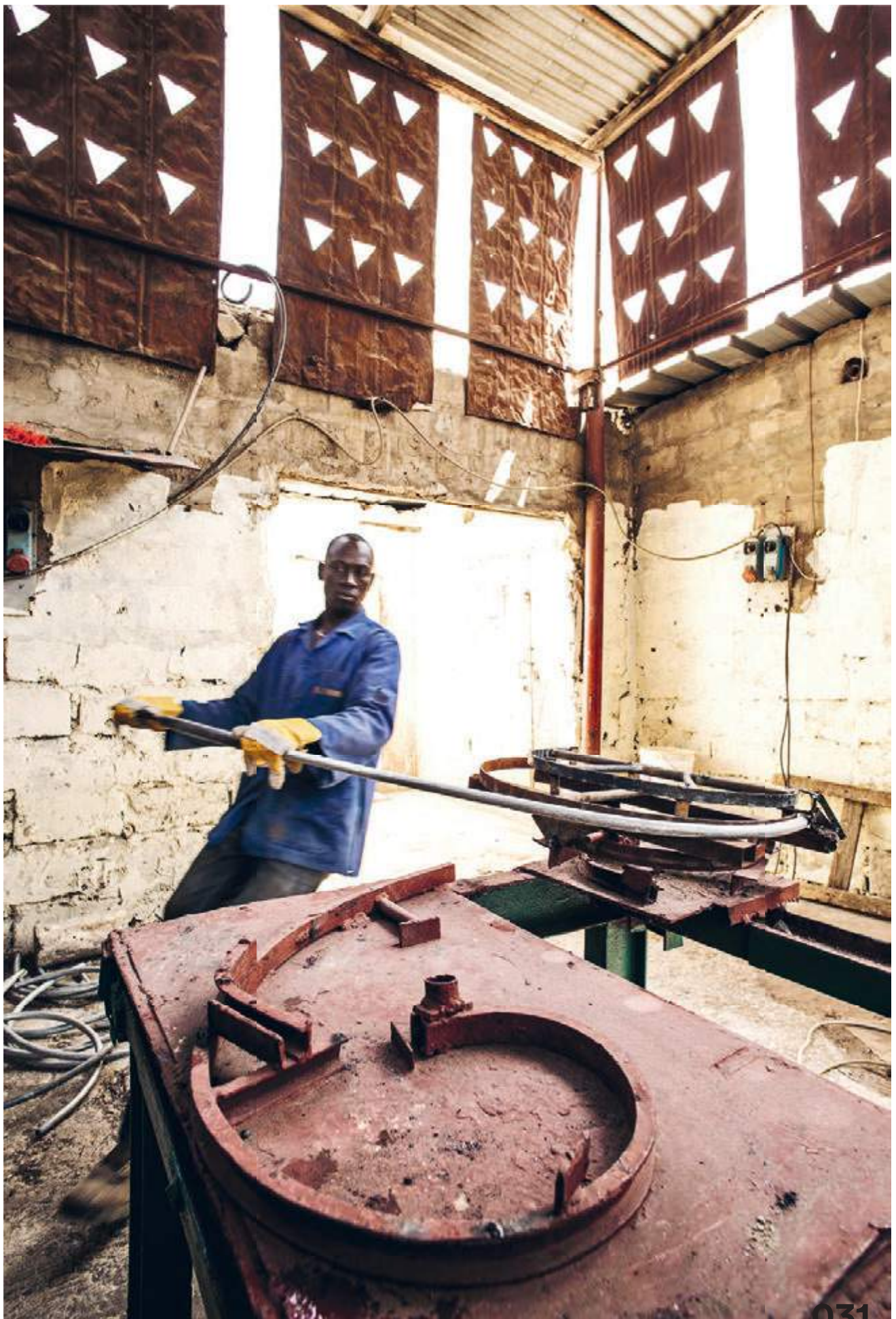







M'Afrique

Da una parte l'Africa, imponente *work in progress*, luogo dei contrasti e della provvisorietà; dall'altra l'Italia dell'operosità, della meticolosa pratica manifatturiera, della precisione industriale; il design come *trait d'union*.

Moroso M'Afrique: sedute e complementi d'arredo, oggetti come filamenti di un progetto visionario che celebrano l'intuizione e l'attitudine all'idea capovolgendo stereotipi e consuetudini.

Il design laddove non te lo aspetti. Nell'epoca del tutto virtuale, della realtà aumentata e dell'esaltazione dell'apparenza, s'intrecciano, con uno slancio vanitosamente demodé, due diverse interpretazioni della materialità. E lo spazio aperto – *l'outdoor* – non a caso diviene il territorio d'elezione di questo incontro.

Alla ricerca della performance di superficie, di nuovi materiali e finiture che contraddistinguono il mondo industrializzato e *ipermoderno*, si contrappone l'appropriazione colorata della forma da parte degli artigiani senegalesi. Una pratica spontanea e istintiva, radicata in ogni aspetto della quotidianità. Nel loro lavoro, mani e occhi si congiungono quasi a invertire

There's Africa – a massive work-in-progress, a place of contradictions and stopgaps – and there's Italy, industrious Italy, where meticulous manufacturing practices meet industrial precision. And then there's design, connecting them.

Moroso M'Afrique: seating and furnishing accessories, objects like threads of a visionary project that celebrates intuition and a talent for ideas, inverting stereotypes and conventions.

Design where you don't expect it. In an age when all is virtual, reality is augmented and appearance glorified, two different interpretations of materiality interweave with conceitedly old-fashioned élan. Unsurprisingly, the open air – the outdoors – is the place chosen for this encounter.

The search for surface performance, for new materials and finishes that distinguishes the industrialised, über-modern western world is juxtaposed with the use of colour applied to form typical of Senegalese artisans. A spontaneous, instinctive practice deeply rooted in every aspect of their day-to-day lives. In their work, their hands and eyes come together and almost switch their roles.





la propria funzione. Le mani leggono la struttura, ne colgono l'essenza; gli occhi, invece, ne delineano l'aspetto, decretandone l'immagine finale. Un altro modo di guardare il mondo, differente, più affine alla generazione che alla progettazione.

Il risultato meraviglia. Semplici intelaiature metalliche rivestite con fili colorati assumono una forza espressiva completamente nuova. Nella storia dell'uomo, l'intreccio precede la ceramica e la scrittura; nel design, segue l'idea.

Dalla ripetizione sequenziale di un semplice gesto, ogni singolo progetto diventa portatore di una singolarità, affermazione di autenticità materiale e relazionale. La diversità è evidente, nei disegni, nel linguaggio che racconta di contaminazioni culturali "ancora" volutamente (e piacevolmente) umane. Un processo accomodante che garantisce la riproducibilità assimilando errori e imprecisioni e che il designer, testimone di una tradizione legata alla produzione seriale, nobilita sul piano concettuale.

Ogni nuovo progetto, al di là delle infinite declinazioni possibili, si presenta così come la traccia germinale del successivo, frazione di una sequenza che, contrariamente all'esaltazione agonistica dell'innovazione, accomuna tutti – artigiani, progettisti e fruitori finali.

Senza nessuna pretesa, ma solo con un'incondizionata disposizione alla bellezza.

Their hands read the structure and grasp its essence, while their eyes define its look and decide its final image. Another, different way of seeing the world, more akin to generating than designing.

The result is pure wonder. Simple metal frames covered with coloured threads take on a totally new expressive power. In the history of Man, weaving precedes pottery and writing; in design, it follows the idea.

With the sequential repetition of a simple action, each creation becomes unique, and a statement of material and relational authenticity. Diversity is clearly seen in the patterns and in the language, which speaks of cultural contaminations that are "still" deliberately (and agreeably) human. An accommodating, replicable process, in which mistakes and inaccuracies are tolerated and absorbed and which the designer, linked to a tradition of mass production, dignifies on a conceptual level.

Beyond the endless possible variations, each new project is like a germinal trace of the next one, a fraction of a sequence that, unlike the competitive side of innovation, brings everyone together – artisans, designers and end users.

It's design at its unassuming best, animated by nothing but an unconditional bent for beauty.

[Lorenzo Taucer]





Banjooli



Banjooli | design Sebastian Herkner | 2013

Moroso Outdoor

M'Afrique

~~Forme plastique~~

~~Technical~~

info



Banjooli



Banjooli design Sebastian Herkner — 2013

Banjooli

Moroso vol 3/3 Outdoor



Banjooli design Sebastian Herkner — 2013



Banjooli

Moroso vol 3/3 Outdoor



Banjooli design Sebastian Herkner — 2013





Banjooli



Banjooli design Sebastian Herkner — 2013



Outdoor

Moroso vol 3/3





Husk

Husk design Marc Thorpe — 2015



Husk

Moroso vol 3/3 Outdoor

Husk design Marc Thorpe — 2015

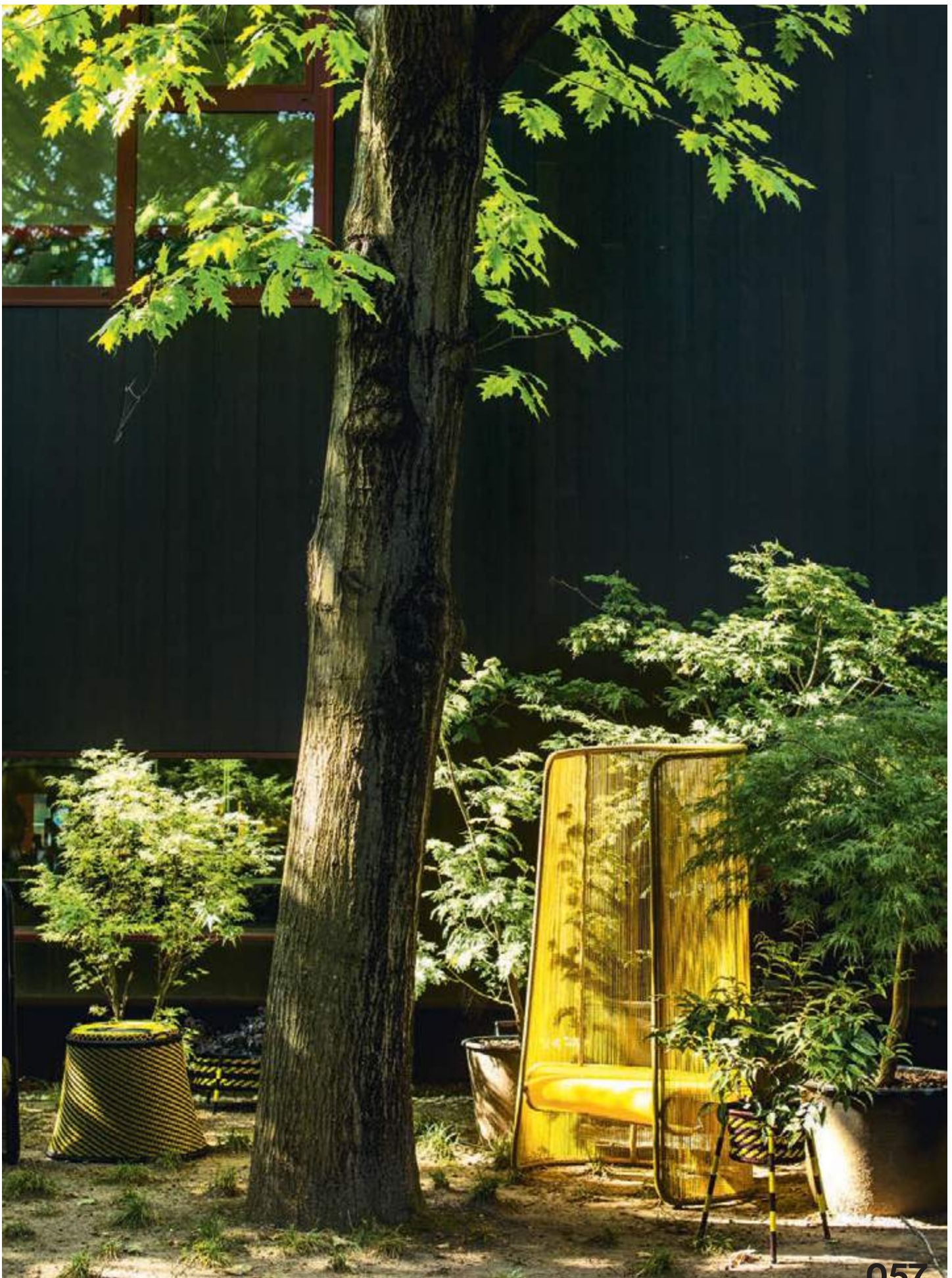





Husk

Moroso vol 3/3 Outdoor





Husk design Marc Thorpe — 2015





Husk design Marc Thorpe — 2015









Imba

Moroso vol 3/3 Outdoor





Iris, Ibiscus

Moroso vol 3/3 Outdoor





Iris, Ibiscus design. Dominique Petot — 2009

Iris, Ibiscus

Moroso vol 3/3 Outdoor



Iris, Ibiscus design Dominique Petot — 2009







O)< Chair

Outdoor

Moroso vol 3/3

O)< Chair design Tord Boontje — 2016











O) < Chair

O) < Chair design Tord Boontje — 2016

Toogou

Outdoor

Moroso vol 3/3

Toogou design Aysel Birsel & Bibi Seck — 2009

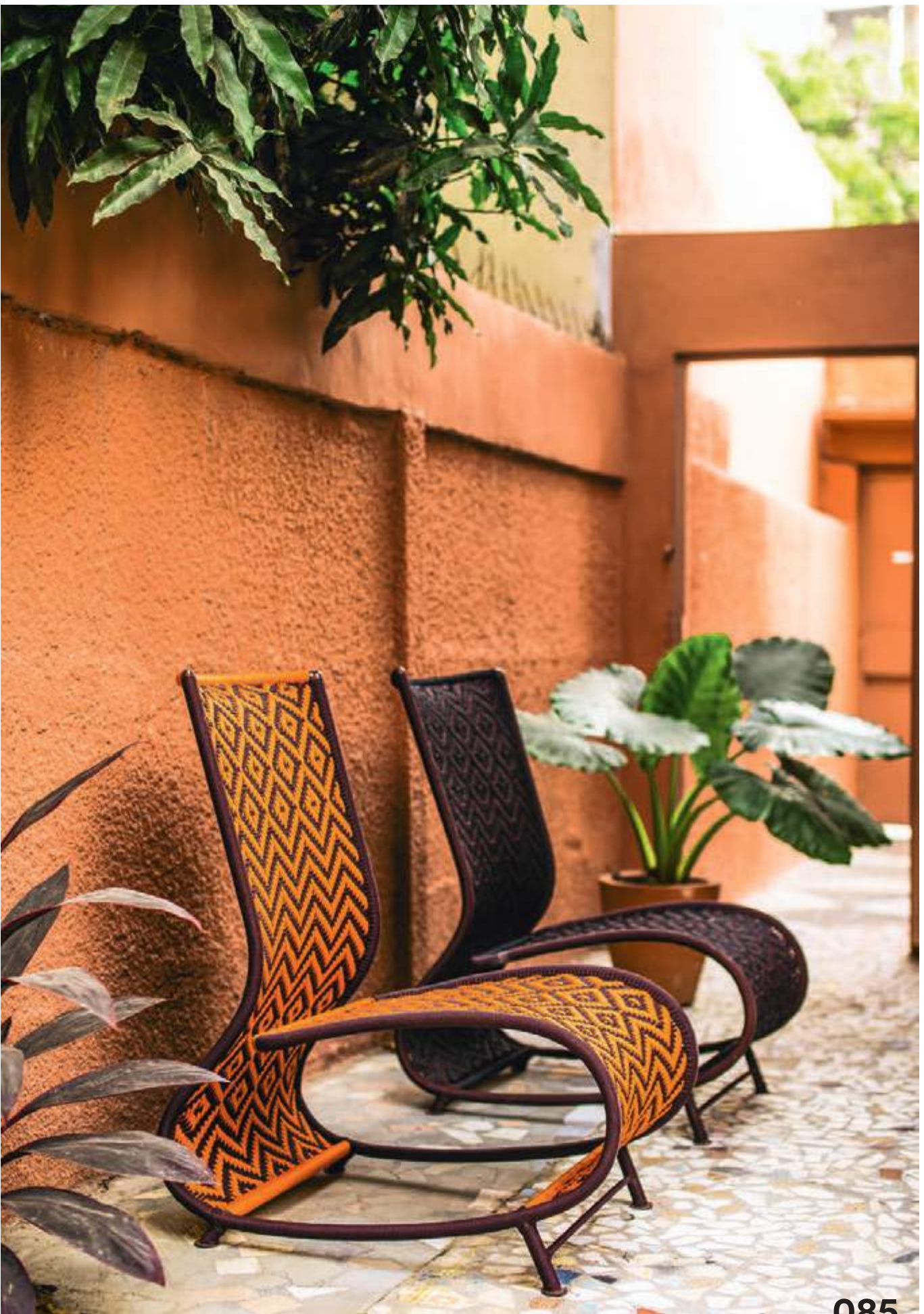



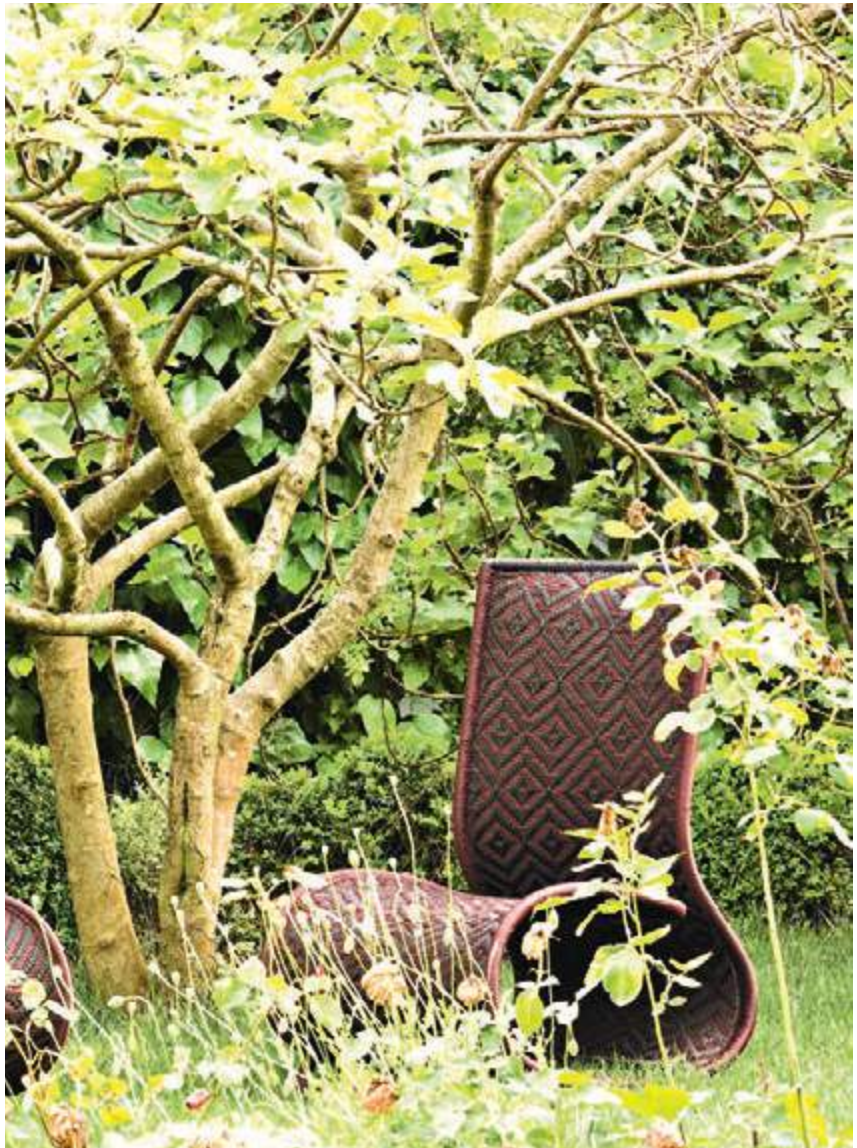

Madame Dakar

Moroso vol 3/3 Outdoor





Madame Dakar design Patricia Urquiola — 2009

Touti

Moroso vol 3/3 Outdoor



Touti design Patricia Urquiola — 2009



Weavers Bench

Moroso vol 3/3 Outdoor



Weavers Bench design Tord Boontje — 2016



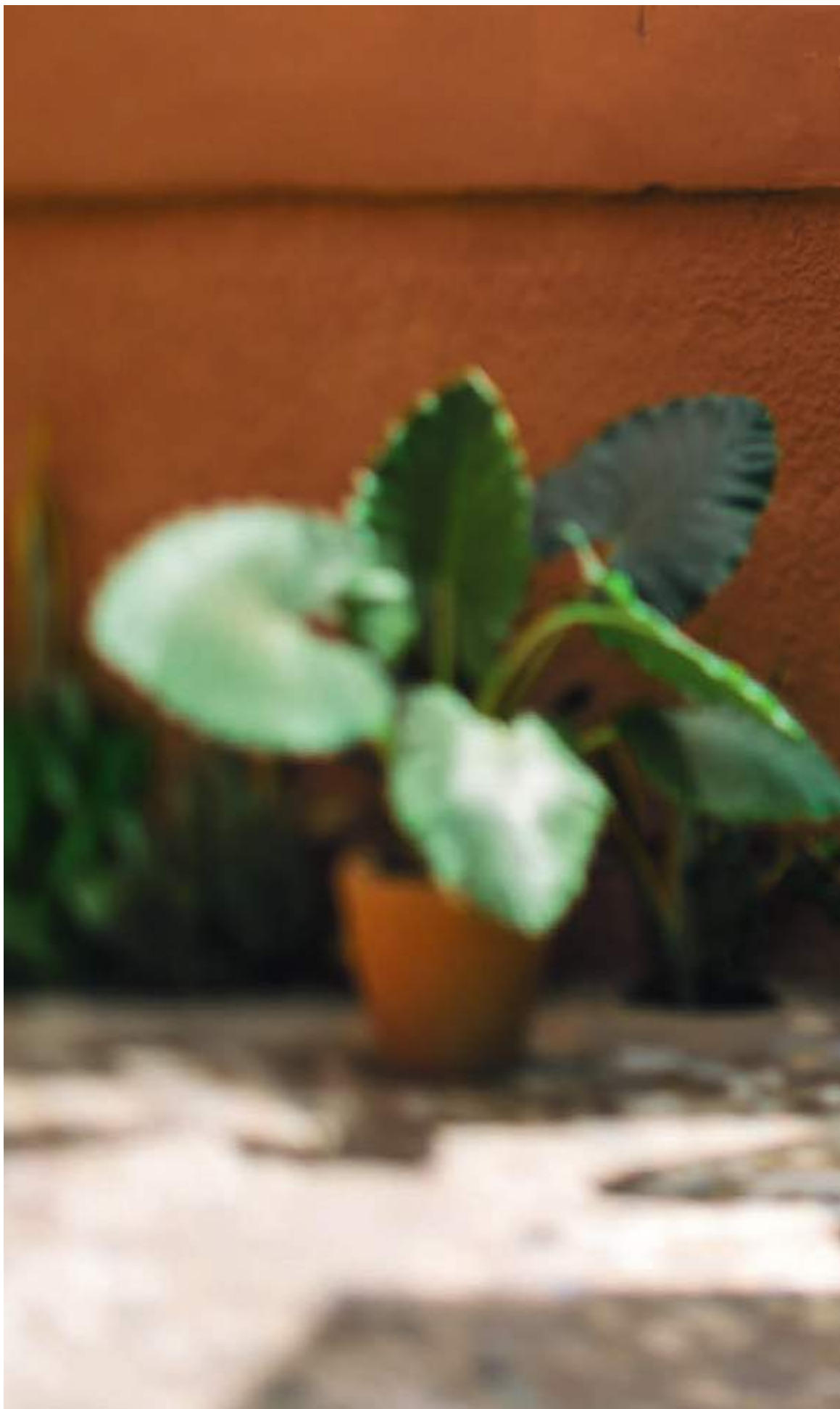

Weavers Bench

Weavers Bench design Tord Boontje — 2016



Jardin Suspendu

Moroso vol 3/3 Outdoor



Jardin Suspendu design Concetta Giannangeli — 2016





Jardin Suspendu



Jardin Suspendu design Concetta Giannangeli — 2016

Jardin Suspendu

Moroso vol 3/3 Outdoor



Jardin Suspendu design Concetta Giannangeli — 2016











Shadowy

Moroso vol 3/3 Outdoor

Shadowy design Tord Boontje — 2009





Shadowy

Shadowy design Tord Boontje — 2009











Sunny design Tord Boontje — 2009

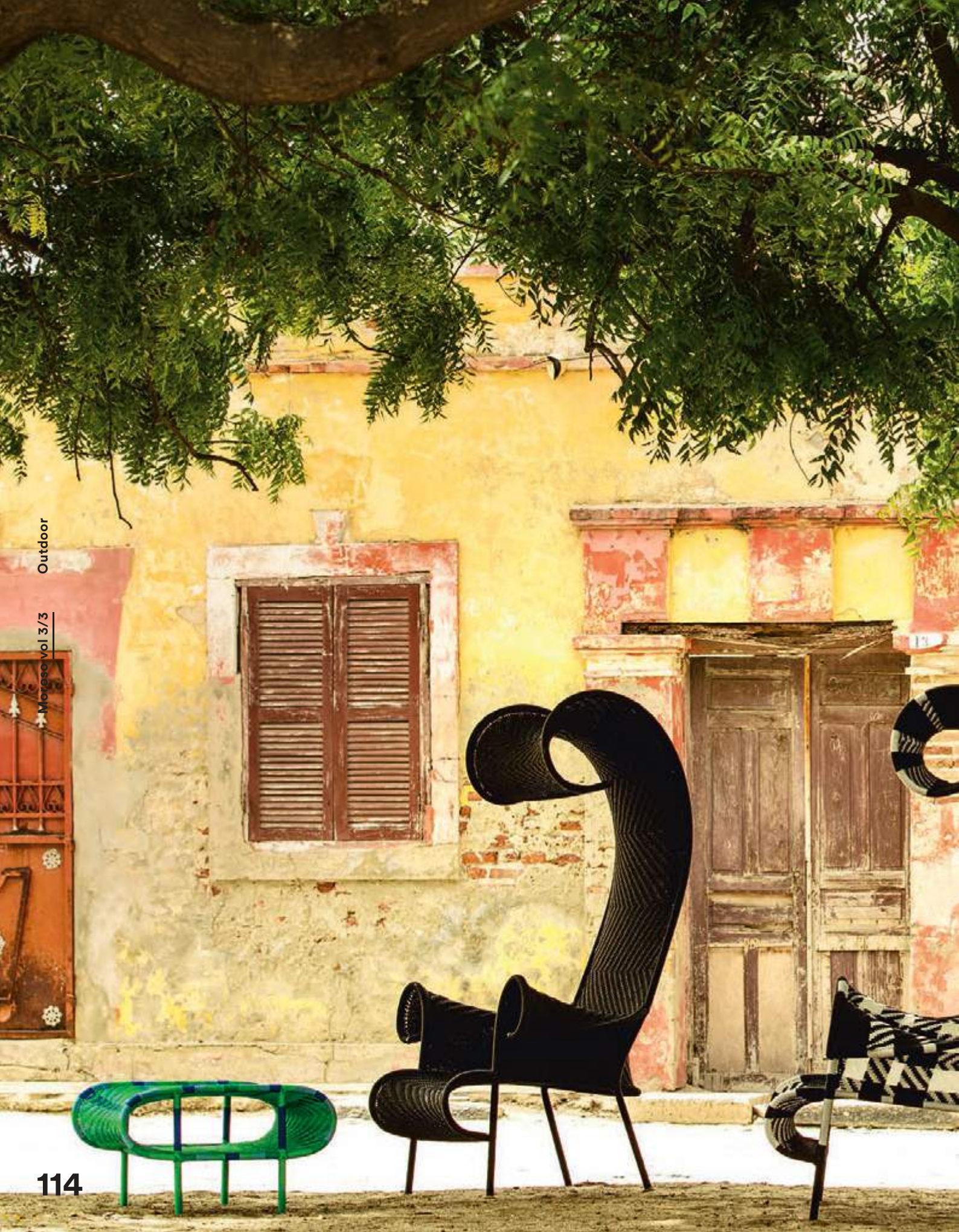

Shadowy

Shadowy design Tord Boontje — 2009



Shadowy

Moroso vol 3/3 Outdoor



Shadowy design Tord Boontje — 2009









Shadowy

Shadowy design Tord Boonje — 2009



Gaal

Moroso vol 3/3 Outdoor



Gaal design Ayse Birsel & Bibi Seck — 2009







Moroso Outdoor

~~M'Afrique~~

Forme plastique

~~Technical~~

info



Forme plastique
L'espressione matematica
della bellezza

“Non riesco a capire perché le persone siano spaventate dalle nuove idee. A me spaventano quelle vecchie”

L'abilità del designer, per certi aspetti, ricorda quella del matematico. Entrambi agiscono con un pensiero creativo, arrivando al risultato finale attraverso una serie di approssimazioni successive; entrambi sanno combinare l'intuizione con la dimostrazione.

Nella matematica non c'è *bluff*; per risolvere un problema è necessario trovare la soluzione. E ogni soluzione identificata dischiude una nuova prospettiva sugli sviluppi del pensiero matematico.

Così, anche nella produzione industriale.

Forme plastique
The mathematical expression
of beauty

“I can't understand why people are frightened of new ideas. I'm frightened of the old ones”

John Cage
[Conversing with Cage, Richard Kostelanetz 1988]

In some ways, a designer's and a mathematician's abilities are similar. They both harness creative thought to arrive at a final result through a sequence of approximations. Both are able to combine intuition with proof.

There's no bluffing in maths; you have to find the solution to solve a problem. And each solution reveals a new perspective on the developments of mathematical thought.

The same applies to industrial production.









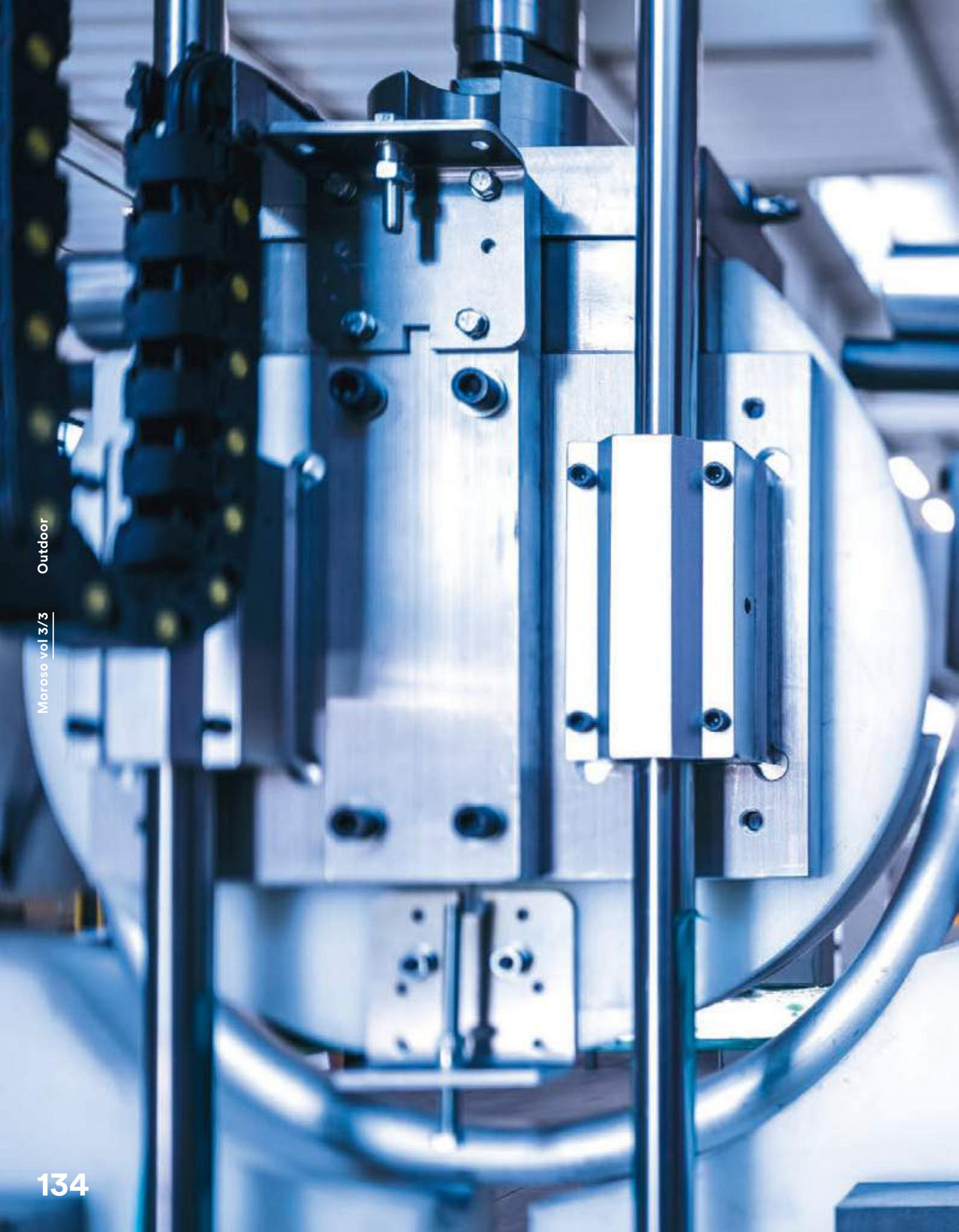







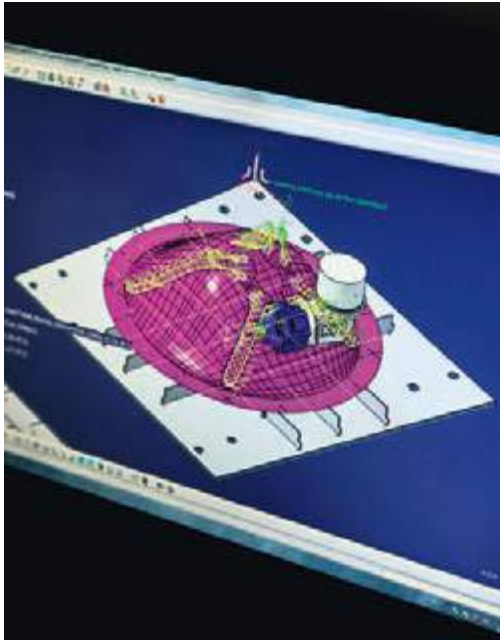

Nel contesto del design, la forma non è mai la conseguenza meccanica di una lavorazione. Ogni materiale, conosciuto o nuovo che sia, presenta condizioni di utilizzo particolari; per progettare bisogna conoscere le variabili, le possibilità e i limiti di ogni materia prima. Un processo complesso costituito da una moltitudine di fattori, ognuno dei quali concorre alla realizzazione del prodotto finito.

Se il prodotto esiste, il processo è compiuto.

In tutto questo, la conoscenza è un fattore determinante. Dal confronto materiale tra progettista e produttore, dall'accettazione delle ragioni dell'altro, dall'istinto che inevitabilmente porta ad affrontare sfide ritenute impossibili, nasce l'innovazione. Una modalità operativa che dimostra come alla base di alcuni prodotti, il *know-how*, la concretezza del fare, sia determinante tanto quanto la capacità immaginativa.

As far as design is concerned, form is never the mechanical consequence of a certain processing. Each element, be it new or already known, requires specific usage conditions. When designing, you need to know the variables, possibilities and limits of each raw material. A complex process involving multiple factors, each contributing to the finished product.

If the product exists, the process is completed.

Knowledge is a determining factor in all this. From a one-on-one meeting between the designer and the manufacturer, from each accepting the motives of the other, from the instinct which inevitably leads to accepting challenges that are deemed impossible, comes innovation. A working method which demonstrates that know-how and solid expertise are as important to some products as a capacity for imagining.

Una fusione tra competenza tecnica e sensibilità stilistica che, senza contraddire il concetto di serie, trasforma il prodotto industriale in qualcosa di unico, di formalmente autentico. Il valore funzionale, pratico e strumentale, si sovrappone alla dimensione estetica, fino a coinciderne. Progetti che, come i problemi risolti della matematica, schiudono nuovi orizzonti di ricerca, dilatando lo spazio compreso tra l'effettività della materia e la vitalità astratta della visione.

Oggetti archetipi, espressione e testimonianza delle differenti visioni del mondo che il designer immagina e crea assieme a tutte le persone coinvolte nelle diverse fasi di realizzazione di un prodotto, e che grazie all'idealismo e alla determinazione di pochi imprenditori, diventano parte di un immaginario collettivo sempre più globale e transculturale.

A blend of technical skill and style sensitivity that, without being contrary to the idea of mass production, transforms an industrial product into something unique and formally authentic. Its functional, practical and instrumental value overlaps with its aesthetic dimension and, ultimately, matches it. Just like the solution of a mathematical problem, these projects pave the way for new research paths, expanding the space between the tangibility of matter and a vision's abstract vitality.

Archetypal objects, the expression of and witnesses to the different visions of the world which a designer imagines and creates together with all the people involved in the various phases of product manufacturing. It is thanks to the idealism and determination of a few entrepreneurs that those objects become part of an increasingly global, cross-cultural collective imagination.

[Lorenzo Taucer]



Moroso Outdoor

~~M'Afrique~~

Forme plastique

~~Technical~~

info

Moon

Moroso vol 3/3 Outdoor



Moon design Tokujin Yoshioka — 2011







Moon

Moroso vol 3/3 Outdoor

Moon design Tokujin Yoshioka — 2011

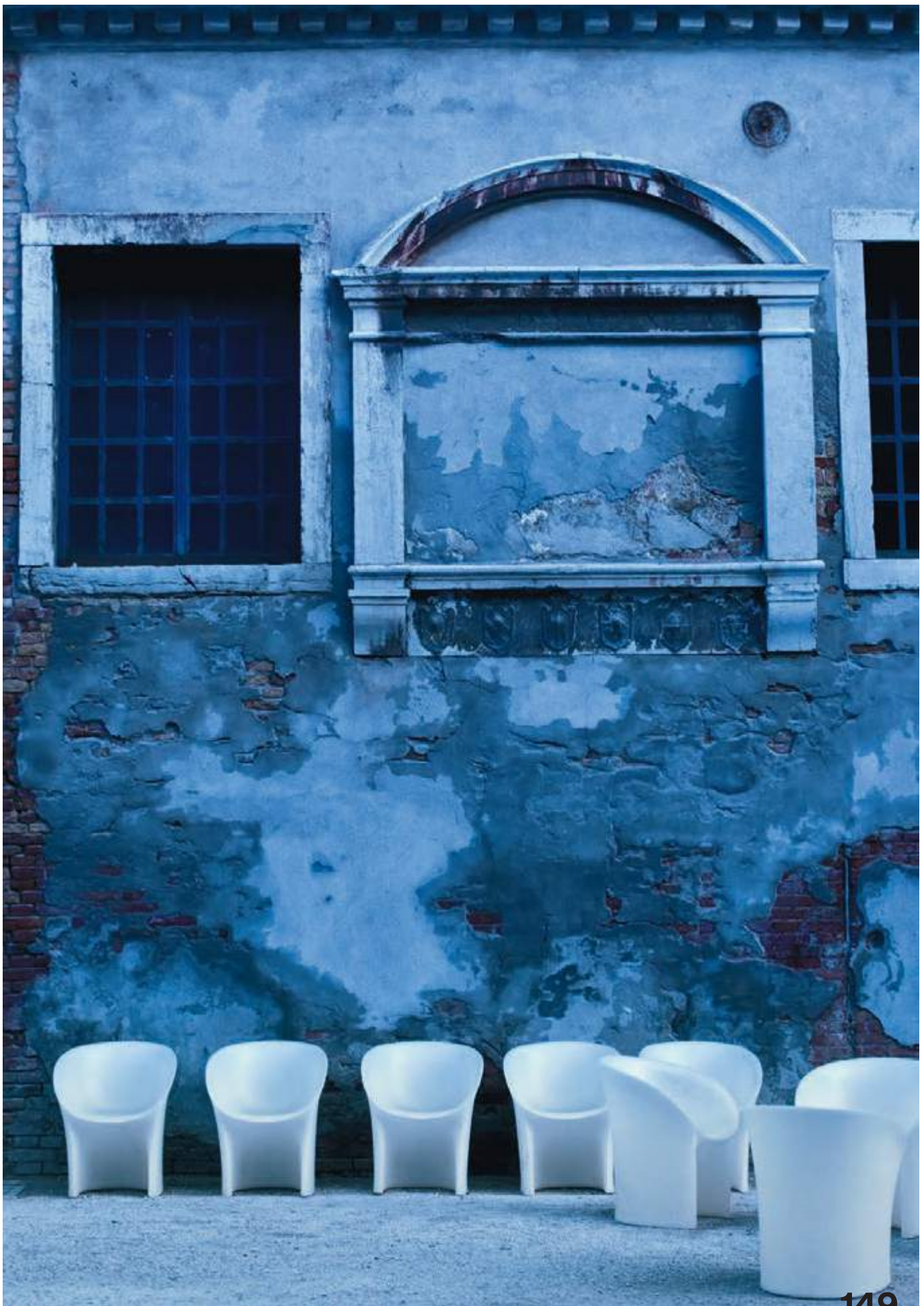

Little Albert

Outdoor

Moroso vol 3/3

Little Albert design Ron Arad — 2000



Little Albert

Moroso vol 3/3 Outdoor

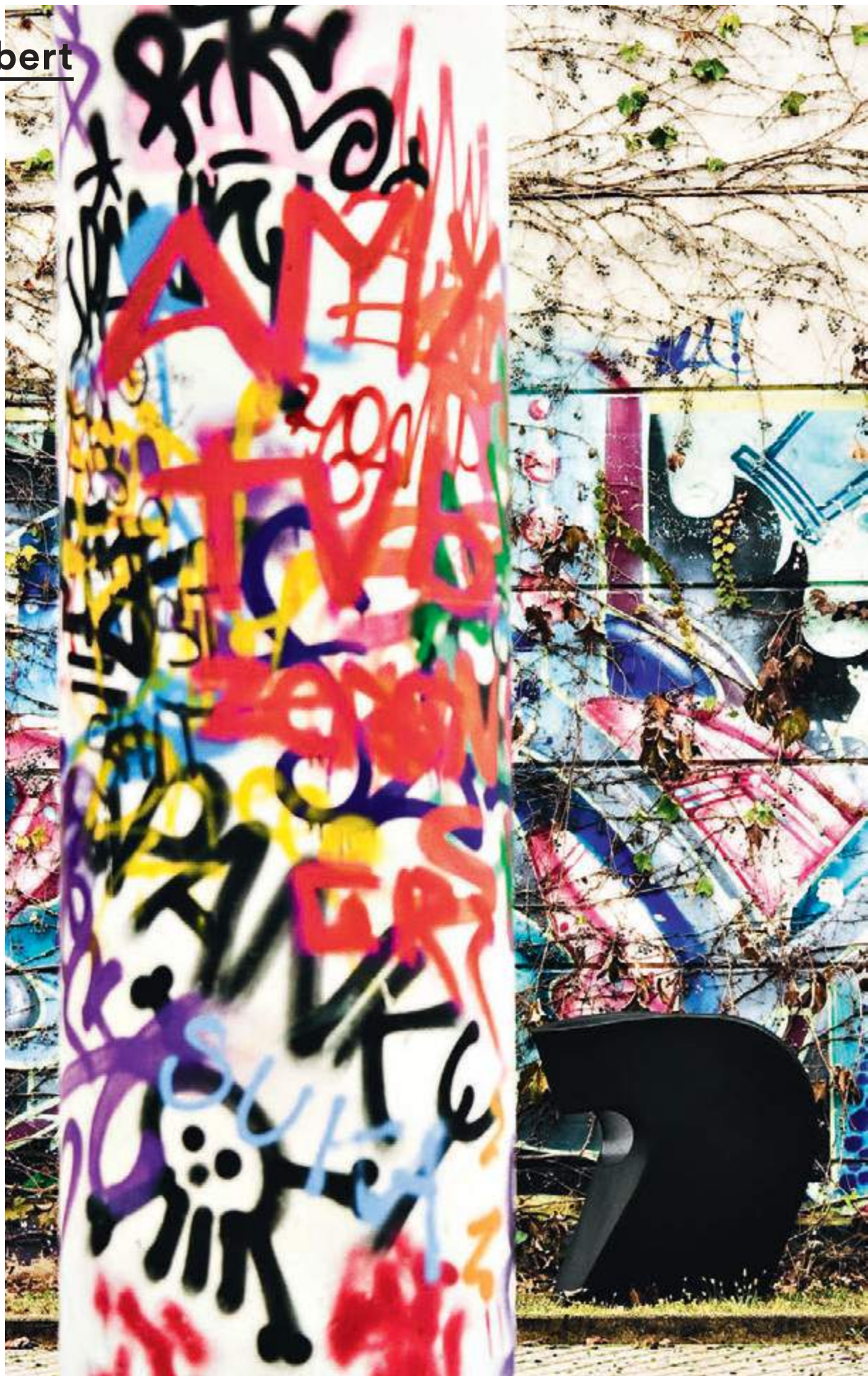



Little Albert designed for the town of Arad — 2000

Little Albert

Outdoor

Moroso vol 3/3

Little Albert design Ron Arad — 2000







O-Nest

Outdoor

Moroso vol 3/3

O-Nest design Tord Boontje — 2006



O-Nest

Moroso vol 3/3 Outdoor



O-Nest design Tord Boontje — 2006



The Big Easy

Moroso vol 3/3 Outdoor



The Big Easy design Ron Arad — 1991

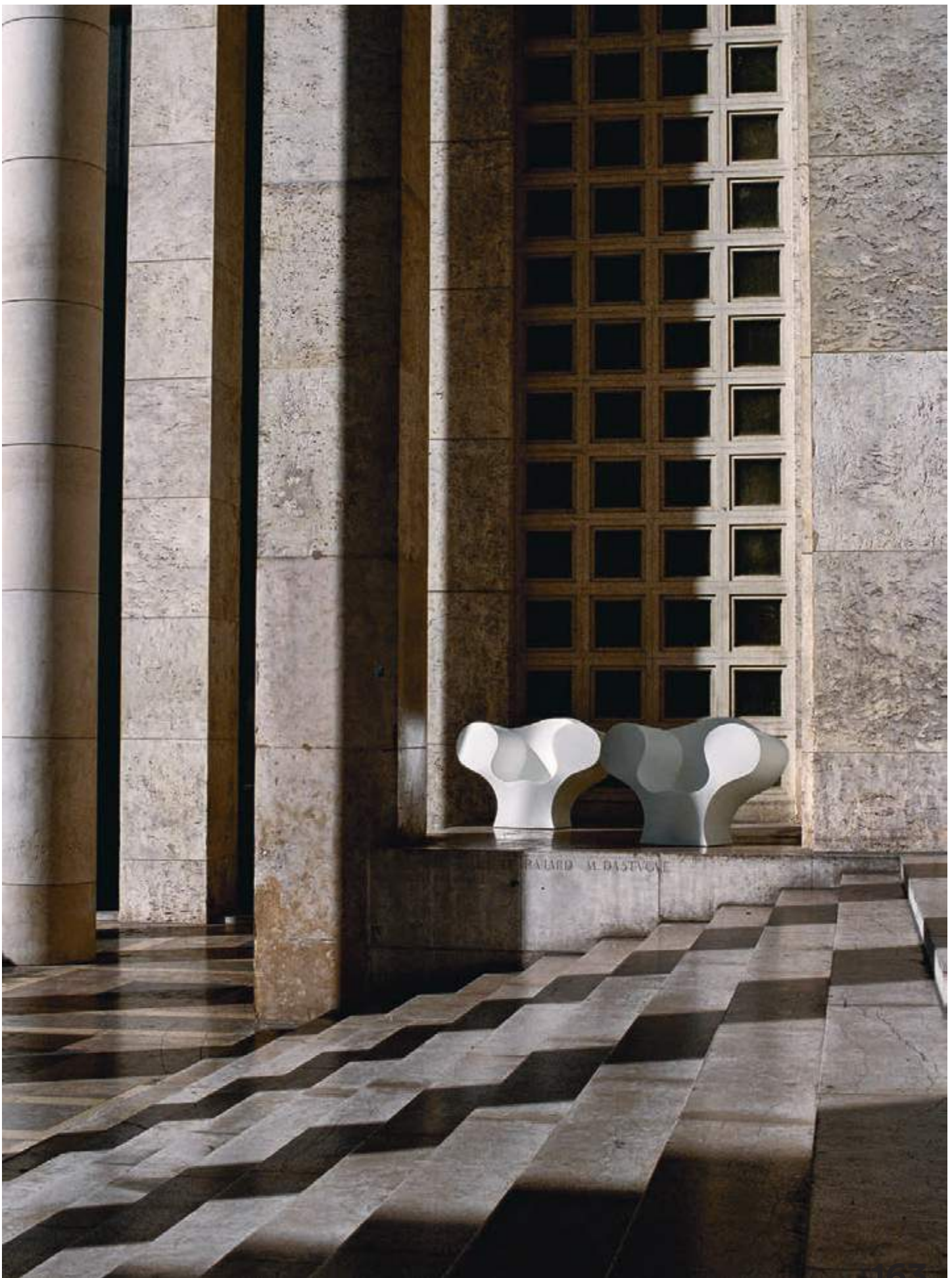



Tropicalia



Tropicalia design Patricia Urquiola — 2008



Tropicalia











Tropicalia

Moroso vol 3/3 Outdoor



Tropicalia design Patricia Urquiola — 2008



Tropicalia

Moroso vol 3/3 Outdoor



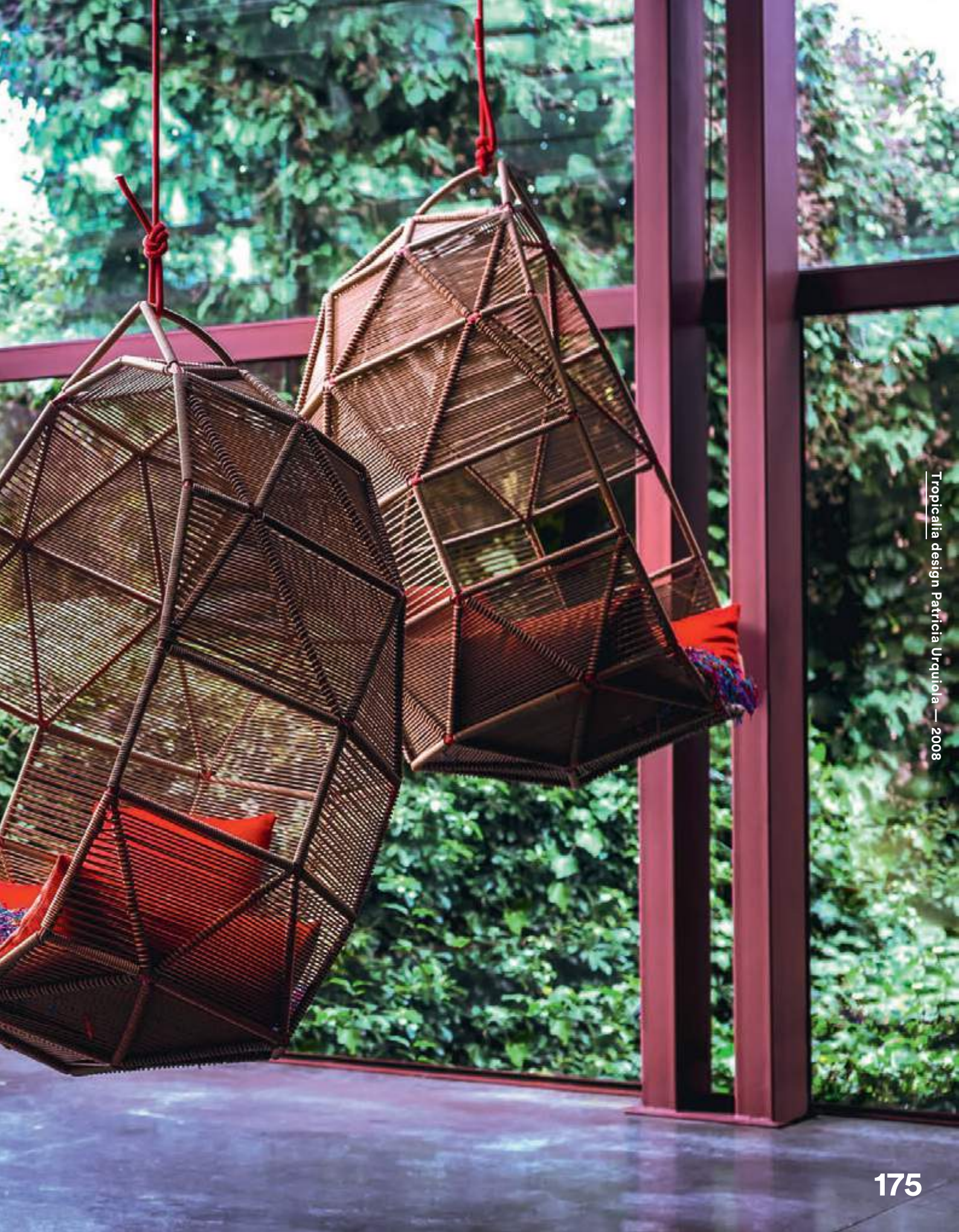

Tropicalia

Moroso vol 3/3 Outdoor

Tropicalia design Patricia Urquiola — 2008



Diatom

Moroso vol 3/3 Outdoor



Diatom design Ross Lovegrove — 2014







Diatom

Moroso vol 3/3 Outdoor



Diatom design Ross Lovegrove — 2014







Diatom design Ross Lovegrove — 2014







Moroso vol 3/3
Outdoor



Supernatural



Supernatural design Ross Lovegrove — 2005

Supernatural

Outdoor

Moroso vol 3/3





Supernatural design Ross Lovegrove — 2005

Ripple chair

Moroso vol 3/3 Outdoor



Ripple chair design Ron Arad — 2004

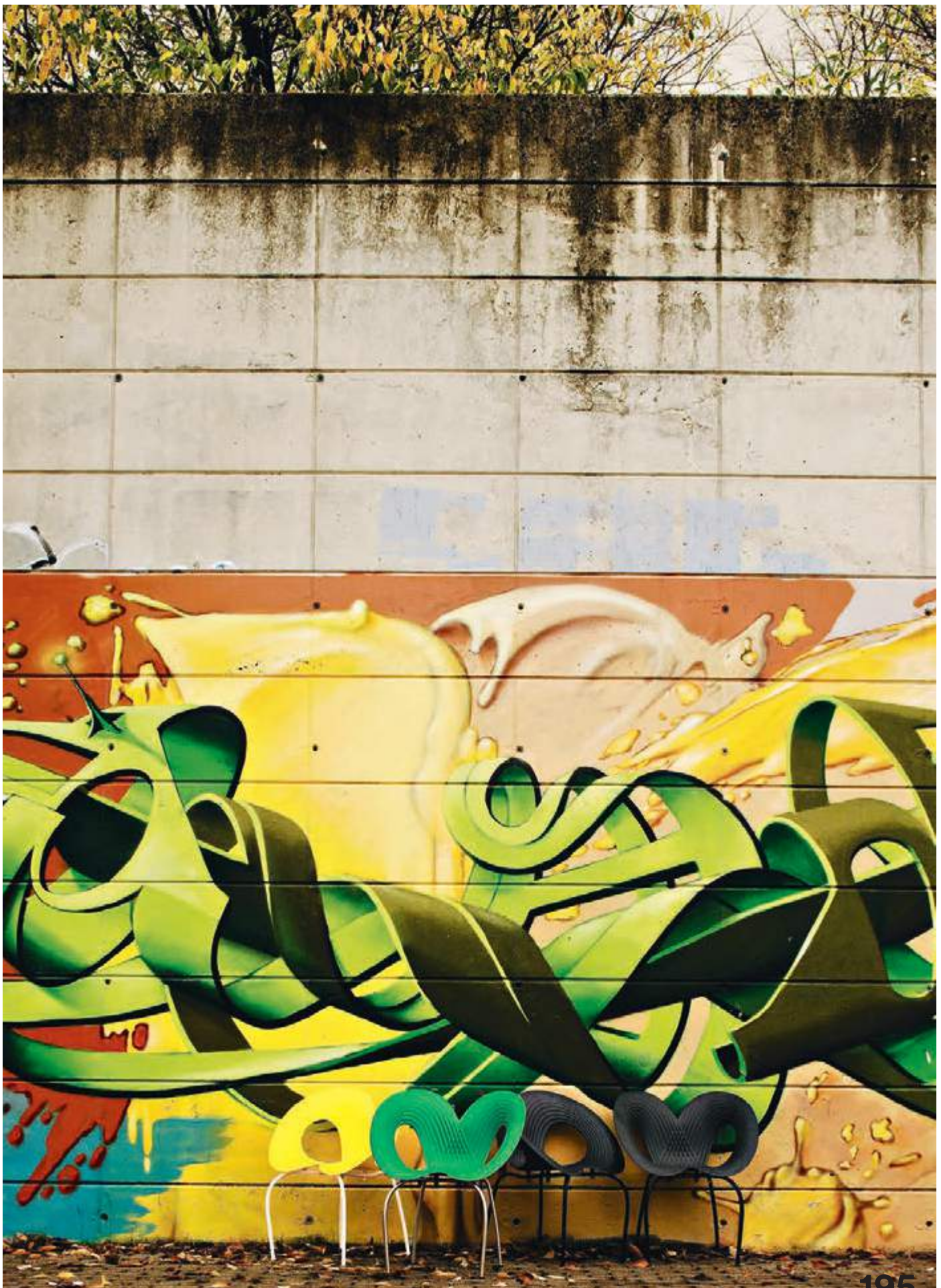

Ripple chair



Mojo vol 3/3
© Moor

Ripple chair design Ron Arad — 2004

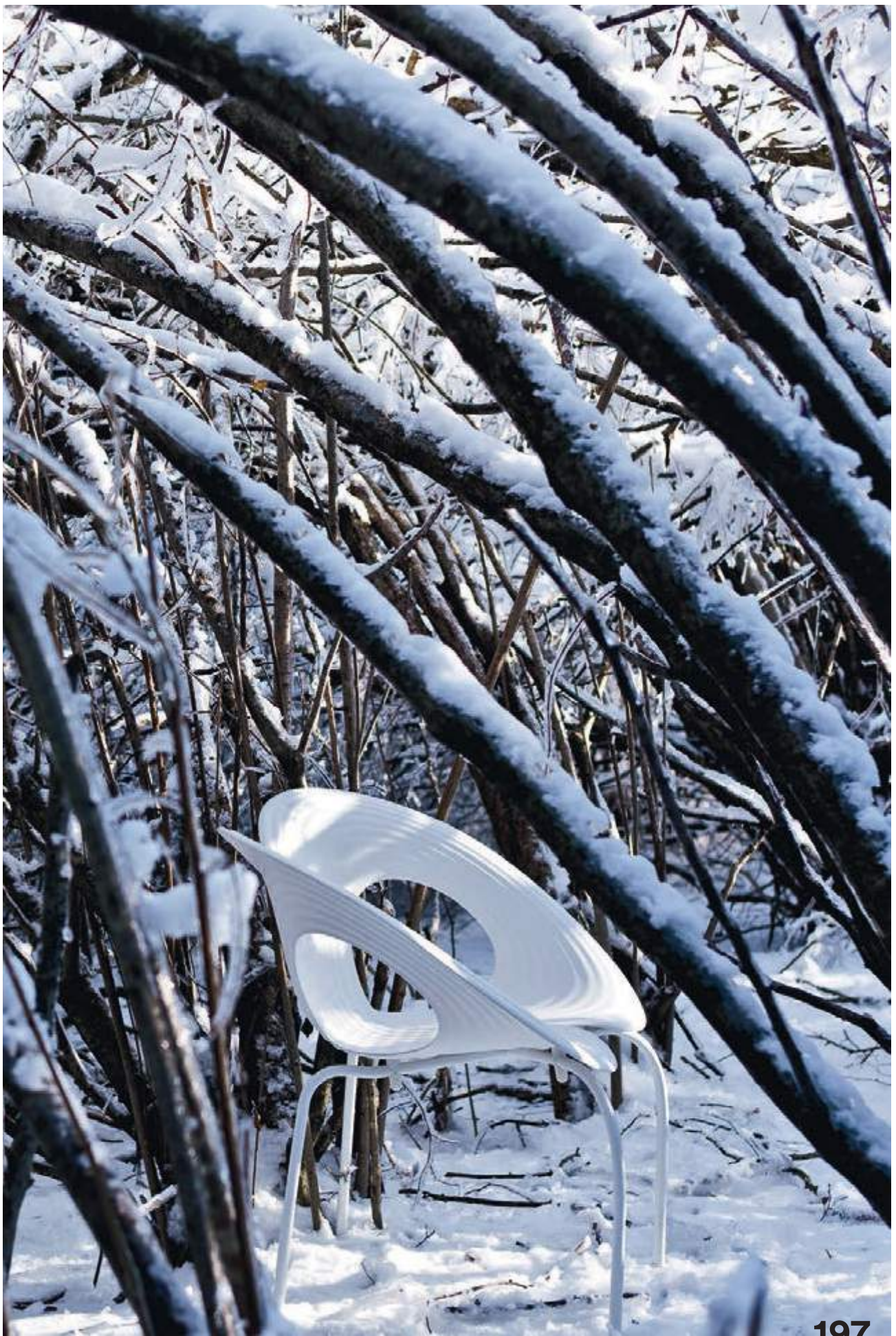

Ripple chair

Outdoor

Moroso vol 3/3

Ripple chair design Ron Arad — 2004



St. Mark

Outdoor

Moroso vol 3/3



St. Mark design Martino Gamper — 2015







Impossible Wood

Moroso vol 3/3 Outdoor

Impossible Wood design Nipa Doshi & Jonathan Levien — 2012





Impossible Wood



Impossible Wood design Nipa Doshi & Jonathan Levien — 2012













Oasis

Outdoor

Maroso vol 3/3

Oasis design Atelier Oi — 2013











Shitake

Moroso vol 3/3 Outdoor

Shitake design Marcel Wanders — 2007



Shitake

Moroso vol 3/3 Outdoor





Shitake design Marred Wanden — 2007

Moroso ~~Outdoor~~

~~M'Afrique~~

~~Forme plastique~~

Technical

info

Index



→ 102/103
228 Amaca



→ 104/105
230 Arco



→ 044 → 053
232 Banjooli



→ 057, 058/059, 064, 075
236 Baobab



→ 178 → 185
238 Diatom



→ 218, 219
240 Fjord H.



→ 122, 12
242 Gaal



→ 054 → 063
244 Husk



→ 064 → 071
246 Imba



→ 205, 206, 207
248 Impossible wood



→ 072/073, 074, 075
250 Iris, Ibisus



→ 096 → 101, 104/105
252 Jardin Suspendu



→ 151, 152/153, 155
254 Little Albert



→ 088/089
256 Madame Dakar



→ 144, 145, 146/147, 149
258 Moon



→ 194, 219
260 No-Waste



→ 076 → 083
262 O) < Chair



→ 156/157, 159, 160, 161
264 O-Nest



→ 208 → 217
266 Oasis



→ 194 → 199
270 Ripple chair



→ 107 → 121
272 Shadowy, Sunny



→ 221, 222/223
276 Shitake



→ 200, 201, 202, 203
278 St. Mark



→ 187 → 193
280 Supernatural



→ 162, 163
284 The Big Easy



→ 085, 086, 087
286 Toogou



→ 090, 091
288 Touti



→ 164 → 177
290 Tropicalia



→ 093, 094/095
294 Weavers bench

Design David Weeks — 2017



Amaca nasce dalla collaborazione tra gli artigiani senegalesi di Dakar, che lavorano al progetto M’Afrique, e David Weeks. La trama e l’ordito dell’intreccio uniti alla naturale lavorazione a spirale creano un effetto che può essere eseguito in varie combinazioni di colori.

Amaca is part of M’Afrique, a collaboration between artisans in Dakar, Senegal and David Weeks. The warp and weft of the weave combined with the spiral nature of the design create a pattern, and can be executed in colour combinations.

Day bed. Fatta interamente a mano a Dakar, in Senegal, da artigiani locali, questa collezione è costruita con cordini in polietilene – tradizionalmente utilizzati per realizzare reti da pesca – tessuti direttamente su struttura d’acciaio con trattamento antiruggine per uso interno/esterno.

Day bed. Handmade entirely in Dakar, Senegal by local artisans, this collection is constructed with a durable polyethylene cord – traditionally used to make fish nets – woven directly to the tubular steel frame with anti-rust treatment for indoor/outdoor use.

Code AM1

S95 S97

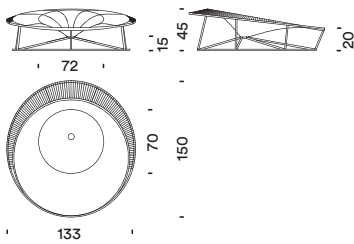

S96 S98

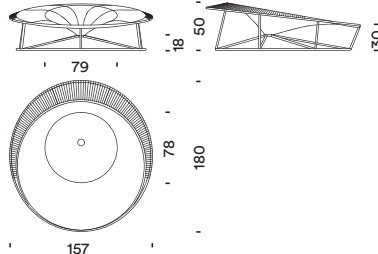

Single seats and accessories
→ vol. 2

Pattern colours



panama
04-panama
07-vert lagon
17-vert clair



gris
13-gris
11-oxyde
04-panama



oxyde
11-oxyde
02-rose
03-orange



noir
14-noir
13-gris
05-jane



silver
104-silver
114-bordeaux
107-beige



oxyde
111-orange
114-bordeaux
112-rose



noir
102-noir
106-canapa
109-yellow fluo



Design Martino Gamper — 2017



La famiglia di sedie Arco è stata progettata osservando la deformazione che subisce una linea sottoposta alla tensione della tessitura. Da questo concetto iniziale nascono raggi, curve, archi. Ciascuna delle superfici intrecciate ha colori in contrasto che enfatizzano le varie parti della sedia.

The Arco family of outdoor chairs is designed using simple curves and radiuses. While weaving, the frame is under tension, enforcing the visual language of the curves. Each of the woven surfaces is in contrasting colours to emphasise the different elements of the chair.

Poltrone e tavolini. Fatta interamente a mano a Dakar, in Senegal, da artigiani locali, questa collezione è costruita con cordini in polietilene – tradizionalmente utilizzati per realizzare reti da pesca – tessuti direttamente su struttura d'acciaio con trattamento antiruggine per uso interno/esterno.

Armchairs and low tables. Handmade entirely in Dakar, Senegal by local artisans, this collection is constructed of a durable polyethylene cord – traditionally used to make fish nets – woven directly to the tubular steel frame with anti-rust treatment for indoor/outdoor use.

Code ARO

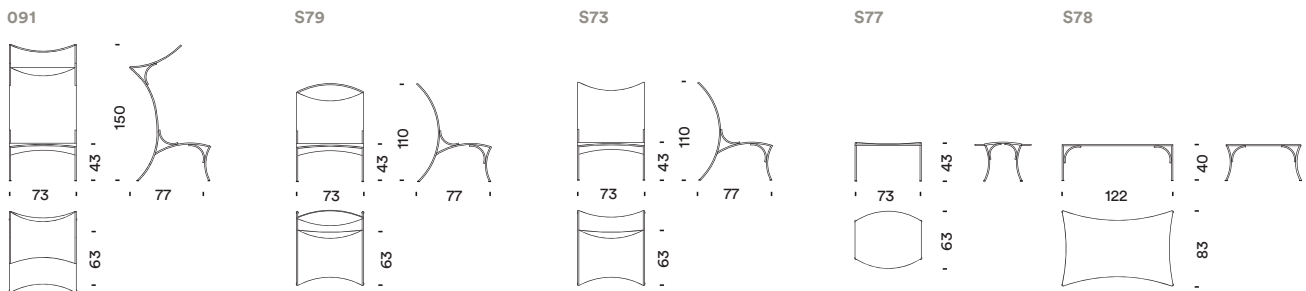

Single seats and accessories
→ vol. 2

Colours lounge chairs

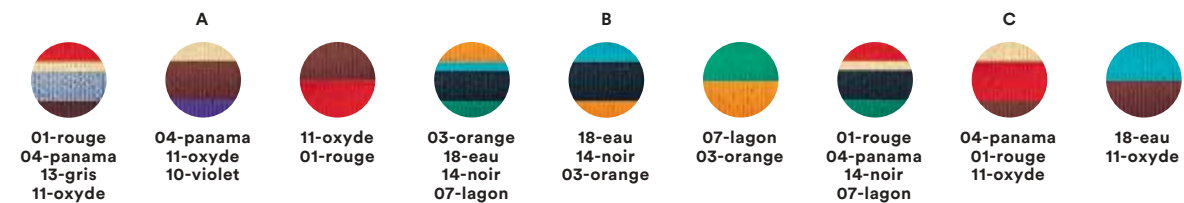

Pattern colours low tables

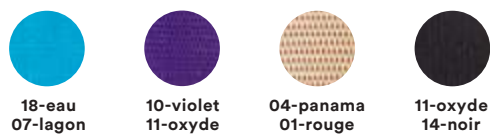



Banjooli

← pp. 044 → 053

Design Sebastian Herkner — 2014



Con forme ispirate al ballo di corteggiamento degli struzzi, prendendo in prestito i colori brillanti di uccelli tropicali, questa vivace collezione è progettata per radunare sedute e tavoli in quantità e liberamente distribuirle attorno a una piscina o in un terrazzo.

Poltrona, poltrona senza braccioli, divano, 4 tavoli bassi e 2 tavoli da bistrot. Fatta interamente a mano a Dakar, in Senegal, da artigiani locali, questa collezione è costruita con cordini in polietilene – tradizionalmente utilizzati per realizzare reti da pesca – tessuti direttamente su struttura d'acciaio con trattamento antiruggine per uso interno/esterno.

With shapes inspired by the courtship dance of ostriches, and borrowing the brilliant colours of tropical birds, this light-hearted collection of seating and tables is designed to gather in flocks outdoors by the pool or perched on a high-rise terrace.

Armchair, armless chair, settee, 4 low tables and 2 bistro tables. Handmade entirely in Dakar, Senegal by local artisans, this collection is constructed of a durable polyethylene cord – traditionally used to make fish nets – woven directly to the tubular steel frame with anti-rust treatment for indoor/outdoor use.

Code BJ0



Settee



Small armchair



Chair



Tables

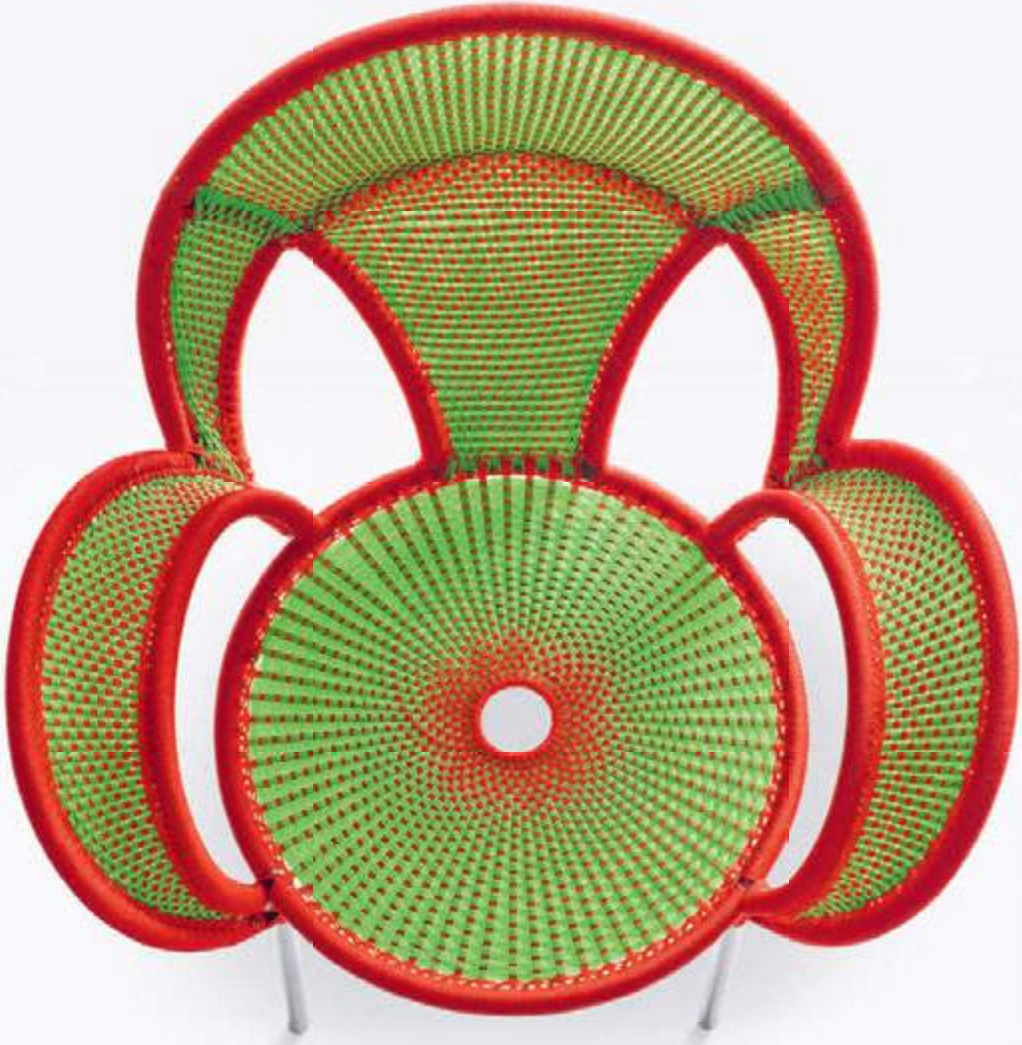

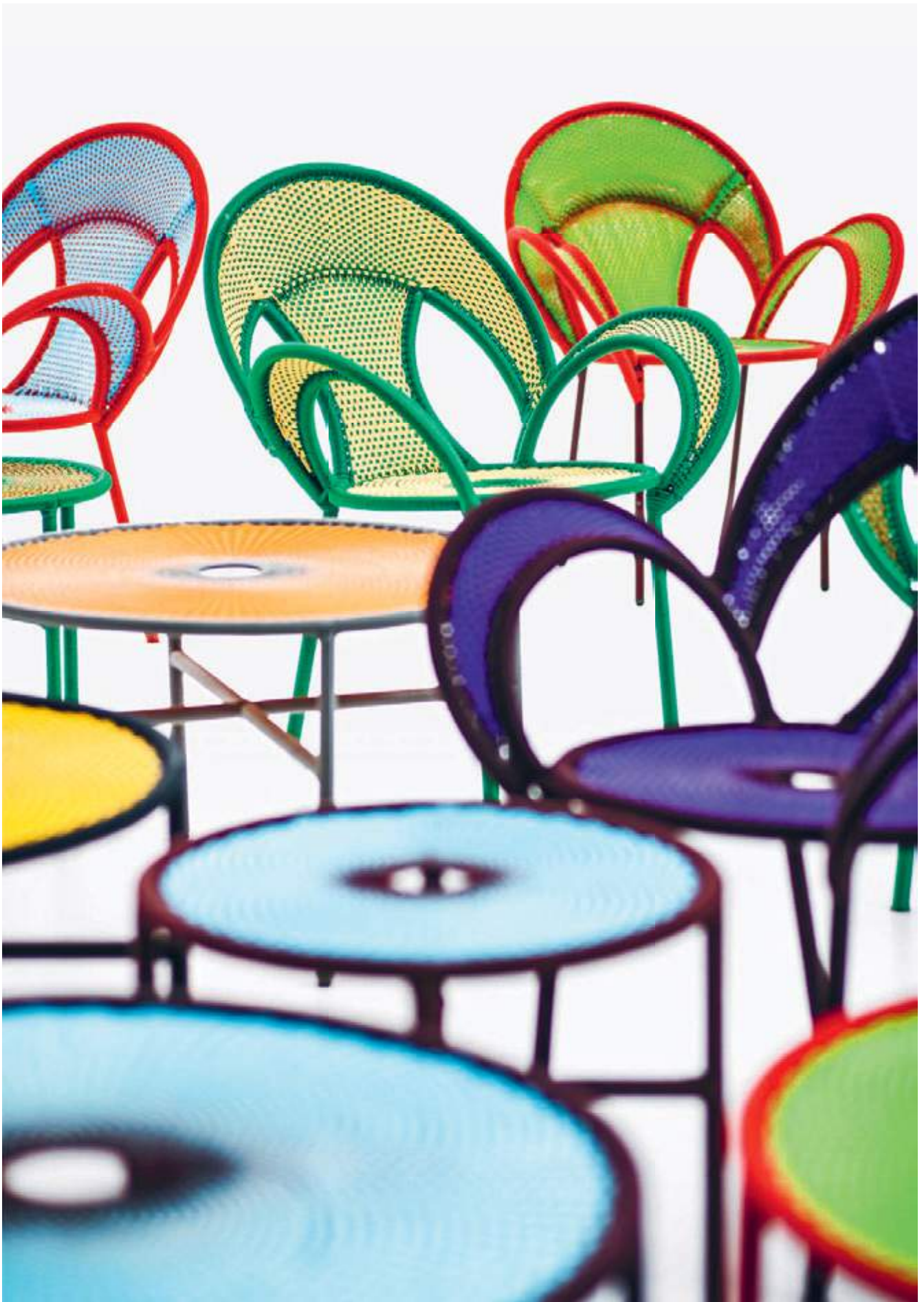

Code BJO

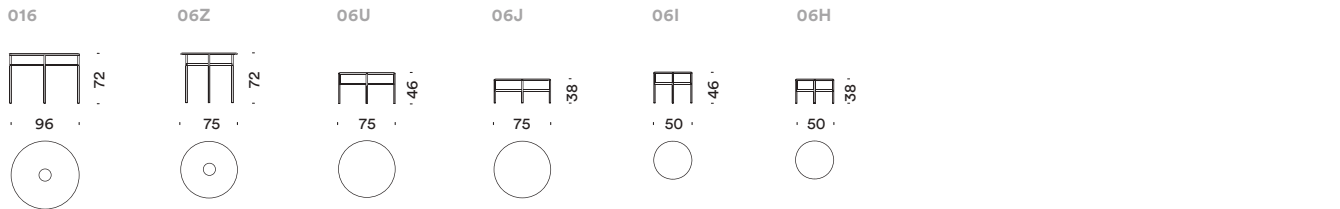
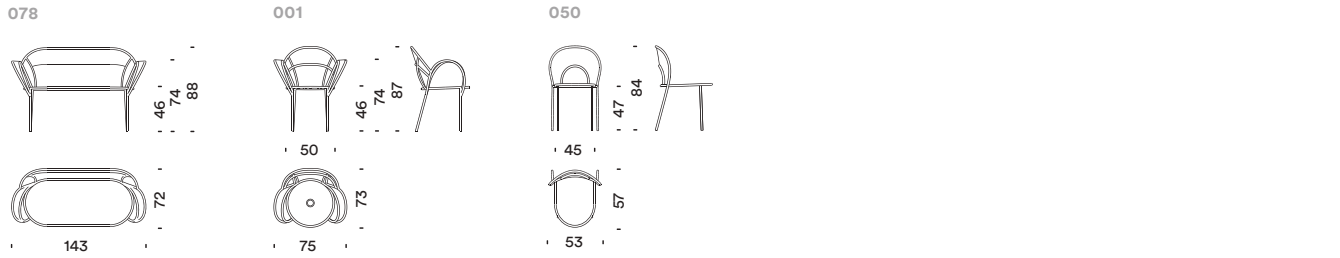

Outdoor — Technical info

Pattern colours

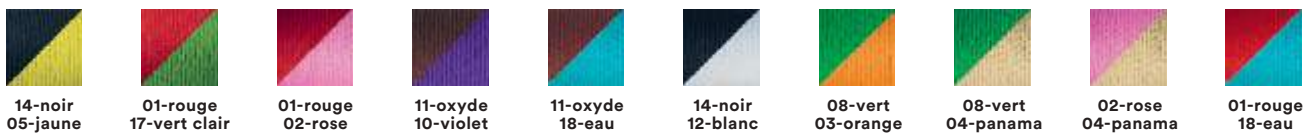

Baobab

Design Marc Thorpe — 2016

← pp. 057, 058/059, 064, 075



Baobab si ispira all'albero che si trova in tutto il continente africano. Un caratteristico tronco largo e una chioma larga e piatta.

Baobab is inspired by the iconic Baobab tree found throughout the African continent. A large trunk with a flat canopy of branches are its defining characteristics.

Pouf/poggiaiedi e due tavoli bassi. Fatta interamente a mano a Dakar, in Senegal, da artigiani locali, questa collezione è costruita con cordini in polietilene – tradizionalmente utilizzati per realizzare reti da pesca – tessuti direttamente su struttura d'acciaio con trattamento antiruggine per uso interno/esterno. Il tessuto del cuscino del pouf è un cotone con una lavorazione tie-dye fatta a mano in Senegal. I piani dei tavolini sono in MDF e sono verniciati con un composto a base di argilla o cemento. Consigliato per interni.

Stool and two low tables. Handmade entirely in Dakar, Senegal by local artisans, this collection is constructed of a durable polyethylene cord – traditionally used to make fish nets – woven directly to the tubular steel frame with anti-rust treatment for indoor/outdoor use. Footstool has a polyurethane foam cushion covered in African fabric to complement base. The fabric is a cotton manufactured by a tie-dye technique in Senegal. Table tops in MDF with three hand-applied layers of concrete or clay finish. For indoor use.

Code BA1

017

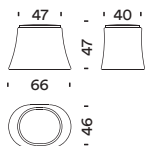

10DS

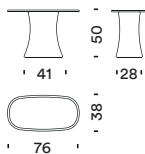

10DT

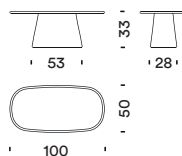

Single seats and accessories
→ vol. 2

Side tables: top tables and base pattern colours

Low table



top lava
14-noir
08-vert



top lava
14-noir
11-oxyde



top lava
14-noir
06-or



top terracotta
14-noir
11-oxyde



ochre
14-noir
06-or



top cement
12-blanc
13-gris



top chalk
12-blanc
13-gris



top lava
14-noir

Pattern colours pouf



14-noir
08-vert



14-noir
11-oxyde



14-noir
06-or



13-gris
12-blanc



Diatom

← pp. 178 → 185

Design Ross Lovegrove — 2016



Diatom prende la sua forma dal frustolo di una diatomea, primordiale organismo unicellulare dallo scheletro di silicio, diffuso in tutti gli ambienti acquatici. Una raffinata geometria ornamentale che esplora regole matematiche le quali dettano lo sviluppo vegetativo di un organismo vivente. La produzione adotta alta tecnologia del settore automobilistico; una lamiera in alluminio pressofuso assicura la massima leggerezza parimente le prestazioni dell'acciaio.

Diatom takes its shape from the frustule of a diatom, this primordial single-cell organism with silica skeletons found in water all over the world. Refined ornamental geometry in three-dimensions, a marvel of structure devised from exploring the rules of mathematics that dictate the vegetative development of living organisms. Production uses a technology developed for the automotive industry; die-cast aluminium sheeting ensures the lightest weight and while guaranteeing levels of performance and resistance equal to those of steel.

Poltroncine impilabili. Strutture in alluminio verniciato o anodizzato. Gambe in alluminio e sottopiedi in polietilene. Adatta per interno ed esterno. Impilabile verticalmente.

Stackable chair. Pressed aluminium seat/back with aluminium and steel legs, with a range of anodized and powder coat finishes. Stacks vertically.

Code DT0

01F-01P

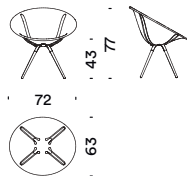

Single seats and accessories
→ vol. 2



Colours



white
RAL 9003



shell
NCS
S 3010-Y70R



papyrus grey
RAL 9018



lichen
NCS
S 3010-G60Y



stardust
NCS
S 3010-B



light yellow
Pantone 395



anodized
aluminium



copper brown
metallic



Fjord H.

← pp. 218, 219

Design Patricia Urquiola — 2002



Elogio dell'imperfetto: la perfezione in un frammento di conchiglia. Fjord, collezione disegnata nel 2002 da Patricia Urquiola per Moroso, trasforma un concetto astratto in un oggetto di design contemporaneo. Bellezza incompleta e allusiva, trova un valore organico nella simbiosi con l'oggetto rotto trovato sulla spiaggia, levigato dalle onde. Fjord rappresenta una forma iconica spezzata e ri-generata dal tempo e dall'acqua. L'influenza scandinava, evocata fin dal nome della collezione, è nella presenza in tutte le sedute di un taglio allungato, metafora delle insenature delle coste nordiche.

Sedia. Scocca in materiale plastico composito formato da tecnopolimeri stratificati di densità variabile. Basi a slitta in acciaio Inox.

Sistema modulare su barra: struttura portante in acciaio verniciato canna di fucile. Piedi in fusione di alluminio lucidato con tavolo in laminato HPL di colore bianco o nero opaco.

In praise of the imperfect. Perfection in a shell piece. Fjord, a seating collection which Patricia Urquiola designed for Moroso in 2002, turns an abstract concept into a modern design object. Its allusive, incomplete beauty has a natural value in its symbiosis with a broken object smoothed by the waves and tossed on the beach. Fjord displays an iconic shape split and regenerated by time and water. The Scandinavian influence – starting with the collection's name – the long cut featured on the seats and stools, a metaphor for the typical inlets of the Nordic coasts.

Chair. Seat/back is multilayer techno-polymer composite in varied densities. Sled base in tubular inox stainless steel.

Beam modular system: beam is tubular steel with gunmetal varnished finish, feet are polished aluminium. Table is matt white or matt black HPL.

Code FH0

105-106

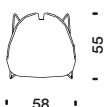

116-117-119-120

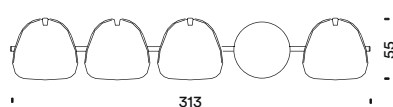
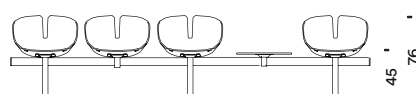

Single seats and accessories
→ vol. 2

Base colours



white chalk
RAL 9002



black
RAL 9005



stainless
steel

Shell colours



white
RAL 9003



white/black



Design Birsel+Seck — 2008



Ayşe Birsel dalla Turchia e Bibi Seck nato a Parigi da genitori senegalesi, hanno colto l'opportunità di realizzare idee vicine alle loro radici: Gaal, una versione di letto tradizionalmente in legno, realizzato con anelli di metallo e con le estremità che si stringono come le barche da pesca senegalesi.

Panca. Fatta interamente a mano a Dakar, in Senegal, da artigiani locali, costruita con anelli in d'acciaio trattato antiruggine per uso interno/esterno.

Ayşe Birsel, from Turkey, and Bibi Seck, born in Paris to Senegalese parents, enjoyed this opportunity to realize ideas close to their roots: Gaal, a version of traditional Senegalese wood beds, is made of metal circles, with narrowing ends, like Senegalese fishing boats.

Bench. Handmade entirely in Dakar, Senegal by local artisans, this bench is constructed in tubular steel frame with anti-rust treatment for indoor/outdoor use.

Code GA0

177

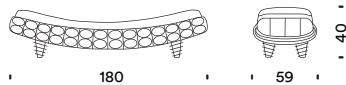

Frame colours



yellow
RAL 1012



traffic red
RAL 3020



green
RAL 6029

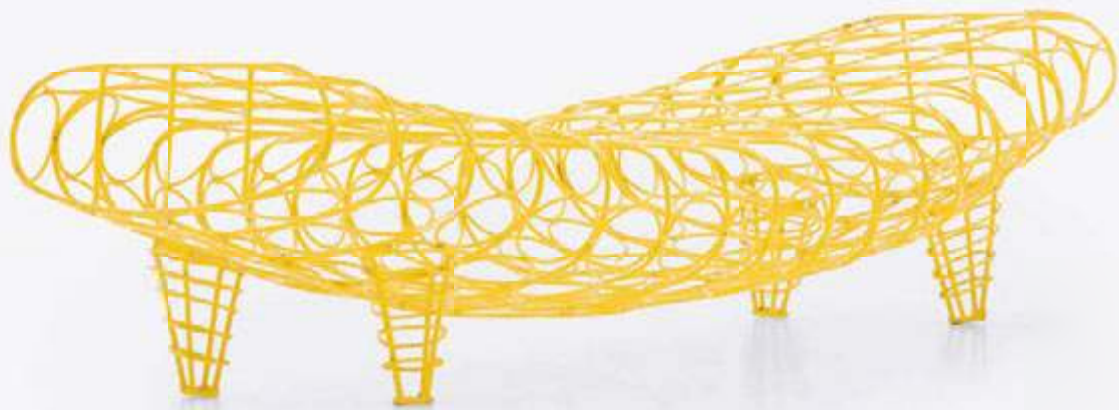

Husk

← pp. 054 → 063

Design Marc Thorpe — 2016



Fin dai tempi antichi, il mais è riconosciuto in tutto il mondo come alimento vitale e versatile. È l'ispirazione di Thorpe per questa sedia, una buccia di mais, che suggerisce un'avvolgente struttura protettiva leggermente chiusa. Minimalista, e con linee sobrie arricchite dalla qualità e raffinatezza dei materiali. È disponibile anche una versione imbottita.

Since ancient times, corn has been recognised across the world as a vital, versatile crop. It is Thorpe's inspiration for this chair, a corn husk, suggesting an enveloping, slightly enclosed, protective structure. Its minimalist and understated lines are enriched by the quality and sophistication of the materials. An upholstered version is also available.

Poltrona. Sedute in quattro diverse misure di schienale, basso per il pouf e, medio, alto o altissimo per le poltrone. Fatte interamente a mano a Dakar, in Senegal, da artigiani locali, costruite con anelli d'acciaio trattato antiruggine per uso interno/esterno.

Armchair. Seats in four backrest heights, small/stool, medium, large or extra large. Handmade entirely in Dakar, Senegal by local artisans, this bench is constructed in tubular steel frame with anti-rust treatment for indoor /outdoor use.

Code HU0

S92 XL

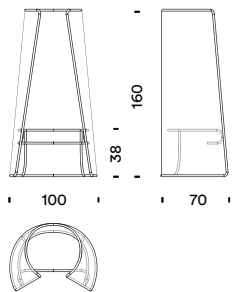

S91 L

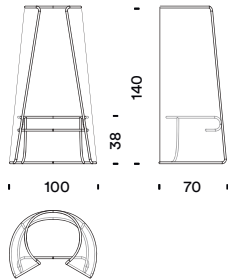

S90 M

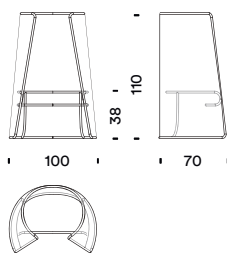

S93 S

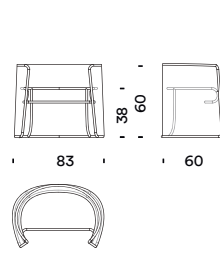

Single seats and accessories
→ vol. 2

Code HU0



Husk M

Husk XL

Husk L

Husk S

Pattern colours



01-rouge



17-vert clair



14-noir
06-or



06-or
05-jaune



Design Federica Capitani — 2016



L'origine di Imba deriva dalla combinazione giocosa di due anelli fluttuanti e intrecciati. La geometria dell'anello interno utilizza un motivo a trama chiusa per il sedile e schienale. Il cerchio esterno avvolge delicatamente lo schienale e ha un intreccio aperto per creare due ali al lato.

Imba's origin comes from the playful combination of two floating, intertwined hoops. The geometry of the inner loop uses a closed woven pattern for the seat and backrest. The outer loop gently wraps around the backrest and has an open weave to create two wings at the side.

Poltrona, chaise longue e poggiatesta. Fatti interamente a mano a Dakar, in Senegal, da artigiani locali, costruiti con anelli d'acciaio trattato antiruggine per uso interno/esterno.

Armchair, chaise longue and footstool. Handmade entirely in Dakar, Senegal by local artisans, this bench is constructed in tubular steel frame with anti-rust treatment for indoor/outdoor use.

Code IM0

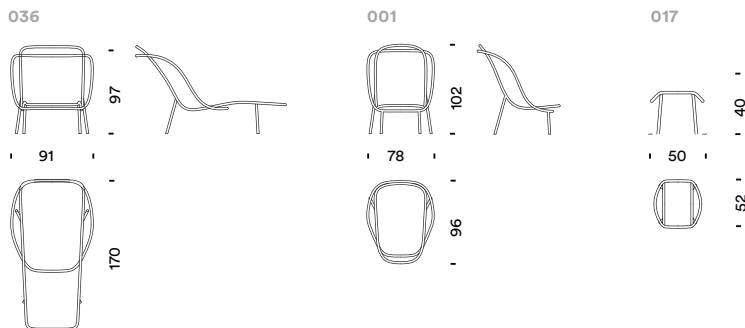

Code IM0



Pattern colours

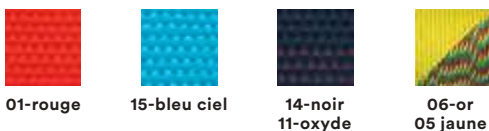



Impossible wood

← pp. 205, 206, 207

Design Nipa Doshi & Jonathan Levien — 2012



Ingannando Möbius, una prospettiva ingannevole e un nuovo materiale rende credibile la curvatura del nastro, impossibile per il legno. Impossible wood ha avuto origine come progetto incentrato sull'utilizzo di un legno plastico. È chiaramente visibile sui braccioli che si avvolgono elegantemente sulla schiena e la seduta come un fiocco di balse.

Chairs. Scocca in polipropilene e basamento in tubo d'acciaio verniciato, cromato o inox AISI 304 adatto per l'esterno. Sottopiedi in polipropilene. Impossible wood è impilabile.

Cheating Möbius sense-defying perspective, a new material makes a new material makes the curves possible, impossible wood. Impossible Wood began as a project using a plastic wood material. For this version, the wood reference is clearly preserved, with arms wrapping as gracefully as a ribbon of veneer from back to front.

Chairs. Shell is moulded polypropylene; 4-leg base is tubular steel with varnished finish, chrome or stainless steel AISI 304 suitable for outdoor use; polypropylene glides. Impossible Wood is stackable.

Code IWO

OFU-OFS-OFT

OFV-OFR-OFX

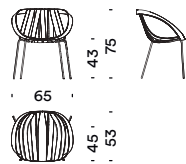
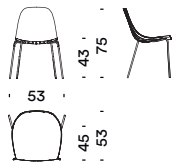

Shell colours



white
RAL 9010



blush
NCS
S 3010-Y70R



indian pink
RAL 3014



oxidored
RAL 3009



ocean blue
RAL 5020



forest green
Pantone 6005



clay gray
RAL 7035



black
RAL 9005

Leg colours



white chalk
RAL 9002



oxidored
RAL 3009



chromed
steel



black chromed
steel



stainless
steel



Iris, Ibiscus

← pp. 072/073, 074, 075

Design Dominique Pétot — 2009



Queste sedie presentano volumi distesi e curve che ricordano forme animali e vegetali. Le loro figure esuberanti richiamano sedute sontuose dell'area coloniale britannica. La tessitura di alta qualità di abili artigiani senegalesi dà profondità agli intrecci della collezione, dando l'impressione di un tessuto che, nei braccioli, sembra fluttuare nel vento.

Sedie. Fatte interamente a mano a Dakar, in Senegal, da artigiani locali, questa collezione è costruita con cordini in polietilene – tradizionalmente utilizzati per realizzare reti da pesca – tessuti direttamente su struttura d'acciaio con trattamento antiruggine per uso interno/esterno.

These chairs feature outstretched volumes and curves reminiscent of plant and animal figures. Their exuberant shapes bring to mind sumptuous seating of the British colonial area. High-quality weaving by skilled Senegalese craftsmen give depth to the collection's surfaces, giving the impression of a fabric that, in the armrests, seems to sway with the wind.

***Chairs.** Handmade entirely in Dakar, Senegal by local artisans, this collection is constructed with a durable polyethylene cord – traditionally used to make fish nets – woven directly to the tubular steel frame with anti-rust treatment for indoor/outdoor use.*

Code IBO

001

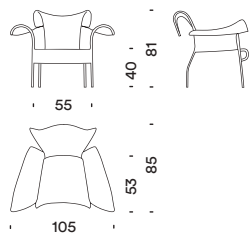

050

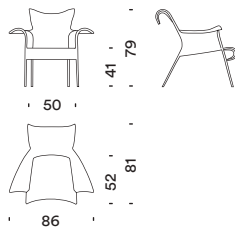

Pattern colours



01-rouge
12-blanc
14-noir



12-blanc
14-noir
01-rouge



11-oxylde
14-noir
03-orange



Jardin Suspendu

← pp. 096 → 101, 104/105

Design Concetta Giannangeli — 2016



Questi cestini colorati sprigionano energia e allegria. Progettati per contenere vasi e vasetti di ogni tipo, i cestini colorano ogni angolo in cui si trovano, al chiuso o all'aperto.

These colourful baskets radiate a cheerful energy. Designed to hold plant pots or vases, these baskets brighten every corner they're in, whether indoors or outside.

Cestini. Fatta interamente a mano a Dakar, in Senegal, da artigiani locali, questa collezione è costruita con cordini in polietilene – tradizionalmente utilizzati per realizzare reti da pesca – tessuti direttamente su struttura d'acciaio con trattamento antiruggine per uso interno /esterno.

Baskets. Handmade entirely in Dakar, Senegal by local artisans, this collection is constructed of a durable polyethylene cord – traditionally used to make fish nets – woven directly to the tubular steel frame with anti-rust treatment for indoor/outdoor use.

Code JS0

S85

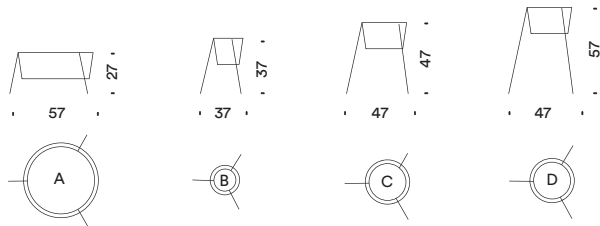

Code JS0

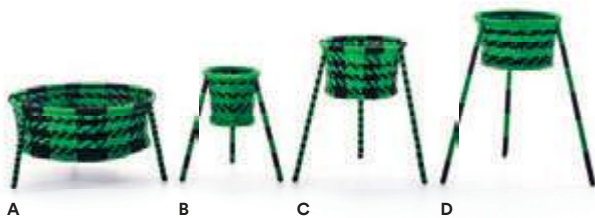

Pattern colours



box 1
05-jaune
11-oxyde



box 2
08-vert
14-noir



box 3
03-orange
11-oxyde
02-rose



box 4
12-white
14-noir
15-bleu ciel
03-orange



box 5
01-rouge
05-jaune
03-oxyde
11-oxyde
02-rose



box 6
01-rouge
02-rose
08-vert



Little Albert

← pp. 151, 152/153, 155

Design Ron Arad — 2000



Pare che escano dalla punta di una matita che non si è mai staccata dal foglio le forme che si sono evolute passando dal grande divano fino alla piccola poltrona. Le forme sono curve e armoniose e cambiano con naturalezza dal grande divano oversize fino alla poltrona e poltroncina. La collezione è così chiamata in omaggio al celebre museo di Londra dove, nel 2000, è stata realizzata una importante mostra antologica del lavoro Ron Arad.

Poltroncina. Polietilene tinto in massa riciclabile al 100% ottenuto mediante stampaggio rotazionale. Resistente all'acqua e alla luce, adatto per un uso outdoor.

Shapes which seem to have been drawn without the pencil ever leaving the paper, evolving from the large sofa, into the little armchair. The upholstered lounge series "Victoria and Albert" is distinguished by its extravagant curves in chairs and sofas ranging from the small scale to the over-scaled flourish of its signature sofa. The collection is named in homage to the London museum where an important anthology of Ron Arad's works was exhibited (2000).

Small armchair. Rotationally-moulded 100% recyclable polyethylene with integral colour. Waterproof and fade-resistant, suitable for outdoor use.

Code VA0

042

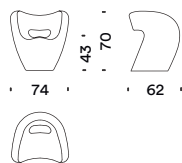

Single seats and accessories
→ vol. 2

Polypropylene colours



translucent
white



white chalk
RAL 9002



traffic red
RAL 3002



black
RAL 9005



sand
NCS
S 3010-Y70R



sky
Pantone 441



ocean blue
RAL 5020



Madame Dakar

← pp. 088/089

Design Birsel+Seck — 2009



Ayse Birsel dalla Turchia e Bibi Seck nato a Parigi da genitori senegalesi, hanno colto l'opportunità di realizzare idee vicine alle loro radici: Madame Dakar, l'impersonificazione di una donna bella e monumentale.

Divanetto. Fatta interamente a mano a Dakar, in Senegal, da artigiani locali, questa collezione è costruita con cordini in polietilene – tradizionalmente utilizzati per realizzare reti da pesca – tessuti direttamente su struttura d'acciaio con trattamento antiruggine per uso interno/esterno.

Ayse Birsel, from Turkey, and Bibi Seck, born in Paris to Senegalese parents, enjoyed this opportunity to realize ideas close to their roots: Madame Dakar, an impersonation of a beautiful and monumental woman.

Settee. Handmade entirely in Dakar, Senegal by local artisans, this collection is constructed with a durable polyethylene cord – traditionally used to make fish nets – woven directly to the tubular steel frame with anti-rust treatment for indoor/outdoor use.

Code MA0

001

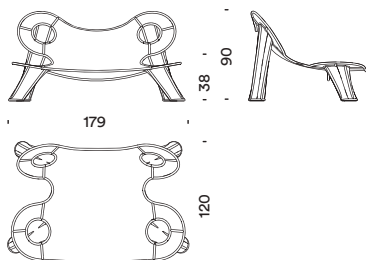

Pattern colours



05-jaune
11-oxyde
03-orange



Moon

← pp. 144, 145, 146/147, 149

Design Tokujin Yoshioka — 2010



Ogni ombra parla della luce.

Combinando perfezionismo e semplicità estetica in un equilibrio armonioso, la superficie della Moon assorbe e diffonde la luce in un modo che evoca le eteree e subliminali luci e ombre della luna. Le verniciature metalliche cambiano l'aspetto della sedia in una varietà di finiture.

Poltroncina. In polietilene tinto in massa riciclabile al 100% ottenuto tramite stampaggio rotazionale. Disponibile in una gamma di colori integrali oppure con vernice metallizzata. È adatta all'uso indoor/outdoor. La versione metallizzata è solo per indoor.

All shadows communicate with light.

By combining aesthetic simplicity and perfectionism into a harmonious equilibrium this armchair's surface is able to absorb and emanate light in such a way that mimics the ethereal and subtle light and shadows of the very Moon.

Small Armchair. 100% recyclable rotationally-molded polyethylene in a range of integral colours, or in a range of metallic colours. Polyethylene version can be used indoors and outdoors, and is weather-proof and fade resistant. Lacquered versions are not suitable for outdoor use.

Code MUO

042-361

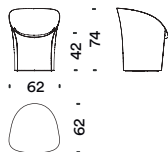

Single seats and accessories
→ vol. 2

Polyethylene colours



translucent white



agata grey
RAL 7038



ocean blu
RAL 5020



sulfur yellow
RAL 1016

Metallic colours



silver



titanium



copper



black iron



gold



bronze



No-Waste

← pp. 194, 219

Design Ron Arad — 2004



Da un solo pezzo di metallo nascono il piano, le gambe e le traverse. Tavolo progettato in modo da ottenere tutte le sue parti senza alcuno scarto di lavorazione, da un unico foglio di alluminio alveolare ultraleggero o da un foglio di ferro solido e pesante.

Tavolo. Disponibile con piano in alluminio ultraleggero bordato nero per uso esterno; con piano in alluminio ultraleggero impiallacciato Alpi® per uso interno; in lamiera di acciaio naturale verniciato; in lamiera d'acciaio verniciato bronzo o bianco.

No-waste, the top, legs and crossbars are formed from a single piece of metal. Table designed so all parts are obtained from a single sheet of ultralight aluminium honeycomb or iron with protective wax without producing any waste.

Table. Ultralight aluminium black edging for outdoor use; ultralight aluminium Alpi® veneered for indoor; natural painted steel sheet; sheet steel powder coated bronze or white.

Code NWO

016-06J

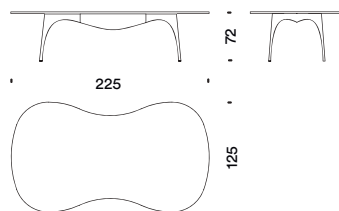

Single seats and accessories
→ vol. 2

Colours



aluminium
anodized



traffic white
RAL 9003



copper brown
metallic



black steel
matt finish



O)< Chair

← pp. 076 → 083

Design Tord Boontje — 2016



«L'idea per O)< Chair nasce da un acchiappasogni che mia figlia Evie ha fatto per il mio compleanno. Mi sono piaciuti i disegni e la trama e la possibilità di realizzarli in un modo così semplice. Mi ha fatto ricordare dell'esperienza avuta in Senegal: la possibilità di intrecciare a mano su di una struttura. Ho immaginato il cerchio come uno schienale molto largo che ti circonda, come un'aureola quando ti ci appoggi». –Tord Boontje

Poltrona. Fatta interamente a mano a Dakar ,in Senegal, da artigiani locali, questa collezione è costruita con cordini in polietilene – tradizionalmente utilizzati per realizzare reti da pesca – tessuti direttamente su struttura d'acciaio con trattamento antiruggine per uso interno/ esterno.

«The idea for the O)< Chair came from a dream-catcher that my daughter Evie had made for my birthday. I liked the pattern and that it could be made with such simple means. It reminded me of the possibilities we have in Senegal: to weave by hand on a simple frame. I imagined the circle becoming a very large backrest, which would surround you like a halo when you sit against it». –Tord Boontje

Chair. Handmade entirely in Dakar, Senegal by local artisans, this collection is constructed of a durable polyethylene cord – traditionally used to make fish nets – woven directly to the tubular steel frame with anti-rust treatment for indoor/outdoor use. On levelling glides.

Code OC0

050

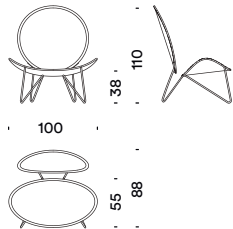

Pattern colours



green
08-vert
07-vert lagon
17-vert clair
15-bleu ciel



orange
03-orange
01-rouge
05-jaune



red
01-rouge
10-violet
03-orange



O-Nest

Design Tord Boontje — 2006

← pp. 156/157, 159, 160, 161



Questa sedia a forma di uovo è avvolta da una superficie in bassorilievo con fantasie floreali. I fori ai lati fungono da maniglia per alzare la sedia e, nel caso dovesse essere posta all'esterno, danno modo all'acqua piovana di scolare. La forma plastica, flessibile di natura, rende questa seduta adatta a luoghi pubblici, giardini, terrazzi e bar.

Poltroncina. Polipropilene riciclabile tinto in massa ottenuto mediante stampaggio rotazionale; resistente alla luce e all'acqua, adatto per uso esterno.

This egg-shaped chair has a surface swirling with fantasy florals in bas-relief, inviting touch and use. Practical details include portholes at seat level that prove handy grips to use for moving the chair — and, when Nest is outdoors in the rain, the portholes allow water run-off. The naturally malleable plastic provides a comfortable seat for public spaces, gardens, terraces and cafes.

Armchair for indoor/outdoor use. Rotationally molded, polyethylene offered in a range of integral colours, weather and fade-resistant.

Code NNO

042

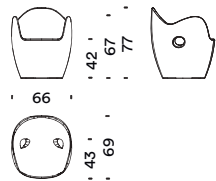

Colours



RAL 9010
magnolia



Pantone 396
cedrus



RAL 2009
red dahlia



RAL 3004
amaranth



RAL 9004
black ivy



Design Atelier Oi — 2013



Oasis trae ispirazione dagli arabeschi raffigurati nell'arte mediorientale e nei copricapi tradizionali degli uomini keffi yeh e riporta in grande scala quest'atmosfera esotica e finemente dettagliata. Da usare singolarmente come poltrone o da unire per creare un divano. La collezione include un tavolo e una sedia, uno sgabello e un gruppo di tavolini in metallo.

Elementi modulari per composizioni, poltrone, pouf e sgabelli bar. Struttura in alluminio estruso e supporti integrati in poliammide, struttura seduta in rete poliestere. Piedi in alluminio anodizzato. Schienali e braccioli in tubo di alluminio verniciato. I cuscini della seduta sono in poliuretano espanso idrorepellente rivestito in tessuto adatto per uso esterno. I cuscini dello schienale (consigliati) sono in fibra poliestere per uso esterno. La collezione Oasis è sfoderabile.

Tavoli, sedia e sgabelli. Piani in lamiera di alluminio perforata e verniciata. Tubo in alluminio verniciato. Sottopiedi in termoplastica.

Oasis takes its inspiration from the arabesques depicted in Middle Eastern art and the traditional keffi yeh men's headdress and brings this intricately detailed and exotic mood into large focus. Use them as single chairs or combine two or more chairs to create a sofa. The series also includes a table and chair, barstool as well as a group of low metal tables.

Modular elements for compositions, armchairs, stools and bar stools. Elements with frame in extruded aluminium and integrated poly-amide supports, seat in polyester mesh. Feet in anodized aluminium. Armrest in powder coated tubular aluminium for outdoor use. Seat cushions are water-repellent polyurethane foam covered with outdoor fabric. Back pillows (recommended) are in polyester fibre fill suitable for outdoor use. Oasis collection covers are removable.

Tables, chair and stools. Varnished for aluminium outdoor use. Table tops are perforated sheet metal; bases are tubular aluminium; on thermoplastic glides.

Code OA0



Modular elements



Armchair

Pouf



Chair

Barstool



Tables

Colours



white
RAL 9003



shell
NCS
S 3010-Y70R



lichen
NCS
S 3010-G60Y



stardust
NCS
S 3010-B



oxidored
RAL 3009



ink
Pantone 5463





Code OA0

07B - 07S

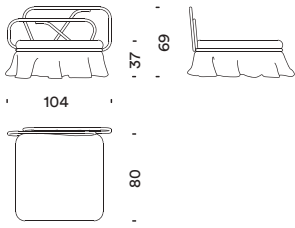

07E - 07Y

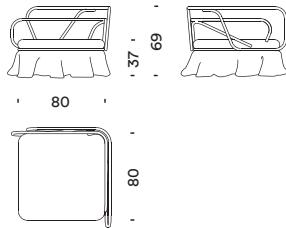

07D - 07W

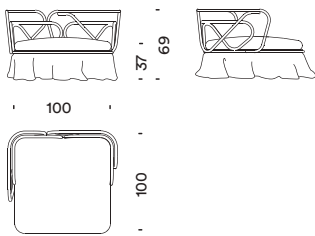

07C - 07T

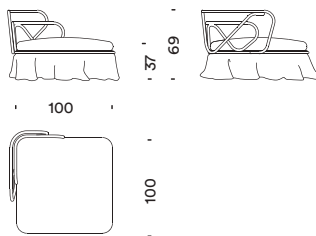

07P - 07Z

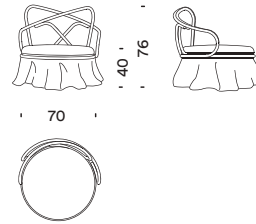

Ottoman

Table

09E - 09C

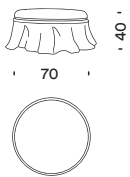

09D - 09B

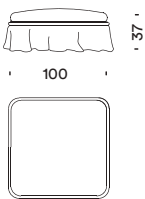

07F

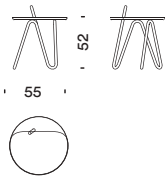

07G

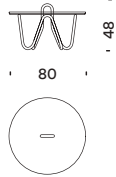

07H

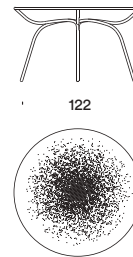

06B

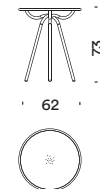

Chair

Barstool

050

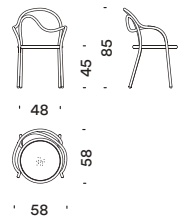

020

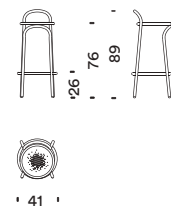

Ripple chair

← pp. 194 → 199

Design Ron Arad — 2005



Questa sedia di Ron Arad è allo stesso tempo semplice e complessa, come le infinite increspature sulla superficie di un lago. Versatile e adatta a ogni situazione, pesa solo 5.4 kg e la si muove facilmente tra interni ed esterni, per luoghi pubblici, hospitality.

Poltroncina. Scocca in polipropilene e basamento in tubo di acciaio verniciato a polveri, cromato o in acciaio inox 316L adatto per l'esterno. Sottopiedi in polietilene. La sedia è impilabile fino a 5 unità.

Ron Arad's chair is both simple and complex at once, like the infinite ripples over the surface of a pond. A versatile, all-purpose chair, at only 12 lbs(5.4kg), Ripple moves easily in and out of doors, for public spaces, hospitality and more.

Stacking chair. Polypropylene shell is available in black or white integral color. Base is tubular stainless steel 316L, or powder coat finish; on glides. Stacks up to 5 high.

Code RC0

050-0FT

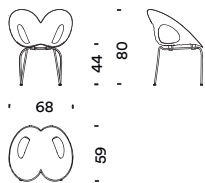

Shell colours



pure white
RAL 9010



black
RAL 9005

Leg colours



white chalk
RAL 9002



black
RAL 9005



steel
chrome



Shadowy, Sunny

← pp. 107 → 121

Design Tord Boontje — 2016



Shadowy e Sunny di Tord Boontje sono possedute da una grazia fuori misura. Sono fatte da artigiani locali a Dakar, in Senegal. Il design esuberante di Boontje alleato con un artigianato di lunga data danno vita a una coppia meravigliosamente esotica ed evocativa.

Poltrona e chaise longue con baldacchino, sedia con ricciolo e poggiatesta. Fatta interamente a mano a Dakar, in Senegal, da artigiani locali, questa collezione è costruita con cordini in polietilene – tradizionalmente utilizzati per realizzare reti da pesca – tessuti direttamente su struttura d'acciaio con trattamento antiruggine per uso interno/esterno.

Tord Boontje's Shadowy and Sunny are enveloped by an immeasurable grace. All are made by local craftspeople in Dakar, Senegal. Boontje's exuberant design paired with a long-established craft result in a wonderfully exotic and evocative pair.

Armchair and chaise longues with high back/canopy, and chair and footstool. Handmade entirely in Dakar, Senegal by local artisans, this collection is constructed of a durable polyethylene cord – traditionally used to make fish nets – woven directly to the tubular steel frame with anti-rust treatment for indoor/outdoor use.

Code SW0



Chair
Sunny

Pouf
Sunny

Armchair
Shadowy

Chaise longue
Shadowy





Shadowy, Sunny

Code SWO

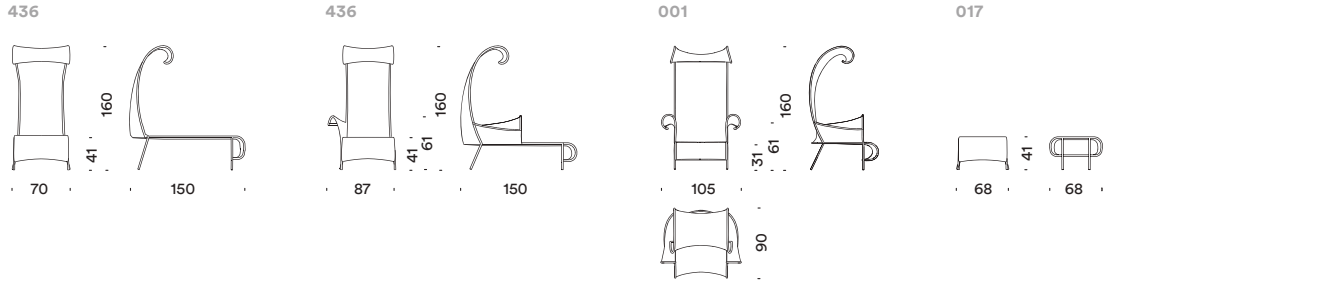

050

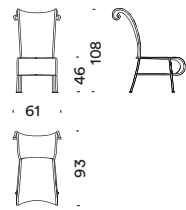

Outdoor — Technical info

Pattern colours



multired
01-rouge
03-orange
05-jaune
14-noir



multigreen
08-vert
17-vert clair
16-bleu



supercolour
01-rouge
06-or
14-noir
16-bleu



black / white
12-blanc
14-noir



tweed
11-oxyde
09-turquoise



tartan
11-oxyde
09-turquoise

Monocolours



01-rouge



02-rose



03-orange



04-panama



05-jaune



06-or



07-vert lagon



08-vert



17-vert clair



11-oxyde



12-blanc



13-gris



14-noir



10-violet



16-bleu



15-bleu ciel



09-turquoise



18-eau

Shitake

← pp. 221, 222/223

Design Marcel Wanders — 2007



Fungo giapponese per elfi olandesi.
Allucinogeno questo fungo che trasforma la panchina degli elfi in un allegro sgabello per umani.

Pouf. Polietilene riciclabile tinto in massa ottenuto mediante stampaggio rotazionale. Il modello è resistente alla luce e all'acqua e può essere inserito della sabbia per una maggiore stabilità.

*Japanese mushroom for Dutch elves.
A magic mushroom transforms this bench for elves into a cheerful stool for humans.*

Stool. *Rotationally moulded, recyclable polyethylene with integral colour. Shitake is fade-resistant and waterproof, and can be filled with sand for additional stability for outdoor use.*

Code ST0

020

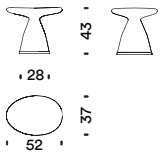

Colours



white
RAL 9003



agata grey
RAL 7038



black
RAL 9005



choco brown
RAL 8017



lacquer red
RAL 3031



fluo green
Pantone 395



St. Mark

← pp. 200, 201, 202, 203

Design Martino Gamper — 2015



Un elogio alla tradizione della sedia reso attuale dall'utilizzo di due materiali in apparente contrasto tra loro. Due versioni, come se il legno e l'alluminio, nel superamento della distinzione tra artigianato e produzione industriale, fossero l'uno la conseguenza dell'altro, e ancor di più il terzo che è l'ibrido.

Sedia. Adatte per uso esterno nella versione in alluminio; interamente in legno certificato FSC o in versione ibrida, alluminio e legno, per gli interni. La sedia è impilabile fino a 6 unità.

Tavolo bistrot in alluminio con finitura anodizzata. Questo tavolo è stato progettato per accompagnare tutte le sedie della collezione, in alluminio, in legno o in versione ibrida. Adatto per outdoor/indoor.

A homage to the tradition of the chair made contemporary by using two apparently contrasting materials. Two versions, as if wood and aluminium, in overcoming the distinction between artisan and industrial production, were one is the consequence of the other, and even more, the third, the hybrid.

***Stacking chair.** Available in aluminium for outdoor use and in FSC solid ash or hybrid version, wood and tubular aluminium, for indoor use. Stackable up to 6.*

***Bistrot table.** Table top and base is aluminium with anodized finish. This light and graceful bistro table was designed to accompany the stacking chairs in this collection, but don't restrict it to just its mates.*

Code ST1

S18-S11

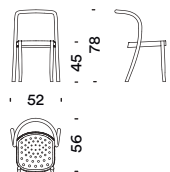

016

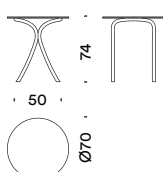

Single seats and accessories
→ vol. 2

Wood colours



natural
ash



shell
ash



agata
NCS
S 6010-G10Y
ash



grey
ash



graphite
ash



yellow ash
RAL 1012



blue
RAL 5009
ash



oxidored
RAL 3009
ash

Aluminium colours



anodized
aluminium



traffic white
RAL 9003



ocean blue
RAL 5020



orange
Pantone 718



pure green
RAL 6037



anodized
aluminium

Table



Supernatural

← pp. 187 → 193

Design Ross Lovegrove — 2005



La presenza dell'assente. I pieni e i vuoti, l'essenza che si fa presente quando è percorsa da un raggio di luce, da un alito di vento, da un corpo che l'avvolge. Più che naturale.

Sedia e poltroncina. Monoscocca in polipropilene rinforzato. Cuscinetti termoformati con espanso e tessuto ignifugo. La sedia è impilabile fino a 8 unità. La poltroncina è impilabile fino a 4 unità.

Tavolo. Polipropilene rinforzato con colonna e base in acciaio rivestiti in polipropilene.

The presence of the absent. The full and the empty space, the essence of which is present when it is traversed by a ray of light, a breath of wind, a body that surrounds it. Naturally.

***Chair and small armchair.** One-piece reinforced polypropylene. Heat-formed flame-retardant fabric bonded to foam. Chairs can be stacked up to 8 high. Small armchairs can be stacked up to 4 high.*

***Table.** Reinforced polypropylene over steel column and base covered in polypropylene.*

Code SU0



Chair



Small armchair



Table





Supernatural

Code SU0

156-M66

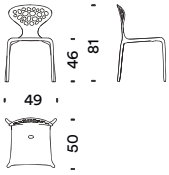

061

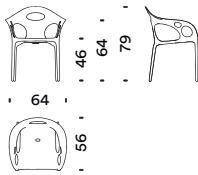

0S1

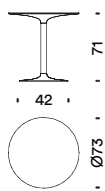

Outdoor — Technical info

Chairs bi-colours



Pantone
7511 / 7467
turquoise /
caramel



RAL
9010 / 395
white /
fluo green



RAL
9005 / 021
black / orange



RAL
9005 / 395
black /
fluo green

Chairs and armchairs colours



RAL 9005
black



RAL 9010
pure white



Pantone 7467
turquoise



Pantone 464
caramel



Pantone 395
fluo green



Pantone 718
terra di Siena

Table colours



Pantone 464
caramel



Pantone 395
fluo green

The Big Easy

← pp. 162, 163

Design Ron Arad — 1991



La bella stagione. Nata dal cuore, nella stagione del risveglio, questa collezione mantiene nell'animo la primavera che l'ha generata.

The sweet season. Born from the season of reawakening, this collection carries spring in its heart and soul.

Poltrona. Polietilene tinto in massa ottenuto mediante stampaggio rotazionale. Il materiale è riciclabile al 100% e può essere utilizzato all'esterno in quanto resistente alla luce e all'acqua. La versione laccata in ambienti all'esterno non è raccomandata.

Armchair. Rotationally molded, 100% recyclable polyethylene with integral fade-resistant and waterproof colours for outdoor use. Lacquer version is not recommended for outdoor use.

Code TZ0

001-161

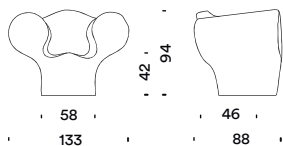

Polyethylene colours



RAL 9002
white chalk



RAL 3020
traffic red



RAL 9005
black

Laquered colours



RAL 9003
traffic white
glossy



RAL 9005
black
glossy



RAL 5002
ultramarine
glossy



Toogou

← pp. 085, 086, 087

Design Birsel+Seck — 2009



Ayse Birsel dalla Turchia e Bibi Seck nato a Parigi da genitori senegalesi, hanno colto l'opportunità di realizzare idee vicine alle loro radici: Toogou, che in Wolof significa sedersi.

Poltrone. Fatta interamente a mano a Dakar, in Senegal, da artigiani locali, questa collezione è costruita con cordini in polietilene – tradizionalmente utilizzati per realizzare reti da pesca – tessuti direttamente su struttura d'acciaio con trattamento antiruggine per uso interno/esterno.

Ayse Birsel, from Turkey, and Bibi Seck, born in Paris to Senegalese parents, enjoyed this opportunity to realize ideas close to their roots: Toogou, which means sitting in Wolof.

Armchairs. Handmade entirely in Dakar, Senegal by local artisans, this collection is constructed of a durable polyethylene cord – traditionally used to make fish nets – woven directly to the tubular steel frame with anti-rust treatment for indoor/outdoor use.

Code TU0

050

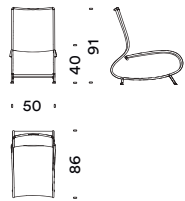

Pattern colours



01-rouge
02-rose



03-orange
11-oxyde



11-oxide
14-noir



11-oxyde
15-bleu ciel



Design Patricia Urquiola — 2009



Il continente africano è ricco di creatività, materiali e idee, una fonte di ispirazione per i designer. Il contributo di Urquiola alla collezione M'Afrique è Touti, una piccola seduta che mette in mostra magnificamente le intricate trame caratteristiche del Senegal.

Pouf. Fatta interamente a mano a Dakar, in Senegal, da artigiani locali, questa collezione è costruita con cordini in polietilene – tradizionalmente utilizzato per realizzare reti da pesca – tessuti direttamente su struttura d'acciaio con trattamento antiruggine per uso interno/esterno.

The African continent is rich in creativity, materials and ideas, a source of inspiration for designers. Urquiola's contribution to the M'Afrique collection is Touti, a small stool that exquisitely showcases the intricate woven patterns unique to Senegal.

Stool. Handmade entirely in Dakar, Senegal by local artisans, this collection is constructed with a durable polyethylene cord – traditionally used to make fish nets – woven directly to the tubular steel frame with anti-rust treatment for indoor/outdoor use.

Code TV0

017

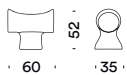

Pattern colours



multirouge
01-rouge
14-noir
12-blanc
05-jaune
08-vert



multivert
14-noir
08-vert
05jaune
12-blanc



Tropicalia

← pp. 164 → 177

Design Patricia Urquiola — 2008



Patricia Urquiola evoca l'esotico con la collezione Tropicalia. Giocosa e leggera, Day bed e Cocoon offrono rifugio proprio come un bozzolo, mentre gli sgargianti colori intrecciati sulla struttura traggono ispirazione dal carnevale e dal piumaggio degli uccelli tropicali.

Chairs, armchairs and chaise longue. Struttura in acciaio inox naturale o verniciato per uso esterno. Sottopiedi in PVC. Intreccio in filo tecnopolimero.

Cocoon, Day bed. Struttura in acciaio verniciato rosso RAL 3020 e intreccio in filo tecnopolimero. Il materasso del Day bed è in poliuretano espanso adatto per l'esterno; i cuscini sono in fibra poliestere per uso esterno. Cocoon e Day bed vengono forniti con i cuscini accessori.

Patricia Urquiola evokes the exotic in her Tropicalia collection. Playful and lighthearted, Cocoon Daybed and swing are as sheltering as the name implies, while the brilliant colours woven over their frames are inspired by Carnival and tropical bird plumage. For indoors and outdoors.

Chairs, armchairs and chaise longue. Frame is stainless steel or painted in a finishing suitable for outdoor use; on PVC glides. Engineering polymer cord woven on frame.

Cocoon, Day bed. Engineering polymer cord woven on frame. Frame is red RAL 3020 painted steel. Cushions are polyester fiber fill and day bed mattress is polyurethane foam; all are suitable for outdoor use. The collection is completed with cushions.

Code TR0



Chaise longue



Armchairs



Chairs



Cocoon



Day bed





Code TR0

458-459

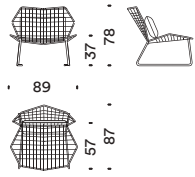

461-462

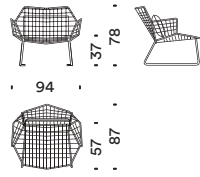

471

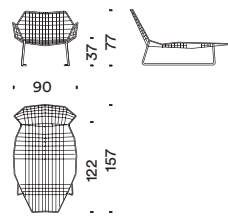

464-465

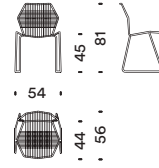

467-468

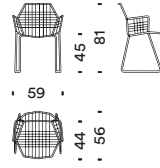

128

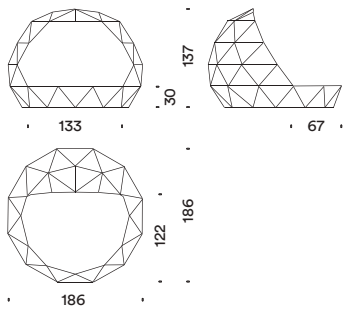

060

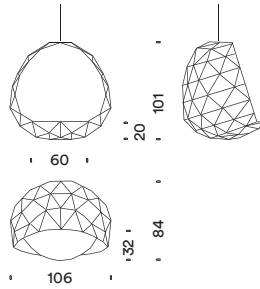

Frame colours



RAL 9003
signal white



RAL 9005
black



RAL 3020
traffic red



stainless
steel



NCS
S 5005-Y20R
concrete

Weavers bench

← pp. 093, 094/095

Design Tord Boontje — 2016



«La Weavers bench é nata da un modello in piccola scala che ho fatto per esplorare i modi in cui la superficie di un intreccio possa creare una forma morbida per il corpo. Quando ho mostrato il modello a Patrizia lei lo ha visualizzato come una grande seduta e abbiamo deciso che sarebbe potuta essere molto carina e dinamica. Quando sono stato a Dakar, abbiamo realizzato la struttura direttamente dal modello e abbiamo iniziato a intrecciare. Questa panca é stata creata senza disegni o computer, solo con mani esperte». –Tord Boontje

Panca. Fatta interamente a mano a Dakar, in Senegal, da artigiani locali, questa collezione è costruita con cordini in polietilene – tradizionalmente utilizzati per realizzare reti da pesca – tessuti direttamente su struttura d'acciaio con trattamento antiruggine per uso interno/esterno.

«The Weavers bench came from a small scale model that I had made, exploring how the surface of the weaving could form a soft shape for the body. When I showed this model to Patrizia, she interpreted this as being one large seat, which we agreed could be very nice and dynamic. When I went to Dakar we made the frame directly from the model and started weaving. This bench was made without drawings or computers, only with skilled hands».

–Tord Boontje

Bench. Handmade entirely in Dakar, Senegal by local artisans, this collection is constructed with a durable polyethylene cord– traditionally used to make fish nets – woven directly to the tubular steel frame with anti-rust treatment for indoor/outdoor use.

Code WE0

06N

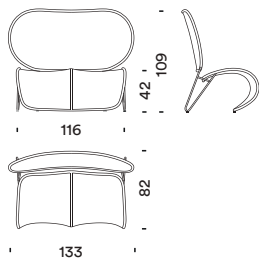

Pattern colours



vert
07-vert lagon
17-vert clair
15-bleu ciel



rouge
10-violet
01-rouge
03-orange



Moroso

3. Outdoor

art direction

Patrizia Moroso

set coordinator

Marco Viola

photography

Alessandro Paderni

[studio Eye]

textile and colour advisor

Giulio Ridolfo

graphic design

Designwork

graphic layout

Jessica Etro

intro text

Lorenzo Taucer

colour separation

Lucegroup.it

thanks to

Giuliana De Luca

Natasa Srebro

Tanja Mlinar

for technical support

printed in Italy

by Grafiche Filacorda

with H-UV Technology

2018 ©Moroso Spa

Moroso Spa
via Nazionale 60
33010 Cavalicco UD
— Italy
T +39 0432 577 111
info@moroso.it

Milano Showroom
via Pontaccio 8/10
20121 Milano
— Italy
T +39 02 7201 6336

Moroso Ltd
London Showroom
7-15 Rosebery Avenue
London EC1R-4SP
— UK
T +44 (0)20 3328 3560
info@moroso.co.uk

Moroso USA
New York Showroom
146 Greene Street
New York, NY10012
— USA
T +1 212 334 7222
info@morosousa.com

Moroso Belgium
Clustr
Ham 1, 9000 Gent
— Belgium
T + 32 (0) 9 258 88 56
info@morosobelgium.be

Amsterdam Showroom
Cruquiusweg 94F
1019 AJ Amsterdam
— The Netherlands
T +31 (0)20 694 64 00
amsterdam@moroso.n

Köln Showroom
Design Post Köln
Deutz-Mülheimer Straße 22A
50679 Köln
— Germany
T +49 221 690 650
info@designpostkoeln.de

Moroso Gulf Office
JBC3, Office number 2407
Cluster Y
Jumeirah Lake Towers
Dubai
— UAE
T +971 (0)45 521 878
info@morosogulf.it

MOROSO[™]

