

# ARPER FOR EDUCATION

arper

# CONTENTS

---

<b>Arper for Education</b>	<b>5</b>
<b>Our company</b>	<b>6</b>
<b>Collections</b>	<b>14</b>
<b>On Educational Segment</b>	<b>23</b>
<b>Rethinking how and where we learn</b>	<b>59</b>
<b>More in depth, technical details</b>	<b>85</b>

## Arper on the Go

Scan the QR code to download the Arper app on your tablet and explore our world.



# Arper for Education

**As our communal spaces reopen and students return to schools, we need flexible solutions to accommodate the evolving needs of learning environments.**

**From individual workspaces to shared classrooms or libraries, we need modular furniture options that can be reconfigured to maintain a safe space. Arper's product offerings for the learning sector have always prioritized customization and adaptability, addressing the individual needs of students of all ages and the flexibility to meet the needs of the moment.**

Arper  
=  
arredamento  
(furniture)  
+  
per  
(for)

**We are a fast-growing company founded in 1989 — a family business guided by an integrative, human-centered approach. We have grown from a furniture manufacturing business to an international design presence, dramatically increasing our turnover and adding hundreds of new employees to the Arper family.**



# Structure

## Arper capabilities:

- Three local production facilities, based in Italy (Treviso), US (High Point, North Carolina), and Japan allow us to ensure prompt delivery and assistance
- A global organization including 12 showrooms, 6 subsidiaries, 4 branches, 2 meeting hubs and a network of representatives guarantee a presence in over 90 countries
- Long-term partnerships with over 200 suppliers with unique expertise enable us to provide a full range of capabilities, from upholstery to metal work to carpentry
- Our product development team and sampling facilities are committed to research the latest innovations to be applied to our products

## Structure

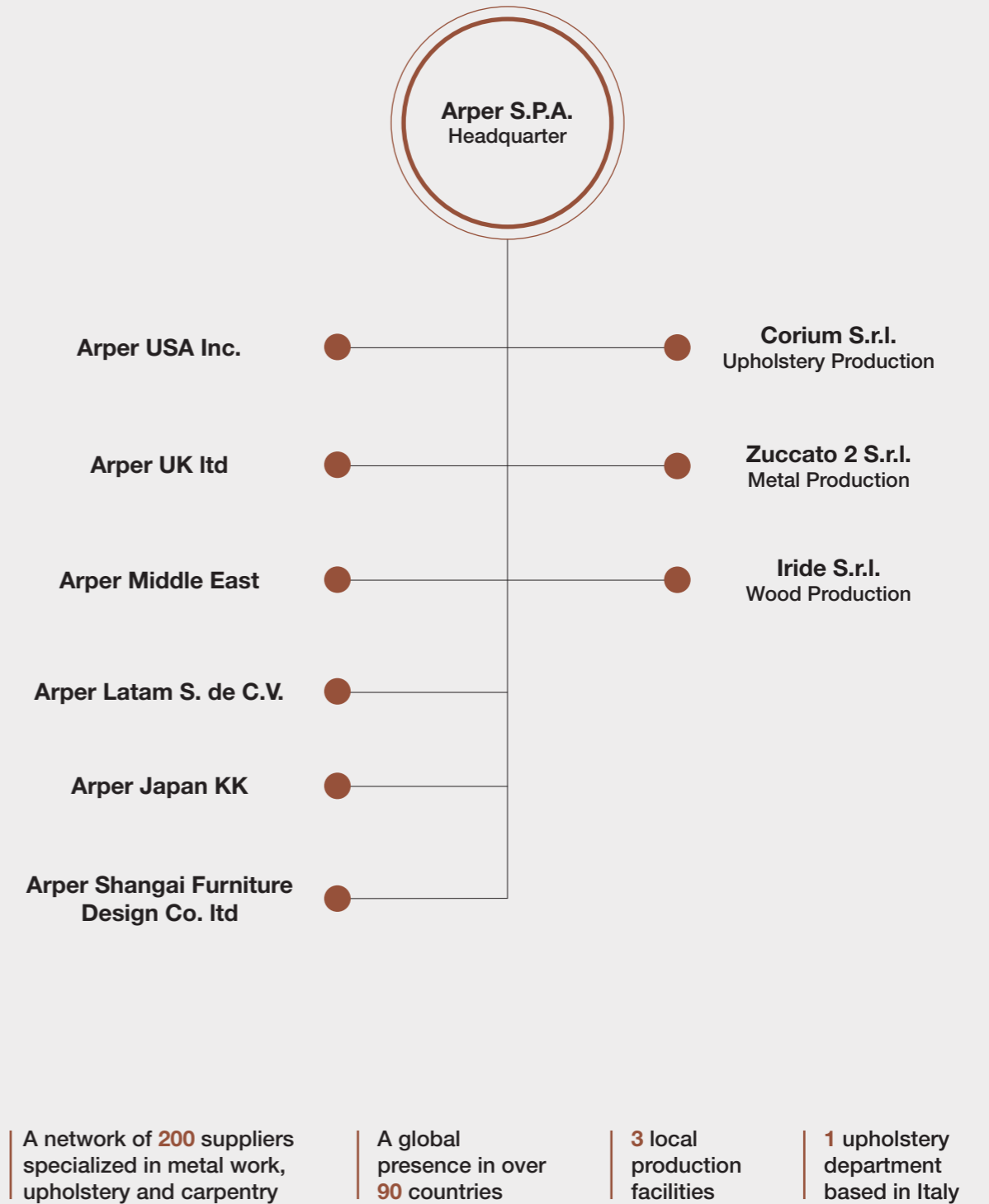

# ARPER GLOBAL PRESENCE:



Arper

2020

## 12 Showrooms

- New York
- Londra
- Los Angeles
- Chicago
- Tokyo
- Milano
- Monastier
- Dubai
- Oslo
- Amsterdam
- Mexico City
- Colonia

## 6 Subsidiaries

- China
- Japan
- Mexico
- United Arab Emirates
- United Kingdom
- United States of America

## 3 Branches

- Belgium
- Singapore
- Sweden

## 2 Meeting Hubs

- Beernem (Belgium)
- Munich

An extensive network of dealers across 90 countries.  
89% of our 2019 turnover came from export.



# A TRADITION OF CRAFT AN EYE ON DESIGN

**1989**

Arper is established by the Feltrin family



**1998**

Arper meets Lievore Altherr Molina



**2000**

Arper moves away from furniture manufacturing to become a design-oriented company



**2002**

In-house upholstery



**2005**

Arper founds environmental department



**2008**

Opening of Arper USA, Inc.



Arper

2020

**2010**

Opening of the flagship showroom in Milan, first of 11 international showrooms



**2012**

Launch of Lina Bo Bardi project



**2016**

Opening of a subsidiary in Japan and of a showroom in Tokyo.



**2014**

Opening of warehouse and production facilities in North Carolina



**2017**

Opening of a branch and of a meeting hub in Belgium, and of a new factory in North Carolina



**2018—present**

Ongoing global expansion with the opening of a showroom in Los Angeles and of two subsidiaries in Mexico and China



# Collections

**Every part of the product development process—from design to production to long-term impact—is carefully considered, bringing function, aesthetic, detail together in elegant resolution.**

**We develop and manufacture custom solutions to complement our furniture range for applications in hospitality, work and home.**

**We are proud to support customers and their partners in creating actionable solutions.**

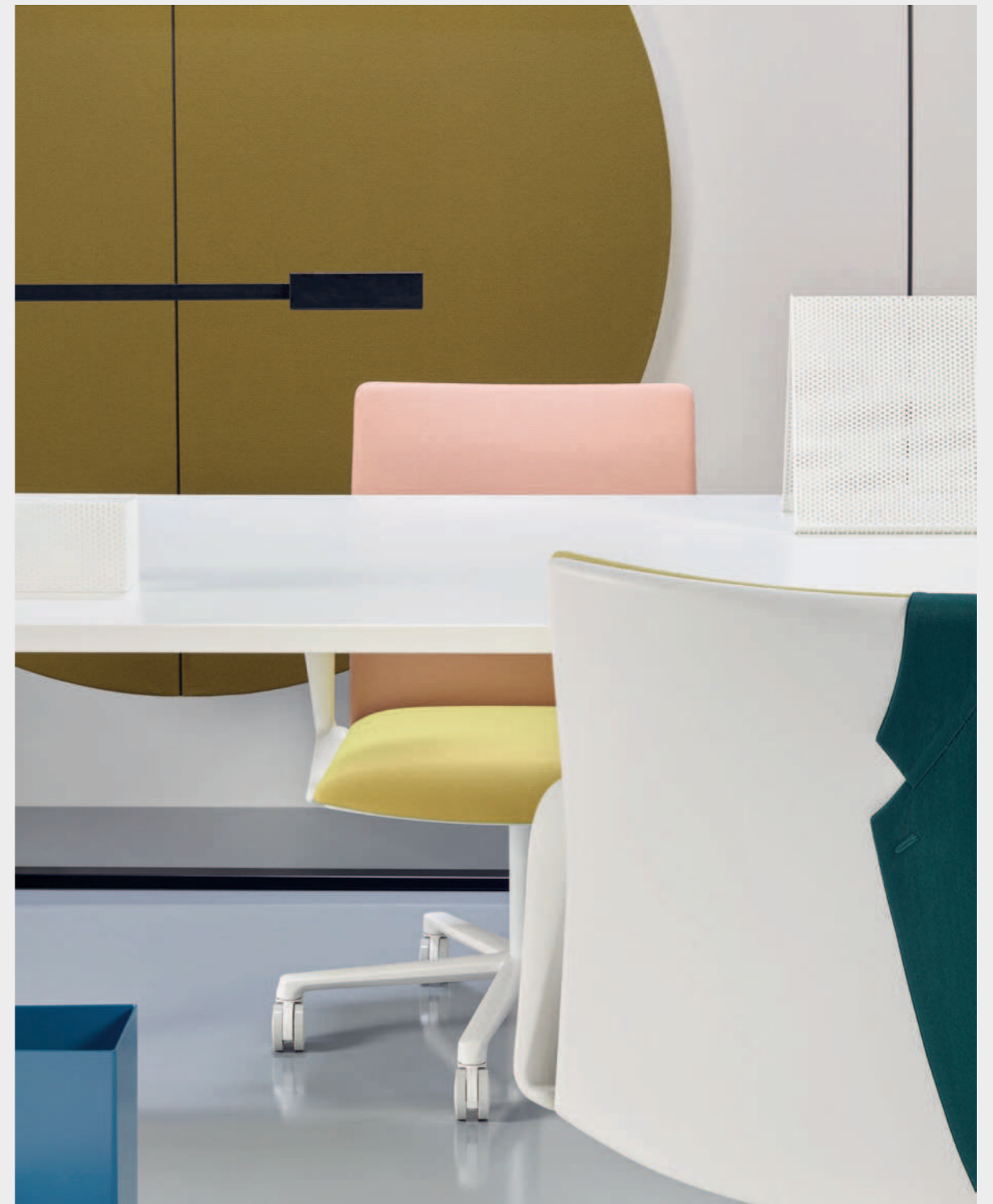



CHAIRS

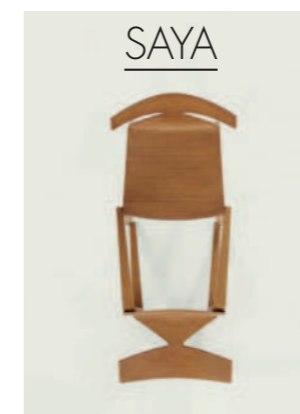
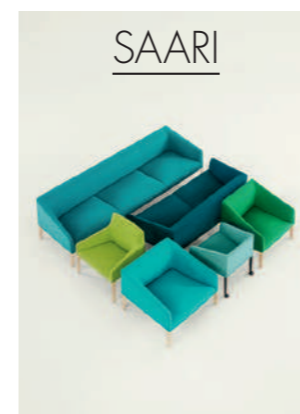
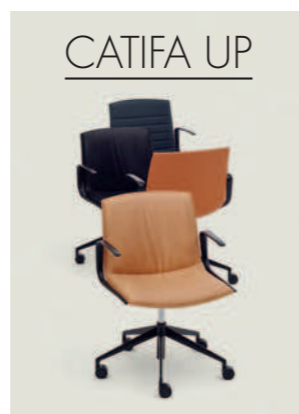
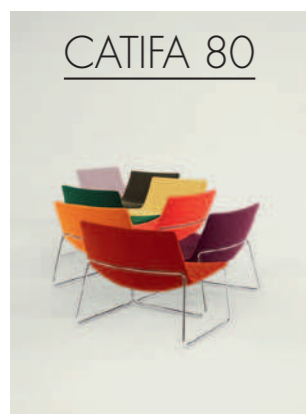
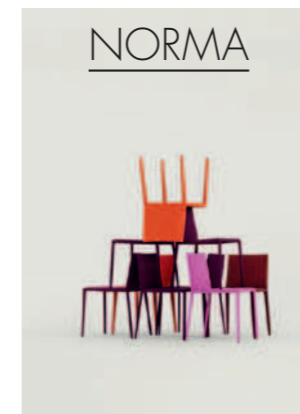
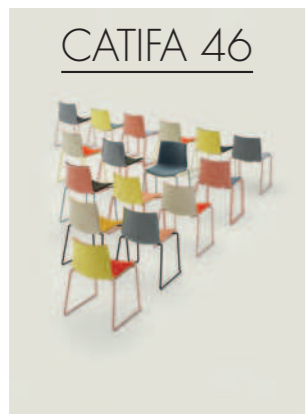
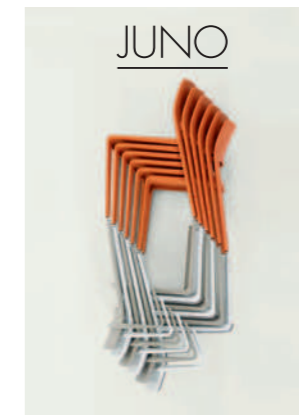
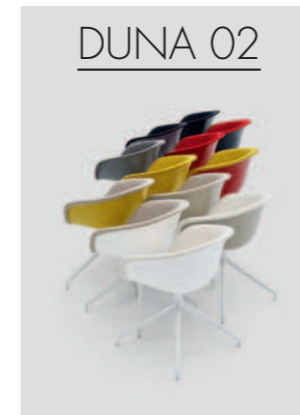
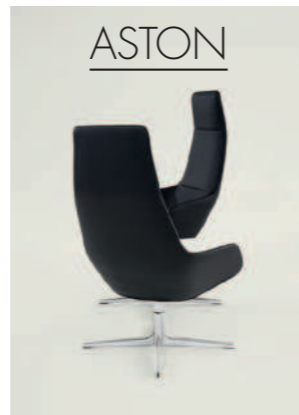
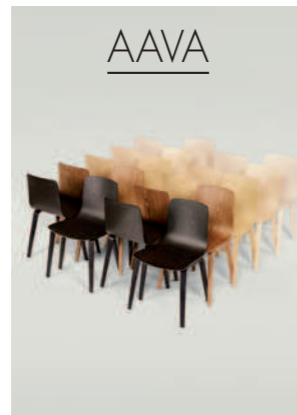

Arper

2020



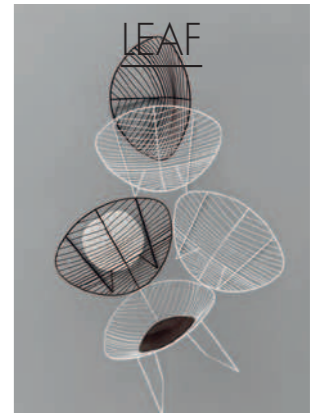
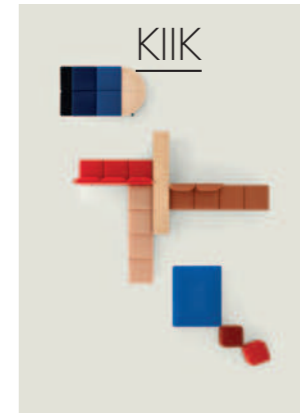
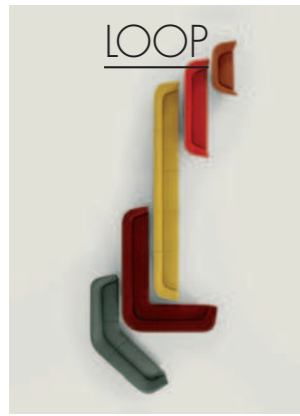
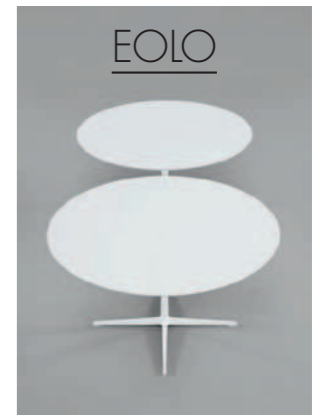
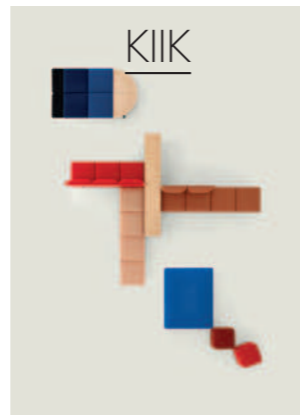
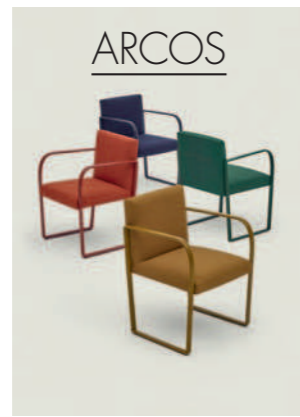

Arper

2020

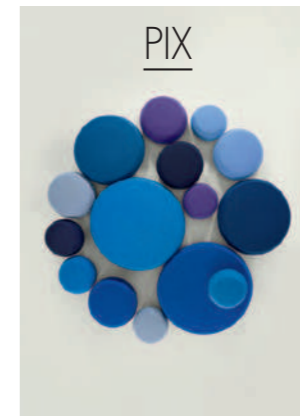
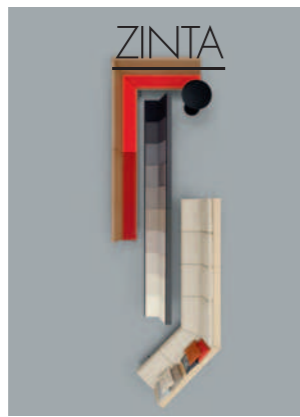

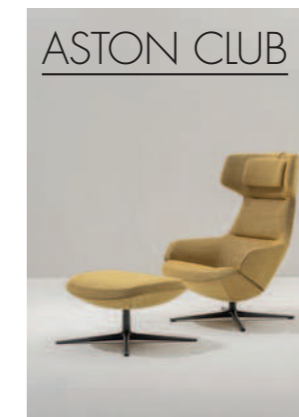
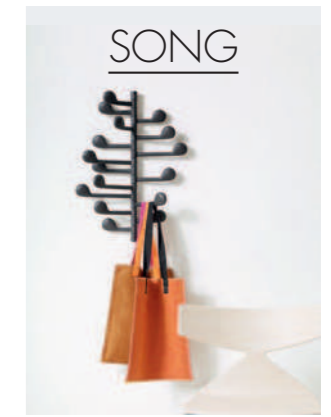

# ON EDUCATIONAL SEGMENT



**Royal College of Surgeons**

Dublin / Ireland

- Architect:

Henry J Lyons Architects

- Photo:

Donal Murphy

- Arper products:

Aava, Catifa 46,

Colina, Duna 02, Juno

- Living / break out & lounge area

Arper



Selected References



Education





Arper

COLLABORATIVE STUDY ZONE

2

Education



Harvard University  
Smith Campus Center  
Cambridge / USA

- Architect:  
Hopkins Architects,  
Bruner/Cott Architects
- Photo:  
Nic Lehoux
- Arper products:  
Catifa 80, Pix
- Living / break out & lounge area

Arper



Education



**Barnard College  
The Milstein Center  
New York / USA**

- Architect: SOM
- Photo: Magda Biernat
- Arper products: Aava
- Living / break out & lounge area



Arper

Selected References



Education



**H-FARM**

Treviso / Italy

- Photo: Marco Covi
- Arper products:  
Leaf, Kinesit, Pix
- Conviviality / bar & cafeteria,  
Learning / classroom,  
Collaboration / workplace

Arper



Selected References



Education





Selected References





- TU Delft
- Faculty of Applied Sciences
- Delft / The Netherlands
- Architect: Ector Hoogstad Architecten
- Photo: Hans Morren
- Arper products: Catifa 46
- Learning / reading room

Arper



Education





Arper

Education



- Erasmus University College**  
Rotterdam / The Netherlands
- Architect: Erick Van Egeraat
  - Photo: Ossip van Duivenbode
  - Arper products:  
Catifa 46, Catifa 80
  - Collaboration / workplace

Arper





- Haagsche Hogeschool  
Delft / The Netherlands
- Architect: Syb van Breda,  
Royal HaskoningDHV
- Photo: Hans Morren
- Arper products:  
Catifa 46, Palm
- Learning / reading room

Arper

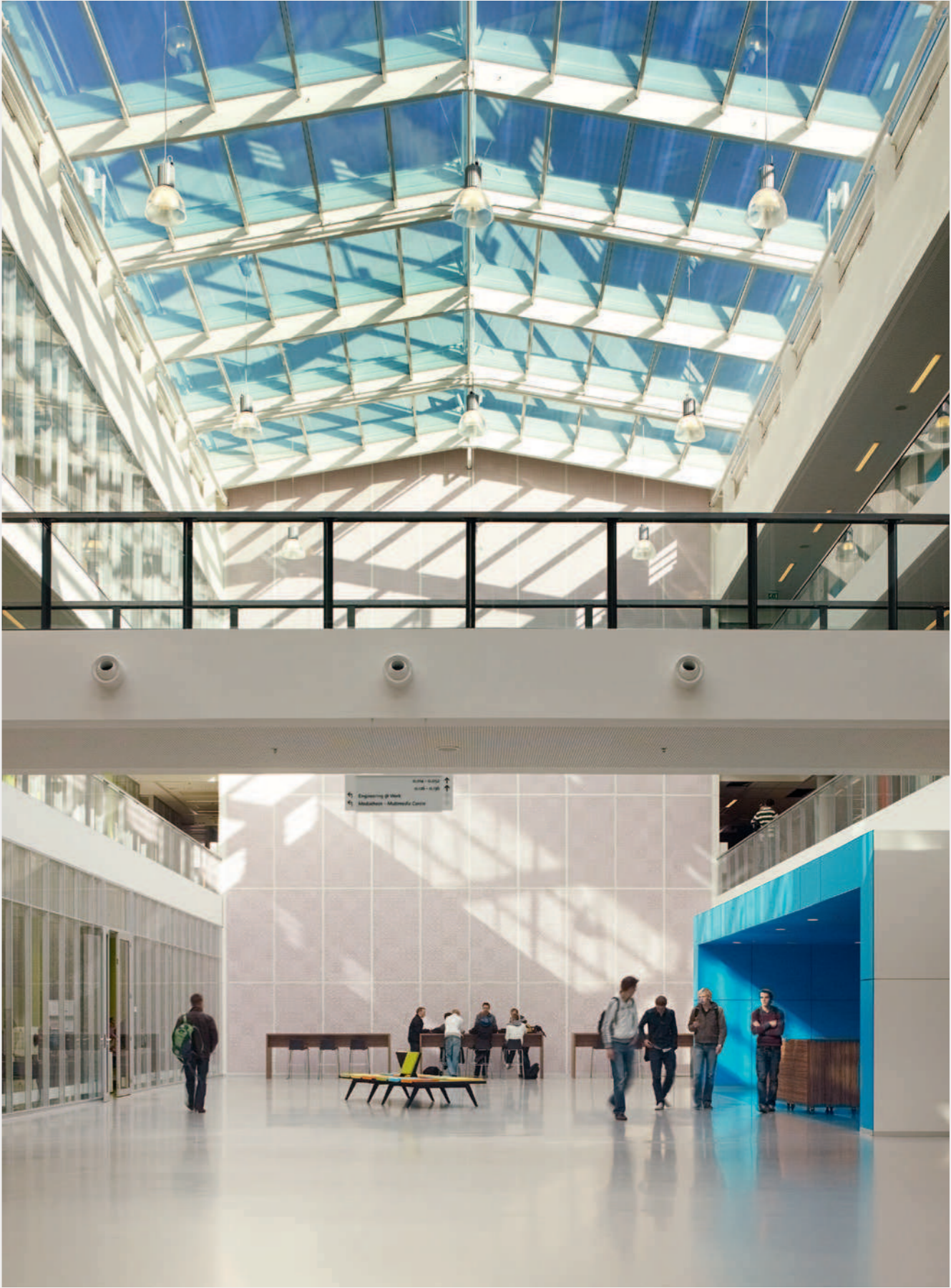

Education



**Georgetown University  
School of Continuing Studies  
Georgetown / USA**

- Architect: Studios Architecture
- Photo: Bruce Damonte
- Arper products:  
Catifa 46, Catifa 80, Pix
- Living / lounge & break out area  
Conviviality / bar & cafeteria

Arper



Selected References



Education



Ryerson University  
Student Learning Centre  
Toronto / Canada

- Architects: Zeidler Partnership Architects, Snøhetta
- Photo: doublespace photography, Lorne Bridgman
- Arper products: Catifa 80
- Living / lounge & break out area



Arper

Selected References



Education



Université Paris-Sorbonne

Paris / France

- Architect: GPAA
- Photo: 11h45
- Arper products:  
Catifa 46, Pix
- Learning / reading room



Arper

Education



**Kindergarten Susi Weigel**  
**Bludenz / Austria**  
 – Architects: Bernardo Bader Architekten  
 – Photo: Adolf Bereuter  
 – Arper products: Pix  
 – Living / lounge & break out area

Arper



Education



Oodi Helsinki Central Library

Helsinki / Finland

- Architect:  
ALA Architects
- Photo:  
Tuomas Uusheimo
- Arper products:  
Catifa Sensit, Saari



Arper

Education



**PEMA Tower Municipal Library**

Innsbruck / Austria

- Architect:  
LAAC Architekten
- Interior Design:  
reiter design
- Photo:  
Marc Lins
- Arper products:  
Catifa 46, Catifa 53,  
Meety, Nuur

Arper



Education







Arpe

Education



RETHINKING  
HOW AND  
WHERE  
WE LEARN



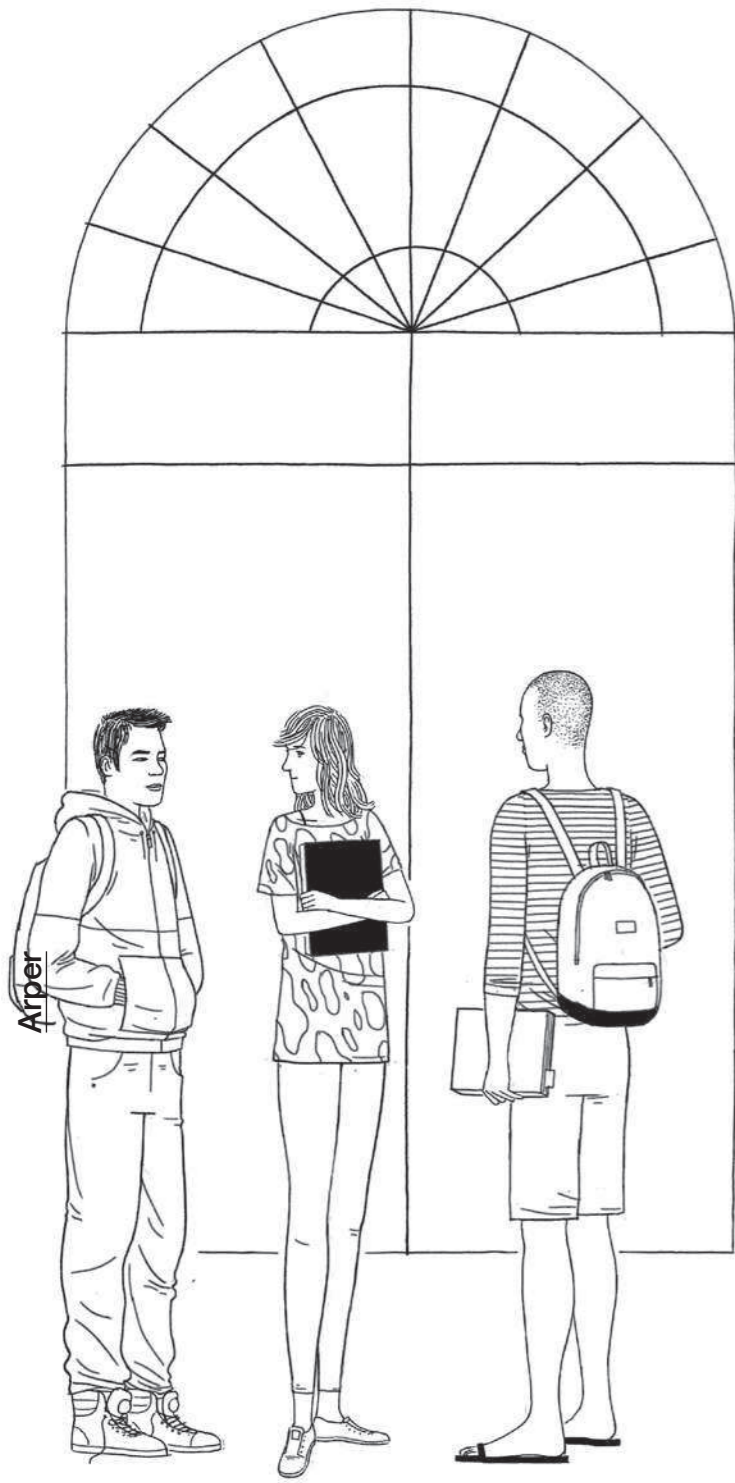

# Reimagined Spaces with Adaptability

Arper has always put flexibility at the forefront of our designs and promoted a sense of balance between work and personal life.

In the following proposals, we have taken some of our favorite designs and explored how they can be personalized and modified to adjust to the evolving needs of this time. With a core value of adaptability, Arper has created flexible furniture to meet the demands of the moment—and every moment to come.



**Lobby Area**

Public learning areas like lobbies can present an opportunity to rest, recharge, read, or meet in small groups—but at a safe distance. This configuration of Kiik makes the space between seating functional with a small, useful table.

Arper



Education



**Break Out Room**

Break out areas are essential as informal places to work and exchange ideas. Paravan helps maintain creativity and an exchange of ideas while still safeguarding the space. Cross's expansive tabletop allows for up to 4 individuals at a table while still maintaining safe distancing practices.





**Laboratory**

Laboratory work stations can increase opportunities for focus and safety with Paravan panels which help to reduce noise as well as keep a safe distance. Here Planesit task chairs and Nuur table combine to create a flexible space to learn.

Arper



Education



**Co-Working**

Paravan Mood can be used as a desk divider, as seen here with the spacious Cross table and Planesit stools. Used together, these offerings provide safe working spaces while still maintaining a sense of exchange and camaraderie.

**Reimagined Spaces with Adaptability**





**Collaborative work**

Individual or small group learning is made possible by Cila Go – an armchair with optional built-in desk or castors. This compact piece is virtually a mobile classroom, all in one chair that can be easily moved, cleaned, and used as storage.



Arper

Education





Education



Arper



Education

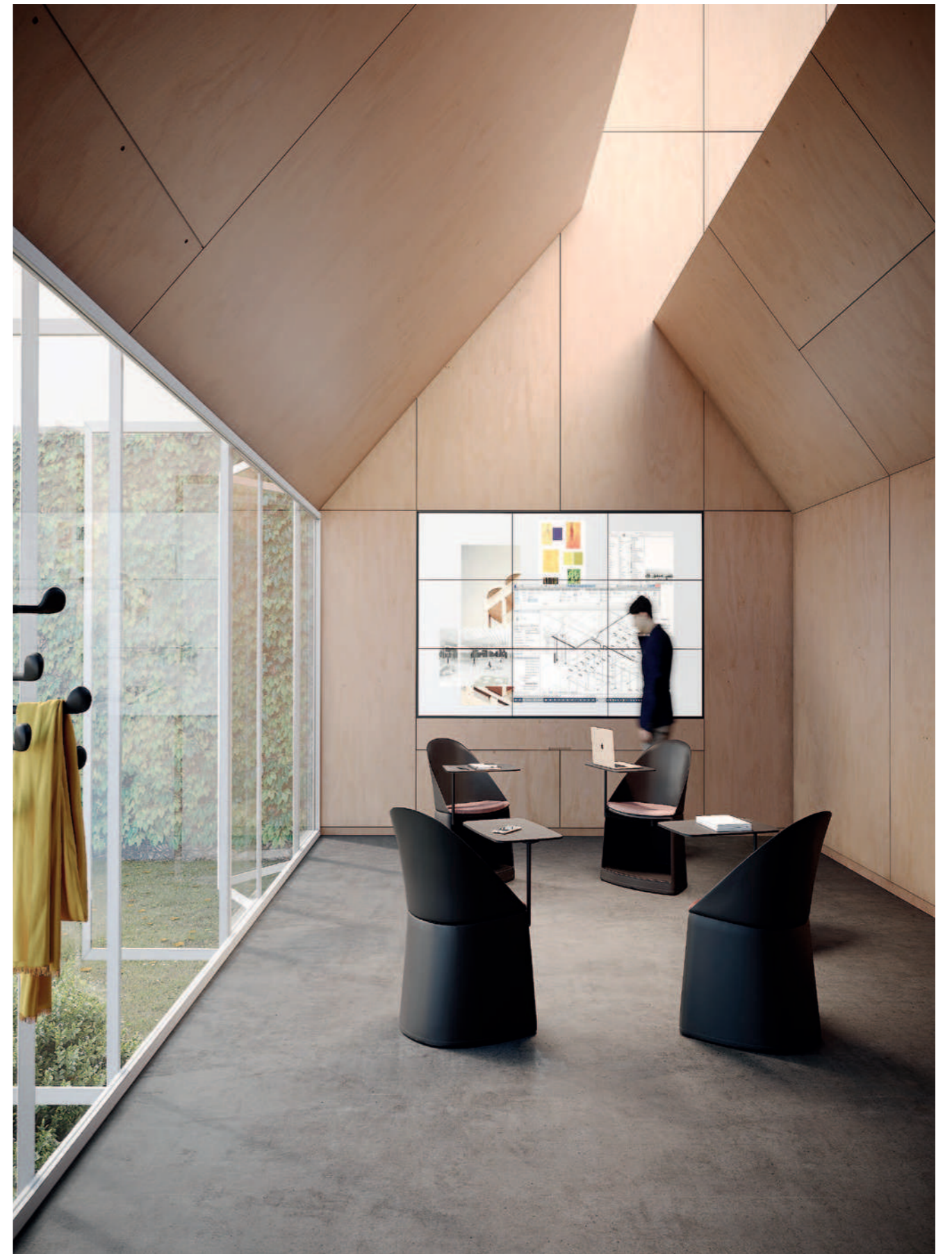



**Auditorium**

For large groups or auditoriums, Stacy chair, thanks to its light weight, ease of movement and a tablet that can be used as a desk, guarantees the possibility of fast reconfiguration within the space, maintaining an adequate safe distances.





**Cafeteria**

Communal dining helps foster an exchange of ideas and learning. In our new era, maintaining effective distance is key. Spaced apart but easy to rearrange, these Catifa chairs are lightweight yet durable making them a breeze to reconfigure as needed.

Arper



**Reimagined Spaces with Adaptability**



Education



**Outdoor Areas**

Outdoor areas provide a space for conversation and relaxation. Adell, one of our newest collections, helps to confer a comfortable atmosphere and can be rearranged as needed to meet the demands of the moment.



Arper

Education





Arper

Education



MORE  
IN DEPTH,  
TECHNICAL  
DETAILS



**Kiik Collection overview**  
 (For more information please refer to User's Manual downloadable from our website)

**Structure**

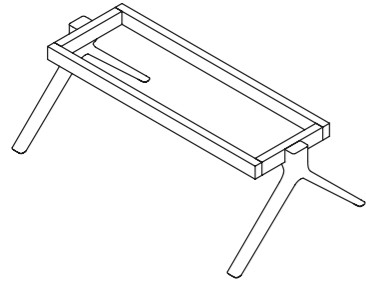

Art. 6302 – S126  
 — Dimensions: 92,6x33x35 cm  
 — Dimensions of complete item: 126x63 cm  
 — Fills 2 units

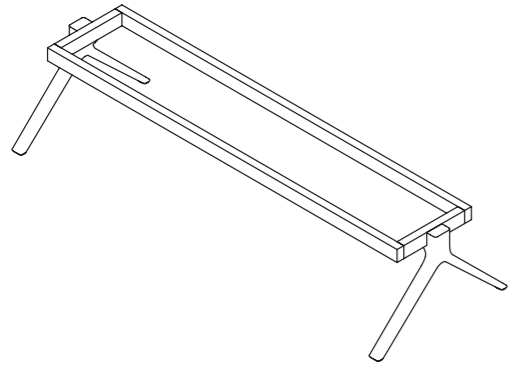

Art. 6301 – S189  
 — Dimensions: 155,6x33x35 cm  
 — Dimensions of complete item: 189x63 cm  
 — Fills 3 units

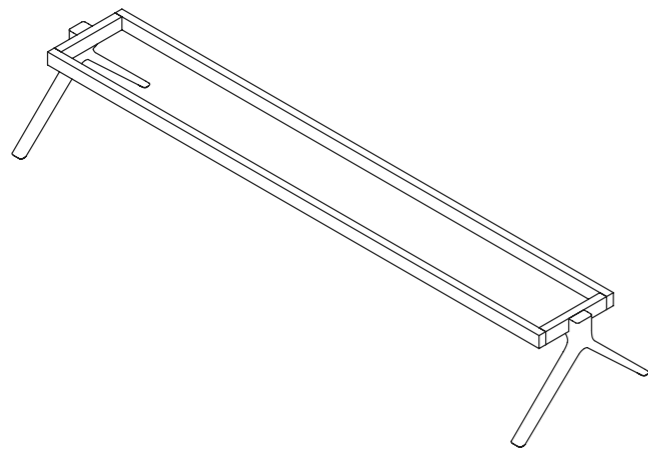

Art. 6300 – S252  
 — Dimensions: 218,6x33x35 cm  
 — Dimensions of complete item: 252x63 cm  
 — Fills 4 units

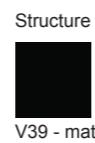

**Seating modules**

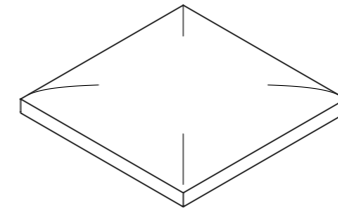

Art. 6303 – Cushion  
 — Dimension: 63x63x10 cm  
 — Fills 1 unit

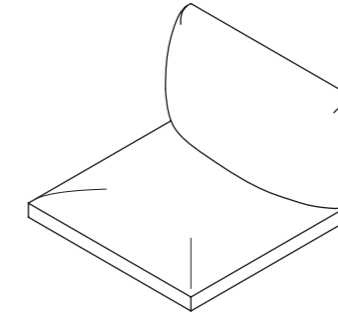

Art. 6304 – Cushion with standard backrest  
 — Dimension: 63x63x40 cm  
 — Fills 1 unit

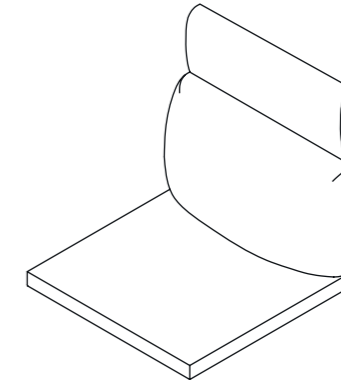

Art. 6332 – Cushion with high backrest  
 — Dimension: 63x63x60 cm  
 — Fills 1 unit

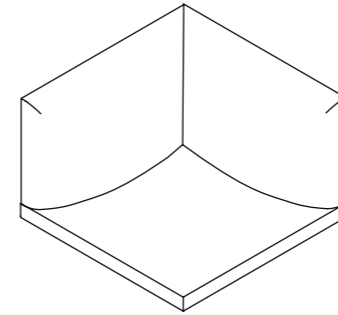

Art. 6328 / 6329 – Angular cushion with standard backrest  
 — Dimension: 63x63x40 cm  
 — Fills 1 unit

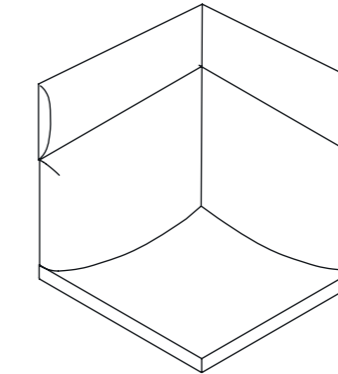

Art. 6330 / 6331 – Angular cushion with high backrest  
 — Dimension: 63x63x60 cm  
 — Fills 1 unit



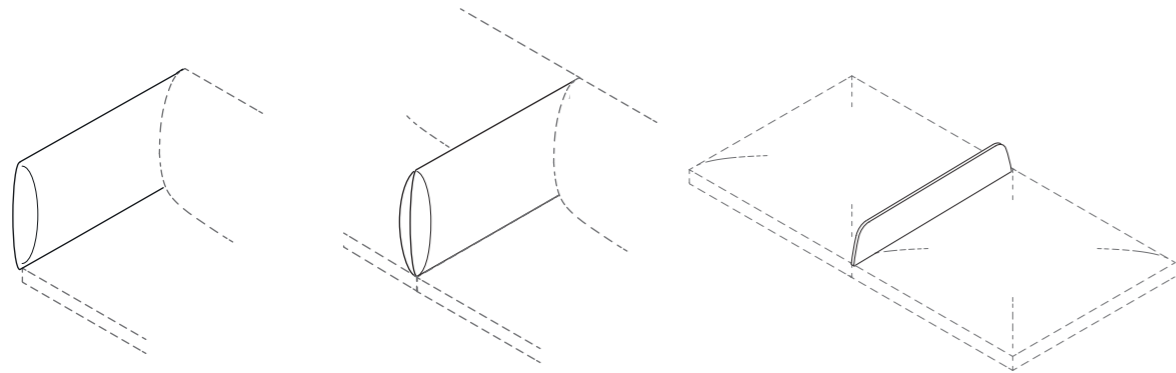

Art. 6334/6335 – Side armrest

Art. 6333 – Middle armrest

Art. 6336 – Separator between seats

Table modules

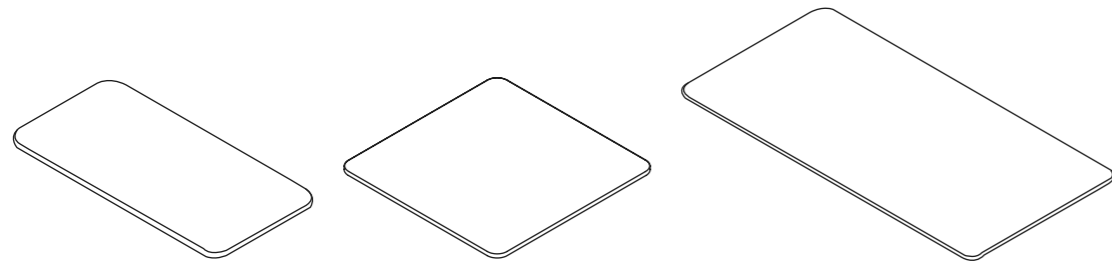

Art. 6310 – Rectangular side table  
— Dimension: 31,5x63 cm  
— Thick: 1,4 cm  
— Fills 0,5 unit

Art. 6309 – Square side table  
— Dimension: 63x63 cm  
— Thick: 1,4 cm  
— Fills 1 unit

Art. 6308 – Rectangular side table  
— Dimension: 126x63 cm  
— Thick: 1,4 cm  
— Fills 2 units

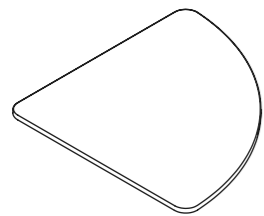

Art. 6311 – Quarter round side table  
— Dimension: 63x63 cm  
— Thick: 1,4 cm  
— For compositions with 90° corner

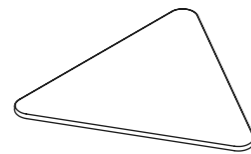

Art. 6312 – Triangular side table  
— Dimension: 63x63x63 cm  
— Thick: 1,4 cm  
— For compositions with 120° corner

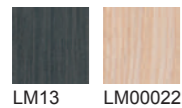

LM13

LM00022

Console

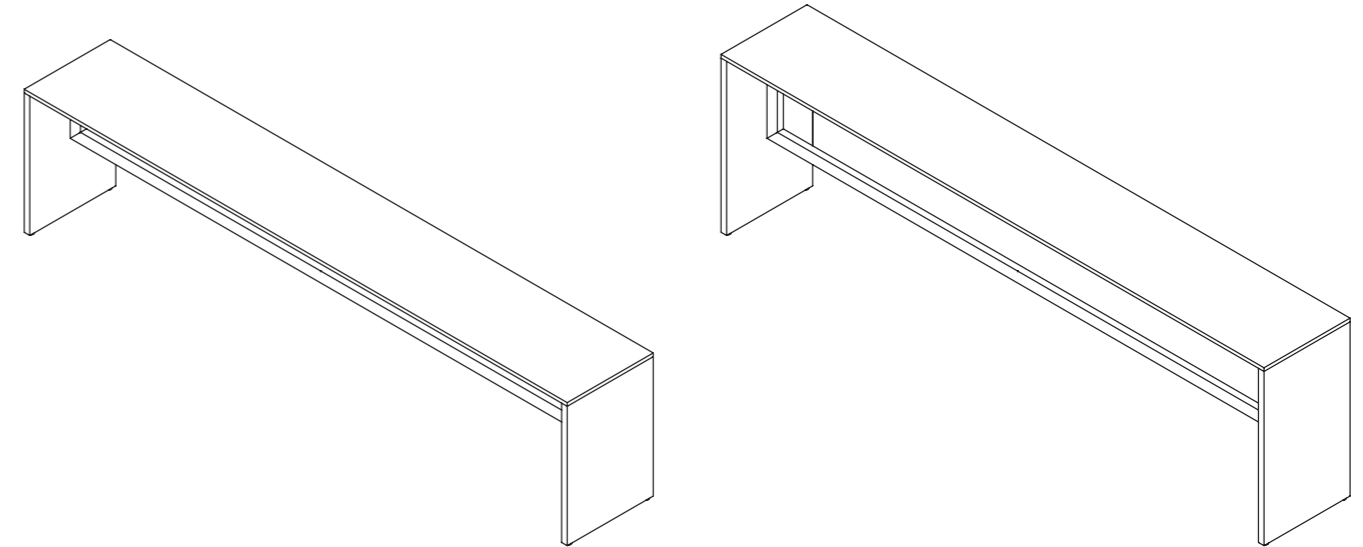

Art. 6305 – Console h 58 cm  
— Dimensions: 252x40x58 cm

Art. 6306 – Console h. 72 cm  
— Dimensions: 252x40x72 cm

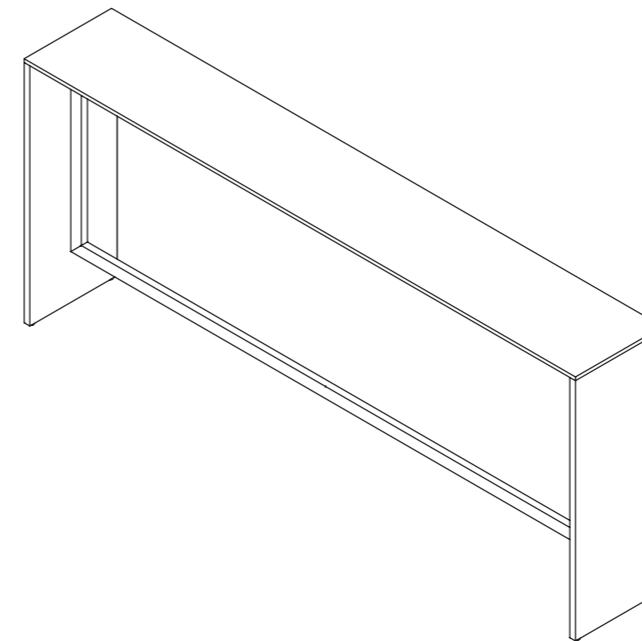

Art. 6307 – Console h. 105cm  
— Dimensions: 252x40x105 cm



Ottoman

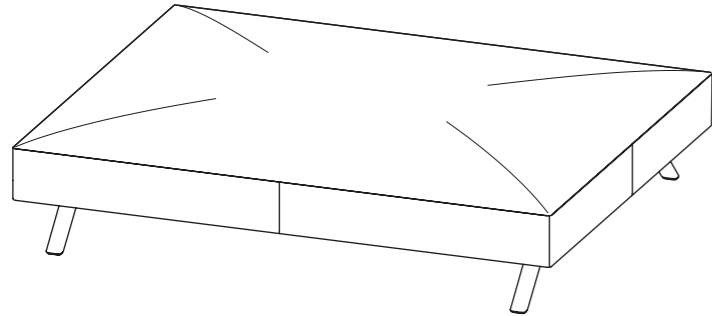

Art. 6313 – Ottoman  
— Dimensions: 126x157,5x36 cm

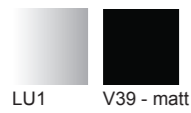

Link

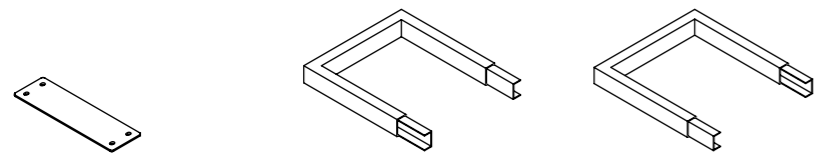

Art. 6316 – Plate-shaped link  
— Dimensions: 26,6x8 cm

Art. 6314 – C-shaped link  
— Dimensions: 31x33x5 cm

Art. 6315 – Island-shaped link  
— Dimensions: 33,4x36x5 cm



Options



USB

Composition Examples



- 1 x Art. 6300 – Structure S252
- 3 x Art. 6304 – Cushion with backrest
- 4 x Art. 6310 – Rectangular table 31,5x63 cm
- 2 x Art. 6314 – C-shaped link

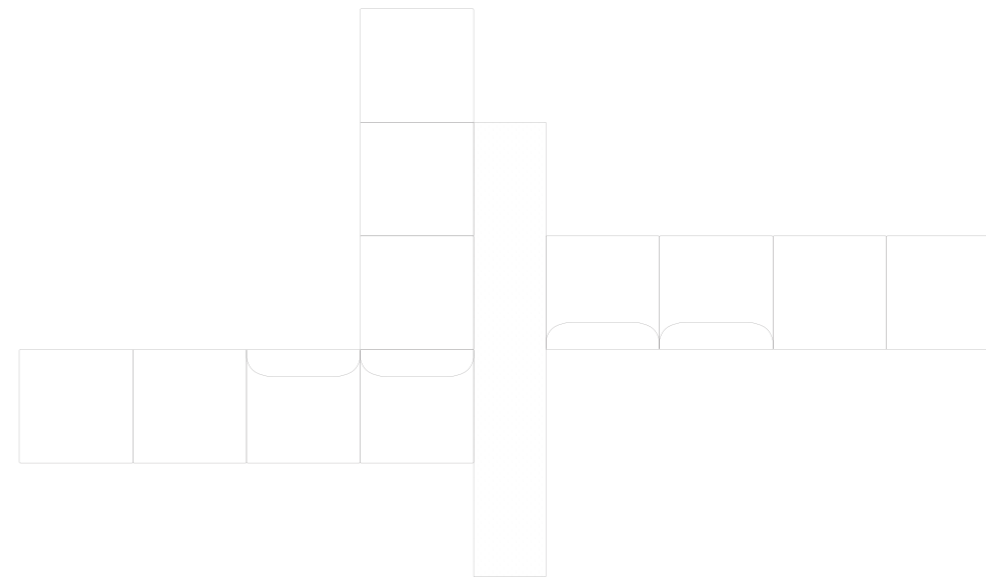

- 2 x Art. 6300 – Structure S252
- 1 x Art. 6301 – Structure S189
- 7 x Art. 6303 – Cushion
- 4 x Art. 6304 – Cushion with backrest
- 1 x Art. 6305 – Console h 58 cm
- 1 x Art. 6316 – Plate-shaped link





- 2 x Art. 6300 – Structure S252
- 8 x Art. 6304 – Cushion with backrest
- 1 x Art. 6306 – Console h 72 cm

- 1 x Art. 6300 – Structure S252
- 1 x Art. 6302 – Structure S126
- 4 x Art. 6304 – Cushion with backrest
- 1 x Art. 6310 – Rectangular table 126x63 cm
- 1 x Art. 6307 – Console h 105 cm
- 1 x Art. 6313 – Ottoman
- 1 x Art. 6316 – Plate-shaped link

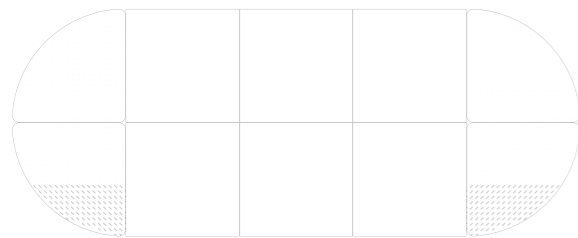

- 2 x Art. 6300 – Structure S252
- 6 x Art. 6303 – Cushion
- 4 x Art. 6311 – 1/4 circle table 63x63 cm
- 2 x Art. 6315 – Island-shaped link
- 2 x Art. 6316 – Plate-shaped link

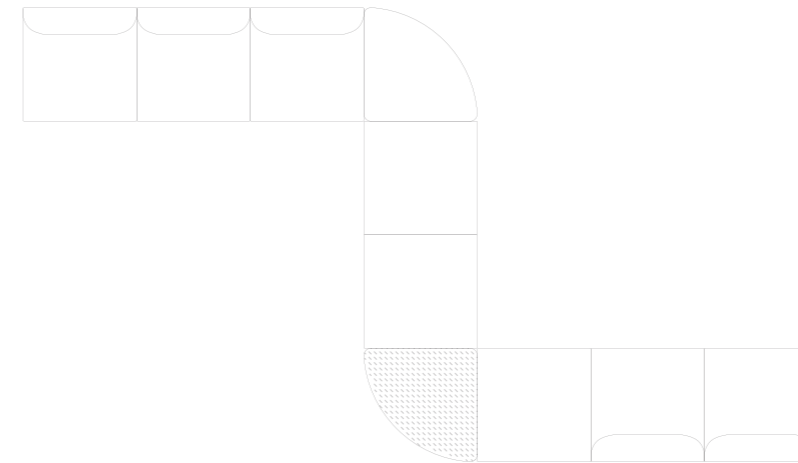

- 2 x Art. 6301 – Structure S189
- 1 x Art. 6302 – Structure S126
- 3 x Art. 6303 – Cushion
- 5 x Art. 6304 – Cushion with backrest
- 2 x Art. 6311 – 1/4 circle table 63x63 cm
- 4 x Art. 6314 – C-shaped link

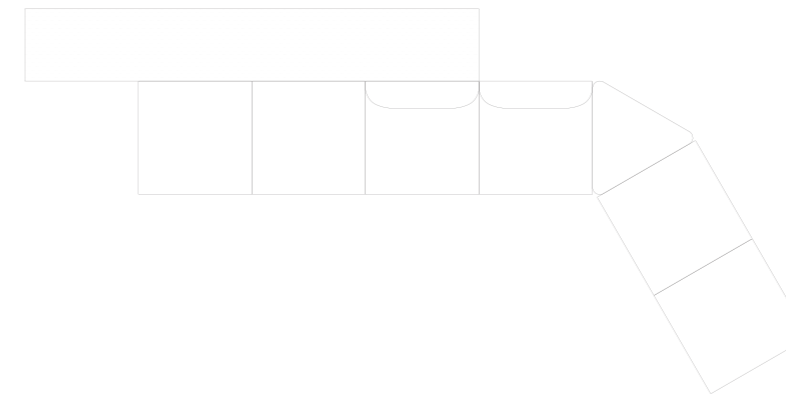

- 1 x Art. 6300 – Structure S252
- 1 x Art. 6302 – Structure S126
- 4 x Art. 6303 – Cushion
- 2 x Art. 6304 – Cushion with backrest
- 1 x Art. 6312 – Triangular table 63x63x63 cm
- 3 x Art. 6316 – Plate-shaped link
- 1 x Art. 6305 – Console h 58 cm

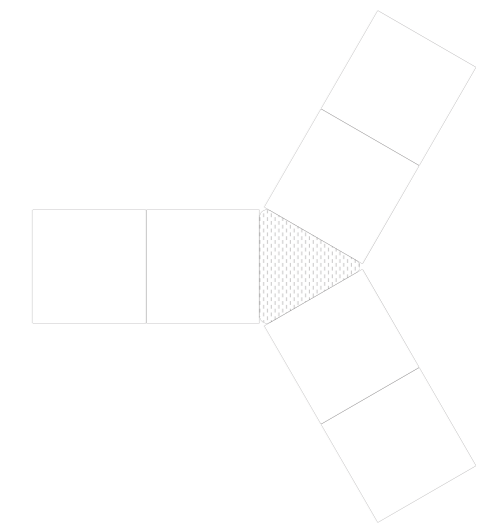

- 3 x Art. 6302 – Structure S126
- 6 x Art. 6303 – Cushion
- 1 x Art. 6312 – Triangular table 63x63x63 cm
- 3 x Art. 6316 – Plate-shaped link



Collection overview

Chair

Low backrest



Chair with a 5 way base mounted on castors with a polypropylene backrest, front face mesh and upholstered seat

Chair with a 5 way base mounted on castors, entirely upholstered seat and backrest

High backrest



Chair with a 5 way base mounted on castors with a polypropylene backrest, front face mesh and upholstered seat

Chair with a 5 way base mounted on castors, entirely upholstered seat and backrest

Stool

Low backrest



Stool with a 5 way base mounted on feet, polypropylene backrest, front face mesh and upholstered seat

Stool with a 5 way base mounted on feet, entirely upholstered seat and backrest

Stool with a 5 way base mounted on castors, polypropylene backrest, front face mesh and upholstered seat

Stool with a 5 way base mounted on castors, entirely upholstered seat and backrest

Armrest types



Width 10 cm

Width 14 cm

Mechanism



"Built-in self-tensioning weight response mechanism with:

- (A) backrest with 5-position recline
- (B) Up&down of the backrest with 5-position recline and built-in lumbar support.
- (C) Sliding seat with 5-position adjustment
- (D) Sliding armrests with 5-position adjustment"

Armrest movement  
It slides to the right and to the left

Instructions for modular arrangements

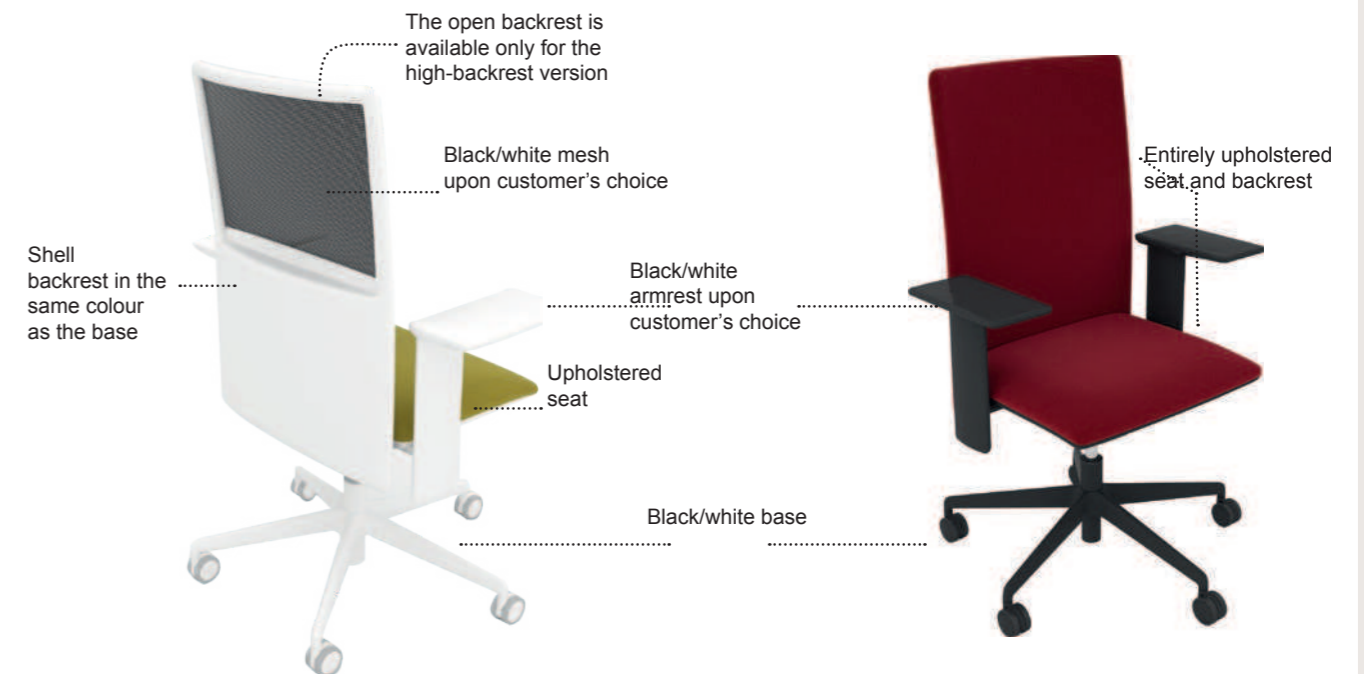



Collection overview

Type



Polypropylene chair mounted on castors

Polypropylene chair mounted on castors, with seat cushion

Polypropylene armchair mounted on castors

Polypropylene armchair mounted on castors, with seat cushion

Stool with castors

Shell

Chair version

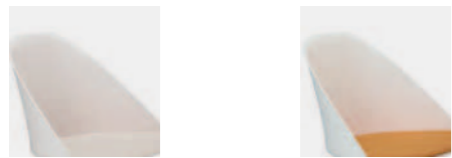

Polypropylene

Polypropylene with seat cushion

Armchair version

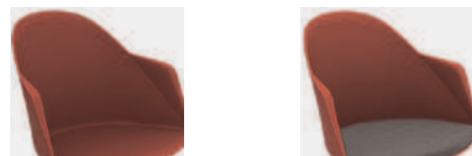

Polypropylene

Polypropylene with seat cushion

Accessories



Writing tablet 50x33,5 cm

Movement on castors



All versions of Cila Go (chair, armchair, and stool) are mounted on castors to ease movement.

Type



Chair on a 5 way reinforced nylon fibre swivel base

Chair on a 5 way reinforced nylon fibre swivel base + writing tablet

Armchair on a 5 way reinforced nylon fibre swivel base

Armchair on a 5 way reinforced nylon fibre swivel base + writing tablet

Shell

Chair version



Polypropylene

Polypropylene with seat cushion

Upholstered with non-removable cover

Armchair version



Polypropylene

Polypropylene with seat cushion

Upholstered with non-removable cover



Collection overview

Bases



Sled base without armrests

Sled with armrests

Shells



Polypropylene seat and backrest

Upholstered seat and polypropylene backrest

Seat and backrest upholstered in one-colour

Options



Anti-panic writing tablet — only available for chromed sled

Row spacer

Chair linking system

Numbers for chairs and lines

Instructions for modular arrangements

Two-colour polypropylene versions Armrest layout



Polypropylene seat and backrest are available in a two colour version, with black seat and backrest in one of the other four colours available

Polypropylene seat and backrest: polypropylene armrests come in the same colour as the seat

Upholstered seat and polypropylene backrest: the polypropylene armrest pad comes in the same colour as the backrest

Upholstered seat and backrest: the polypropylene armrest pad is available in 5 colours

Stackability

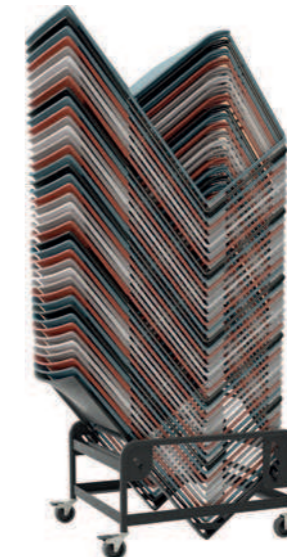

Glides color

Chromed bases: black glides.  
Powdercoated bases: glides in the same color of the base

Upholstered versions: transparent stacking glides



Trolley for writing tablet



Trolley

**Max 40 pcs**  
For the polypropylene version with no armrests  
**Max 25 pcs**  
For all other versions







## Contacts

### Italy

Monastier (TV) — Headquarters and showroom  
Arper SPA  
Via Lombardia 16  
31050 Monastier di Treviso (TV)  
T +39 0422 7918  
F +39 0422 791800  
info@arper.com  
www.arper.com

Commerciale Italia  
T +39 0422 791905  
F +39 0422 791900  
commerciale@arper.com

Export Office  
sales@arper.com

Milan — Showroom  
Via Pantano 30  
20122 Milan  
T +39 02 89093865  
milano@arper.com

### **EUROPE**

#### UK

London — Subsidiary and showroom  
Arper UK LTD  
11 Clerkenwell Road  
London EC1M 5PA  
T +44 (0) 20 7253 0009  
london@arper.com

#### Belgium

Beernem — Branch and Meeting Hub  
Sint-Jorisstraat 82,  
8730 Beernem  
T +32 50 705960  
belgium@arper.com

#### Germany

Cologne — Showroom  
Design Post Köln  
Deutz-Mülheimer-Str. 22a  
50679 Köln  
T +49 221 690 650  
info@designpost.de

Fruchtof München — Meeting Hub  
2. Innenhof, 2. Etage  
Gotzinger Straße 52b  
D-81371 München  
T +49 171 5548178  
muenchen@arper.com

#### Norway

Oslo — Showroom  
Drammensveien 130  
0277 Oslo  
T +47 908 202226  
norway@arper.com

### Sweden

Stockholm — Branch  
T +46 705 101216  
sweden@arper.com

### The Netherlands

Amsterdam — Showroom  
Design Post  
Cruquiusweg 111-P  
1019 AG Amsterdam  
T +31 (0)20 705 1555  
showroom@beltane.nl

### **AMERICA**

#### USA

New York — Subsidiary and showroom  
Arper USA Inc.  
476 Broadway, Suite 2F  
NY 10013 New York  
T +1 (212) 647 8900  
infousa@arper.com

Chicago — Showroom  
The Merchandise Mart  
Space#346 - 3rd Floor  
Chicago  
T +1 (336) 434 2366  
infousa@arper.com

High Point, North Carolina — Production and logistics site  
660 Southwest St  
High Point, NC 27260  
T +1 (336) 434 2370  
F +1 (212) 647 8912  
infousa@arper.com

Los Angeles — Showroom  
550 South Hope St., Suite 275  
90071 Los Angeles  
T +1 (336) 434 2382  
infousa@arper.com

#### Mexico

Mexico City — Subsidiary and showroom  
Culiacan 123, Piso 9  
Col. Hipodromo Condesa  
Delegation Cuauhtémoc  
06170 – Ciudad de México  
Mexico  
T +52 1 62714417  
T +52 1 62714419  
infolatam@arper.com

### **ASIA**

#### Japan

Arper Japan K.K. — Subsidiary and showroom  
HT Jingu Gaien Bldg.8F  
Minato-ku Kita-Aoyama 2-7-22  
Tokyo 107-0061  
T +81 3 5775 0008  
F +81 3 5775 0009  
carejpn@arper.com

#### China

Shanghai — Subsidiary  
爱尔派 (上海) 家具设计有限公司  
Shanghai - China  
china@arper.com

#### Singapore

Singapore — Branch  
singapore@arper.com

#### UAE

Arper Middle East — Subsidiary and showroom  
U-Bora Towers - Unit 1901  
Business Bay  
Dubai  
T +971 509144800  
infome@arper.com

**arper**



arper