

MORELATO

E B A N I S T E R I A I T A L I A N A

catalogo tecnico
technical catalog

— 23

vol.3

MORELATO

E B A N I S T E R I A I T A L I A N A

catalogo tecnico
technical catalog

— 23

vol.3

SOMMARIO

CONTENTS

3	LIBRERIE A SPALLA BOOKCASES	153	DIVANI POLTRONE DORMEUSE DIVANI-LETTO SOFAS ARMCHAIRS DORMEUSE SOFA-BEDS
27	MODULI componibili WALL-UNITS		
89	LIBRERIE DESIGN LIBRARIES	163	LETTI BEDS
95	CREDENZE CABINETS	171	COMÒ COMODINI CASSETTIERE COMÒ BEDSIDE TABLES CHEST OF DRAWERS
107	TAVOLI TABLES		
115	SCRIVANIE WRITING-DESKS	183	CABINE ARMADIO WARDROBE CABINS
121	SEDIE POLTRONCINE POLTRONCINE GIREVOLI SGABELLI CHAIRS ARMCHAIRS SWIVEL CHAIRS STOOLS	193	ARMADI WARDROBES
		201	ACCESSORI ACCESSORIES
141	COMPLEMENTI TAVOLINI SPECCHI COMPLEMENTS COFFEE TABLES MIRRORS	203	FINITURE TESSUTI FINISHING FABRICS
		220	INDICE DEGLI ARTICOLI INDEX OF ARTICLES

LIBRERIE
BIBLIOTECHE
BOOKCASES



ART. FS3510597
COMPOSIZIONE MASCHERA SCORREVOLE

CUSTOMIZABLE

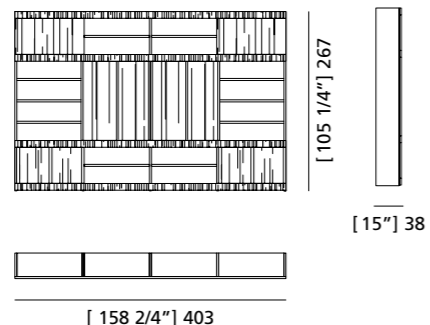

MISURE: L 403 P 38 H 267
DESCRIZIONE: proposta di libreria Maschera componibile a 4 elementi. Struttura interna a giorno in legno di ciliegio e ripiani regolabili; ante scorrevoli in frassino di due misure. Su richiesta ante in essenza di Acero, Wengè, Ebano Makassar, Padouk, Ciliegio, Rovere.
Design Centro Ricerche MAMM
PESO: 320 kg - m³: 2 COLLI: 16
MEASURES: L 403 W 38 H 267
DESCRIPTION: proposal for a modular Mask bookcase. Internal 4-elements open structure made of cherry wood with adjustable shelves, 2 big sliding doors and 4 small sliding doors made of ash wood. Upon request: doors veneered in Maple, Wenge, Macassar Ebony, Padouk, Cherry, Oak.
Design by Centro Ricerche MAMM
WEIGHT: 320 kg - m³: 2 PIECES: 16

ART. FS3510598
COMPOSIZIONE MASCHERA SCORREVOLE

CUSTOMIZABLE

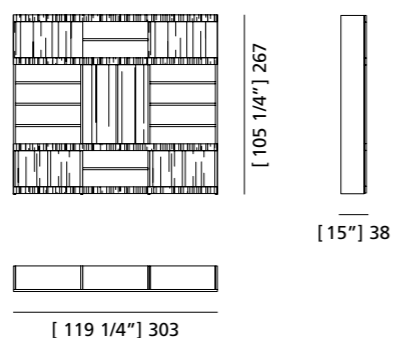

MISURE: L 303 P 38 H 267
DESCRIZIONE: proposta di libreria Maschera componibile a 3 elementi. Struttura interna a giorno in legno di ciliegio e ripiani regolabili; ante scorrevoli in frassino di due misure. Su richiesta ante in essenza di Acero, Wengè, Ebano Makassar, Padouk, Ciliegio, Rovere.
Design Centro Ricerche MAMM
PESO: 250 kg - m³: 1,2 COLLI: 13
MEASURES: L 303 W 38 H 267
DESCRIPTION: proposal for a modular Mask bookcase. Internal 3-elements open structure made of cherry wood with adjustable shelves, 1 big sliding door and 4 small sliding doors made of ash wood. Upon request: doors veneered in Maple, Wenge, Macassar Ebony, Padouk, Cherry, Oak.
Design by Centro Ricerche MAMM
WEIGHT: 250 kg - m³: 1,2 PIECES: 13

ART. FS3510599
COMPOSIZIONE MASCHERA SCORREVOLE

CUSTOMIZABLE

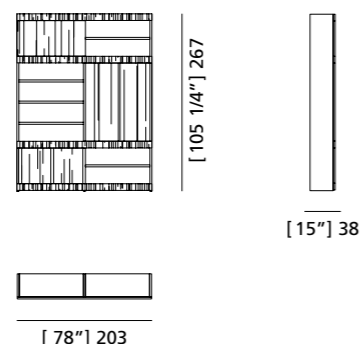

MISURE: L 203 P 38 H 267
DESCRIZIONE: proposta di libreria Maschera componibile a 2 elementi. Struttura interna a giorno in legno di ciliegio e ripiani regolabili; ante scorrevoli in frassino di due misure. Su richiesta ante in essenza di Acero, Wengè, Ebano Makassar, Padouk, Ciliegio, Rovere.
Design Centro Ricerche MAMM
PESO: 170 kg - m³: 0,7 COLLI: 10
MEASURES: L 203 W 38 H 267
DESCRIPTION: proposal for a modular Mask bookcase. Internal 2-elements open structure made of cherry wood with adjustable shelves, 1 big sliding door and 2 small sliding doors made of ash wood. Upon request: doors veneered in Maple, Wenge, Macassar Ebony, Padouk, Cherry, Oak.
Design by Centro Ricerche MAMM
WEIGHT: 170 kg - m³: 0,7 PIECES: 10

ART. 3537
COMPOSIZIONE MASCHERA

CUSTOMIZABLE

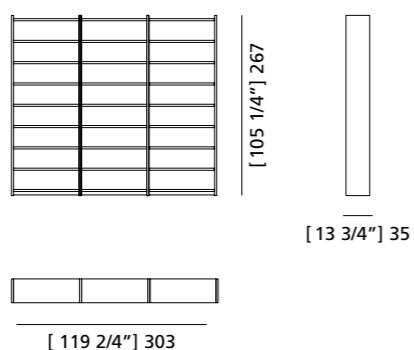

MISURE: L 303 P 35 H 267
DESCRIZIONE: proposta di Libreria componibile con struttura a giorno in legno di ciliegio di spessore 3cm per composizioni Maschera Scorrevole o Maschera con ante a battente. Ripiani regolabili. Finitura: F30.
Design Centro Ricerche MAMM
PESO: 175 kg - m³: 0,9 COLLI: 10
MEASURES: L 303 W 35 H 267
DESCRIPTION: modular open bookcase made of cherry wood of 3 cm thickness for Mask compositions with sliding or hinged doors. Adjustable shelves. Finishing: F30.
Design by Centro Ricerche MAMM
WEIGHT: 175 kg - m³: 0,9 PIECES: 10

ART. 3582/F
ANTA SCORREVOLE MASCHERA 2/4

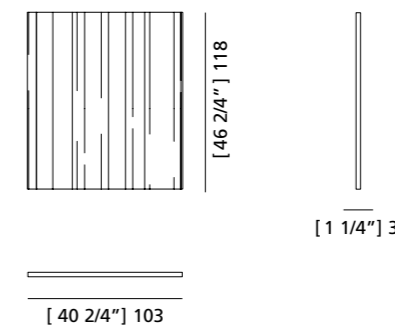

MISURE: L 103 P 3 H 118
DESCRIZIONE: anta scorrevole per composizione Maschera in frassino da applicare su elemento Fascia 3583. Su richiesta ante in essenza di Acero, Wengè, Ebano Makassar, Padouk, Ciliegio, Rovere.
Design Centro Ricerche MAMM
PESO: 10 kg - m³: 0,06 COLLI: 1
MEASURES: L 103 W 3 H 118
DESCRIPTION: sliding door in ash wood for Mask composition to be applied on item 3583. Upon request made of Maple, Wenge, Macassar Ebony, Padouk, Cherry, Oak.
Design by Centro Ricerche MAMM
WEIGHT: 10 kg - m³: 0,06 - PIECES: 1

ART. 3581/F
ANTA SCORREVOLE MASCHERA 1/4

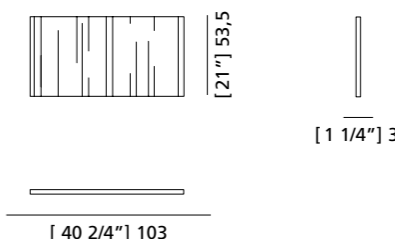

MISURE: L 103 P 3 H 53,5
DESCRIZIONE: anta scorrevole per composizione Maschera in frassino da applicare su elemento Fascia 3583. Su richiesta ante in essenza di Acero, Wengè, Ebano Makassar, Padouk, Ciliegio, Rovere.
Design Centro Ricerche MAMM
PESO: 6 kg - m³: 0,02 - COLLI: 1
MEASURES: L 103 W 3 H 53,5
DESCRIPTION: sliding door in ash wood for Mask composition to be applied on item 3583. Upon request made of Maple, Wenge, Macassar Ebony, Padouk, Cherry, Oak.
Design by Centro Ricerche MAMM
WEIGHT: 6 kg - m³: 0,02 - PIECES: 1

ART. 3583/F
FASCIA MASCHERA SCORREVOLE

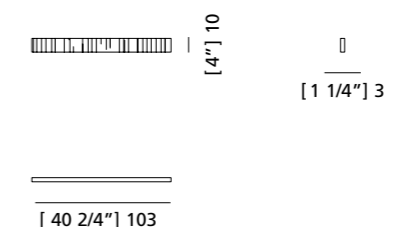

MISURE: L 103 P 3 H 10
DESCRIZIONE: fascia di chiusura in frassino per composizione Maschera, con corsia metallica per ante scorrevole.
Design Centro Ricerche MAMM
PESO: 2 kg - m³: 0,01 COLLI: 1
MEASURES: L 103 W 3 H 10
DESCRIPTION: closing band in ash wood for Mask composition, with metal rail for sliding doors.
Design by Centro Ricerche MAMM
WEIGHT: 2 kg - m³: 0,01 PIECES: 1

ART.3345
ELEMENTO SCALA

ART. A0101805
BARRA TUBOLARE AL MTL.L

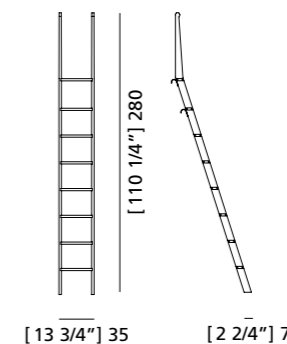

MISURE: L 35 P 7 H 280
DESCRIZIONE: elemento scala per composizioni a doppia altezza.
PESO: 8 kg - m³: 0,02 COLLI: 1
MEASURES: L 35 P 7 H 280
DESCRIPTION: ladder for compositions with double height.
WEIGHT: 8 kg - m³: 0,02 PIECES: 1

ART. 3535
MASCHERA A GIORNO

CUSTOMIZABLE

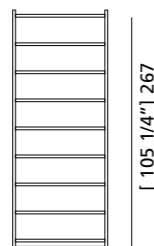

[105 1/4"] 267



[40 2/4"] 103



[13 3/4"] 35

MISURE: L 103 P 35 H 267
DESCRIZIONE: elemento componibile singolo in legno di ciliegio per libreria Maschera Scorrevole o con anta battente. Struttura a spalla con 7 ripiani regolabili.
PESO: 62 kg - m³: 0,30
COLLI: 5

MEASURES: L 103 W 35 H 267
DESCRIPTION: single modular open bookcase made of cherry wood of 3 cm thickness for Mask compositions with sliding or hinged doors. Adjustable shelves.
WEIGHT: 62 kg - m³: 0,30
PIECES: 5

ART. 3538
MASCHERA A GIORNO

CUSTOMIZABLE

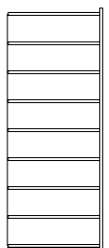

[105 1/4"] 267

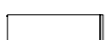

[39 2/4"] 100



[13 3/4"] 35

MISURE: L 100 P 35 H 267
DESCRIZIONE: elemento componibile aggiuntivo in legno di ciliegio per art. 3535 libreria Maschera. Struttura a spalla con 7 ripiani regolabili.
PESO: 50 kg - m³: 0,25
COLLI: 5

MEASURES: L 100 W 35 H 267
DESCRIPTION: single additional modular open bookcase made of cherry wood of 3 cm thickness for Mask compositions art. 3535 with sliding or hinged doors. Adjustable shelves.
WEIGHT: 50 kg - m³: 0,25
PIECES: 5



ART. 3541/F
COMPOSIZIONE MASCHERA

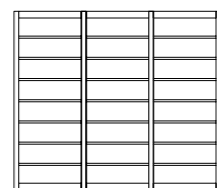

[105 1/4"] 267

[14 3/4"] 38

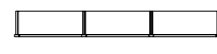

[120 3/4"] 307

MISURE: L 307 P 38 H 267
DESCRIZIONE: libreria a giorno in legno di frassino formata da 3 moduli con ripiani interni regolabili in altezza.
Design Sophia Los
PESO: 186 kg - m³: 3,2
COLLI: 15

MEASURES: L 307 W 38 H 267
DESCRIPTION: open bookcase in ash wood made of 3 modules with height adjustable internal shelves.
Design by Sophia Los
WEIGHT: 186 kg - m³: 3,2
PIECES: 15

ART. 3541
COMPOSIZIONE MASCHERA

CUSTOMIZABLE

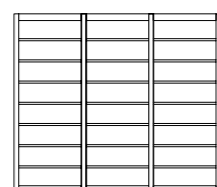

[105 1/4"] 267

[14 3/4"] 38

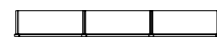

[120 3/4"] 307

MISURE: L 307 P 38 H 267
DESCRIZIONE: proposta di Libreria Maschera componibile con struttura a 3 vani a giorno in legno di ciliegio, ripiani regolabili e cornice di chiusura.
PESO: 186 kg - m³: 3,2
COLLI: 15

MEASURES: L 307 W 38 H 267
DESCRIPTION: proposal for Mask modular bookcase made of cherry wood with adjustable shelves and decorated frame.
WEIGHT: 186 kg - m³: 3,2
PIECES: 15

ART. FS3510177
COMPOSIZIONE MASCHERA

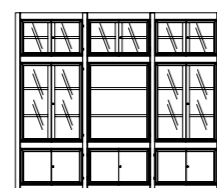

[105 1/4"] 267

[15 2/4"] 39,5



[120 3/4"] 307

MISURE: L 307 P 39,5 H 267
DESCRIZIONE: proposta di Libreria Maschera componibile con struttura a 3 vani, ripiani regolabili e cornice di chiusura con ante a battente: 3 in legno e 5 in vetro. Elemento centrale a giorno.
PESO: 265 kg - m³: 1
COLLI: 11

MEASURES: L 307 W 39,5 H 267
DESCRIPTION: maschera wall unit composed of three elements, frame and doors made of cherry wood. Three wooden doors and 5 glass doors. Internal shelves are adjustable.
WEIGHT: 265 kg - m³: 1
PIECES: 11

ART. FS3510178
COMPOSIZIONE MASCHERA

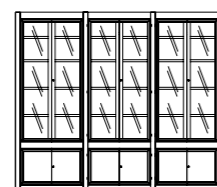

[105 1/4"] 267

[15 2/4"] 39,5

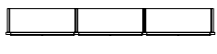

[120 3/4"] 307

MISURE: L 307 P 39,5 H 267
DESCRIZIONE: proposta di Libreria Maschera componibile con struttura a 3 vani, ripiani regolabili e cornice di chiusura con ante a battente: 3 in legno e 3 in vetro.
PESO: 280 kg - m³: 1
COLLI: 10

MEASURES: L 307 W 39,5 H 267
DESCRIPTION: proposal for Mask modular bookcase with 3 compartments, adjustable shelves and frame with hinged doors: 3 wooden and 3 big glass doors.
WEIGHT: 280 kg - m³: 1
PIECES: 10

ART. 3537
COMPOSIZIONE MASCHERA

CUSTOMIZABLE

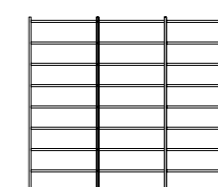

[105 1/4"] 267

[13 3/4"] 35

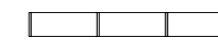

[119 2/4"] 303

MISURE: L 303 P 35 H 267
DESCRIZIONE: proposta di Libreria componibile con struttura a giorno in legno di ciliegio di spessore 3cm per composizioni Maschera Scorrevole o Maschera con ante a battente.
PESO: 175 kg - m³: 0,9
COLLI: 10

MEASURES: L 303 W 35 H 267
DESCRIPTION: modular open bookcase made of cherry wood of 3 cm thickness for Mask compositions with sliding or hinged doors.
WEIGHT: 175 kg - m³: 0,9
PIECES: 10

ART. 3535
MASCHERA A GIORNO

CUSTOMIZABLE



[105 1/4"] 267

[13 3/4"] 35

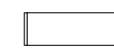

[40 2/4"] 103

MISURE: L 103 P 35 H 267
DESCRIZIONE: elemento componibile singolo in legno di ciliegio per libreria Maschera Scorrevole o con ante battente. Struttura a spalla con 7 ripiani regolabili.
PESO: 62 kg - m³: 0,30
COLLI: 5

MEASURES: L 103 W 35 H 267
DESCRIPTION: single modular open bookcase made of cherry wood of 3 cm thickness for Mask compositions with sliding or hinged doors.
WEIGHT: 62 kg - m³: 0,30
PIECES: 5

ART. 3538
MASCHERA A GIORNO

CUSTOMIZABLE



[105 1/4"] 267

[13 3/4"] 35

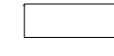

[39 2/4"] 100

MISURE: L 100 P 35 H 267
DESCRIZIONE: elemento componibile aggiuntivo in legno di ciliegio per art. 3535 libreria Maschera.
PESO: 50 kg - m³: 0,25
COLLI: 5

MEASURES: L 100 W 35 H 267
DESCRIPTION: single additional modular open bookcase made of cherry wood of 3 cm thickness for Mask compositions art. 3535 with sliding or hinged doors.
WEIGHT: 50 kg - m³: 0,25
PIECES: 5

ART. 3565/F
CORNICE MASCHERA



[105 1/4"] 267

[1 1/4"] 3

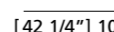

[42 1/4"] 107

MISURE: L 107 P 3 H 267
DESCRIZIONE: cornice o fascia di chiusura in legno di frassino per libreria Maschera componibile a giorno o con ante 3558, 3559.
PESO: 8 kg - m³: 0,10
COLLI: 1

MEASURES: L 107 W 3 H 267
DESCRIPTION: decorating frame made of ash wood for Mask open bookcase or with doors 3558, 3559.
WEIGHT: 8 kg - m³: 0,10
PIECES: 1

ART. 3566/F
CORNICE MASCHERA

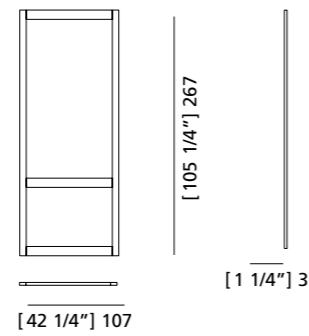

MISURE: L 107 P 3 H 267
DESCRIZIONE: cornice o fascia di chiusura in legno di frassino per libreria Maschera componibile a giorno o con anta 3552, 3556, 3553, 3557.
PESO: 9,5 kg - m³: 0,10
COLLI: 1

MEASURES: L 107 W 3 H 267
DESCRIPTION: frame made of ash wood for Mask open bookcase or with doors 3552, 3556, 3553, 3557.
WEIGHT: 9,5 kg - m³: 0,10
PIECES: 1

ART. 3567/F
CORNICE MASCHERA

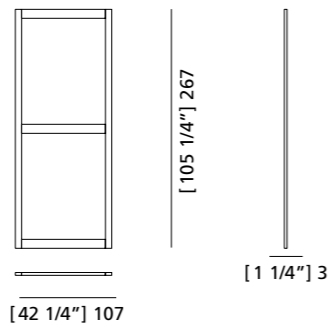

MISURE: L 107 P 3 H 267
DESCRIZIONE: cornice o fascia di chiusura in legno di frassino per libreria Maschera componibile a giorno o con anta 3554, 3555.
PESO: 9,5 kg - m³: 0,10
COLLI: 1

MEASURES: L 107 W 3 H 267
DESCRIPTION: frame made of ash wood for Mask open bookcase or with doors 3554, 3555.
WEIGHT: 9,5 kg - m³: 0,10
PIECES: 1

ART. 3568/F
CORNICE MASCHERA

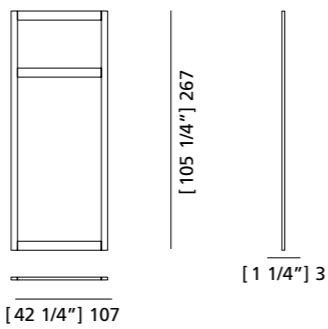

MISURE: L 107 P 3 H 267
DESCRIZIONE: cornice o fascia di chiusura in legno di frassino per libreria Maschera componibile a giorno o con anta 3552, 3556, 3553, 3557.
PESO: 9,5 kg - m³: 0,10
COLLI: 1

MEASURES: L 107 W 3 H 267
DESCRIPTION: frame made of ash wood for Mask open bookcase or with doors 3552, 3556, 3553, 3557.
WEIGHT: 9,5 kg - m³: 0,10
PIECES: 1

ART. 3569/F
CORNICE MASCHERA

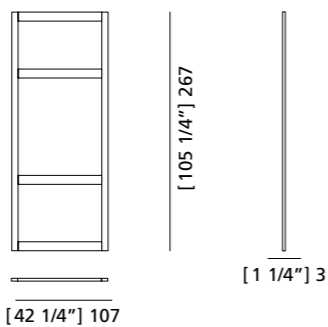

MISURE: L 107 P 3 H 267
DESCRIZIONE: cornice o fascia di chiusura in legno di frassino per libreria Maschera componibile a giorno o con anta 3552, 3554, 3553, 3555.
PESO: 11 kg - m³: 0,10
COLLI: 1

MEASURES: L 107 W 3 H 267
DESCRIPTION: frame made of ash wood for Mask open bookcase or with doors 3552, 3554, 3553, 3555.
WEIGHT: 11 kg - m³: 0,10
PIECES: 1

ART. 3552/F
COPPIA ANTE LEGNO MASCHERA

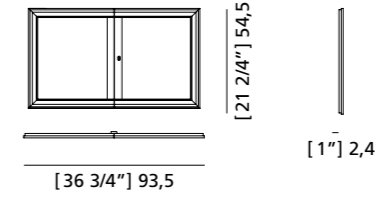

MISURE: L 93,5 P 2,4 H 54,5
DESCRIZIONE: coppia di ante in legno di frassino per Libreria Maschera componibile, da applicare all'elemento cornice.
PESO: 6 kg - m³: 0,02
COLLI: 1

MEASURES: L 93,5 W 2,4 H 54,5
DESCRIPTION: pair of doors made of ash wood for mask bookcase, to apply to the frame.
WEIGHT: 6 kg - m³: 0,02
PIECES: 1

ART. 3554/F
COPPIA ANTE LEGNO MASCHERA

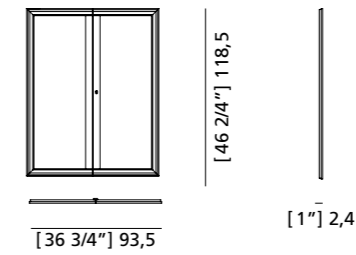

MISURE: L 93,5 P 2,4 H 118,5
DESCRIZIONE: coppia di ante in legno di frassino per Libreria Maschera componibile, da applicare all'elemento cornice.
PESO: 13 kg - m³: 0,06
COLLI: 1

MEASURES: L 93,5 W 2,4 H 118,5
DESCRIPTION: pair of doors made of ash wood for Mask bookcase, to apply to the frame.
WEIGHT: 13 kg - m³: 0,06
PIECES: 1

ART. 3556/F
COPPIA ANTE LEGNO MASCHERA

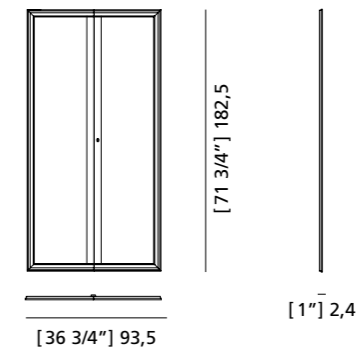

MISURE: L 93,5 P 2,4 H 182,5
DESCRIZIONE: coppia di ante in legno di frassino per Libreria Maschera componibile, da applicare all'elemento cornice.
PESO: 20 kg - m³: 0,1
COLLI: 1

MEASURES: L 93,5 W 2,4 H 182,5
DESCRIPTION: Pair of doors made of ash wood for Mask bookcase, to apply to the frame.
WEIGHT: 20 kg - m³: 0,1
PIECES: 1

ART. 3558/F
COPPIA ANTE LEGNO MASCHERA

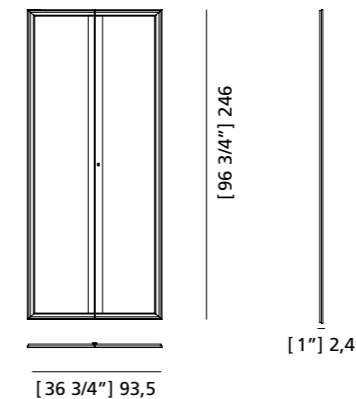

MISURE: L 93,5 P 2,4 H 246
DESCRIZIONE: coppia di ante in legno di frassino per Libreria Maschera componibile, da applicare all'elemento cornice.
PESO: 28 kg - m³: 0,15
COLLI: 1

MEASURES: L 93,5 W 2,4 H 246
DESCRIPTION: pair of doors made of ash wood for Mask bookcase, to apply to the frame.
WEIGHT: 28 kg - m³: 0,15
PIECES: 1

ART. 3553/F
COPPIA ANTE VETRO MASCHERA



[36 3/4"] 93,5

[21 2/4"] 54,5

[1"] 2,4

MISURE: L 93,5 P 2,4 H 54,5
DESCRIZIONE: coppia di ante in vetro temperato con struttura in frassino per Libreria Maschera componibile, da applicare all'elemento cornice.
PESO: 6 kg - m³: 0,02
COLLI: 1

MEASURES: L 93,5 W 2,4 H 54,5
DESCRIPTION: pair of glass doors with ash wood frame for Mask bookcase, to apply to the frame.
WEIGHT: 6 kg - m³: 0,02
PIECES: 1

ART. 3555/F
COPPIA ANTE VETRO MASCHERA

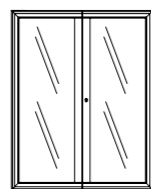

[36 3/4"] 93,5

[46 2/4"] 118,5

[1"] 2,4

MISURE: L 93,5 P 2,4 H 118,5
DESCRIZIONE: coppia di ante in vetro temperato con struttura in frassino per Libreria Maschera componibile, da applicare all'elemento cornice.
PESO: 13 kg - m³: 0,06
COLLI: 1

MEASURES: L 93,5 W 2,4 H 118,5
DESCRIPTION: pair of glass doors with ash wood frame for Mask bookcase, to apply to the frame.
WEIGHT: 13 kg - m³: 0,06
PIECES: 1

ART. 3557/F
COPPIA ANTE VETRO MASCHERA

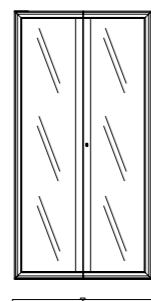

[36 3/4"] 93,5

[71 3/4"] 182,5

[1"] 2,4

MISURE: L 93,5 P 2,4 H 182,5
DESCRIZIONE: coppia di ante in vetro temperato con struttura in frassino per Libreria Maschera componibile, da applicare all'elemento cornice.
PESO: 20 kg - m³: 0,1
COLLI: 1

MEASURES: L 93,5 W 2,4 H 182,5
DESCRIPTION: Pair of glass doors with ash wood frame for Mask bookcase, to apply to the frame.
WEIGHT: 20 kg - m³: 0,1
PIECES: 1

ART. 3559/F
COPPIA ANTE VETRO MASCHERA

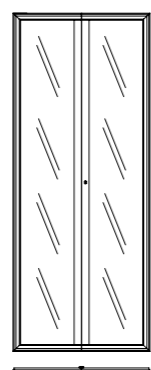

[36 3/4"] 93,5

[96 3/4"] 246

[1"] 2,4

MISURE: L 93,5 P 2,4 H 246
DESCRIZIONE: coppia di ante in vetro temperato con struttura in frassino per Libreria Maschera componibile, da applicare all'elemento cornice.
PESO: 28 kg - m³: 0,15
COLLI: 1

MEASURES: L 93,5 P 2,4 H 246
DESCRIPTION: pair of glass doors with ash wood frame for Mask bookcase, to apply to the frame.
WEIGHT: 28 kg - m³: 0,15
PIECES: 1

ART. 3570/F
CORNICE SAGOMATA

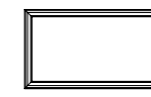

[36 3/4"] 93,5

[21 2/4"] 54,5

[1"] 2,4

MISURE: L 93,5 P 2,4 H 54,5
DESCRIZIONE: cornice in legno di frassino per 1/4 di vano a giorno.
PESO: 2 kg - m³: 0,02
COLLI: 1

MEASURES: L 93,5 P 2,4 H 54,5
DESCRIPTION: Frame made of ash wood for open element.
WEIGHT: 2 kg - m³: 0,02
PIECES: 1

ART. 3571/F
CORNICE SAGOMATA

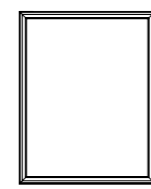

[36 3/4"] 93,5

[46 2/4"] 118,5

[1"] 2,4

MISURE: L 93,5 P 2,4 H 118,5
DESCRIZIONE: cornice in legno di frassino per 2/4 di vano a giorno.
PESO: 3 kg - m³: 0,02
COLLI: 1

MEASURES: L 93,5 P 2,4 H 118,5
DESCRIPTION: frame made of ash wood for open element.
WEIGHT: 3 kg - m³: 0,02
PIECES: 1

ART. 3572/F
CORNICE SAGOMATA

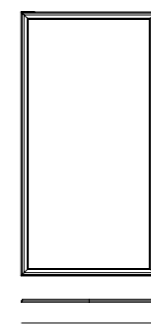

[36 3/4"] 93,5

[71 3/4"] 182,5

[1"] 2,4

MISURE: L 93,5 P 2,4 H 182,5
DESCRIZIONE: cornice in legno di frassino per 3/4 di vano a giorno.
PESO: 5 kg - m³: 0,04
COLLI: 1

MEASURES: L 93,5 P 2,4 H 182,5
DESCRIPTION: frame made of ash wood for open element.
WEIGHT: 5 kg - m³: 0,04
PIECES: 1

ART. 3573/F
CORNICE SAGOMATA

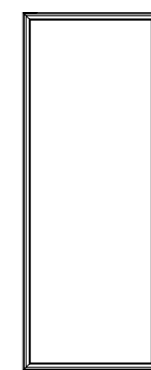

[36 3/4"] 93,5

[96 3/4"] 246

[1"] 2,4

MISURE: L 93,5 P 2,4 H 246
DESCRIZIONE: cornice in legno di frassino per 4/4 di vano a giorno.
PESO: 7 kg - m³: 0,05
COLLI: 1

MEASURES: L 93,5 P 2,4 H 246
DESCRIPTION: frame made of ash wood for open element.
WEIGHT: 7 kg - m³: 0,05
PIECES: 1

ART. 3560/F
CORNICE SAGOMATA



MISURE: L a misura
DESCRIZIONE: cornice sagomata su misura in legno di frassino per Libreria Maschera componibile.

MEASURES: L to measure
DESCRIPTION: shaped frame made of ash wood for open element.

ART. 3517/F
CORNICE MASCHERA

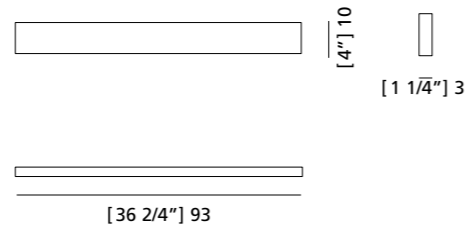

MISURE: L 93 P 3 H 10
DESCRIZIONE: fascia di chiusura su misura in legno di frassino per Libreria Maschera componibile.
PESO: 2 kg - m³: 0,01
COLLI: 1

MEASURES: L 93 W 3 H 10
DESCRIPTION: shaped frame made of ash wood for open element.
WEIGHT: 2 kg - m³: 0,01
PIECES: 1

ART. 3514
RIPIANO

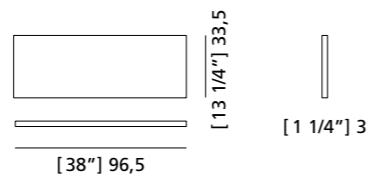

MISURE: L 96,5 P 33,5 H 3
DESCRIZIONE: ripiano in legno di ciliegio per Libreria Maschera componibile.
PESO: 5,5 kg - m³: 0,01
COLLI: 1

MEASURES: L 96,5 P 33,5 H 3
DESCRIPTION: shelf for Mask modular bookcase.
WEIGHT: 5,5 kg - m³: 0,01
PIECES: 1



ART. FS3411047
LIBRERIA SHARK

CUSTOMIZABLE

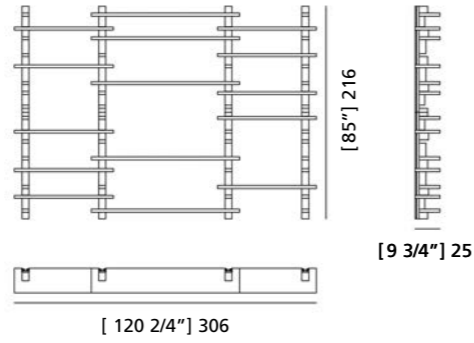

MISURE: L 306 P 25 H 216
DESCRIZIONE: la libreria Shark si compone di due elementi in legno massello, montanti e mensole. I primi, lavorati con un sapiente gioco di scanalature e fissati ad una distanza predeterminata, fanno da appoggio per le mensole, che si inseriscono nei tagli del montante in corrispondenza di un apposito scanco realizzato sulla parte posteriore. Design Giuseppe Viganò
PESO: 115 kg - m³: 0,3 - COLLI: 6

MEASURES: L 306 W 25 H 216
DESCRIPTION: the Shark library is composed of solid wooden frame elements and shelves. The frame elements, are fixed to the wall and have grooves to support the shelves. The shelves can be easily moved changing the wall composition according to your necessities. Design by Giuseppe Viganò
WEIGHT: 115 kg - m³: 0,3 - PIECES: 6

ART. FS3414569
LIBRERIA SHARK

CUSTOMIZABLE

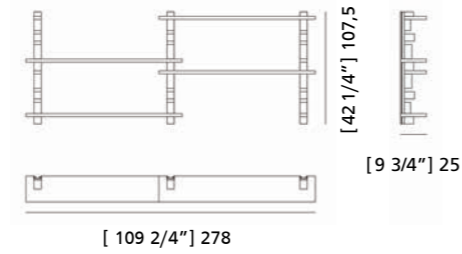

MISURE: L 278 P 25 H 107,5
DESCRIZIONE: Libreria composta da 3 montanti e 4 ripiani grandi. Design Giuseppe Viganò
PESO: 53 kg - m³: 0,2
COLLI: 2

MEASURES: L 278 W 25 H 107,5
DESCRIPTION: Bookcase made up of 3 uprights and 4 large shelves. Design by Giuseppe Viganò
WEIGHT: 53 kg - m³: 0,2
PIECES: 2

ART. FS3414570
LIBRERIA SHARK

CUSTOMIZABLE

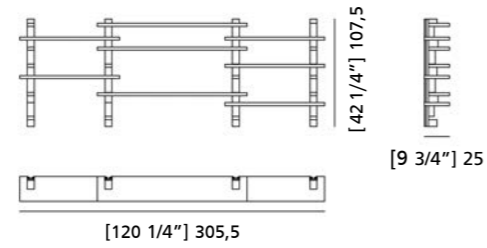

MISURE: L 305,5 P 25 H 107,5
DESCRIZIONE: Libreria composta da 4 montanti, 3 ripiani grandi e 5 ripiani piccoli. Design Giuseppe Viganò
PESO: 61 kg - m³: 0,3
COLLI: 3

MEASURES: L 305,5 W 25 H 107,5
DESCRIPTION: Bookcase made up of 4 uprights, 3 large shelves and 5 short shelves. Design by Giuseppe Viganò
WEIGHT: 61 kg - m³: 0,3
PIECES: 3

ART. 3442/F
MONTANTE LIBRERIA SHARK

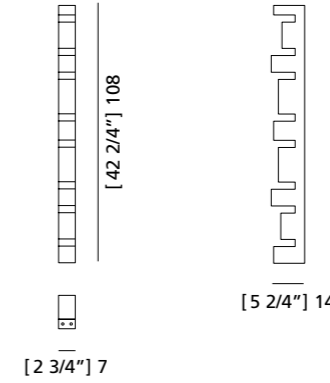

MISURE: L 7 P 14 H 108
DESCRIZIONE: montante verticale in legno massello di frassino
Design Giuseppe Viganò
PESO: 5 kg - m³: 0,01
COLLI: 1

MEASURES: L 7 W 14 H 108
DESCRIPTION: uprights made of solid Ash wood. Design by Giuseppe Viganò
WEIGHT: 5 kg - m³: 0,01
PIECES: 1

ART. 3443/F
RIPIANO LIBRERIA SHARK

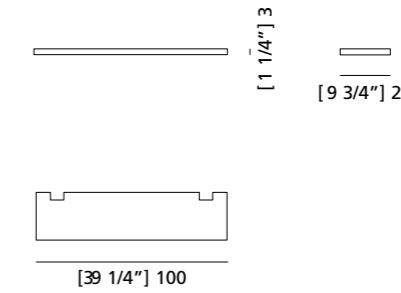

MISURE: L 100 P 25 H 3
DESCRIZIONE: ripiano in legno di frassino. Design Giuseppe Viganò
PESO: 4 kg - m³: 0,01
COLLI: 1

MEASURES: L 100 W 25 H 3
DESCRIPTION: Ash wood shelf. Design by Giuseppe Viganò
WEIGHT: 4 kg - m³: 0,01
PIECES: 1

ART. 3444/F
RIPIANO LIBRERIA SHARK

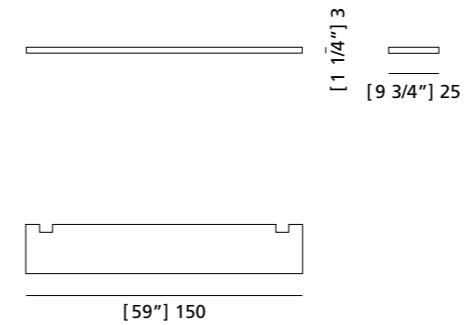

MISURE: L 150 P 25 H 3
DESCRIZIONE: ripiano in legno di frassino. Design Giuseppe Viganò
PESO: 7 kg - m³: 0,01
COLLI: 1

MEASURES: L 150 W 25 H 3
DESCRIPTION: Ash wood shelf. Design by Giuseppe Viganò
WEIGHT: 7 kg - m³: 0,01
PIECES: 1



ART. 3266
MOBILE BIBLIOTECA

CUSTOMIZABLE

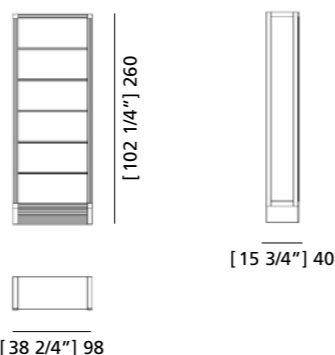

MISURE: L 98 P 40 H 260
DESCRIZIONE: libreria Biblioteca a giorno. 1 elemento con ripiani regolabili e 1 cassetto alla base. Struttura in legno di ciliegio con pregiata fresatura sui fianchi e sui cassetti. Finitura: F60.
 Design Centro Ricerche MAM
 PESO: 125 kg - m³: 0,4
 COLLI: 6

MEASURES: L 98 W 40 H 260
DESCRIPTION: Biblioteca modular bookcase, 1 open element made of cherry wood with adjustable shelves and 1 drawer. Fine milling on the sides and drawers. Finishing: F60.
 Design by Centro Ricerche MAM
 WEIGHT: 125 kg - m³: 0,4
 PIECES: 6

ART. 3267
MOBILE BIBLIOTECA

CUSTOMIZABLE

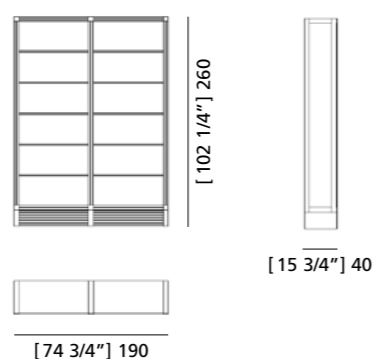

MISURE: L 190 P 40 H 260
DESCRIZIONE: libreria Biblioteca a giorno. 2 elementi con ripiani regolabili e 1 cassetto alla base. Struttura in legno di ciliegio con pregiata fresatura sui fianchi e sui cassetti. Finitura: F60.
 Design Centro Ricerche MAM
 PESO: 180 kg - m³: 1
 COLLI: 10

MEASURES: L 190 W 40 H 260
DESCRIPTION: Biblioteca modular bookcase, 2 open elements made of cherry wood with adjustable shelves and 1 drawer. Fine milling on the sides and drawers. Finishing: F60.
 Design by Centro Ricerche MAM
 WEIGHT: 180 kg - m³: 1
 PIECES: 10

ART. 3268
MOBILE BIBLIOTECA

CUSTOMIZABLE

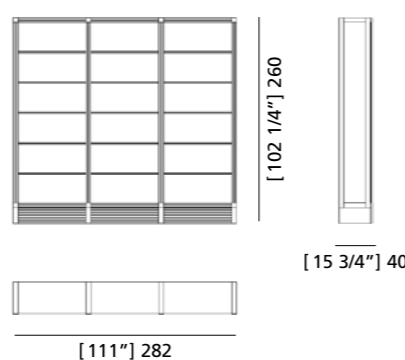

MISURE: L 282 P 40 H 260
DESCRIZIONE: libreria Biblioteca a giorno. 3 elementi con ripiani regolabili e 1 cassetto alla base. Struttura in legno di ciliegio con pregiata fresatura sui fianchi e sui cassetti. Finitura: F60.
 Design Centro Ricerche MAM
 PESO: 250 kg - m³: 1,5
 COLLI: 13

MEASURES: L 282 W 40 H 260
DESCRIPTION: Biblioteca modular bookcase, 3 open elements made of cherry wood with adjustable shelves and 1 drawer. Fine milling on the sides and drawers. Finishing: F60.
 Design by Centro Ricerche MAM
 WEIGHT: 250 kg - m³: 1,5
 PIECES: 13

ART. 3274
MOBILE BIBLIOTECA

CUSTOMIZABLE

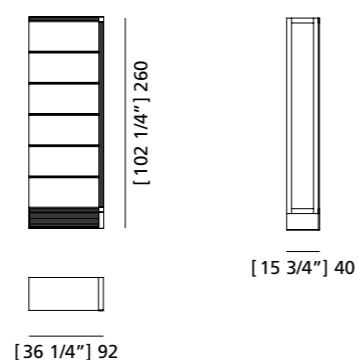

MISURE: L 92 P 40 H 260
DESCRIZIONE: libreria Biblioteca a giorno. Elemento aggiuntivo con ripiani regolabili e 1 cassetto alla base. Struttura in legno di ciliegio con pregiata fresatura sui fianchi e sui cassetti. Finitura: F60.
 Design by Centro Ricerche MAM
 PESO: 70 kg - m³: 0,4
 COLLI: 4

MEASURES: L 92 W 40 H 260
DESCRIPTION: Biblioteca modular bookcase, additional open element made of cherry wood with adjustable shelves and 1 drawer. Fine milling on the sides and drawers. Finishing: F60.
 Design by Centro Ricerche MAM
 WEIGHT: 70 kg - m³: 0,4
 PIECES: 4

MODULI
COMPONIBILI

WALL-UNITS



ART. 6205/F
LIBRERIA SWING

CUSTOMIZABLE

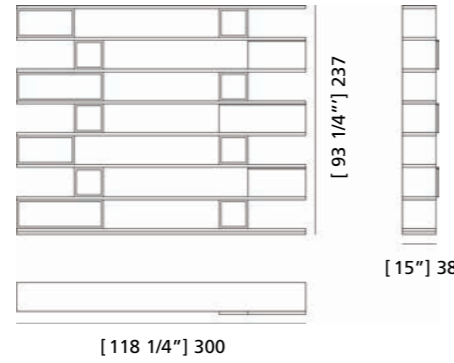
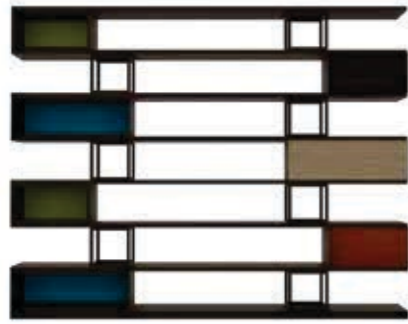

MISURE: L 300 P 38 H 237
DESCRIZIONE: Libreria scaffalatura con moduli chiusi da anta a battente, moduli a giorno e moduli in ferro. Finitura F32/F. Design Libero Rutilo
PESO: 120 kg - m³: 1,3 COLLI: 2

MEASURES: L 300 P 38 H 237
DESCRIPTION: Bookcase made of ash wood with doors and open elements. Design: Libero Rutilo
WEIGHT: 120 kg - m³: 1,3 - PIECES: 2

ART. 3630/F
MODULO SWING

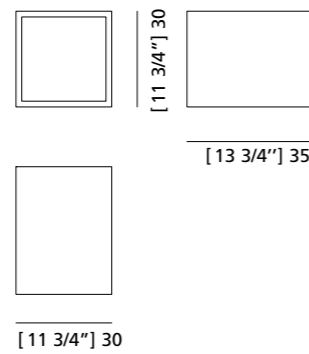

MISURE: L 30 P 35 H 30
DESCRIZIONE: modulo Swing a giorno in legno di frassino
Design Centro Ricerche - MAMM
PESO: 4 kg - m³: 0,04
COLLI: 1

MEASURES: L 30 W 35 H 30
DESCRIPTION: Swing open modular element made of ash wood
Design by Centro Ricerche - MAMM
WEIGHT: 4 kg - m³: 0,04
PIECES: 1

ART. 3631/F
MODULO SWING

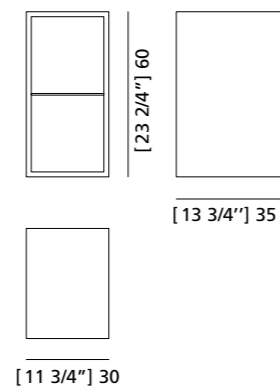

MISURE: L 30 P 35 H 60
DESCRIZIONE: modulo Swing a giorno in legno di frassino con ripiano in cristallo
Design Centro Ricerche - MAMM
PESO: 8 kg - m³: 0,08
COLLI: 2

MEASURES: L 30 W 35 H 60
DESCRIPTION: Swing open modular element made of ash wood with glass shelf
Design by Centro Ricerche - MAMM
WEIGHT: 8 kg - m³: 0,08
PIECES: 2

ART. 3632/F
MODULO SWING

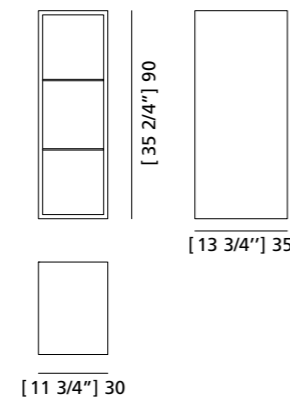

MISURE: L 30 P 35 H 90
DESCRIZIONE: modulo Swing a giorno in legno di frassino con due ripiani in cristallo
Design Centro Ricerche - MAMM
PESO: 14 kg - m³: 0,12
COLLI: 1

MEASURES: L 30 W 35 H 90
DESCRIPTION: Swing open modular element made of ash wood with 2 glass shelves
Design by Centro Ricerche - MAMM
WEIGHT: 14 kg - m³: 0,12
PIECES: 1

ART. 3633/F
MODULO SWING

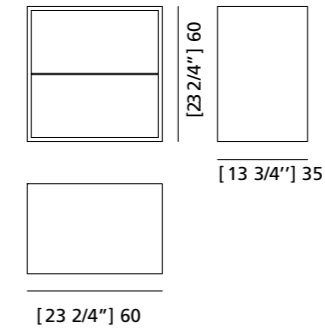

MISURE: L 60 P 35 H 60
DESCRIZIONE: modulo Swing a giorno in legno di frassino con ripiano in cristallo
Design Centro Ricerche - MAMM
PESO: 10 kg - m³: 0,17
COLLI: 2

MEASURES: L 60 W 35 H 60
DESCRIPTION: Swing open modular element made of ash wood with glass shelf
Design by Centro Ricerche - MAMM
WEIGHT: 10 kg - m³: 0,17
PIECES: 2

ART. 3634/F
MODULO SWING

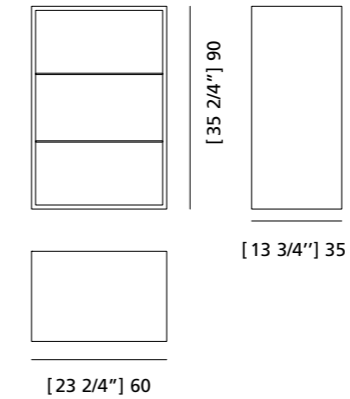

MISURE: L 60 P 35 H 90
DESCRIZIONE: modulo Swing a giorno in legno di frassino con due ripiani in cristallo
Design Centro Ricerche - MAMM
PESO: 17 kg - m³: 0,22
COLLI: 2

MEASURES: L 60 W 35 H 90
DESCRIPTION: Swing open modular element made of ash wood with 2 glass shelves
Design by Centro Ricerche - MAMM
WEIGHT: 17 kg - m³: 0,22
PIECES: 2

ART. 3644/F
MODULO SWING

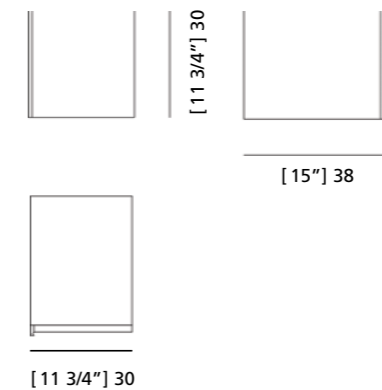

MISURE: L 30 P 38 H 30
DESCRIZIONE: Modulo Swing in legno di frassino con anta
Design Centro Ricerche - MAMM
PESO: 6 kg - m³: 0,04
COLLI: 1

MEASURES: L 30 W 38 H 30
DESCRIPTION: Swing modular element made of ash wood with door
Design by Centro Ricerche - MAMM
WEIGHT: 6 kg - m³: 0,04
PIECES: 1

ART. 3645/F
MODULO SWING

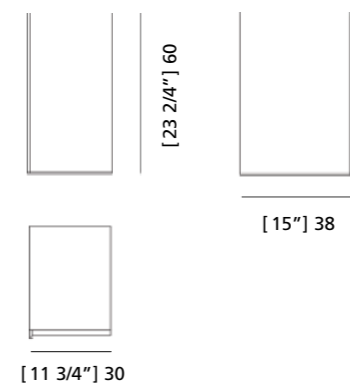

MISURE: L 30 P 38 H 60
DESCRIZIONE: Modulo Swing in legno di frassino con anta e ripiano in cristallo
Design Centro Ricerche - MAMM
PESO: 10 kg - m³: 0,08
COLLI: 1

MEASURES: L 30 W 38 H 60
DESCRIPTION: Swing modular element made of ash wood with door and glass shelf
Design by Centro Ricerche - MAMM
WEIGHT: 10 kg - m³: 0,08
PIECES: 1

ART. 3646/F
MODULO SWING

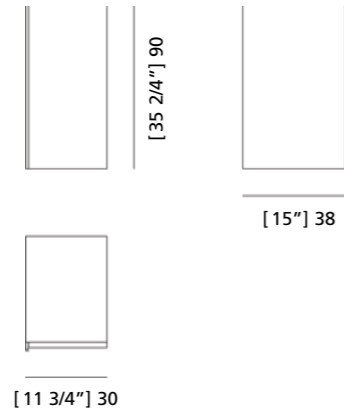

MISURE: L 30 P 38 H 90
DESCRIZIONE: Modulo Swing in legno di frassino con anta e due ripiani in cristallo
Design Centro Ricerche - MAMM
PESO: 17 kg - m³: 0,12
COLLI: 1

MEASURES: L 30 W 38 H 90
DESCRIPTION: Swing modular element made of ash wood with door and two glass shelves
Design by Centro Ricerche - MAMM
WEIGHT: 17 kg - m³: 0,12
PIECES: 1

ART. 3647/F
MODULO SWING

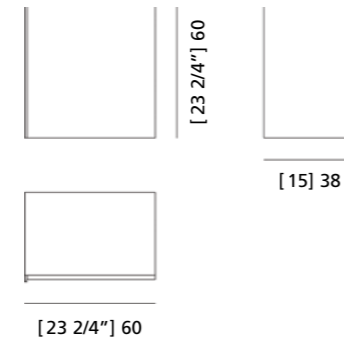

MISURE: L 60 P 38 H 60
DESCRIZIONE: Modulo Swing in legno di frassino con anta e ripiano in cristallo
Design Centro Ricerche - MAMM
PESO: 15 kg - m³: 0,17
COLLI: 1

MEASURES: L 60 W 38 H 60
DESCRIPTION: Swing modular element made of ash wood with door and glass shelf
Design by Centro Ricerche - MAMM
WEIGHT: 15 kg - m³: 0,17
PIECES: 1

ART. 3648/F
MODULO SWING

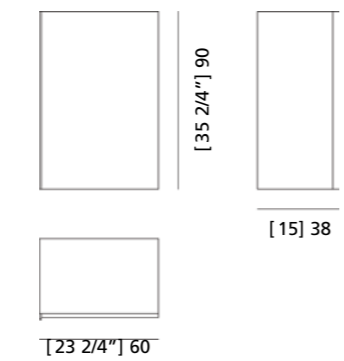

MISURE: L 60 P 38 H 90
DESCRIZIONE: Modulo Swing in legno di frassino con anta e due ripiani in cristallo
Design Centro Ricerche - MAMM
PESO: 22 kg - m³: 0,22
COLLI: 1

MEASURES: L 60 P 38 H 90
DESCRIPTION: Swing modular element made of ash wood with door and two glass shelves
Design by Centro Ricerche - MAMM
WEIGHT: 22 kg - m³: 0,22
PIECES: 1

ART. 3643/F
MODULO SWING CON CASSETTO

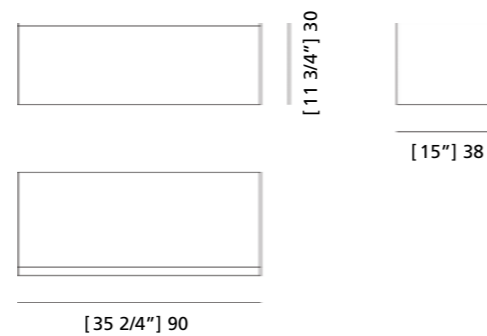

MISURE: L 90 P 38 H 30
DESCRIZIONE: Modulo Swing con cassetto in legno di frassino
Design Centro Ricerche - MAMM
PESO: 10 kg - m³: 0,3
COLLI: 1

MEASURES: L 90 W 38 H 30
DESCRIPTION: Swing modular element with drawer made of ash wood
Design by Centro Ricerche - MAMM
WEIGHT: 10 kg - m³: 0,3
PIECES: 1

ART. 3642/F
MODULO SWING CON CASSETTO

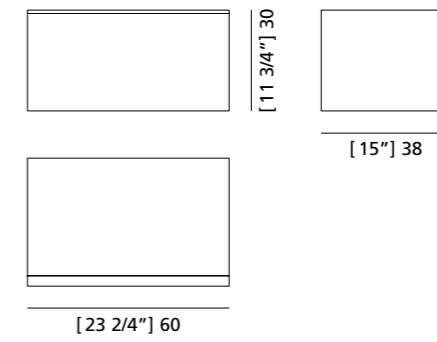

MISURE: L 60 P 38 H 30
DESCRIZIONE: Modulo Swing con cassetto in legno di frassino
Design Centro Ricerche - MAMM
PESO: 10 kg - m³: 0,3
COLLI: 1

MEASURES: L 60 P 38 H 30
DESCRIPTION: Swing modular element with drawer made of ash wood
Design by Centro Ricerche - MAMM
WEIGHT: 10 kg - m³: 0,3
PIECES: 1

ART. 3660/F
BASE SWING

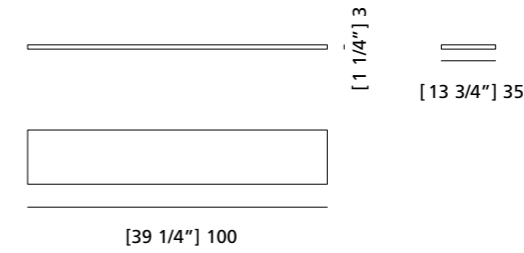

MISURE: L 100 P 35 H 3
DESCRIZIONE: Base per moduli Swing

MEASURES: L 100 P 35 H 3
DESCRIPTION: Base for modular Swing elements

ART. 3671
MODULO SWING

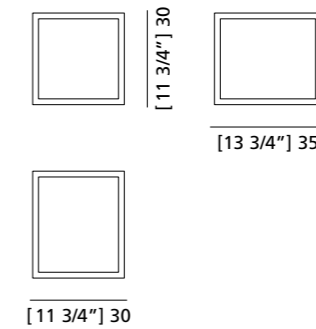
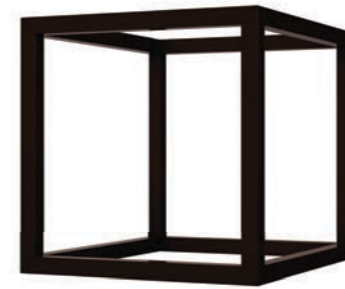

MISURE: L 30 P 35 H 30
DESCRIZIONE: Modulo a giorno in ferro.

MEASURES: L 30 W 53 H 30
DESCRIPTION: Metal open element

ART. 3689
MODULO SWING

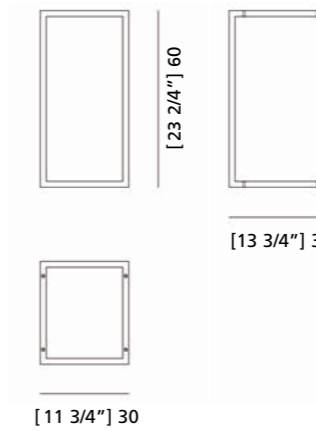
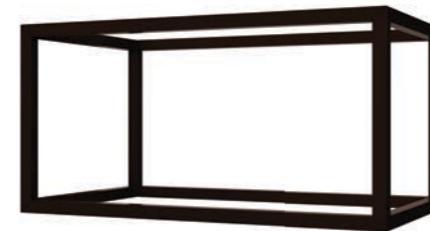

MISURE: L 30 P 35 H 60
DESCRIZIONE: Modulo a giorno in ferro.

MEASURES: L 30 W 53 H 60
DESCRIPTION: Metal open element



ART. 3667/F
MODULO SWING

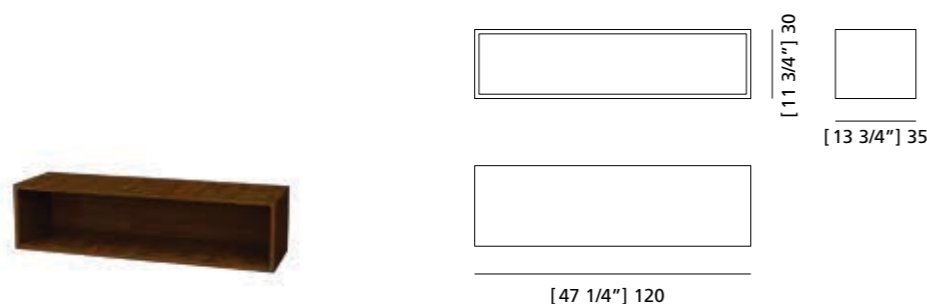

MISURE: L 120 P 35 H 30
DESCRIZIONE: Modulo a giorno in legno di frassino. Design Libero Rutilo

MEASURES: L 120 P 35 H 30
DESCRIPTION: Swing modular open element made of ash wood

ART. 3668/F
MODULO SWING

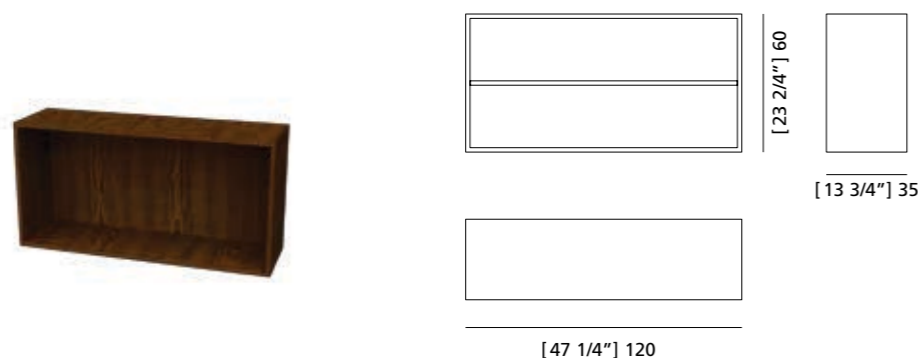

MISURE: L 120 P 35 H 60
DESCRIZIONE: Modulo a giorno in legno di frassino, un ripiano interno. Design Libero Rutilo

MEASURES: L 120 P 35 H 60
DESCRIPTION: Swing modular open element made of ash wood

ART. 3669/F
MODULO SWING

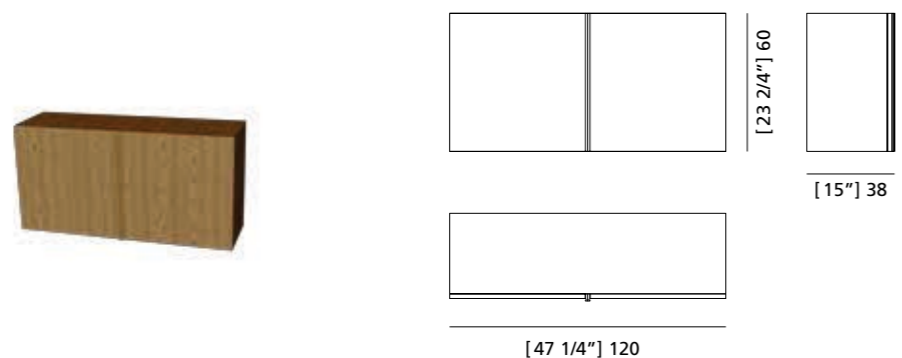

MISURE: L 120 P 38 H 60
DESCRIZIONE: Modulo in legno di frassino con due ante a battente. Design Libero Rutilo

MEASURES: L 120 P 38 H 60
DESCRIPTION: Swing modular element with two doors made of ash wood

ART. 3670/F
MODULO SWING

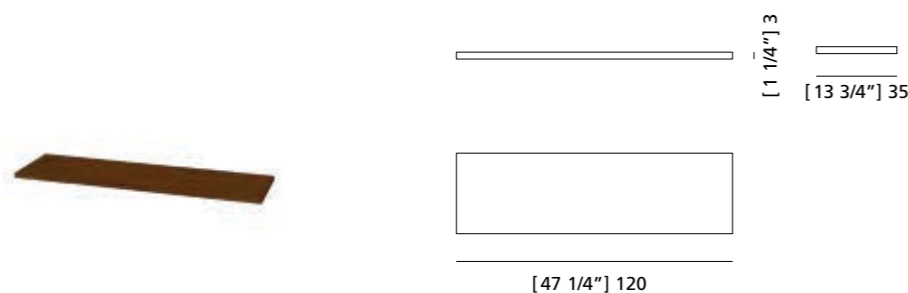

MISURE: L 120 P 35 H 3
DESCRIZIONE: Ripiano in legno di frassino. Design Libero Rutilo

MEASURES: L 120 P 35 H 3
DESCRIPTION: Ash wood shelf

ART. 3672
MODULO SWING

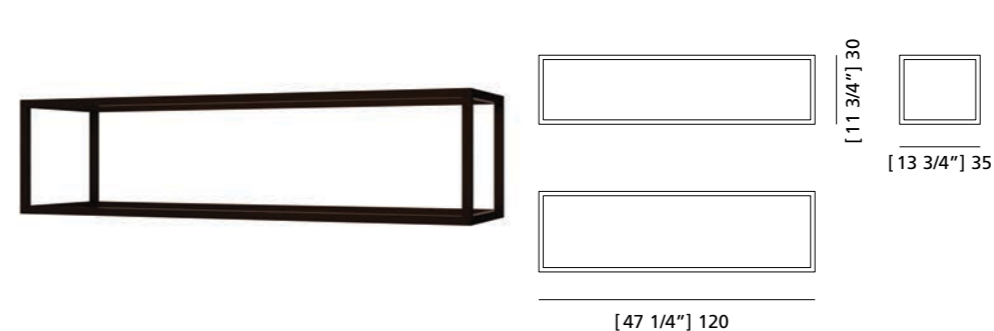

MISURE: L 120 P 35 H 30
DESCRIZIONE: Modulo a giorno in ferro. Design Libero Rutilo

MEASURES: L 120 P 35 H 30
DESCRIPTION: Metal open element

ART. 3673/F
MODULO SWING



MISURE: L 120 P 2 H 210
DESCRIZIONE: Pannello boiserie in legno di frassino. Design Libero Rutilo

MEASURES: L 120 P 2 H 210
DESCRIPTION: Boiserie panel in ash wood

ART. A0102065
LUCE LED PER MODULI

ART. A0102075
TRASFORMATORE



DESCRIZIONE: Luce led su profilo in alluminio angolare 120 LED/metro, luce a scelta Fredda/Naturale/Calda, assorbimento 9,6 Watt/metro. Complete di driver in potenza dedicato e cablaggio.

DESCRIPTION: Led light on angular aluminum profile 120 LED/meter, light options: Cold/Natural/Warm, power absorption 9,6 Watt/meter. Supplied with dedicated power driver and the concealed cable wiring.

ART. A0102045
CREMAGLIERA SX PER SWING

ART. A0102055
CREMAGLIERA CENTRALE PER SWING

ART. A0102035
CREMAGLIERA DX PER SWING

ART. A0102025
STAFFE PER MODULI SOSPESI

ART. A0102015
REGGIMENSOLA



ART. 1733/F
CREDENZA SWING

CUSTOMIZABLE

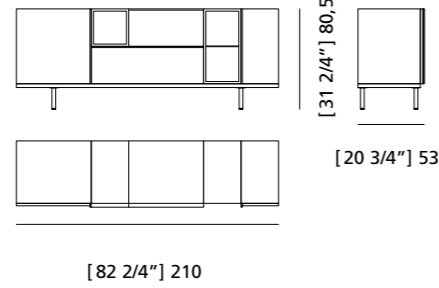

MISURE: L 210 P 53 H 80,5
DESCRIZIONE: Credenza in legno di frassino composta da 3 moduli con anta, 1 modulo con cassetto, 2 moduli a giorno. Ripiani interni in cristallo. Base con piedi in ottone regolabili.
Design Centro Ricerche MAM
PESO: 71 kg - m³: 0,80 - COLLI: 1

MEASURES: L 210 W 53 H 80,5
DESCRIPTION: Sideboard in ash composed of 3 modules with doors, 1 module with drawer 2 open modules. Internal glass shelves. Base with adjustable brass feet.
Design by Centro Ricerche MAM
WEIGHT: 71 kg - m³: 0,80 - PIECES: 1

ART. 1734/F
CREDENZA SWING

CUSTOMIZABLE

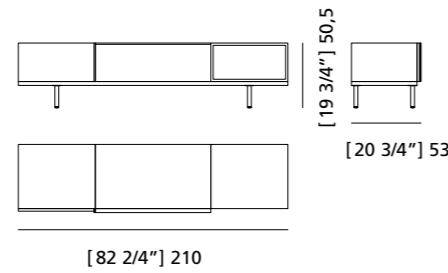

MISURE: L 210 P 53 H 50,5
DESCRIZIONE: Credenza in legno di frassino composta da 1 modulo con anta, 1 modulo con cassetto, 1 modulo a giorno. Base con piedi in ottone regolabili.
Design Centro Ricerche MAM
PESO: 45 kg - m³: 0,50 - COLLI: 1

MEASURES: L 210 W 53 H 50,5
DESCRIPTION: Sideboard in ash composed of 1 module with doors, 1 module with drawer 1 open module. Base with adjustable brass feet.
Design by Centro Ricerche MAM
WEIGHT: 45 kg - m³: 0,50 - PIECES: 1

ART. 1735/F
CREDENZA SWING

CUSTOMIZABLE

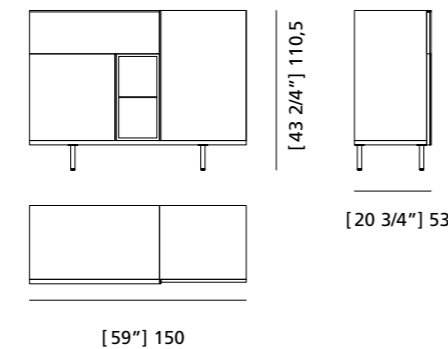

MISURE: L 150 P 53 H 110,5
DESCRIZIONE: Credenza in legno di frassino composta da 2 moduli con anta, 1 modulo con cassetto, 1 modulo a giorno. Ripiani interni in cristallo. Base con piedi in ottone regolabili.
Design Centro Ricerche MAM
PESO: 69 kg - m³: 0,80 - COLLI: 1

MEASURES: L 150 W 53 H 110,5
DESCRIPTION: Sideboard in ash composed of 2 modules with doors, 1 module with drawer, 1 open module. Internal glass shelves. Base with adjustable brass feet.
Design by Centro Ricerche MAM
WEIGHT: 69 kg - m³: 0,80 - PIECES: 1

ART. 1736/F
CREDENZA SWING

CUSTOMIZABLE

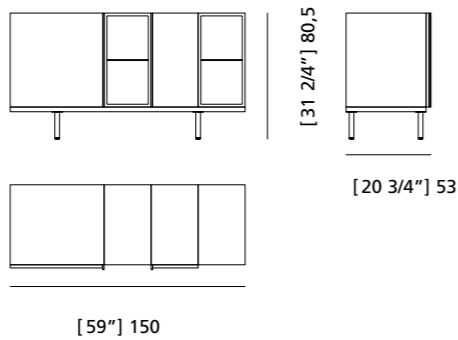

MISURE: L 150 P 53 H 80,5
DESCRIZIONE: Credenza in legno di frassino composta da 2 moduli con anta e 2 moduli a giorno. Ripiani interni in cristallo. Base con piedi in ottone regolabili.
Design Centro Ricerche MAM
PESO: 59 kg - m³: 0,60 - COLLI: 1

MEASURES: L 150 W 53 H 80,5
DESCRIPTION: Sideboard in ash composed of 2 modules with doors, 2 open modules. Internal glass shelves. Base with adjustable brass feet.
Design by Centro Ricerche MAM
WEIGHT: 59 kg - m³: 0,60 - PIECES: 1

ART. 1742/F
CREDENZA SWING

CUSTOMIZABLE

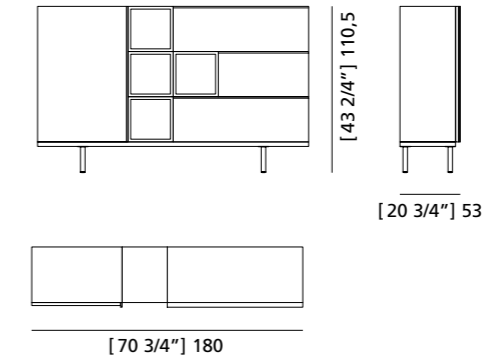

MISURE: L 180 P 53 H 110,5
DESCRIZIONE: Credenza in legno di frassino composta da moduli a giorno, moduli con anta e moduli con cassetto, ripiani interni in cristallo, base con piedi in ottone regolabili.
PESO: 80 kg - m³: 1,05 - COLLI: 1

MEASURES: L 180 P 53 H 110,5
DESCRIPTION: Sideboard in ash wood with doors, drawers and open elements internal glass shelves. Base with adjustable brass feet.
WEIGHT: 80 kg - m³: 1,05 - PIECES: 1

ART. 1743/F
CREDENZA SWING

CUSTOMIZABLE

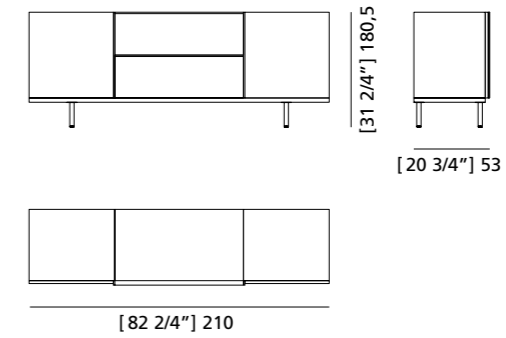

MISURE: L 210 P 53 H 80,5
DESCRIZIONE: Credenza in legno di frassino composta da moduli con anta e moduli con cassetto, ripiani interni in cristallo, base con piedi in ottone regolabili.
PESO: 70 kg - m³: 0,90 - COLLI: 1

MEASURES: L 210 P 53 H 80,5
DESCRIPTION: Sideboard in ash wood with doors and drawers. Base with adjustable brass feet.
WEIGHT: 70 kg - m³: 0,90 - PIECES: 1

ART. 1744/F
CREDENZA SWING

CUSTOMIZABLE

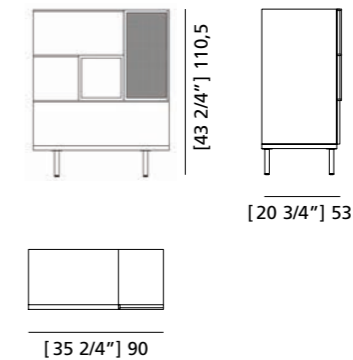

MISURE: L 90 P 53 H 110,5
DESCRIZIONE: Credenza in legno di frassino composta da moduli con anta, moduli a giorno e moduli con cassetto, ripiani interni in cristallo, base con piedi in ottone regolabili.
PESO: 45 kg - m³: 0,50 - COLLI: 1

MEASURES: L 90 P 53 H 110,5
DESCRIPTION: Sideboard in ash wood with doors, drawers and open element. Base with adjustable brass feet.
WEIGHT: 45 kg - m³: 0,50 - PIECES: 1

ART. 5801/F
CONSOLE SWING

CUSTOMIZABLE

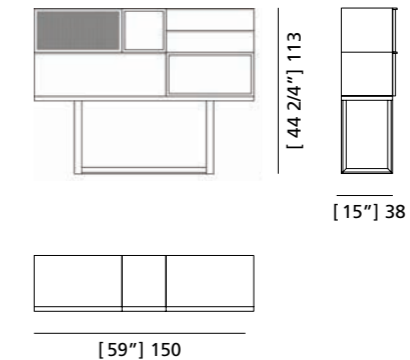

MISURE: L 150 P 38 H 113
DESCRIZIONE: Consolle in legno di frassino composta da moduli con cassetto e moduli a giorno, base con struttura in legno.
PESO: 40 kg - m³: 0,65 - COLLI: 1

MEASURES: L 150 P 38 H 113
DESCRIPTION: Console in ash wood with doors, drawers and open element.
WEIGHT: 40 kg - m³: 0,65 - PIECES: 1

ART. 3653/F
MODULO SWING

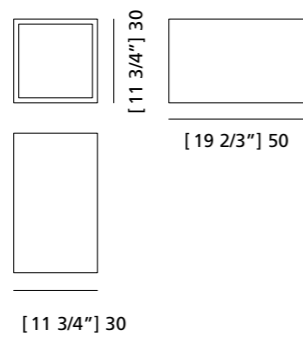

MISURE: L 30 P 50 H 30
DESCRIZIONE: Modulo Swing a giorno in legno di Frassino.

MEASURES: L 30 P 50 H 30
DESCRIPTION: Swing Open modular element made of ash wood.

ART. 3654/F
MODULO SWING

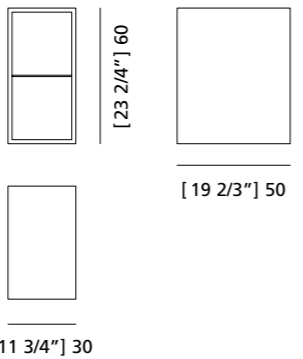

MISURE: L 30 P 50 H 60
DESCRIZIONE: Modulo Swing a giorno in legno di Frassino con ripiano.

MEASURES: L 30 P 50 H 60
DESCRIPTION: Swing Open modular element made of ash wood with one shelf.

ART. 3655/F
MODULO SWING

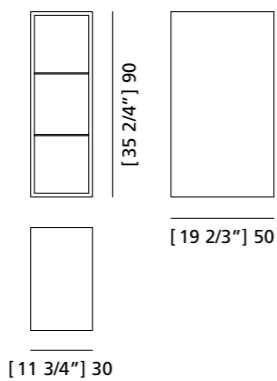

MISURE: L 30 W 50 H 90
DESCRIZIONE: Modulo Swing a giorno in legno di Frassino con due ripiani.

MEASURES: L 30 W 50 H 90
DESCRIPTION: Swing Open modular element made of ash wood with two shelves.

ART. 3656/F
MODULO SWING

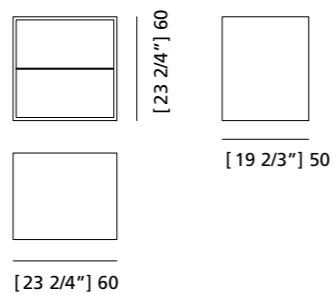

MISURE: L 60 W 50 H 60
DESCRIZIONE: Modulo Swing a giorno in legno di Frassino con ripiano.

MEASURES: L 60 W 50 H 60
DESCRIPTION: Swing Open modular element made of ash wood with one shelf.

ART. 3657/F
MODULO SWING

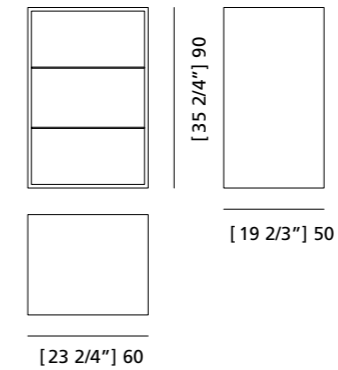

MISURE: L 60 P 50 H 90
DESCRIZIONE: Modulo Swing a giorno in legno di Frassino con due ripiani.

MEASURES: L 60 P 50 H 90
DESCRIPTION: Swing Open modular element made of ash wood with two shelves.

ART. 3658/F
MODULO SWING CON CASSETTO

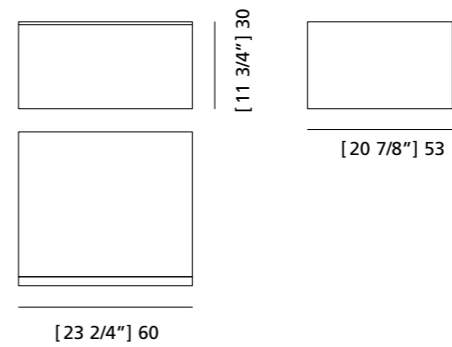

MISURE: L 60 P 53 H 30
DESCRIZIONE: Modulo Swing con cassetto in legno di frassino

MEASURES: L 60 P 53 H 30
DESCRIPTION: Swing modular element with drawer made of ash wood

ART. 3662/F
MODULO SWING

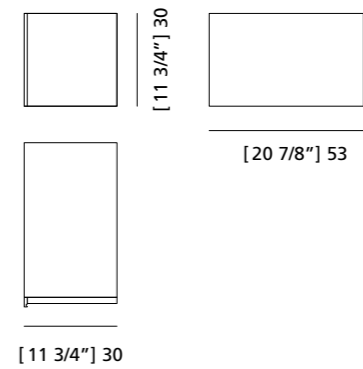

MISURE: L 30 P 53 H 30
DESCRIZIONE: Modulo Swing con anta in legno di Frassino.

MEASURES: L 30 P 53 H 30
DESCRIPTION: Swing modular element with door made of ash wood.

ART. 3663/F
MODULO SWING

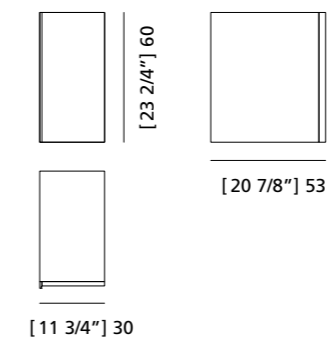

MISURE: L 30 W 53 H 60
DESCRIZIONE: Modulo Swing con anta in legno di Frassino e un ripiano.

MEASURES: L 30 W 53 H 60
DESCRIPTION: Swing modular element with door made of ash wood and one shelf.

ART. 3659/F
MODULO SWING CON CASSETTO

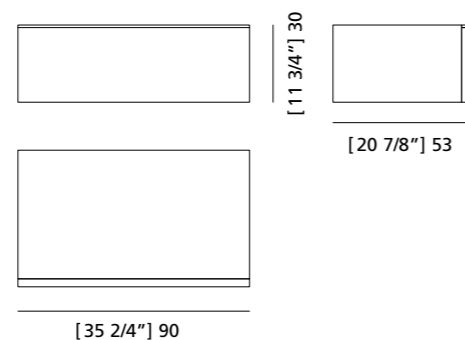

MISURE: L 90 P 53 H 30
DESCRIZIONE: Modulo Swing con cassetto in legno di frassino
Design Centro Ricerche MAAM
PESO: 10 kg. - m³: 0,3
COLLI: 1

MEASURES: L 90 P 53 H 30
DESCRIPTION: Swing modular element with drawer made of ash wood
Design by Centro Ricerche MAAM
WEIGHT: 10 kg. - m³: 0,3
PIECES: 1

ART. 3664/F
MODULO SWING

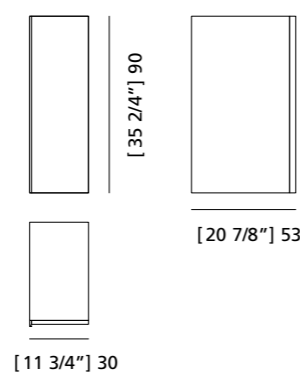

MISURE: L 30 W 53 H 90
DESCRIZIONE: Modulo Swing con anta in legno di Frassino e due ripiani.

MEASURES: L 30 W 53 H 90
DESCRIPTION: Swing modular element with door made of ash wood and two shelves.

ART. 3665/F
MODULO SWING

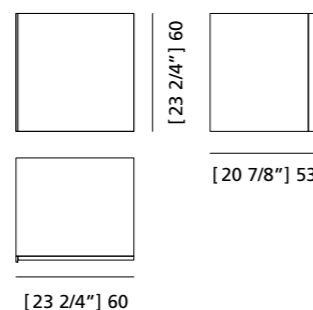

MISURE: L 60 W 53 H 60
DESCRIZIONE: Modulo Swing con anta in legno di Frassino e un ripiano.

MEASURES: L 60 W 53 H 60
DESCRIPTION: Swing modular element with door made of ash wood and one shelf.

ART. 3666/F
MODULO SWING

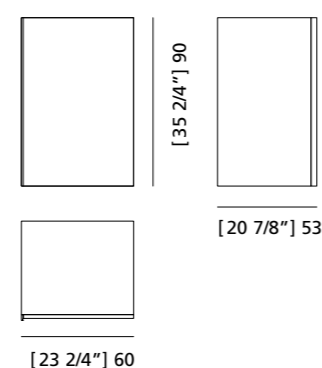

MISURE: L 60 W 53 H 90
DESCRIZIONE: Modulo Swing con anta in legno di Frassino e due ripiani.

MEASURES: L 60 W 53 H 90
DESCRIPTION: Swing modular element with door made of ash wood and two shelves.

PIEDE IN ACCIAIO

ART. A0101425



PIEDE IN ACCIAIO

ART. A0101415



PIEDE IN OTTONE

ART. A0101615



ART. 3661/F
BASE SWING

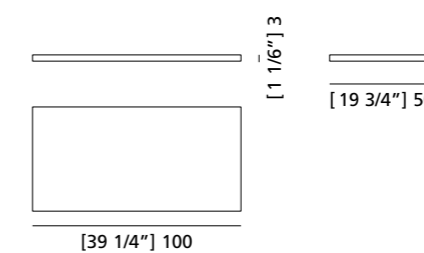

MISURE: L 100 P 50 H 3
DESCRIZIONE: Base per moduli Swing

MEASURES: L 100 P 50 H 3
DESCRIPTION: Base for modular Swing elements

ART. 3686/F
ANTA CON PAGLIA DI VIENNA

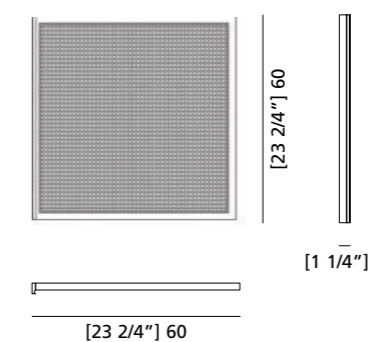

MISURE: L 60 P 3 H 60
DESCRIZIONE: Anta in legno per moduli Swing con rivestimento in paglia di Vienna.

MEASURES: L 60 P 3 H 60
DESCRIPTION: Wooden door for Swing modular elements with Vienna straw upholstery.

ART. 3687/F
ANTA IN VETRO

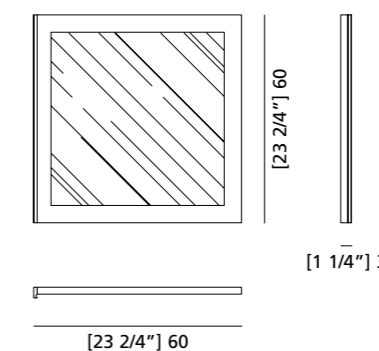
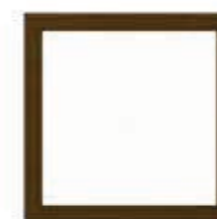

MISURE: L 60 P 3 H 60
DESCRIZIONE: Anta in vetro per moduli Swing.

MEASURES: L 60 P 3 H 60
DESCRIPTION: Glass door for Swing modular.



ART. FS3410174
COMPOSIZIONE LIBRERIA SCALA

CUSTOMIZABLE

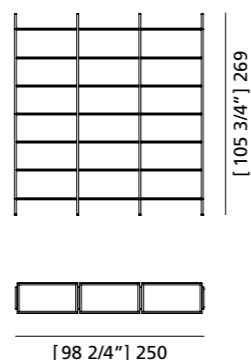
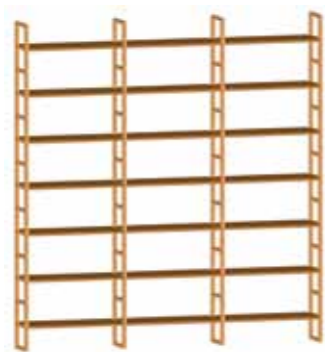

MISURE: L 250 P 40 H 269
DESCRIZIONE: proposta di libreria Scala, componibile a spalla con 4 montanti verticali in legno massello di ciliegio, con piedino regolabile in altezza, e ripiani regolabili. Finitura: F30. Design Centro Ricerche MAMM
PESO: 90 kg - m³: 0,4 - COLLI: 7

MEASURES: L 250 W 40 H 269
DESCRIPTION: proposal for modular Scala bookcase with 4 uprights made of solid cherry wood, with adjustable foot in height, and adjustable shelves. Finishing: F30. Design by Centro Ricerche MAMM
WEIGHT: 90 kg - m³: 0,4 - PIECES: 7

ART. FS3410175
COMPOSIZIONE LIBRERIA SCALA

CUSTOMIZABLE

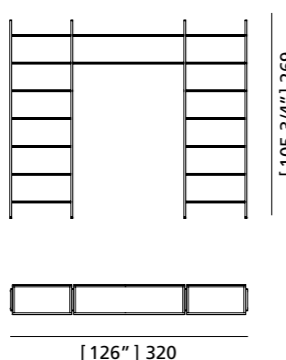

MISURE: L 320 P 40 H 269
DESCRIZIONE: proposta di libreria Scala, componibile a spalla con 4 montanti verticali in legno massello di ciliegio, con piedino regolabile in altezza, e ripiani regolabili di due lunghezze. Finitura: F30. Design Centro Ricerche MAMM
PESO: 80 kg - m³: 0,4 - COLLI: 6

MEASURES: L 320 W 40 H 269
DESCRIPTION: proposal for modular Scala bookcase, 4 uprights made of solid cherry wood with adjustable foot in height, and adjustable shelves of two lengths. Finishing: F30. Design by Centro Ricerche MAMM
WEIGHT: 80 kg - m³: 0,4 - PIECES: 6

ART. FS3410176
COMPOSIZIONE LIBRERIA SCALA

CUSTOMIZABLE

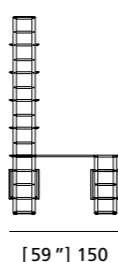
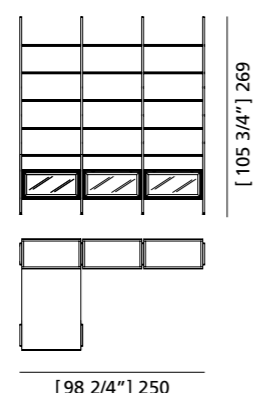

MISURE: L 250 P 150 H 269
DESCRIZIONE: proposta di libreria Scala, componibile a spalla con 4 montanti verticali in legno massello di ciliegio, ripiani regolabili e 3 elementi contenitore bifacciale con anta battente a vetro e scrittoio. Finitura: F30. Design Centro Ricerche MAMM
PESO: 175 kg - m³: 1,2 - COLLI: 10

MEASURES: L 250 W 150 H 269
DESCRIPTION: Proposal for modular Scala bookcase, with 4 uprights made of solid cherry wood, 3 adjustable shelves and storage units with double sided hinged glass doors and desk. Finishing: F30. Design by Centro Ricerche MAMM
WEIGHT: 175 kg - m³: 1,2 - PIECES: 10

ART. 3413
COMPOSIZIONE LIBRERIA SCALA

CUSTOMIZABLE

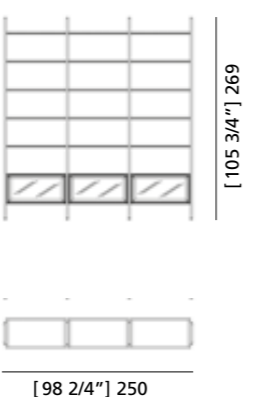

MISURE: L 250 P 40 H 269
DESCRIZIONE: Proposta di libreria Scala, componibile a spalla con 4 montanti verticali in legno massello di ciliegio con piedino regolabile in altezza, ripiani regolabili e 3 contenitori con anta battente a vetro. Finitura: F30. Design Centro Ricerche MAMM
PESO: 170 kg - m³: 1,1 - COLLI: 8

MEASURES: L 250 W 40 H 269
DESCRIPTION: proposal for modular Scala Bookcase, with 4 uprights made of solid cherry wood with adjustable foot in height, adjustable shelves and 3 storage units with glass doors. Finishing: F30. Design by Centro Ricerche MAMM
WEIGHT: 170 kg - m³: 1,1 - PIECES: 8

ART. 3410
ELEMENTO FIANCO O TRAMEZZA SCALA

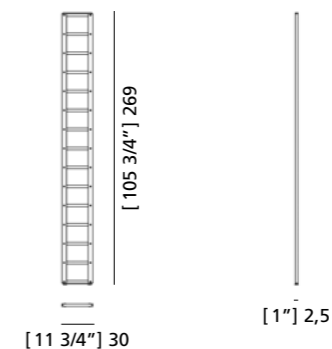

MISURE: L 2,5 P 30 H 269
DESCRIZIONE: elemento fianco, o spalla interna, in legno massello di ciliegio per composizione Scala. Piedini regolabili per fissaggio tra pavimento e soffitto. Finitura: F30
PESO: 5 kg - m³: 0,02
COLLI: 1

MEASURES: L 2,5 W 30 H 269
DESCRIPTION: side element, made of solid cherry wood for modular Scala bookcase. Adjustable legs for fixing between floor and ceiling. Finishing: F30.
WEIGHT: 5 kg - m³: 0,02
PIECES: 1

ART. 3408
ELEMENTO SCRITTOIO CON VETRINETTA SCALA

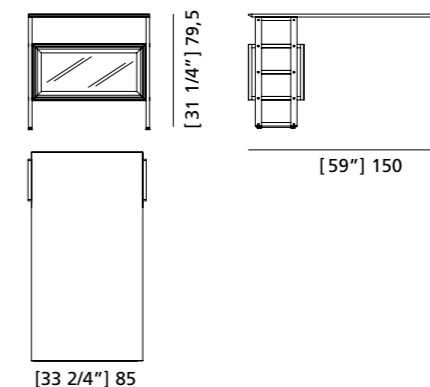

MISURE: L 85 P 150 H 79,5
DESCRIZIONE: elemento scrittoio con contenitore e anta a vetro in legno di ciliegio per composizione Scala. Finitura: F30. Design Centro Ricerche MAMM
PESO: 40 kg - m³: 0,3
COLLI: 2

MEASURES: L 85 W 150 H 79,5
DESCRIPTION: desk element with container art. 3403 and glass door art. 3405 made of cherry wood for Scala bookcase compositions. Finishing: F30. Design Centro Ricerche MAMM
WEIGHT: 40 kg - m³: 0,3
PIECES: 2

ART. 3411
ELEMENTO RIPIANO SCALA

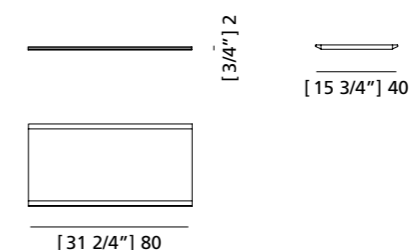

MISURE: L 80 P 40 H 2
DESCRIZIONE: ripiano in legno di ciliegio per composizione Scala. Finitura: F30
PESO: 3 kg - m³: 0,01
COLLI: 1

MEASURES: L 80 W 40 H 2
DESCRIPTION: cherry wood shelf for Scala bookcase composition. Finishing: F30
WEIGHT: 3 kg - m³: 0,01
PIECES: 1

ART. 3416
ELEMENTO RIPIANO SCALA

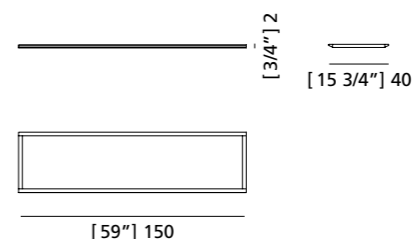

MISURE: L 150 P 40 H 2
DESCRIZIONE: ripiano in legno di ciliegio per composizione Scala. Finitura: F30
PESO: 6 kg - m³: 0,01
COLLI: 1

MEASURES: L 150 W 40 H 2
DESCRIPTION: cherry wood shelf for Scala bookcase composition. Finishing: F30
WEIGHT: 6 kg - m³: 0,01
PIECES: 1

ART. 3403
CONTENITORE A GIORNO SCALA

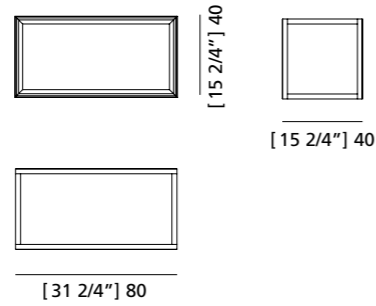

MISURE: L 80 P 40 H 40
DESCRIZIONE: elemento contenitore bifacciale in legno di ciliegio per composizione Scala. Applicabili ante a battente o ribalta. Finitura: F30
Design Centro Ricerche MAM
PESO: 15 kg - m³: 0,18
COLLI: 1
MEASURES: L 80 W 40 H 40
DESCRIPTION: double sided container element made of cherry wood for Scala bookcase compositions. Suitable for hinged or flap doors. Finishing: F30
Design by Centro Ricerche MAM
WEIGHT: 15 kg - m³: 0,18
PIECES: 1

ART. 3404
CONTENITORE A GIORNO SCALA

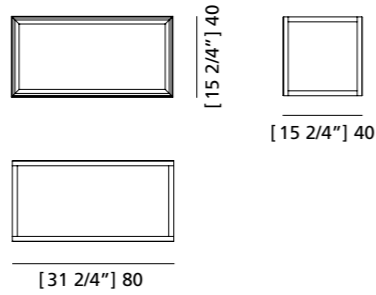

MISURE: L 80 P 40 H 40
DESCRIZIONE: elemento contenitore in legno di ciliegio per composizione Scala. Applicabili ante a battente o ribalta. Finitura: F30.
Design Centro Ricerche MAM
PESO: 22 kg - m³: 0,18
COLLI: 1
MEASURES: L 80 W 40 H 40
DESCRIPTION: container element made of cherry wood for Scala bookcase compositions. Suitable for hinged or flap doors. Finishing: F30
Design by Centro Ricerche MAM
WEIGHT: 22 kg - m³: 0,18
PIECES: 1

ART. 3405
ANTA A VETRO SCALA

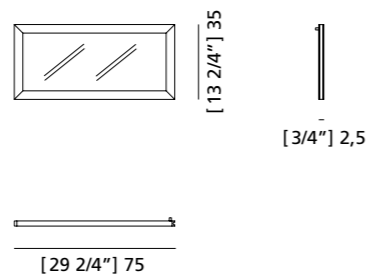

MISURE: L 75 P 2,5 H 35
DESCRIZIONE: ante per composizione Scala con struttura in legno massello di ciliegio e vetro temperato. Finitura: F30
Design Centro Ricerche MAM
PESO: 3,5 kg - m³: 0,01
COLLI: 1
MEASURES: L 75 W 2,5 H 35
DESCRIPTION: door for Scala Zero modular wall-unit. Finishing: F30
Design by Centro Ricerche MAM
WEIGHT: 3,5 kg - m³: 0,01
PIECES: 1

ART. 3406
ANTA A LISTELLI SCALA

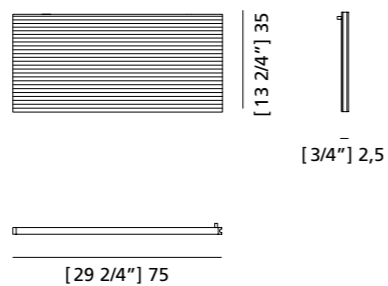

MISURE: L 75 P 2,5 H 35
DESCRIZIONE: ante per composizione Scala in legno di ciliegio con fresatura a listelli. Finitura: F30
Design Centro Ricerche MAM
PESO: 5 kg - m³: 0,01
COLLI: 1
MEASURES: L 75 W 2,5 H 35
DESCRIPTION: door for Scala bookcase composition made of cherry wood with fine strips shaped milling. Finishing: F30
Design by Centro Ricerche MAM
WEIGHT: 5 kg - m³: 0,01
PIECES: 1

ART. 3407
ANTA A MATTONCINI

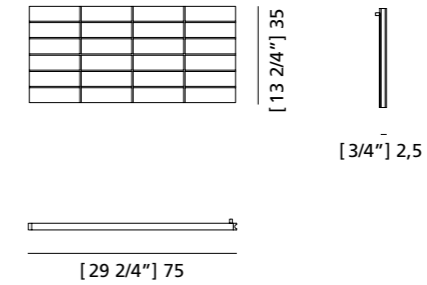
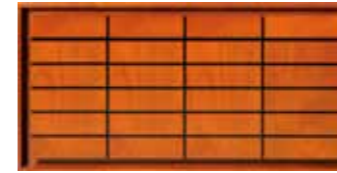

MISURE: L 75 P 2,5 H 35
DESCRIZIONE: ante per composizione Scala in legno di ciliegio con pregiato intarsio in ebano tinto a forma di mattoncini. Finitura: F60
Design Centro Ricerche MAM
PESO: 5 kg - m³: 0,01
COLLI: 1
MEASURES: L 75 W 2,5 H 35
DESCRIPTION: door for Scala bookcase composition made of cherry wood with "brick" shaped ebony inlay Finishing: F60
Design by Centro Ricerche MAM
WEIGHT: 5 kg - m³: 0,01
PIECES: 1

ART. 3418
ANTA COLORATA

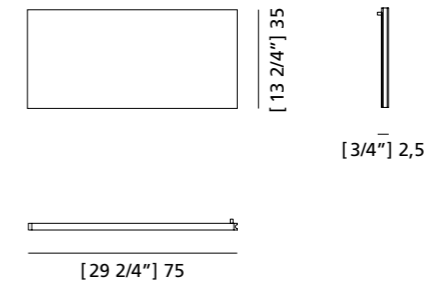

MISURE: L 75 P 2,5 H 35
DESCRIZIONE: ante per composizione Scala in legno di ciliegio colorato. Design Centro Ricerche MAM
PESO: 5 kg - m³: 0,01
COLLI: 1
MEASURES: L 75 W 2,5 H 35
DESCRIPTION: door for Scala bookcase composition made of colored cherry wood.
Design by Centro Ricerche MAM
WEIGHT: 5 kg - m³: 0,01
PIECES: 1

ART. 3419
ANTA CODE

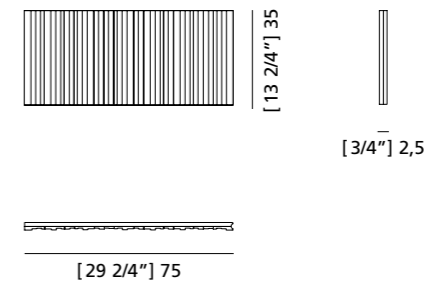

MISURE: L 75 P 2,5 H 35
DESCRIZIONE: Ante per composizione Scala con fresatura a listelli su legno massello di noce, acero e toulipier. Finitura F32
Design Centro Ricerche MAM
PESO: 6 kg - m³: 0,01
COLLI: 1
MEASURES: L 75 W 2,5 H 35
DESCRIPTION: Door for Scala Bookcase composition with strips made of solid walnut, maple and tulipwood. Finishing: F32
Design by Centro Ricerche MAM
WEIGHT: 6 kg - m³: 0,01
PIECES: 1





ART. 3493
MODULO ZERO STRUTTURA

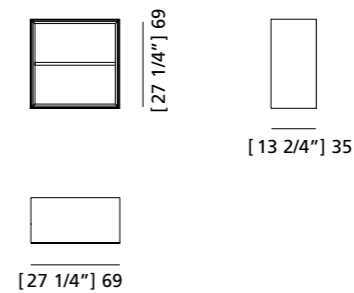

MISURE: L 69 P 35 H 69
DESCRIZIONE: elemento modulare per composizione Zero in legno di ciliegio, 1 vano con ripiano regolabile. Finitura F32 Design Centro Ricerche MAMM
PESO: 27 kg - m³: 0,23
COLLI: 1

MEASURES: L 69 W 35 H 69
DESCRIPTION: modular element for Zero composition made of cherry wood, 1 compartment with adjustable shelf. Finishing: F32 Design by Centro Ricerche MAMM
WEIGHT: 27 kg - m³: 0,23
PIECES: 1

ART. 3475
MODULO ZERO STRUTTURA

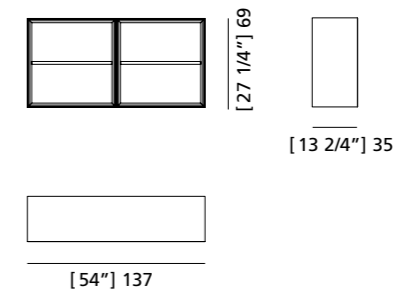

MISURE: L 137 P 35 H 69
DESCRIZIONE: elemento modulare per composizione Zero in legno di ciliegio, 2 vani con ripiano regolabile. Finitura F32 Design Centro Ricerche MAMM
PESO: 60 kg - m³: 0,37
COLLI: 1

MEASURES: L 137 W 35 H 69
DESCRIPTION: modular element for Zero composition made of cherry wood, 2 compartments with adjustable shelf. Finishing: F32 Design by Centro Ricerche MAMM
WEIGHT: 60 kg - m³: 0,37
PIECES: 1

ART. FS3714238
COMPOSIZIONE MODULO ZERO

CUSTOMIZABLE

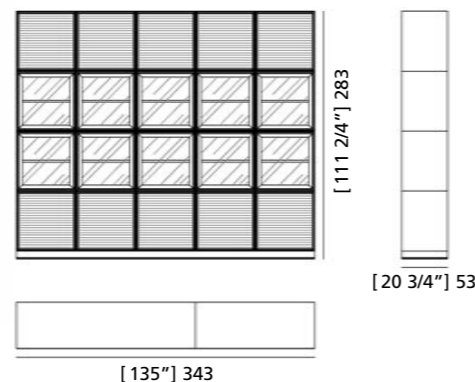

MISURE: L 343 P 53 H 283
DESCRIZIONE: Proposta di composizione Zero, base e sopralzi con ante a listelli, moduli centrali con ante a vetro, ripiani interni regolabili. Finiture: struttura F80, ante, cassetti, ripiani F34. Design Centro Ricerche MAMM
PESO: 250 kg - m³: 6 - COLLI: 9

MEASURES: L 343 P 53 H 283
DESCRIPTION: proposal for Zero composition consists wooden and glass door. Adjustable internal shelves. Finishing: F32 external, internal FL80. Design by Centro Ricerche MAMM
WEIGHT: 250 kg - m³: 6 - PIECES: 9

ART. 3478
MODULO ZERO STRUTTURA

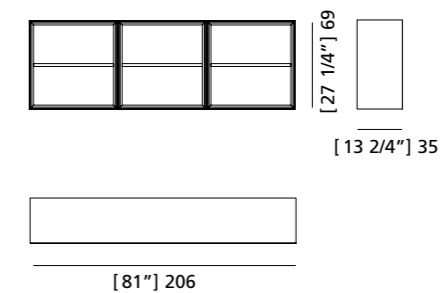

MISURE: L 206 W 35 H 69
DESCRIZIONE: elemento modulare per composizione Zero in legno di ciliegio, 3 vani con ripiano regolabile. Finitura F32 Design Centro Ricerche MAMM
PESO: 70 kg - m³: 0,55
COLLI: 1

MEASURES: L 206 P 35 H 69
DESCRIPTION: modular element for Zero composition made of cherry wood, 3 compartments with adjustable shelf. Finishing: F32 Design by Centro Ricerche MAMM
WEIGHT: 70 kg - m³: 0,55
PIECES: 1

ART. FS3410170
COMPOSIZIONE MODULO ZERO

CUSTOMIZABLE

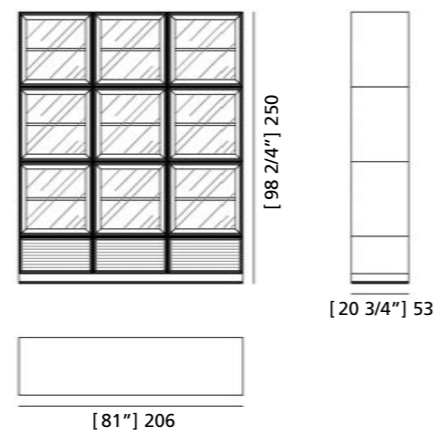

MISURE: L 206 P 53 H 250
DESCRIZIONE: proposta di composizione Zero a terra in legno di ciliegio con 1 base a 3 cassetti con frontale a listelli e 3 alzate con ripiani regolabili e ante battenti a vetro. Finiture: F80 struttura, F34 ante, cassetti, ripiani. Design Centro Ricerche MAMM
PESO: 310 kg - m³: 2,35 - COLLI: 4

MEASURES: L 206 W 53 H 250
DESCRIPTION: proposal for Zero composition consists of 1 cherry wood base element with 3 drawers, 3 cabinet elements with glass hinged doors. Finishing: external F80, F34 doors, drawers, shelves. Design by Centro Ricerche MAMM
WEIGHT: 310 kg - m³: 2,35 - PIECES: 4

ART. 3482
MODULO ZERO STRUTTURA

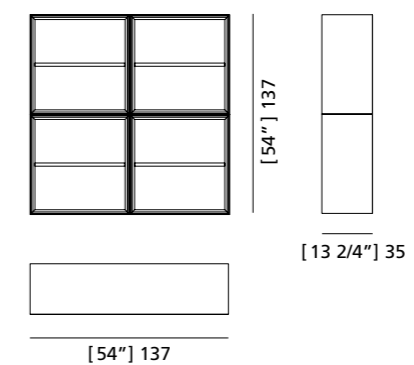

MISURE: L 137 P 35 H 137
DESCRIZIONE: elemento modulare per composizione Zero in legno di ciliegio, 4 vani con ripiano regolabile. Finitura F32 Design Centro Ricerche MAMM
PESO: 90 kg - m³: 0,72
COLLI: 1

MEASURES: L 137 W 35 H 137
DESCRIPTION: modular element for Zero composition made of cherry wood, 4 compartments with adjustable shelf. Finishing: F32 Design by Centro Ricerche MAMM
WEIGHT: 90 kg - m³: 0,72
PIECES: 1

ART. 3494
MODULO ZERO STRUTTURA

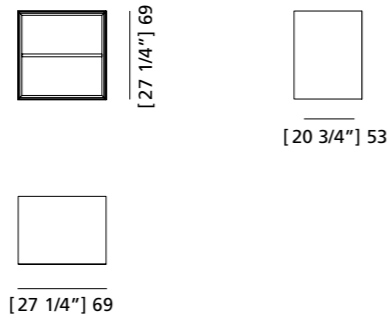

MISURE: L 69 P 53 H 69
DESCRIZIONE: elemento modulare per composizione Zero in legno di ciliegio, 1 vano con ripiano regolabile. Finitura F32 Design Centro Ricerche .
PESO: 32 kg - m³: 0,28
COLLI: 1

MEASURES: L 69 W 53 H 69
DESCRIPTION: modular element for Zero composition made of cherry wood, 1 compartment with adjustable shelf. Finishing: F32 Design by Centro Ricerche .
WEIGHT: 32 kg - m³: 0,28
PIECES: 1

ART. 3471
MODULO ZERO STRUTTURA

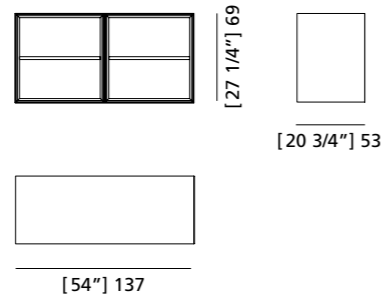

MISURE: L 137 P 53 H 69
DESCRIZIONE: elemento modulare per composizione Zero in legno di ciliegio, 2 vani con ripiano regolabile. Finitura F32 Design Centro Ricerche .
PESO: 59 kg - m³: 0,65
COLLI: 1

MEASURES: L 137 W 53 H 69
DESCRIPTION: modular element for Zero composition made of cherry wood, 2 compartments with adjustable shelf. Finishing: F32 Design by Centro Ricerche .
WEIGHT: 59 kg - m³: 0,65
PIECES: 1

ART. 3470
MODULO ZERO STRUTTURA

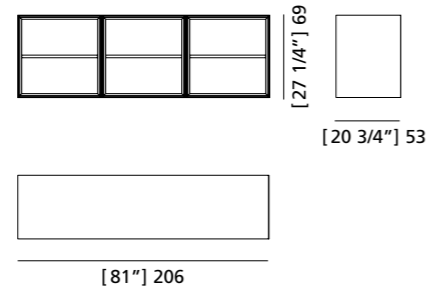

MISURE: L 206 P 53 H 69
DESCRIZIONE: elemento modulare per composizione Zero in legno di ciliegio, 3 vani con ripiano regolabile. Finitura F32 Design Centro Ricerche .
PESO: 85 kg - m³: 0,95
COLLI: 1

MEASURES: L 206 W 53 H 69
DESCRIPTION: modular element for Zero composition made of cherry wood, 3 compartments with adjustable shelf. Finishing: F32 Design by Centro Ricerche .
WEIGHT: 85 kg - m³: 0,95
PIECES: 1

ART. 3472
MODULO ZERO STRUTTURA

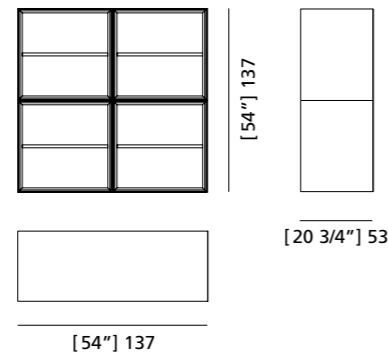

MISURE: L 137 P 53 H 137
DESCRIZIONE: elemento modulare per composizione Zero in legno di ciliegio, 4 vani con ripiano regolabile. Finitura F32 Design Centro Ricerche .
PESO: 100 kg - m³: 1,1
COLLI: 1

MEASURES: L 137 W 53 H 137
DESCRIPTION: modular element for Zero composition made of cherry wood, 4 compartments with adjustable shelf. Finishing: F32 Design by Centro Ricerche .
WEIGHT: 100 kg - m³: 1,1
PIECES: 1

ART. 3454
MODULO ZERO ANTA MATTONCINI

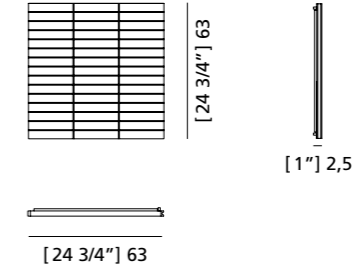
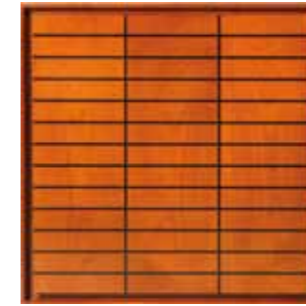

MISURE: L 63 W 2,5 H 63
DESCRIZIONE: Anta per composizioni e credenze Zero in legno di ciliegio con pregiato intarsio in ebano tinto a forma di mattoni. Finitura: F60 Design Centro Ricerche .
PESO: 6,5 kg - m³: 0,01
COLLI: 1

MEASURES: L 63 P 2,5 H 63
DESCRIPTION: Door for Zero composition and sideboards made of cherry wood with "bricks" shape inlay in ebony Finishing: F60 Design by Centro Ricerche .
WEIGHT: 6,5 kg - m³: 0,01
PIECES: 1

ART. 3456
MODULO ZERO ANTA OBLÒ

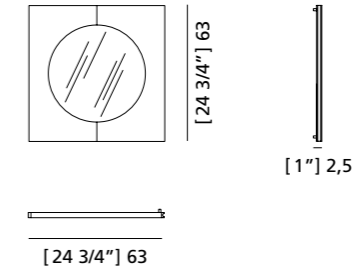

MISURE: L 63 P 2,5 H 63
DESCRIZIONE: anta per composizioni e credenze Zero con pregiata impiallacciatura di noce e acero e oblò in vetro temperato. Finitura F32 Design Centro Ricerche .
PESO: 5,5 kg - m³: 0,01
COLLI: 1

MEASURES: L 63 W 2,5 H 63
DESCRIPTION: Door for Zero composition and sideboards with "porthole" shape, veneered with maple and walnut wood. Finishing: F32 Design by Centro Ricerche .
WEIGHT: 5,5 kg - m³: 0,01
PIECES: 1

ART. 3457
MODULO ZERO ANTA VETRO

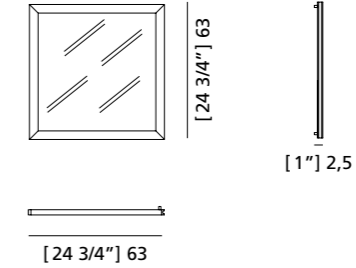

MISURE: L 63 P 2,5 H 63
DESCRIZIONE: anta per composizioni e credenze Zero con cornice in legno massello di ciliegio e vetro temperato. Finitura F30 Design Centro Ricerche .
PESO: 3,5 kg - m³: 0,01
COLLI: 1

MEASURES: L 63 W 2,5 H 63
DESCRIPTION: Door for Zero composition and sideboards with cherry wood frame and tempered glass. Finishing: F30 Design by Centro Ricerche .
WEIGHT: 3,5 kg - m³: 0,01
PIECES: 1

ART. 3459
MODULO ZERO ANTA A LISTELLI

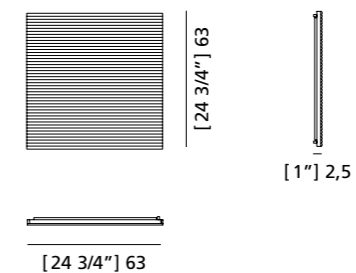

MISURE: L 63 P 2,5 H 63
DESCRIZIONE: anta per composizioni e credenze Zero in legno di ciliegio con fresatura a listelli. Finitura F30 Design Centro Ricerche .
PESO: 6,5 kg - m³: 0,01
COLLI: 1

MEASURES: L 63 W 2,5 H 63
DESCRIPTION: Door for Zero composition and sideboards made of cherry wood with a fine milling of wooden lists. Finishing: F30 Design by Centro Ricerche .
WEIGHT: 6,5 kg - m³: 0,01
PIECES: 1

ART. 3461
MODULO ZERO ANTA FRESATA

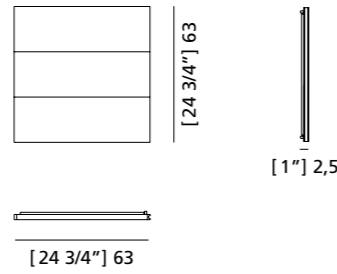

MISURE: L 63 P 2,5 H 63
DESCRIZIONE: anta per composizioni e credenze Zero in legno di ciliegio con doppia fresatura. Finitura F30 Design Centro Ricerche MAMM
PESO: 6,5 kg - m³: 0,01
COLLI: 1

MEASURES: L 63 W 2,5 H 63
DESCRIPTION: door for Zero composition and sideboards made of cherry wood with a fine milling which divides the surface in three parts. Finishing: F30 Design by Centro Ricerche MAMM
WEIGHT: 6,5 kg - m³: 0,01
PIECES: 1

ART. 3463
MODULO ZERO ANTA FINESTRA

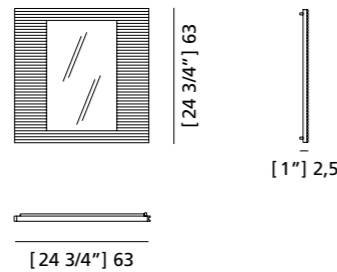

MISURE: L 63 P 2,5 H 63
DESCRIZIONE: anta per composizioni e credenze Zero in legno di ciliegio con fresatura a listelli e finestra centrale in vetro temperato. Finitura F30 Design Centro Ricerche MAMM
PESO: 6,5 kg - m³: 0,01
COLLI: 1

MEASURES: L 63 W 2,5 H 63
DESCRIPTION: door for Zero composition and sideboards made of cherry wood with fine milling and tempered glass. Finishing: F30 Design by Centro Ricerche MAMM
WEIGHT: 6,5 kg - m³: 0,01
PIECES: 1

ART. 3464
MODULO ZERO ANTA ONDA

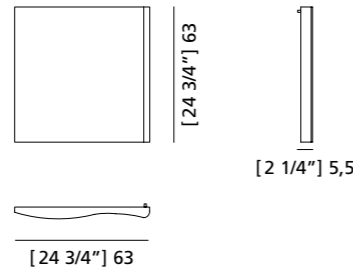

MISURE: L 63 P 5,5 H 63
DESCRIZIONE: anta per composizioni e credenze Zero in legno di ciliegio con sagomatura ad onda. Finitura F30 Design Centro Ricerche MAMM
PESO: 6,5 kg - m³: 0,02
COLLI: 1

MEASURES: L 63 W 5,5 H 63
DESCRIPTION: door for Zero composition and sideboards made of cherry wood with "wave" shape. Finishing: F30 Design by Centro Ricerche MAMM
WEIGHT: 6,5 kg - m³: 0,02
PIECES: 1

ART. 3466
MODULO ZERO ANTA ARCO

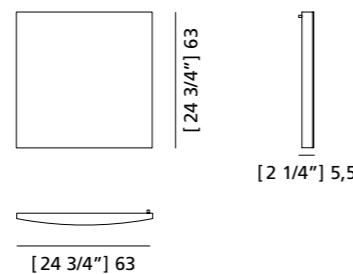

MISURE: L 63 P 5,5 H 63
DESCRIZIONE: anta per composizioni e credenze Zero in legno di ciliegio con sagomatura ad arco. Finitura F30 Design Centro Ricerche MAMM
PESO: 6 kg - m³: 0,02
COLLI: 1

MEASURES: L 63 W 5,5 H 63
DESCRIPTION: door for Zero composition and sideboards made of cherry wood with "arch" shape. Finishing: F30 Design by Centro Ricerche MAMM
WEIGHT: 6 kg - m³: 0,02
PIECES: 1

ART. 3440
MODULO ZERO ANTA CODE

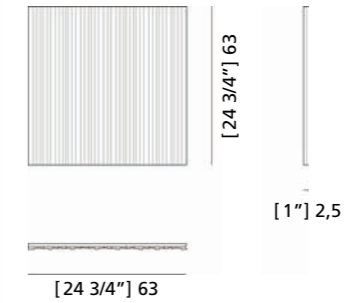

MISURE: L 63 P 2,5 H 63
DESCRIZIONE: anta per composizioni e credenze Zero con fresatura a listelli su legno massello di noce, acero e toulipier. Finitura F32 Design Centro Ricerche MAMM
PESO: 6,5 kg - m³: 0,01
COLLI: 1

MEASURES: L 63 W 2,5 H 63
DESCRIPTION: door for Zero composition and sideboards consists of a fine milling of wooden lists of solid walnut, cherry and tulipwood. Finishing: F32 Design by Centro Ricerche MAMM
WEIGHT: 6,5 kg - m³: 0,01
PIECES: 1

ART. 3497
MODULO ZERO ANTA COLORATA

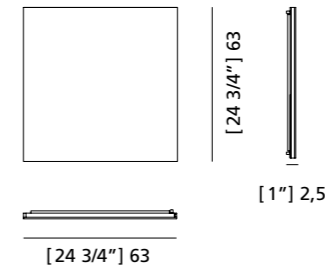

MISURE: L 63 P 2,5 H 63
DESCRIZIONE: anta per composizioni e credenze Zero in legno di ciliegio colorato. Design Centro Ricerche MAMM
PESO: 6 kg - m³: 0,01
COLLI: 1

MEASURES: L 63 W 2,5 H 63
DESCRIPTION: door for Zero composition and sideboards made of cherry wood with smooth surface. Design by Centro Ricerche MAMM
WEIGHT: 6 kg - m³: 0,01
PIECES: 1

ART. 3495
MODULO ZERO STRUTTURA 3 CASSETTI

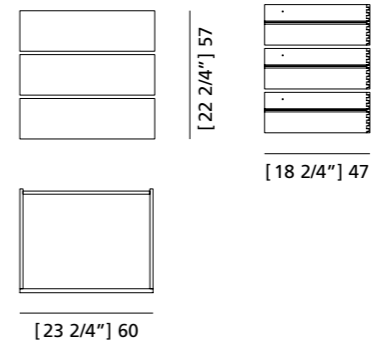

MISURE: L 60 P 47 H 57
DESCRIZIONE: struttura 3 cassetti per moduli e credenze Zero profondità 53cm su cui applicare anta 3454, 3459, 3461, 3464, 3466, 3440, 3497. Design Centro Ricerche MAMM
PESO: 15 kg - m³: 0,16
COLLI: 1

MEASURES: L 60 W 47 H 57
DESCRIPTION: chest of drawers for Zero elements and sideboards with depth 53 cm on which to apply doors 3454, 3459, 3461, 3464, 3466, 3440, 3497. Design by Centro Ricerche MAMM
WEIGHT: 15 kg - m³: 0,16
PIECES: 1

ART. 3491
MODULO ZERO STRUTTURA

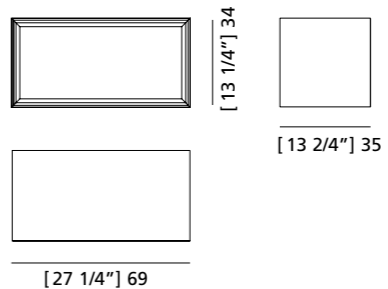

MISURE: L 69 P 35 H 34
DESCRIZIONE: elemento modulare per composizione Zero in legno di ciliegio, 1 vano. Finitura F32 Design Centro Ricerche MAMM
PESO: 13 kg - m³: 0,1
COLLI: 1

MEASURES: L 69 W 35 H 34
DESCRIPTION: modular element for Zero composition made of cherry wood, 1 compartment. Finishing: F32 Design by Centro Ricerche MAMM
WEIGHT: 13 kg - m³: 0,1
PIECES: 1

ART. 3477
MODULO ZERO STRUTTURA

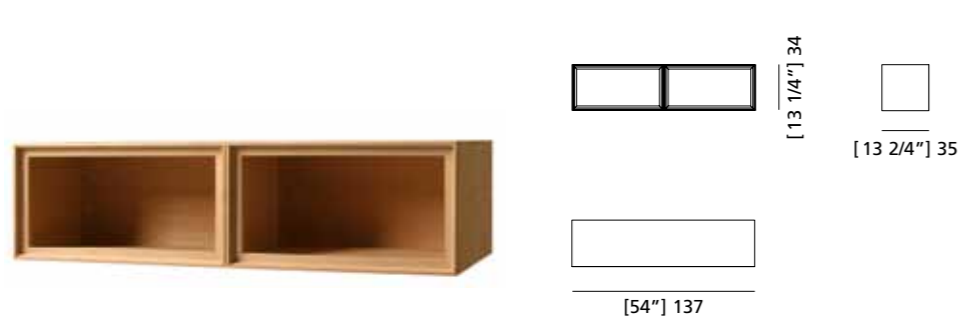

MISURE: L 137 P 35 H 34
DESCRIZIONE: elemento modulare per composizione Zero in legno di ciliegio, 2 vani. Finitura F32
Design Centro Ricerche MAMM
PESO: 25 kg - m³: 0,2
COLLI: 1

MEASURES: L 137 W 35 H 34
DESCRIPTION: Modular element for Zero composition made of cherry wood, 2 compartments. Finishing: F32
Design by Centro Ricerche MAMM
WEIGHT: 25 kg - m³: 0,2
PIECES: 1

ART. 3479
MODULO ZERO STRUTTURA

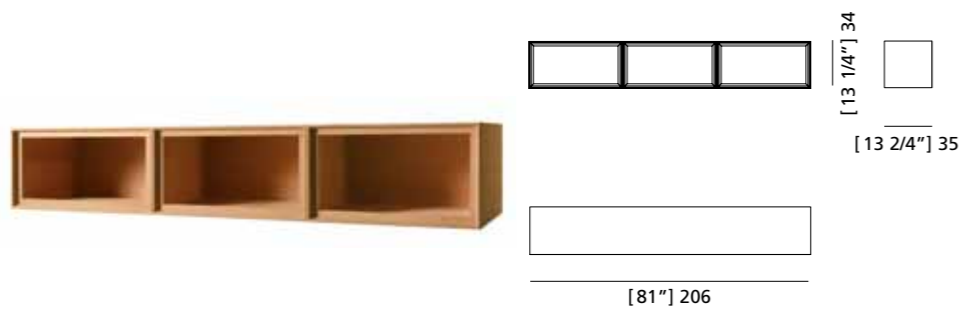

MISURE: L 206 P 35 H 34
DESCRIZIONE: elemento modulare per composizione Zero in legno di ciliegio, 3 vani. Finitura F32
Design Centro Ricerche MAMM
PESO: 43 kg - m³: 0,3
COLLI: 1

MEASURES: L 206 W 35 H 34
DESCRIPTION: modular element for Zero composition made of cherry wood, 3 compartments. Finishing: F32
Design by Centro Ricerche MAMM
WEIGHT: 43 kg - m³: 0,3
PIECES: 1

ART. 3492
MODULO ZERO STRUTTURA



MISURE: L 69 P 53 H 34
DESCRIZIONE: Elemento modulare per composizione Zero in legno di ciliegio, 1 vano. Finitura F32
Design Centro Ricerche MAMM
PESO: 18 kg - m³: 0,14
COLLI: 1

MEASURES: L 69 W 53 H 34
DESCRIPTION: Modular element for Zero composition made of cherry wood, 1 compartment. Finishing: F32
Design by Centro Ricerche MAMM
WEIGHT: 18 kg - m³: 0,14
PIECES: 1

ART. 3481
MODULO ZERO STRUTTURA

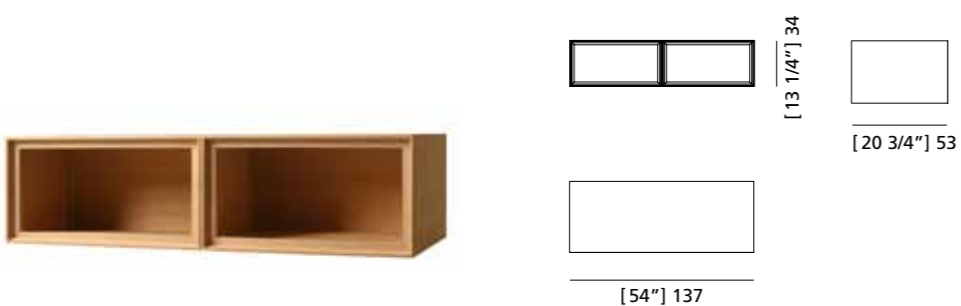

MISURE: L 137 P 53 H 34
DESCRIZIONE: elemento modulare per composizione Zero in legno di ciliegio, 2 vani. Finitura F32
Design Centro Ricerche MAMM
PESO: 30 kg - m³: 0,39
COLLI: 1

MEASURES: L 137 W 53 H 34
DESCRIPTION: Modular element for Zero composition made of cherry wood, 2 compartments. Finishing: F32
Design by Centro Ricerche MAMM
WEIGHT: 30 kg - m³: 0,39
PIECES: 1

ART. 3476
MODULO ZERO STRUTTURA

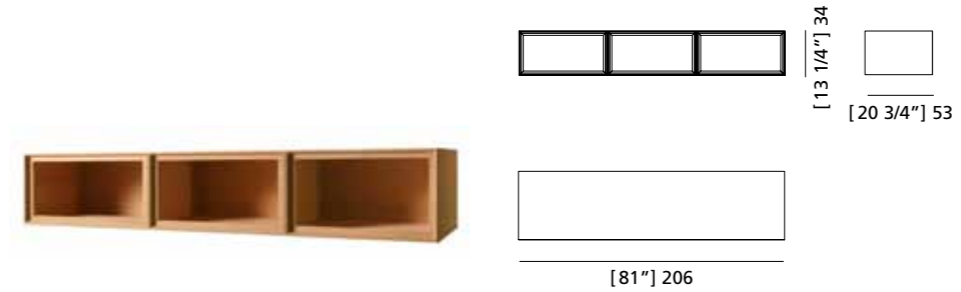

MISURE: L 206 P 53 H 34
DESCRIZIONE: elemento modulare per composizione Zero in legno di ciliegio, 3 vani. Finitura F32
Design Centro Ricerche MAMM
PESO: 50 kg - m³: 0,46
COLLI: 1

MEASURES: L 206 W 53 H 34
DESCRIPTION: modular element for Zero composition made of cherry wood, 3 compartments. Finishing: F32
Design by Centro Ricerche MAMM
WEIGHT: 50 kg - m³: 0,46
PIECES: 1

ART. 3455
MODULO ZERO ANTA MATTONCINI



MISURE: L 63 P 2,5 H 28,5
DESCRIZIONE: anta per composizioni e credenze Zero in legno di ciliegio con pregiato intarsio in ebano tinto a forma di mattoni. Finitura: F60
Design Centro Ricerche MAMM
PESO: 3,5 kg - m³: 0,01
COLLI: 1

MEASURES: L 63 W 2,5 H 28,5
DESCRIPTION: door for Zero composition and sideboards made of cherry wood with "bricks" shape by ebony inlay Finishing: F60
Design by Centro Ricerche MAMM
WEIGHT: 3,5 kg - m³: 0,01
PIECES: 1

ART. 3458
MODULO ZERO ANTA VETRO

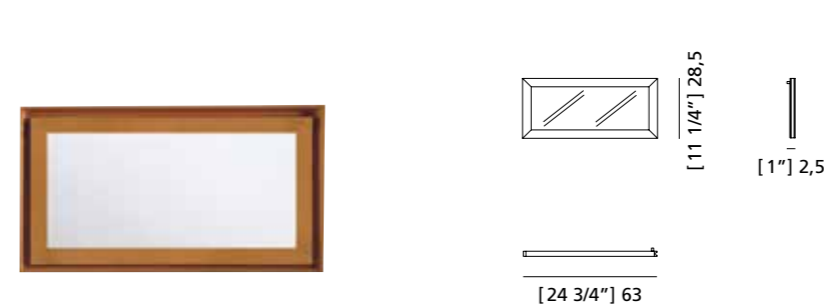

MISURE: L 63 P 2,5 H 28,5
DESCRIZIONE: anta per composizioni e credenze Zero con cornice in legno massello di ciliegio e vetro temperato. Finitura F30
Design Centro Ricerche MAMM
PESO: 2,5 kg - m³: 0,01
COLLI: 1

MEASURES: L 63 W 2,5 H 28,5
DESCRIPTION: door for Zero composition and sideboards with cherry wood frame and tempered glass. Finishing: F30
Design by Centro Ricerche MAMM
WEIGHT: 2,5 kg - m³: 0,01
PIECES: 1

ART. 3460
MODULO ZERO ANTA LISTELLI

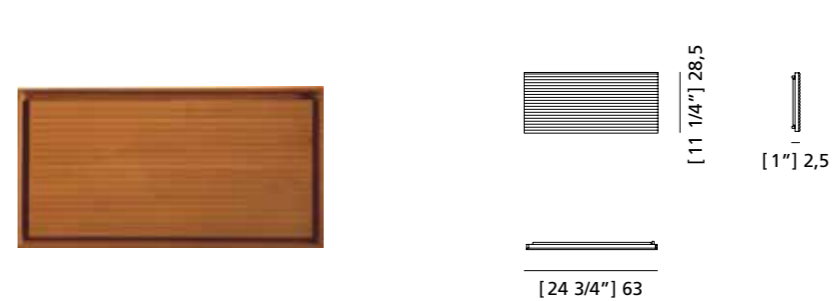

MISURE: L 63 P 2,5 H 28,5
DESCRIZIONE: anta per composizioni e credenze Zero in legno di ciliegio con fresatura a listelli. Finitura F30
Design Centro Ricerche MAMM
PESO: 3,5 kg - m³: 0,01
COLLI: 1

MEASURES: L 63 W 2,5 H 28,5
DESCRIPTION: door for Zero composition and sideboards made of cherry wood with a fine milling of wooden lists. Finishing: F30
Design by Centro Ricerche MAMM
WEIGHT: 3,5 kg - m³: 0,01
PIECES: 1

ART. 3441
MODULO ZERO ANTA CODE

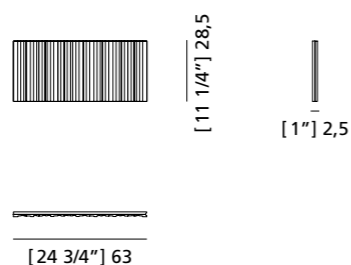

MISURE: L 63 P 2,5 H 28,5
DESCRIZIONE: anta per composizioni e credenze Zero con fresatura a listelli su legno massello di noce, acero e toupilier. Finitura F32
Design Centro Ricerche MAM
PESO: 3,5 kg - m³: 0,01
COLLI: 1

MEASURES: L 63 W 2,5 H 28,5
DESCRIPTION: door for Zero composition and sideboards consists of a fine milling of wooden lists of solid walnut, cherry and tulipwood. Finishing: F32
Design by Centro Ricerche MAM
WEIGHT: 3,5 kg - m³: 0,01
PIECES: 1

ART. 3498
MODULO ZERO ANTA COLORATA

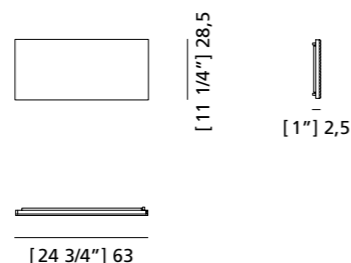

MISURE: L 63 P 2,5 H 28,5
DESCRIZIONE: anta per composizioni e credenze Zero in legno di ciliegio colorato. Design Centro Ricerche MAM
PESO: 3,5 kg - m³: 0,01
COLLI: 1

MEASURES: L 63 W 2,5 H 28,5
DESCRIPTION: door for Zero composition and sideboards made of colored cherry wood with smooth surface.
Design by Centro Ricerche MAM
WEIGHT: 3,5 kg - m³: 0,01
PIECES: 1

ART. 3486
MODULO ZERO STRUTTURA 1 CASSETTO

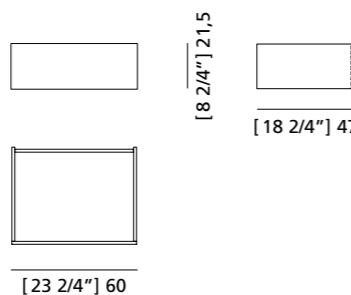

MISURE: L 60 P 47 H 21,5
DESCRIZIONE: struttura cassetto per moduli Zero profondità 53cm su cui applicare anta 3455, 3460, 3441, 3498
Design Centro Ricerche MAM
PESO: 5 kg - m³: 0,07
COLLI: 1

MEASURES: L 60 W 47 H 21,5
DESCRIPTION: drawer for Zero elements and sideboards with depth 53 cm on which to apply doors 3455, 3460, 3441, 3498
Design by Centro Ricerche MAM
WEIGHT: 5 kg - m³: 0,07
PIECES: 1

ART. 3473
MODULO ZERO ELEMENTO SCRITTOIO

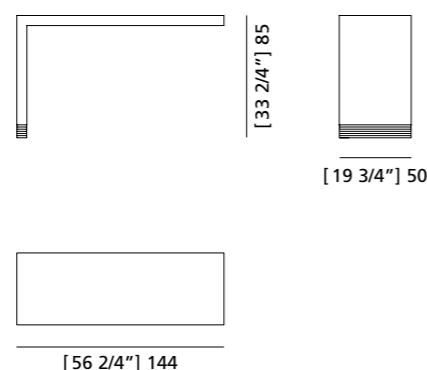

MISURE: L 144 P 50 H 85
DESCRIZIONE: elemento scrittoio in legno di ciliegio per composizioni e credenze Zero. Finitura F30
Design Centro Ricerche MAM
PESO: 20 kg - m³: 0,75
COLLI: 1

MEASURES: L 144 W 50 H 85
DESCRIPTION: writing desk element made of cherry wood for Zero compositions and sideboards. Finishing: F30
Design by Centro Ricerche MAM
WEIGHT: 20 kg - m³: 0,75
PIECES: 1

ART. 3437
MODULO ZERO MENSOLA

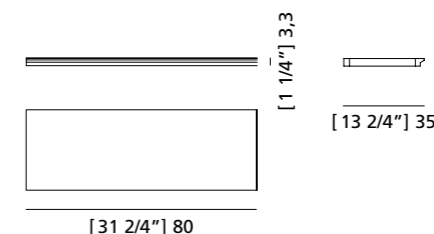

MISURE: L 80 P 35 H 3,3
DESCRIZIONE: mensola per composizioni Zero in legno di ciliegio. Disponibile a misura. Finitura F32
Design Centro Ricerche MAM
PESO: 8 kg - m³: 0,01
COLLI: 1

MEASURES: L 80 W 35 H 3,3
DESCRIPTION: shelf for Zero compositions. Finishing: F32
Design by Centro Ricerche MAM
WEIGHT: 8 kg - m³: 0,01
PIECES: 1

ART. 3432
MODULO ZERO PANNELLO BOISERIE

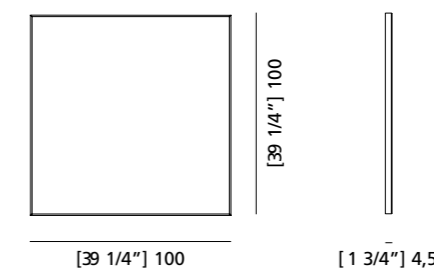

MISURE: L 100 P 4,5 H 100
DESCRIZIONE: pannello boiserie in legno di ciliegio per composizioni Zero su misura. Finitura F30
Design Centro Ricerche MAM
PESO: 18 kg - m³: 0,11
COLLI: 1

MEASURES: L 100 W 4,5 H 100
DESCRIPTION: boiserie panel made of cherry wood for Zero compositions. Finishing: F30
Design by Centro Ricerche MAM
WEIGHT: 18 kg - m³: 0,11
PIECES: 1

ART. 3468
MODULO ZERO BASE CAVALLETTO

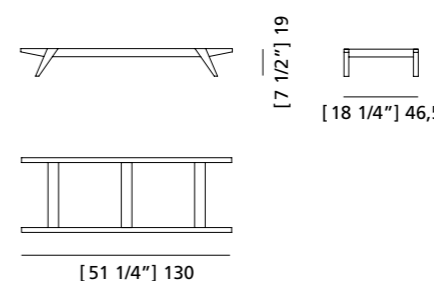

MISURE: L 130 P 46,5 H 19
DESCRIZIONE: elemento base con piedini per composizioni e credenze zero in legno massello di ciliegio. Disponibile a misura. Design Centro Ricerche MAM
PESO: 3 kg - m³: 0,01
COLLI: 1

MEASURES: L 130 W 46,5 H 19
DESCRIPTION: base element with legs for Zero compositions and sideboards made of cherry wood.
Design by Centro Ricerche MAM
WEIGHT: 9 kg - m³: 0,13
PIECES: 1

ART. 3474
MODULO ZERO BASE CAVALLETTO

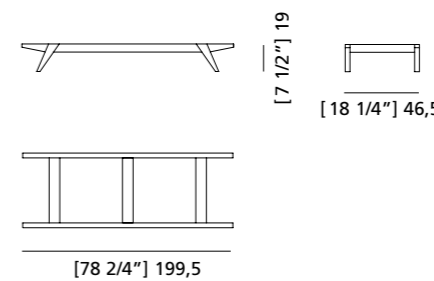

MISURE: L 199,5 P 46,5 H 19
DESCRIZIONE: elemento base con piedini per composizioni e credenze zero in legno massello di ciliegio. Disponibile a misura. Design Centro Ricerche MAM
PESO: 15 kg - m³: 0,2
COLLI: 1

MEASURES: L 199,5 W 46,5 H 19
DESCRIPTION: base element with legs for Zero compositions and sideboards made of cherry wood.
Design by Centro Ricerche MAM
WEIGHT: 15 kg - m³: 0,2
PIECES: 1

ART. 3469
MODULO ZERO BASE ARCO

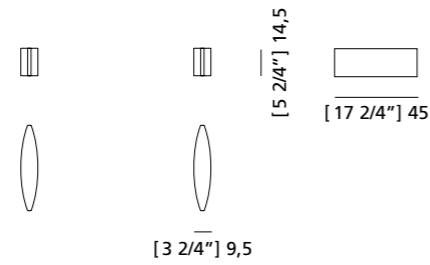

MISURE: L 9,5 P 45 H 14,5
DESCRIZIONE: elemento base per composizioni e credenze Zero.
Finitura F32
Design Centro Ricerche MAAM
PESO: 5 kg - m³: 0,01
COLLI: 1

MEASURES: L 9,5 W 45 H 14,5
DESCRIPTION: base element for Zero compositions and sideboards made of cherry wood. Finishing: F32
Design by Centro Ricerche MAAM
WEIGHT: 5 kg - m³: 0,01
PIECES: 1

ART. 3429
MODULO ZERO BASE

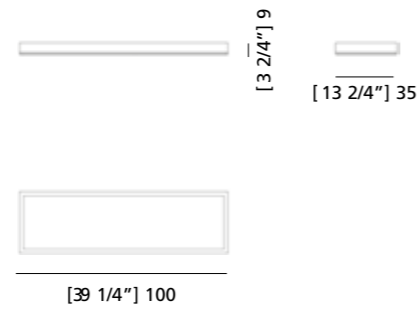

MISURE: L 100 P 35 H 9
DESCRIZIONE: elemento base a zoccolo per composizioni e credenze Zero, disponibile a misura.
Design Centro Ricerche MAAM
PESO: 4 kg - m³: 0,04
COLLI: 1

MEASURES: L 100 W 35 H 9
DESCRIPTION: base element for Zero compositions and sideboards made of cherry wood.
Design by Centro Ricerche MAAM
WEIGHT: 4 kg - m³: 0,04
PIECES: 1

ART. 3496
MODULO ZERO BASE

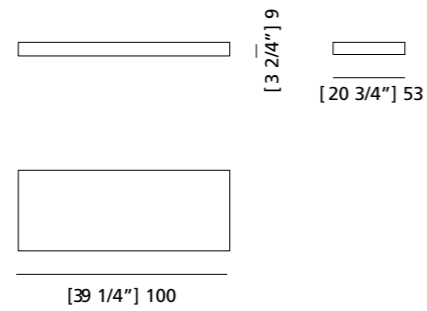

MISURE: L 100 P 53 H 9
DESCRIZIONE: elemento base a zoccolo per composizioni e credenze Zero, disponibile a misura.
Design Centro Ricerche MAAM
PESO: 6 kg - m³: 0,25
COLLI: 1

MEASURES: L 100 W 53 H 9
DESCRIPTION: base element for Zero compositions and sideboards made of cherry wood.
Design by Centro Ricerche MAAM
WEIGHT: 6 kg - m³: 0,25
PIECES: 1

FIANCHI SCALETTA

ART. 3445



MISURE: / MEASURES:
H 87 (34 1/4")
P 3 (1 1/5")
L 43 (16 7/8")

ART. 3453



MISURE: / MEASURES:
H 180 (70 7/8")
P 3 (1 1/5")
L 43 (16 7/8")

PIEDE IN ACCIAIO

ART. A010142S



ART. A010141S



PIEDE IN OTTONE

ART. A010161S





ART. FS3314337
COMPOSIZIONE NOVECENTO

CUSTOMIZABLE

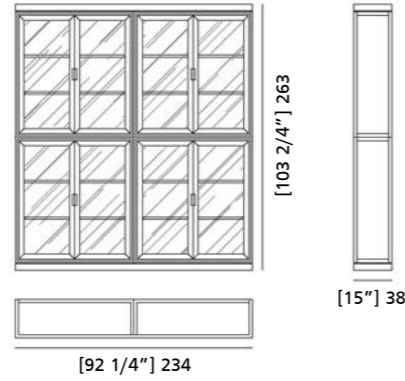

MISURE: L 234 P 38 H 263
DESCRIZIONE: libreria in legno di frassino formata da 4 moduli con ante in vetro a battente con maniglie in ottone. I ripiani interni, regolabili in altezza, si scostano dagli schienali per permettere l'inserimento di luci a led. Design Centro Ricerche MAAM
PESO: 200 kg - m³: 2 - COLLI: 5

MEASURES: L 234 W 38 H 263
DESCRIPTION: ash wood bookcase made of 4 modules with hinged glass doors with brass handles. The internal shelves, adjustable in height, move from the backrests to allow the insertion of led lights. Design by Centro Ricerche MAAM
WEIGHT: 200kg - m³: 2 - PIECES: 5

ART. FS3314322
COMPOSIZIONE NOVECENTO

CUSTOMIZABLE

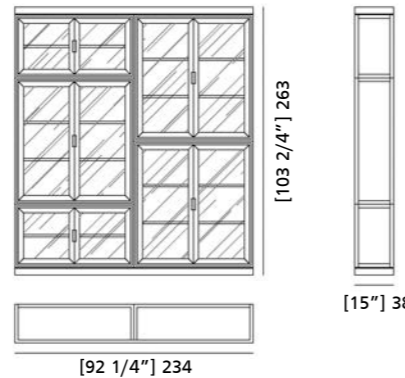
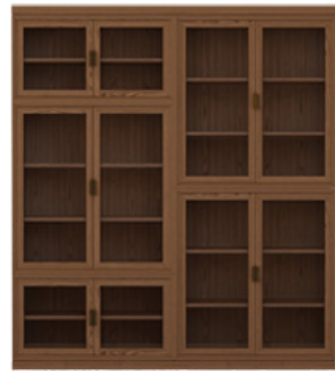

MISURE: L 234 P 38 H 263
DESCRIZIONE: Composizione in stile Novecento formata da due moduli base con ante a vetro, due moduli alzata con ante a vetro, un sopralzo con ante a vetro. I ripiani interni, regolabili in altezza, si scostano dagli schienali per permettere l'inserimento di luci a led. Design Centro Ricerche MAAM
PESO: 200 kg - m³: 2 - COLLI: 6

MEASURES: L 234 W 38 H 263
DESCRIPTION: Novecento composition made of two basic modules with glass doors, two raised modules with glass doors, a top unit with glass doors. The internal shelves, adjustable in height, move from the backrests to allow the insertion of led lights. Design by Centro Ricerche MAAM
WEIGHT: 200kg - m³: 2 - PIECES: 5

ART. FS3314320
COMPOSIZIONE NOVECENTO

CUSTOMIZABLE

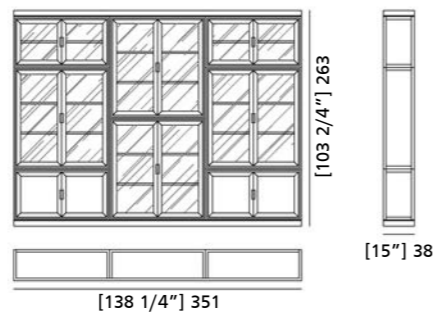

MISURE: L 351 P 38 H 263
DESCRIZIONE: Composizione in stile Novecento formata da due moduli base con ante a legno, un modulo base con ante a vetro, tre moduli alzata con ante a vetro e due sopralzi con ante a vetro. I ripiani interni, regolabili in altezza, si scostano dagli schienali per permettere l'inserimento di luci a led. Design Centro Ricerche MAAM
PESO: 290 kg - m³: 3 - COLLI: 9

MEASURES: L 351 W 38 H 263
DESCRIPTION: Novecento composition made of two basic modules with wood doors, one basic module with glass door, three raised modules with glass doors, two top units with glass doors. The internal shelves, adjustable in height, move from the backrests to allow the insertion of led lights. Design by Centro Ricerche MAAM
WEIGHT: 290kg - m³: 3 - PIECES: 9

ART. 3360/F
BASE NOVECENTO

CUSTOMIZABLE

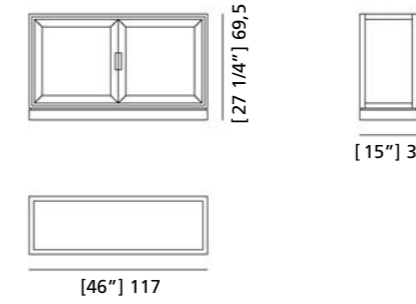

MISURE: L 117 P 38 H 69,5
DESCRIZIONE: Base per libreria componibile in legno di Frassino, con ante in legno, vetro o pelle e maniglia in ottone
PESO: 40 kg - m³: 0,4
COLLI: 1

MEASURES: L 117 P 38 H 69,5
DESCRIPTION: Base for modular bookcase made of Ash wood, with wooden, glass or leather doors, and brass handles
WEIGHT: 40 kg - m³: 0,4
PIECES: 1

ART. 3361/F
BASE ALTA NOVECENTO

CUSTOMIZABLE

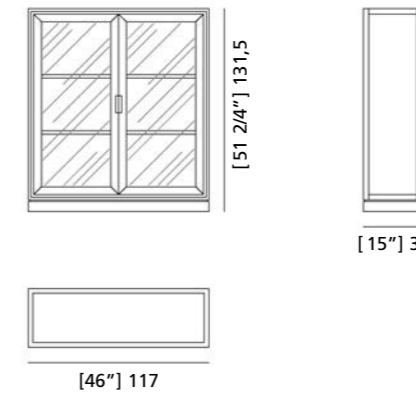

MISURE: L 117 P 38 H 131,5
DESCRIZIONE: Base per libreria componibile in legno di Frassino, con ante in vetro e maniglia in ottone. Predisposizione Led interno
PESO: 70 kg - m³: 0,7
COLLI: 1

MEASURES: L 117 P 38 H 131,5
DESCRIPTION: Base for modular bookcase made of Ash wood, with glass doors, and brass handles. Led light predisposition.
WEIGHT: 70 kg - m³: 0,7
PIECES: 1

ART. 3362/F
ALZATA NOVECENTO

CUSTOMIZABLE

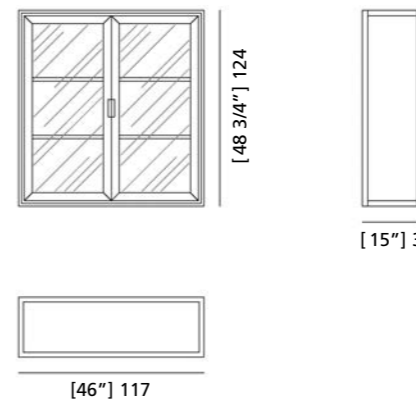

MISURE: L 117 P 38 H 124
DESCRIZIONE: Alzata per libreria componibile in legno di Frassino, con ante in vetro e maniglia in ottone. Predisposizione Led interno
PESO: 62 kg - m³: 0,6
COLLI: 1

MEASURES: L 117 P 38 H 124
DESCRIPTION: Upper element for modular bookcase made of Ash wood, with glass doors, and brass handles. Led light predisposition.
WEIGHT: 62 kg - m³: 0,6
PIECES: 1

ART. 3363/F
ALZATA A GIORNO NOVECENTO

CUSTOMIZABLE

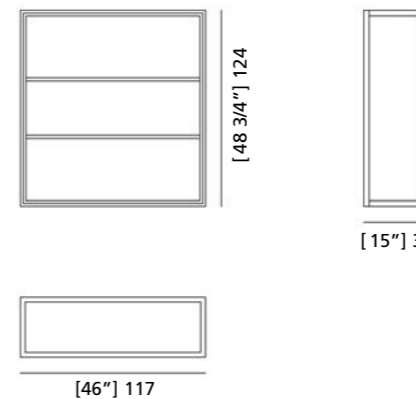

MISURE: L 117 P 38 H 124
DESCRIZIONE: Alzata a giorno per libreria componibile in legno di Frassino. Predisposizione Led interno
PESO: 48 kg - m³: 0,6
COLLI: 1

MEASURES: L 117 P 38 H 124
DESCRIPTION: Upper element for modular open bookcase made of Ash wood. Led light predisposition.
WEIGHT: 48 kg - m³: 0,6
PIECES: 1

ART. 3364/F
SOPRALZO A VETRO NOVECENTO

CUSTOMIZABLE

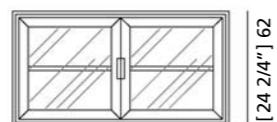

MISURE: L 117 P 38 H 62
DESCRIZIONE: Sopralzo per libreria componibile in legno di Frassino, con ante in vetro e maniglia in ottone. Predisposizione Led interno
PESO: 32 kg - m³: 0,3
COLLI: 1

MEASURES: L 117 P 38 H 62
DESCRIPTION: Upper element for modular bookcase made of Ash wood, with glass doors, and brass handles. Led light predisposition.
WEIGHT: 32 kg - m³: 0,3
PIECES: 1

ART. 3365/F
SOPRALZO A GIORNO NOVECENTO

CUSTOMIZABLE



MISURE: L 117 P 38 H 62
DESCRIZIONE: Sopralzo a giorno per libreria componibile in legno di Frassino. Predisposizione Led interno
PESO: 25 kg - m³: 0,3
COLLI: 1

MEASURES: L 117 P 38 H 62
DESCRIPTION: Upper element for modular open bookcase made of Ash wood. Led light predisposition.
WEIGHT: 25 kg - m³: 0,3
PIECES: 1

ART. 3366/F
CORNICE AL MT.L

CUSTOMIZABLE



MISURE: L 117 P 38 H 7,5
DESCRIZIONE: Cornice a misura per libreria componibile
PESO: 8 kg - COLLI: 1

MEASURES: L 117 P 38 H 7,5
DESCRIPTION: Frame for modular bookcase
WEIGHT: 8 kg - PIECES: 1

ART. 3367/F
BASAMENTO AL MT.L

CUSTOMIZABLE



MISURE: L 117 P 38 H 7,5
DESCRIZIONE: Basamento a misura per libreria componibile
PESO: 8 kg - COLLI: 1

MEASURES: L 117 P 38 H 7,5
DESCRIPTION: Base for modular bookcase
WEIGHT: 8 kg - PIECES: 1

ART. A0102275
LUCE LED PER MODULO NOVECENTO ART. 3362/F

ART. A0102285
LUCE LED PER MODULO NOVECENTO ART. 3364/F

TRASFORMATORE E DRIVER MODULO NOVECENTO



ART. FS379725
COMPOSIZIONE BIEDERMEIER

CUSTOMIZABLE

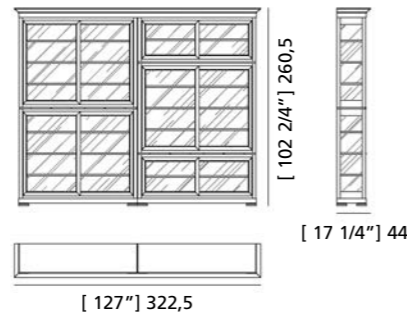

MISURE: L 322,5 P 44 H 260,5
DESCRIZIONE: proposta di Libreria Biedermeier componibile in legno di ciliegio. 5 moduli sovrapponibili e accostabili con ante scorrevoli a vetro temperato e ripiani regolabili su scaletta di legno. Tiretti a scomparsa tra i moduli sovrapposti. Su richiesta: Legno di noce canaletto; fianchi a vetro o legno; illuminazione interna a LED. Finiture: esterna F34, interna FL10. Design centro Ricerche MAMM
PESO: 360 kg - m³: 4,8 - COLLI: 18

MEASURES: L 322,5 P 44 H 260,5
DESCRIPTION: proposal for Biedermeier modular bookcase in cherry wood. 5 modular elements with tempered glass sliding doors and adjustable shelves on wooden support. Hidden extensions between the overlapped elements. Glass sides. Upon request: walnut wood, glass or wooden sides, LED interior lighting. Finishing: F34 external, internal FL10. Design: centro Ricerche MAMM
WEIGHT: 360 kg - m³: 4,8 - PIECES: 18

ART. FS3710182
COMPOSIZIONE BIEDERMEIER

CUSTOMIZABLE

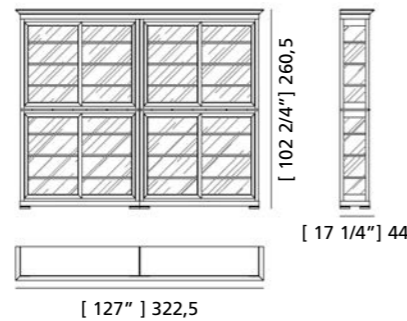

MISURE: L 322,5 P 44 H 260,5
DESCRIZIONE: proposta di Libreria Biedermeier componibile in legno di ciliegio. 4 moduli sovrapponibili e accostabili con ante scorrevoli a vetro temperato e ripiani regolabili su scaletta di legno. Tiretti a scomparsa tra i moduli sovrapposti. Su richiesta: Legno di noce canaletto; fianchi a vetro o legno; illuminazione interna a LED. Finiture: esterna F34, interna FL10. Design centro Ricerche MAMM
PESO: 370 kg - m³: 4,5 - COLLI: 17

MEASURES: L 322,5 P 44 H 260,5
DESCRIPTION: proposal for Biedermeier modular bookcase in cherry wood. 4 modular elements with tempered glass sliding doors and adjustable shelves on wooden support. Hidden extensions between the overlapped elements. Glass sides. Upon request: walnut wood, glass or wooden sides, LED interior lighting. Finishing: F34 external, internal FL10. Design Centro Ricerche MAMM
WEIGHT: 370 kg - m³: 4,5 - PIECES: 17

ART. 3708
MODULO BIEDERMEIER

CUSTOMIZABLE

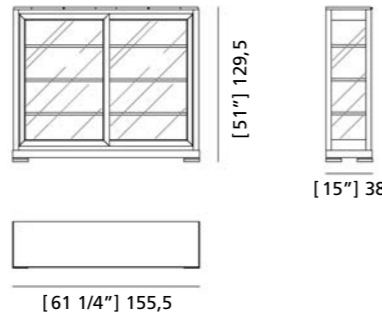

MISURE: L 155,5 P 38 H 129,5
DESCRIZIONE: modulo con base per Libreria Biedermeier componibile in legno di ciliegio, con 2 ante scorrevoli a vetro temperato, 6 ripiani regolabili su scaletta di legno, fianchi a vetro e due tiretti a scomparsa. Su richiesta: noce canaletto, fianchi in legno, luci LED interne. Finiture: esterna F34, interna FL10. Design Centro Ricerche MAMM
PESO: 82 kg - m³: 1,15 - COLLI: 3

MEASURES: L 155,5 W 38 H 129,5
DESCRIPTION: base element for Biedermeier modular bookcase in cherry wood. 2 tempered glass sliding doors and adjustable shelves on wooden support. Hidden extensions under the top. Glass sides. Upon request: walnut wood, glass or wooden sides, LED interior lighting. Finishing: F34 external, internal FL10. Design Centro Ricerche MAMM
WEIGHT: 82 kg - m³: 1,15 - PIECES: 3

ART. 3709
MODULO BIEDERMEIER

CUSTOMIZABLE

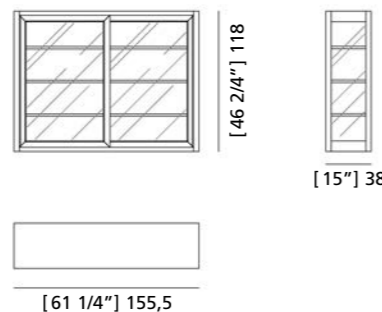

MISURE: L 155,5 P 38 H 118
DESCRIZIONE: modulo alzata per Libreria Biedermeier componibile in legno di ciliegio, con 2 ante scorrevoli a vetro temperato, 6 ripiani regolabili su scaletta di legno, fianchi a vetro. Su richiesta: noce canaletto, fianchi in legno, luci LED interne. Finiture: esterna F34, interna FL10. Design Centro Ricerche MAMM
PESO: 73 kg - m³: 1,05 - COLLI: 3

MEASURES: L 155,5 W 38 H 118
DESCRIPTION: upper element for Biedermeier modular bookcase in cherry wood. 2 tempered glass sliding doors and adjustable shelves on wooden support. Glass sides. Upon request: walnut wood, glass or wooden sides, LED interior lighting. Finishing: F34 external, internal FL10. Design Centro Ricerche MAMM
WEIGHT: 73 kg - m³: 1,05 - PIECES: 3

ART. 3721
MODULO BIEDERMEIER

CUSTOMIZABLE

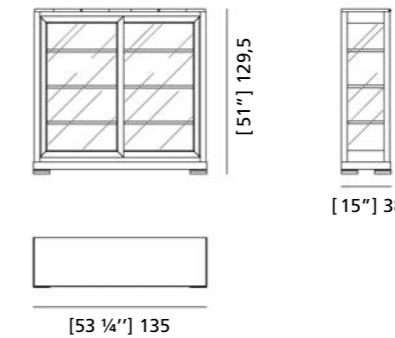

MISURE: L 135 P 38 H 129,5
DESCRIZIONE: modulo con base per Libreria Biedermeier componibile in legno di ciliegio, con 2 ante scorrevoli a vetro temperato, 6 ripiani regolabili su scaletta di legno, tiretti a scomparsa sotto il top e fianchi a vetro. Su richiesta: noce canaletto, fianchi in legno, luci LED interne. Finiture: esterna F34, interna FL10. Design Centro Ricerche MAMM
PESO: 85 kg - m³: 1 - COLLI: 3

MEASURES: L 135 W 38 H 129,5
DESCRIPTION: base element for Biedermeier modular bookcase in cherry wood. 2 tempered glass sliding doors and adjustable shelves on wooden support. Hidden extensions under the top. Glass sides. Upon request: walnut wood, glass or wooden sides, LED interior lighting. Finishing: F34 external, internal FL10. Design Centro Ricerche MAMM
WEIGHT: 85 kg - m³: 1 - PIECES: 3

ART. 3722
MODULO BIEDERMEIER

CUSTOMIZABLE

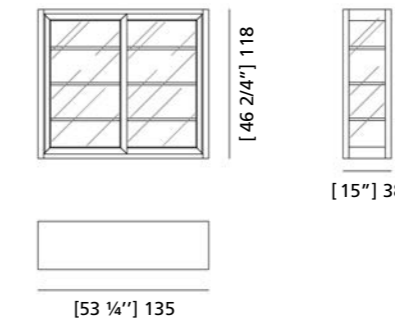

MISURE: L 135 P 38 H 118
DESCRIZIONE: modulo alzata per Libreria Biedermeier componibile in legno di ciliegio, con 2 ante scorrevoli a vetro temperato, 6 ripiani regolabili su scaletta di legno, fianchi a vetro. Su richiesta: noce canaletto, fianchi in legno, luci LED interne. Finiture: esterna F34, interna FL10. Design Centro Ricerche MAMM
PESO: 80 kg - m³: 0,9 - COLLI: 3

MEASURES: L 135 W 38 H 118
DESCRIPTION: Upper element for Biedermeier modular bookcase in cherry wood. 2 tempered glass sliding doors and adjustable shelves on wooden support. Glass sides. Upon request: walnut wood, glass or wooden sides, LED interior lighting. Finishing: F34 external, internal FL10. Design Centro Ricerche MAMM
WEIGHT: 80 kg - m³: 0,9 - PIECES: 3

ART. 3723
MODULO BIEDERMEIER PORTA TV

CUSTOMIZABLE

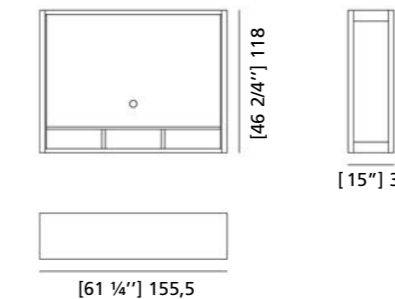

MISURE: L 155,5 P 38 H 118
DESCRIZIONE: modulo alzata per Libreria Biedermeier componibile in legno di ciliegio, ampio vano a giorno porta TV con tre compartimenti e passacavi. Su richiesta: noce canaletto. Design Centro Ricerche MAMM
PESO: 60 kg - m³: 0,8 - COLLI: 1

MEASURES: L 155,5 W 38 H 118
DESCRIPTION: Upper element for Biedermeier modular bookcase in cherry wood. A large open space for TV with 3 small compartments and fairleads. Upon request: walnut wood. Design Centro Ricerche MAMM
WEIGHT: 60 kg - m³: 0,8 - PIECES: 1

ART. 3712
MODULO BIEDERMEIER SOPRALZO

CUSTOMIZABLE

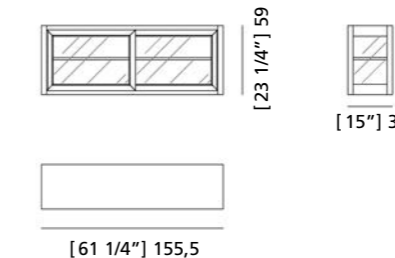

MISURE: L 155,5 P 38 H 59
DESCRIZIONE: modulo alzata per Libreria Biedermeier componibile in legno di ciliegio, con 2 ante scorrevoli a vetro temperato, 2 ripiani regolabili su scaletta di legno, fianchi a vetro. Su richiesta: noce canaletto, fianchi in legno, luci LED interne. Finiture: esterna F34, interna FL10. Design Centro Ricerche MAMM
PESO: 35 kg - m³: 0,45 - COLLI: 1

MEASURES: L 155,5 W 38 H 59
DESCRIPTION: Upper element for Biedermeier modular bookcase in cherry wood. 2 tempered glass sliding doors and adjustable shelves on wooden support. Glass sides. Upon request: walnut wood, glass or wooden sides, LED interior lighting. Finishing: F34 external, internal FL10. Design Centro Ricerche MAMM
WEIGHT: 35 kg - m³: 0,45 - PIECES: 1

ART. 3713
MODULO BIEDERMEIER BASE

CUSTOMIZABLE

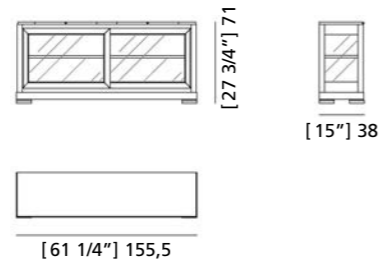

MISURE: L 155,5 P 38 H 71
DESCRIZIONE: modulo con base per Libreria Biedermeier componibile in legno di ciliegio, con 2 ante scorrevoli a vetro temperato, 2 ripiani regolabili su scaletta di legno, fianchi a vetro e due tiretti a scomparsa. Su richiesta: noce canaletto, fianchi in legno, luci LED interne. Finiture: esterna F34, interna FL10. Design Centro Ricerche MAMM PESO: 35 kg - m³: 0,5 - COLLI: 1

MEASURES: L 155,5 W 38 H 71
DESCRIPTION: base element for Biedermeier modular bookcase in cherry wood. 2 tempered glass sliding doors and adjustable shelves on wooden support. Hidden extensions under the top. Glass sides. Upon request: walnut wood, glass or wooden sides, LED interior lighting. Finishing: F34 external, internal FL10. Design Centro Ricerche MAMM PESO: 35 kg - m³: 0,5 - PIECES: 1

ART. 3714
MODULO BIEDERMEIER VETRINA

CUSTOMIZABLE

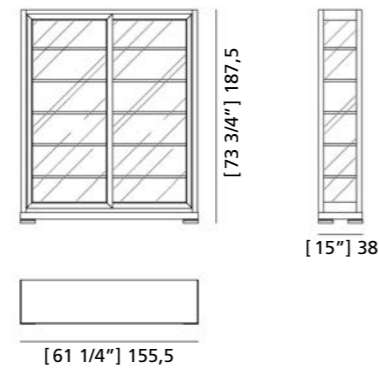

MISURE: L 155,5 P 38 H 187,5
DESCRIZIONE: modulo con base per Libreria Biedermeier componibile in legno di ciliegio, con 2 ante scorrevoli a vetro temperato, 10 ripiani regolabili su scaletta di legno, fianchi a vetro. Su richiesta: noce canaletto, fianchi in legno, luci LED interne. Finiture: esterna F34, interna FL10. Design Centro Ricerche MAMM PESO: 110 kg - m³: 1,5 - COLLI: 4

MEASURES: L 155,5 W 38 H 187,5
DESCRIPTION: base element for Biedermeier modular bookcase in cherry wood. 2 tempered glass sliding doors and adjustable shelves on wooden support. Hidden extensions under the top. Glass sides. Upon request: walnut wood, glass or wooden sides, LED interior lighting. Finishing: F34 external, internal FL10. Design Centro Ricerche MAMM PESO: 110 kg - m³: 1,5 - PIECES: 4

ART. 3731
MODULO BIEDERMEIER VETRINA

CUSTOMIZABLE

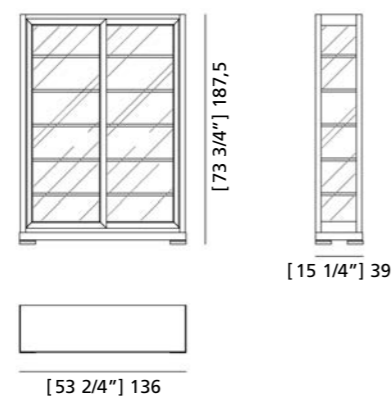

MISURE: L 136 P 39 H 187,5
DESCRIZIONE: Modulo base per Libreria Biedermeier componibile, in legno di ciliegio con due ante scorrevoli a vetro temperato, dieci ripiani interni regolabili su scaletta di legno, fianchi a vetro. Finiture: esterna F34, interna FL10. Design Centro Ricerche MAMM PESO: 90 kg - m³: 1,5 - COLLI: 1

MEASURES: L 136 P 39 H 187,5
DESCRIPTION: base element for Biedermeier modular bookcase in cherry wood. 2 tempered glass sliding doors and adjustable shelves on wooden support. Hidden extensions under the top. Glass sides. Upon request: walnut wood, glass or wooden sides, LED interior lighting. Finishing: F34 external, internal FL10. Design Centro Ricerche MAMM PESO: 90 kg - m³: 1,5 - PIECES: 1

ART. 3710
CORNICE AL METRO LINEARE

CUSTOMIZABLE

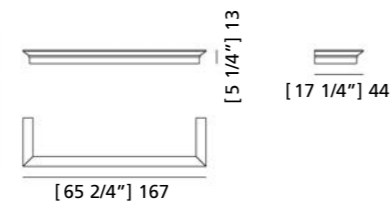

MISURE: L 167 P 44 H 13
DESCRIZIONE: cornice da applicare sull'alzata modulo Biedermeier Design Centro Ricerche MAMM PESO: 6 kg - m³: 0,12 - COLLI: 1

MEASURES: L 167 W 44 H 13
DESCRIPTION: top frame for the Biedermeier composition. Design Centro Ricerche MAMM PESO: 6 kg - m³: 0,12 - PIECES: 1

ART. 3711
PIANO AL METRO LINEARE

CUSTOMIZABLE

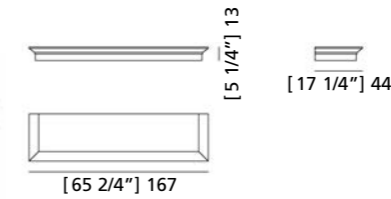

MISURE: L 167 P 44 H 13
DESCRIZIONE: piano da applicare alla base modulo Biedermeier. Design Centro Ricerche MAMM PESO: 12 kg - m³: 0,12 COLLI: 1

MEASURES: L 167 W 44 H 13
DESCRIPTION: top frame for the Biedermeier base unit. Design Centro Ricerche MAMM PESO: 12 kg - m³: 0,12 PIECES: 1

ART. 3727
MODULO BIEDERMEIER BASE

CUSTOMIZABLE

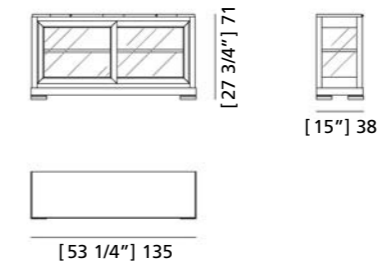

MISURE: L 135 P 38 H 71
DESCRIZIONE: modulo con base per Libreria Biedermeier componibile in legno di ciliegio, con 2 ante scorrevoli a vetro temperato, 2 ripiani regolabili su scaletta di legno, fianchi a vetro e due tiretti a scomparsa. Su richiesta: noce canaletto, fianchi in legno, luci LED interne. Finiture: esterna F34, interna FL10. Design Centro Ricerche MAMM PESO: 35 kg - m³: 0,5 - COLLI: 1

MEASURES: L 135 W 38 H 71
DESCRIPTION: base element for Biedermeier modular bookcase in cherry wood. 2 tempered glass sliding doors and adjustable shelves on wooden support. Hidden extensions under the top. Glass sides. Upon request: walnut wood, glass or wooden sides, LED interior lighting. Finishing: F34 external, internal FL10. Design Centro Ricerche MAMM PESO: 35 kg - m³: 0,5 - PIECES: 1

ART. 3728
MODULO BIEDERMEIER ALZATA

CUSTOMIZABLE

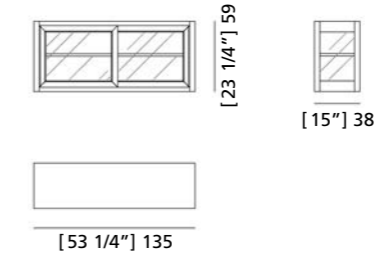

MISURE: L 135 P 38 H 59
DESCRIZIONE: modulo alzata per Libreria Biedermeier componibile in legno di ciliegio, con 2 ante scorrevoli a vetro temperato, 2 ripiani regolabili su scaletta di legno, fianchi a vetro. Su richiesta: noce canaletto, fianchi in legno, luci LED interne. Finiture: esterna F34, interna FL10. Design Centro Ricerche MAMM PESO: 35 kg - m³: 0,45 - COLLI: 1

MEASURES: L 135 W 38 H 59
DESCRIPTION: Upper element for Biedermeier modular bookcase in cherry wood. 2 tempered glass sliding doors and adjustable shelves on wooden support. Glass sides. Upon request: walnut wood, glass or wooden sides, LED interior lighting. Finishing: F34 external, internal FL10. Design Centro Ricerche MAMM PESO: 35 kg - m³: 0,45 - PIECES: 1

ART. 3729
MODULO BIEDERMEIER BASE

CUSTOMIZABLE

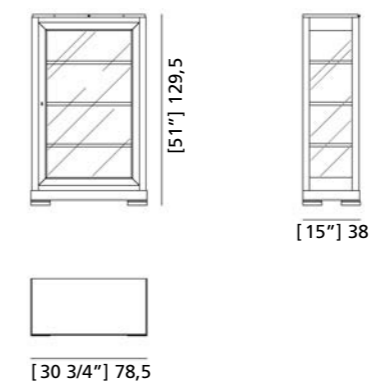

MISURE: L 78,5 P 38 H 129,5
DESCRIZIONE: modulo base per libreria biedermeier con anta battente. Design Centro Ricerche MAMM PESO: 35 kg - m³: 0,45 COLLI: 1

MEASURES: L 78,5 P 38 H 129,5
DESCRIPTION: Base element for Biedermeier bookcase with hinged door. Design Centro Ricerche MAMM PESO: 35 kg - m³: 0,45 PIECES: 1

ART. 3730
MODULO BIEDERMEIER ALZATA

CUSTOMIZABLE

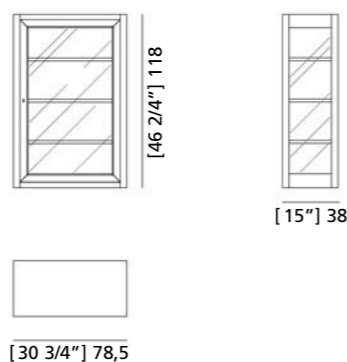

MISURE: L 78,5 P 38 H 118
DESCRIZIONE: modulo base per libreria biedermeier con anta battente.
Design Centro Ricerche ^{NAM}
PESO: 35 kg - m³: 0,5 - **COLLI:** 1

MEASURES: L 78,5 P 38 H 118
DESCRIPTION: Base element for Biedermeier bookcase with hinged door.
Design Centro Ricerche ^{NAM}
WEIGHT: 35 kg - m³: 0,5 - **PIECES:** 1

ART.3345
ELEMENTO SCALA

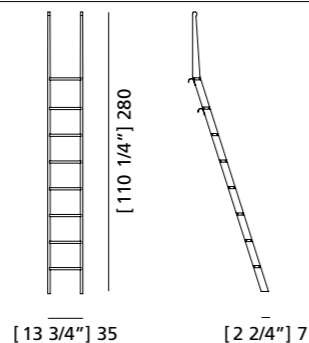

MISURE: L 35 P 7 H 280
DESCRIZIONE: elemento scala per composizioni a doppia altezza.
PESO: 8 kg - m³: 0,02
COLLI: 1

MEASURES: L 35 P 7 H 280
DESCRIPTION: ladder for compositions with double height.
WEIGHT: 8 kg - m³: 0,02
PIECES: 1

ART. A010180S
BARRA TUBOLARE

ART. A010206S
LUCE LED PER MODULI

ART. A010207S
TRASFORMATORE



DESCRIZIONE: Luce led su profilo in alluminio angolare 120 LED/metro, luce a scelta Fredda/Naturale/Calda, assorbimento 9,6 Watt/metro. Complete di driver in potenza dedicato e cablaggio.

DESCRIPTION: Led light on angular aluminum profile 120 LED/meter, light options: Cold/Natural/Warm, power absorption 9,6 Watt/meter. Supplied with dedicated power driver and the concealed cable wiring.



ART. F53010186
MOBILE LIBRERIA DIRETTORIO

CUSTOMIZABLE

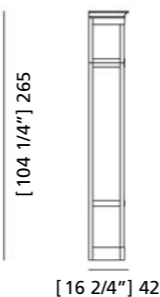
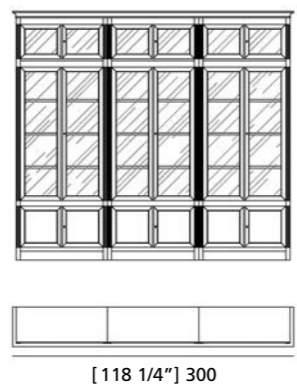

MISURE: L 300 P 42 H 265
DESCRIZIONE: proposta di Libreria Direttorio componibile in legno di ciliegio con 3 moduli ad anta in vetro centrale e antine in legno alla base; 3 sopralzi con ante a vetro. Ripiani regolabili su scaletta di legno. Finitura: F60. Design Centro Ricerche M.A.A.M.
PESO: 290 kg - m³: 3,9 - COLLI: 10

MEASURES: L 300 W 42 H 265
DESCRIPTION: proposal for Direttorio modular bookcase made of cherry wood. 3 central elements with glass and wooden hinged doors; 3 upper glass doors elements. Adjustable shelves on wooden support. Finishing: F60. Design Centro Ricerche M.A.A.M.
WEIGHT: 290 kg - m³: 3,9 - PIECES: 10

ART. F53010187
MOBILE LIBRERIA DIRETTORIO

CUSTOMIZABLE

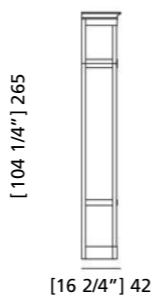
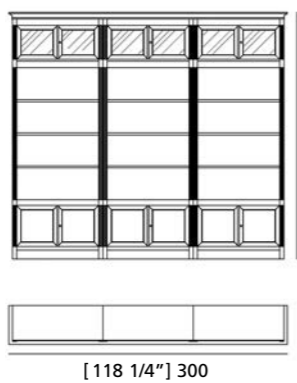

MISURE: L 300 P 42 H 265
DESCRIZIONE: Proposta di libreria Direttorio componibile in legno di ciliegio, formata da tre moduli con vano a giorno centrale e antine in legno alla base; tre sopralzi con ante a vetro. Ripiani interni regolabili su scaletta di legno. Finitura F32/C. Design Centro Ricerche M.A.A.M.
PESO: 260 kg - m³: 3,9 - COLLI: 10

MEASURES: L 300 W 42 H 265
DESCRIPTION: proposal for Direttorio modular bookcase made of cherry wood, central open element, lower wooden doors and upper glass doors. Finishing: F32. Design Centro Ricerche M.A.A.M.
WEIGHT: 260 kg - m³: 3,9 - PIECES: 10

ART. 3009
MOBILE LIBRERIA DIRETTORIO

CUSTOMIZABLE

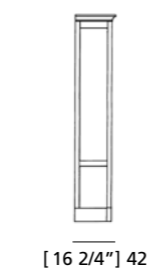
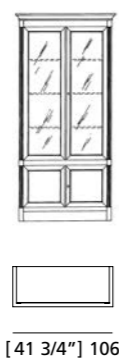

MISURE: L 106 P 42 H 220
DESCRIZIONE: modulo per Libreria Direttorio componibile in legno di ciliegio con due ante centrali in vetro e due antine in legno alla base, a battente. Ripiani regolabili su scaletta di legno. Su richiesta tutte le porte in legno o vetro. Finitura: F60. Design Centro Ricerche M.A.A.M.
MISURE SENZA CORNICIONE: L 97 P 38 H 214.
PESO: 73 kg - m³: 1,2 - COLLI: 2

MEASURES: L 106 W 42 H 220
DESCRIPTION: modular element for Direttorio bookcase made of cherry wood with two glass doors and two wooden doors at the base. Adjustable shelves on wooden support. Upon request all the doors in wood or glass. Finishing: F60. Design Centro Ricerche M.A.A.M.
SIZE WITHOUT TOP FRAME: L 97 W 38 H 214.
WEIGHT: 73 kg - m³: 1,2 - PIECES: 2

ART. 3010
MOBILE LIBRERIA DIRETTORIO

CUSTOMIZABLE

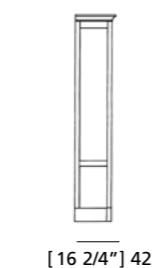

MISURE: L 106 P 42 H 220
DESCRIZIONE: modulo per Libreria Direttorio componibile in legno di ciliegio con comparto centrale a giorno e due antine in legno alla base, a battente. Ripiani regolabili su scaletta di legno. Su richiesta porte a vetro. Finitura: F60
MISURE SENZA CORNICIONE: L 97 P 38 H 214.
PESO: 60 kg - m³: 1,2 - COLLI: 2

MEASURES: L 106 W 42 H 220
DESCRIPTION: modular element for Direttorio bookcase made of cherry wood with central open compartment and two wooden doors at the base. Adjustable shelves on wooden support. Upon request glass doors. Finishing: F60
SIZE WITHOUT TOP FRAME: L 97 W 38 H 214.
WEIGHT: 60 kg - m³: 1,2 - PIECES: 2

ART. 3012
MOBILE LIBRERIA DIRETTORIO

CUSTOMIZABLE

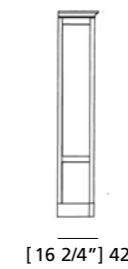
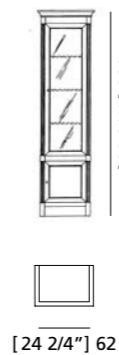

MISURE: L 62 P 42 H 220
DESCRIZIONE: Modulo per Libreria Direttorio componibile in legno di ciliegio con 1 anta centrale a vetro e 1 antina in legno alla base, a battente con apertura a destra. Ripiani regolabili su scaletta di legno. Su richiesta tutte le porte in legno o vetro. Finitura: F60
MISURE SENZA CORNICIONE: L 53 P 38 H 214
Disponibile con serratura apris/destro, vedi art. 3017
Design Centro Ricerche M.A.A.M.
PESO: 50 kg - m³: 0,65 - COLLI: 2

MEASURES: L 62 W 42 H 220
DESCRIPTION: Modular element for Direttorio bookcase made of cherry wood with 1 glass door and 1 wooden door at the base. Opening to the right. Adjustable shelves on wooden support. Upon request all the doors in wood or glass. Finishing: F60
Design Centro Ricerche M.A.A.M.
WEIGHT: 50 kg - m³: 0,65 - PIECES: 2

ART. 3017
MOBILE LIBRERIA DIRETTORIO

CUSTOMIZABLE

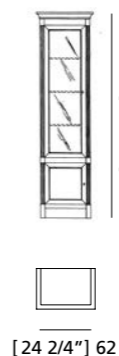

MISURE: L 62 P 42 H 220
DESCRIZIONE: modulo per Libreria Direttorio componibile in legno di ciliegio con 1 anta centrale a vetro e 1 antina in legno alla base, a battente con apertura a sinistra. Ripiani regolabili su scaletta di legno. Su richiesta tutte le porte in legno o vetro. Finitura: F60
MISURE SENZA CORNICIONE: L 53 P 38 H 214
Disponibile con serratura apris/destro, vedi art. 3012.
Design Centro Ricerche M.A.A.M.
PESO: 50 kg - m³: 0,65 - COLLI: 2

MEASURES: L 62 W 42 H 220
DESCRIPTION: modular element for Direttorio bookcase made of cherry wood with 1 glass door and 1 wooden door at the base. Opening to the left. Adjustable shelves on wooden support. Upon request all the doors in wood or glass. Finishing: F60
SIZE WITHOUT TOP FRAME: L 53 W 38 H 214
Available with opening to the right as art. 3012.
Design Centro Ricerche M.A.A.M.
WEIGHT: 50 kg - m³: 0,65 - PIECES: 2

ART. 3018
MOBILE LIBRERIA DIRETTORIO

CUSTOMIZABLE

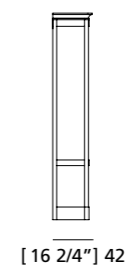
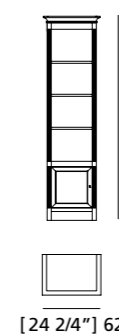

MISURE: L 62 P 42 H 220
DESCRIZIONE: modulo per Libreria Direttorio componibile in legno di ciliegio con comparto centrale a giorno e 1 antina in legno alla base, a battente con apertura a sinistra. Ripiani regolabili su scaletta di legno. Su richiesta porte a vetro. Finitura: F60.
MISURE SENZA CORNICIONE: L 53 P 38 H 214
Disponibile con serratura apris/destro, vedi art. 3011.
Design Centro Ricerche M.A.A.M.
PESO: 45 kg - m³: 0,65 - COLLI: 2

MEASURES: L 62 W 42 H 220
DESCRIPTION: modular element for Direttorio bookcase made of cherry wood with central open compartment and 1 wooden door at the base. Opening to the left. Adjustable shelves on wooden support. Upon request glass doors. Finishing: F60.
Design Centro Ricerche M.A.A.M.
WEIGHT: 45 kg - m³: 0,65 - PIECES: 2

ART. 3011
MOBILE LIBRERIA DIRETTORIO

CUSTOMIZABLE

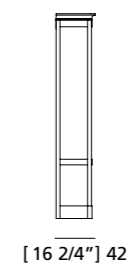
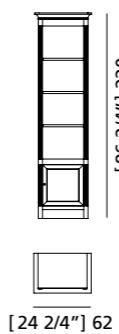

MISURE: L 62 P 42 H 220
DESCRIZIONE: modulo per Libreria Direttorio componibile in legno di ciliegio con comparto centrale a giorno e 1 antina in legno alla base, a battente con apertura a destra. Ripiani regolabili su scaletta di legno. Su richiesta porte a vetro. Finitura: F60
MISURE SENZA CORNICIONE: L 53 P 38 H 214
Disponibile con serratura apris/sinistra, vedi art. 3018. Design Centro Ricerche M.A.A.M.
PESO: 45 kg - m³: 0,65 - COLLI: 2

MEASURES: L 62 W 42 H 220
DESCRIPTION: Modular element for Direttorio bookcase made of cherry wood with central open compartment and 1 wooden door at the base. Right open. Adjustable shelves on wooden support. Upon request glass doors. Finishing: F60
SIZE WITHOUT TOP FRAME: L 53 W 38 H 214
Available with locking door opening to the left as art. 3018. Design Centro Ricerche M.A.A.M.
WEIGHT: 45 kg - m³: 0,65 - PIECES: 2

ART. 3019
MOBILE SOPRALZO DIRETTORIO

CUSTOMIZABLE

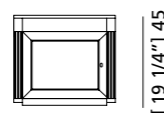

[19 1/4"] 45



[15"] 38

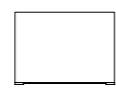

[20 3/4"] 53

MISURE: L 53 P 38 H 45
DESCRIZIONE: modulo sopralzo per Libreria Direttorio componibile in legno di ciliegio con 1 anta a battente in vetro. Finitura: F60
Design Centro Ricerche MAM
PESO: 15 kg - m³: 0,15 - COLLI: 1

MEASURES: L 53 W 38 H 45
DESCRIPTION: Modular upper element made of cherry wood with 1 hinged glass door. Upon request wooden door. Finishing: F60
Design Centro Ricerche MAM
WEIGHT: 15 kg - m³: 0,15 - PIECES: 1

ART. 3015
MOBILE SOPRALZO DIRETTORIO

CUSTOMIZABLE

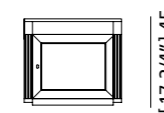

[17 2/4"] 45



[15"] 38

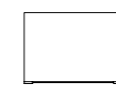

[20 3/4"] 53

MISURE: L 53 P 38 H 45
DESCRIZIONE: modulo sopralzo per Libreria Direttorio componibile in legno di ciliegio con 1 anta a battente in vetro. Su richiesta porta in legno. Finitura: F60
Design Centro Ricerche MAM
PESO: 15 kg - m³: 0,15 - COLLI: 1

MEASURES: L 53 W 38 H 45
DESCRIPTION: modular upper element made of cherry wood with 1 hinged glass door. Upon request wooden door. Finishing: F60
Design Centro Ricerche MAM
WEIGHT: 15 kg - m³: 0,15 - PIECES: 1

ART. 3013
MOBILE SOPRALZO DIRETTORIO

CUSTOMIZABLE

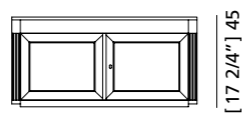

[17 2/4"] 45



[15"] 38

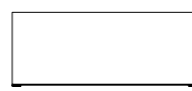

[38 1/4"] 97

MISURE: L 97 P 38 H 45
DESCRIZIONE: modulo sopralzo per Libreria Direttorio componibile in legno di ciliegio con 2 ante a battente in vetro. Su richiesta porta in legno. Finitura: F100
Design Centro Ricerche MAM
PESO: 20 kg - m³: 0,21
COLLI: 1

MEASURES: L 97 W 38 H 45
DESCRIPTION: modular upper element made of cherry wood with hinged glass doors. Upon request wooden doors. Finishing: F60
Design Centro Ricerche MAM
WEIGHT: 20 kg - m³: 0,21
PIECES: 1

ART. 3029
CORNICE AL METRO LINEARE



[2 2/4"] 6

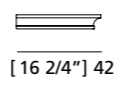

[16 2/4"] 42



[41 3/4"] 106

MISURE: L 106 P 42 H 6
DESCRIZIONE: cornice a misura da sovrapporre alle composizioni Direttorio. PESO: 4 kg/m - m³: 0,05
COLLI: 1

MEASURES: L 106 P 42 H 6
DESCRIPTION: frame made to measure to complete Direttorio compositions. WEIGHT: 4 kg/m - m³: 0,05
PIECES: 1

ART. 3345
ELEMENTO SCALA

ART. A0101805
BARRA TUBOLARE AL M.T.L.



[13 3/4"] 35

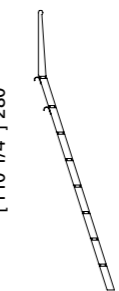

[110 1/4"] 280

[2 2/4"] 7

MISURE: L 35 P 7 H 280
DESCRIZIONE: elemento scala per composizioni a doppia altezza. PESO: 8 kg - m³: 0,02
COLLI: 1

MEASURES: L 35 P 7 H 280
DESCRIPTION: ladder for compositions with double height. WEIGHT: 8 kg - m³: 0,02
PIECES: 1



ART. FS3012339
MOBILE LIBRERIA PRESIDENT

CUSTOMIZABLE

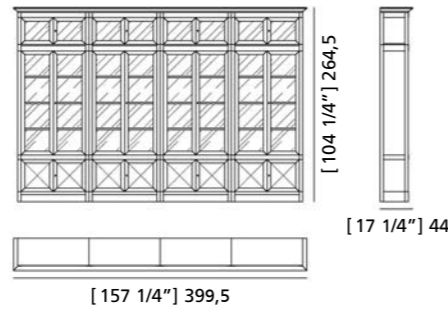

MISURE: L 399,5 P 44 H 264,5
DESCRIZIONE: proposta di Libreria President componibile in legno di ciliegio con 4 moduli costituiti da sopralzi, ante centrali in vetro con ripiani interni regolabili e nella sezione inferiore da antine a battente decorate.
Design Centro Ricerche MAM
PESO: 392 kg - m³: 5 - COLLI: 13

MEASURES: L 399,5 P 44 H 264,5
DESCRIPTION: proposal for President modular bookcase made of cherry wood with four units with top elements, central glass doors and adjustable shelves and in the lower section decorated wooden doors.
Design Centro Ricerche MAM
WEIGHT: 392 kg - m³: 5 - PIECES: 13

ART. 3106
CORNICE AL METRO LINEARE

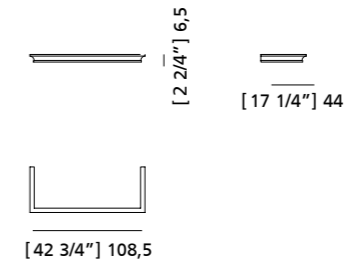

MISURE: L 108,5 P 44 H 6,5
DESCRIZIONE: Cornice in legno di ciliegio.
Design Centro Ricerche MAM

MEASURES: L 108,5 P 44 H 6,5
DESCRIPTION: Wooden frame for president modular elements.
Design Centro Ricerche MAM

ART. 3103
MODULO LIBRERIA PRESIDENT

CUSTOMIZABLE

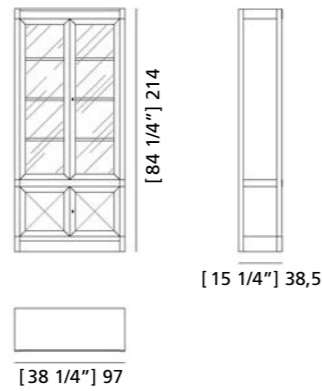

MISURE: L 97 P 38,5 H 214
DESCRIZIONE: Modulo in legno di ciliegio, due ante a vetro e due ante a legno con pregiata impiallacciatura, ripiani interni regolabili.
Design Centro Ricerche MAM
PESO: 73 kg - m³: 0,8 - COLLI: 2

MEASURES: L 97 P 38,5 H 214
DESCRIPTION: President modular open element with lower wooden doors.
Design Centro Ricerche MAM
WEIGHT: 73 kg - m³: 0,8 - PIECES: 2

ART. 3104
MOBILE LIBRERIA PRESIDENT

CUSTOMIZABLE

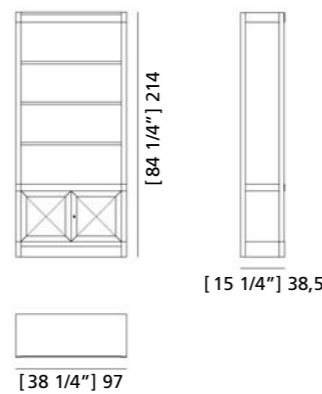

MISURE: L 97 P 38,5 H 214
DESCRIZIONE: Modulo in legno di ciliegio, vano a giorno e due ante a legno con pregiata impiallacciatura, ripiani interni regolabili.
Design Centro Ricerche MAM
PESO: 60 kg - m³: 0,8 - COLLI: 2

MEASURES: L 97 P 38,5 H 214
DESCRIPTION: President modular open element with loower wooden doors.
Design Centro Ricerche MAM
WEIGHT: 60 kg - m³: 0,8 - PIECES: 2

ART. 3105
MOBILE LIBRERIA PRESIDENT

CUSTOMIZABLE

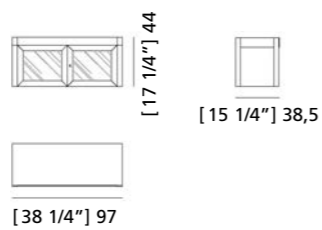

MISURE: L 97 P 38,5 H 44
DESCRIZIONE: Sopralzo in legno di ciliegio, due ante a vetro.
Design Centro Ricerche MAM
PESO: 20 kg - m³: 0,15 - COLLI: 1

MEASURES: L 97 P 38,5 H 44
DESCRIPTION: President modular upper element with glass doors.
Design Centro Ricerche MAM
WEIGHT: 20 kg - m³: 0,15 - PIECES: 1

LIBRERIE

BOOKCASES



ART. 6205/F
LIBRERIA SWING

CUSTOMIZABLE

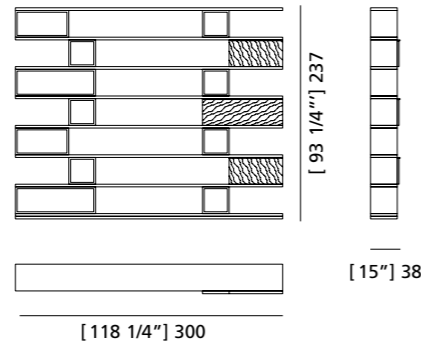
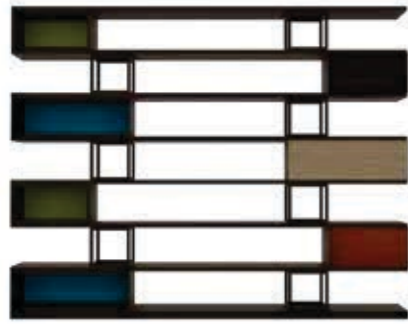

MISURE: L 300 P 38 H 237
DESCRIZIONE: Libreria scaffalatura con moduli chiusi da anta a battente, moduli a giorno e moduli in ferro. Finitura F32/F. Design Libero Rutilo
PESO: 120 kg. - m³: 1,3 COLLI: 2

MEASURES: L 300 P 38 H 237
DESCRIPTION: Bookcase made of ash wood with doors and open elements. Design: Libero Rutilo
WEIGHT: 120 kg - m³: 1,3 - PIECES: 2

ART. 6206/F
LIBRERIA SWING

CUSTOMIZABLE

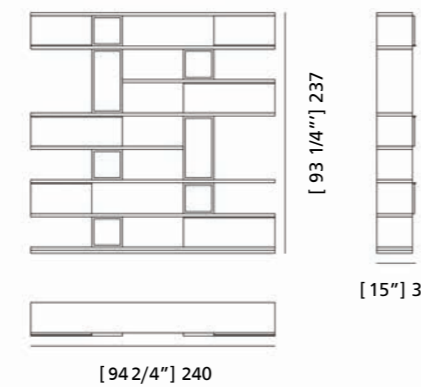

MISURE: L 240 P 38 H 237
DESCRIZIONE: Libreria a ripiani in legno di frassino con moduli chiusi con anta a vasistas, moduli a giorno e moduli in ferro. Design: Libero Rutilo
PESO: 110 kg. - m³: 1,3 COLLI: 4

MEASURES: L 240 P 38 H 237
DESCRIPTION: Bookshelf in ash wood with door-elements, open elements and metal spacer cubes. Design: Libero Rutilo
WEIGHT: 110 kg - m³: 1,3 PIECES: 4

ART. 6204/F
LIBRERIA PERBACCO

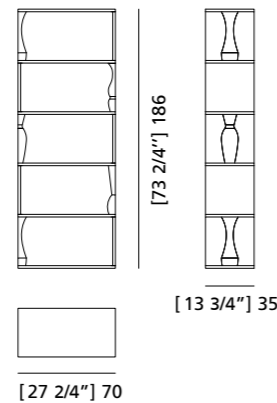

MISURE: L 70 P 35 H 186
DESCRIZIONE: Libreria in legno di frassino con fianchi a colonne tornite. Design: Itamar Harari
PESO: 50 kg. - m³: 0,55 COLLI: 1

MEASURES: L 70 P 35 H 186
DESCRIPTION: Bookcase made of ash wood with turned columns. Design: Itamar Harari
WEIGHT: 50 kg - m³: 0,55 PIECES: 1

FS6214571
LIBRERIA PERBACCO

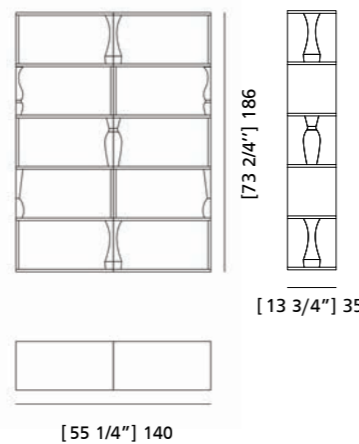

MISURE: L 140 P 35 H 186
DESCRIZIONE: Libreria a due moduli in legno di frassino con fianchi a colonne tornite. Design: Itamar Harari
PESO: 100 kg. - m³: 0,9 COLLI: 2

MEASURES: L 140 P 35 H 186
DESCRIPTION: Two-module bookcase in ash wood with turned columns. Design: Itamar Harari
WEIGHT: 100 kg - m³: 0,9 PIECES: 2

ART. 6201/F
LIBRERIA BELLAGIO

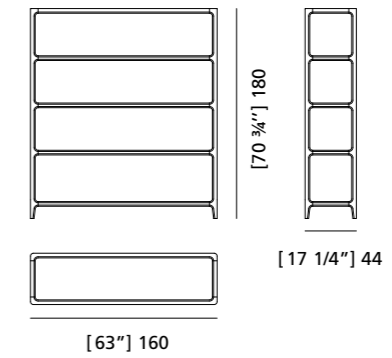

MISURE: L 160 P 44 H 180
DESCRIZIONE: Libreria in legno di frassino con ripiani in vetro o pietra. Design: Libero Rutilo
PESO: 120 kg. - m³: 1,3 COLLI: 2

MEASURES: L 160 P 44 H 180
DESCRIPTION: Bookcase made of ash wood with glass shelves. Design: Libero Rutilo
WEIGHT: 120 kg - m³: 1,3 PIECES: 2

ART. 6299/F
LIBRERIA SUPERGIÙ

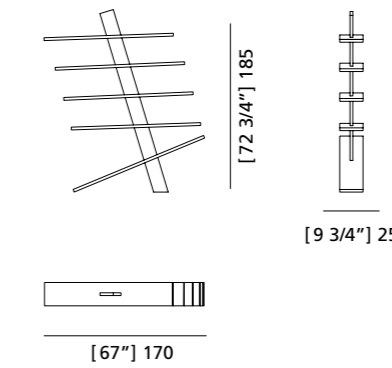

MISURE: L 170 P 25 H 185
DESCRIZIONE: libreria autoportante in legno massello di frassino composta da un elemento portante verticale e 4 ripiani in legno con incastonatura diagonale. Predisposizione fori per fissaggio a muro. Finitura: F32. Design Marco Ferreri.
PESO: 45 kg - m³: 1 - COLLI: 1

MEASURES: L 170 W 25 H 185
DESCRIPTION: freestanding bookcase made of solid ash, consists of a vertical supporting element and 4 diagonally joined shelves. Equipped with holes for wall mounting. Finishing: F32 Design by Marco Ferreri.
WEIGHT: 45 kg - m³: 1 - PIECES: 1

ART. 3620
LIBRERIA KANT NOCE O FRASSINO

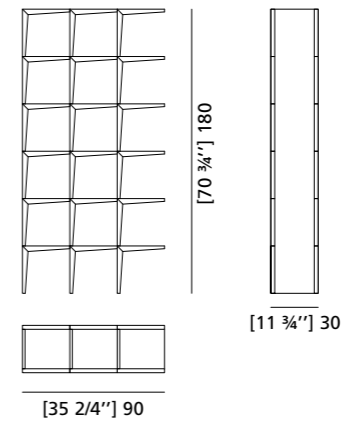

MISURE: L 90 P 30 H 180
DESCRIZIONE: libreria bifacciale a giorno realizzata in legno di frassino. Una sezione del lato rimane "aperta" consentendo di affiancare più moduli, per una personalizzazione su misura. Design: Itamar Harari
PESO: 33 kg - m³: 0,50 - COLLI: 1

MEASURES: L 90 W 30 H 180
DESCRIPTION: double-sided open bookcase made of ash wood. The particular shape with one open side offers the possibility to combine several units, thus allowing the creation of a tailor-made bookcase. Design: Itamar Harari
WEIGHT: 33 kg - m³: 0,50 - PIECES: 1

ART. 6292
LIBRERIA BABILONIA

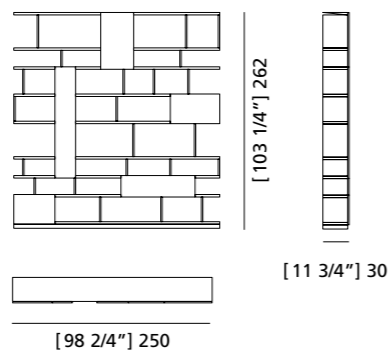

MISURE: L 250 P 30 H 262
DESCRIZIONE: libreria bifacciale componibile con ripiani fissi in legno di wengè e tramezze in frassino. 5 vani contenitori con ante impiallacciate in Ebanò Makassar, Padouk, Acero, Noce e Ciliegio. Finitura: F32. Design: Maurizio Duranti
PESO: 216 kg - m³: 2,70 **COLLI:** 2

MEASURES: L 250 W 30 H 262
DESCRIPTION: double face bookcase with fixed shelves made of wengè wood. 5 container elements with veneered doors in essences of Makassar Ebony, Walnut, Maple, Cherry and Padouk. Finishing: F32. DESIGN: Maurizio Duranti
WEIGHT: 216 kg - m³: 2,70 **PIECES:** 2

ART. 6202/F
LIBRERIA ERRANTE

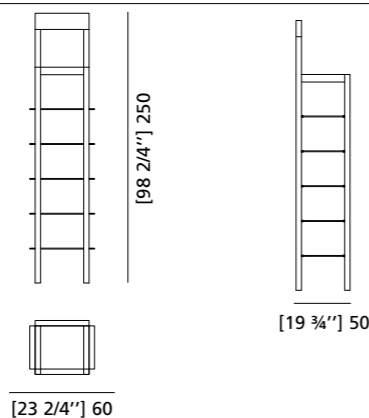

MISURE: L 60 P 50 H 250
DESCRIZIONE: libreria a forma di sedia in legno di frassino con 5 ripiani in cristallo. Opera installata presso Palazzo Bembo durante la 55ª Biennale D'Arte di Venezia - 2013 Design: Michele Manzini.
PESO: 68 kg - m³: 0,85 - **COLLI:** 2

MEASURES: L 60 W 50 H 250
DESCRIPTION: bookcase in a chair shape made of ash wood with 5 glass shelves. Piece exhibited at Palazzo Bembo at the 55th Biennale Art Exhibition in Venice -2013 edition
 Design: Michele Manzini.
WEIGHT: 68 kg - m³: 0,85 - **PIECES:** 2

ART. 6298
LIBRERIA BERENICE

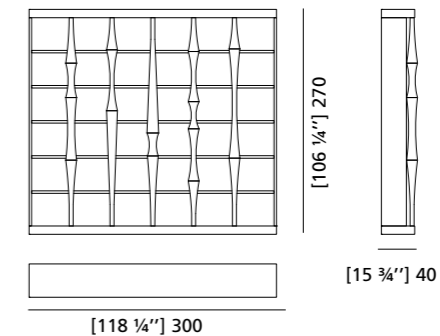

MISURE: L 300 P 40 H 270
DESCRIZIONE: libreria con ripiani a giorno in legno di ciliegio laccato blu notte e "lance" in legno di acero; base e top in acero. Edizione 2010. Design: Luca Scacchetti
PESO: 250 kg. - m³: 2 - **COLLI:** 17

MEASURES: L 300 W 40 H 270
DESCRIPTION: open bookcase made of dark blue finished cherry wood and maple columns, base and top made of maple wood. Edition 2010
 Design: Luca Scacchetti
WEIGHT: 250 kg - m³: 2 - **PIECES:** 17

ART. 3401
LIBRERIA CARTESIA

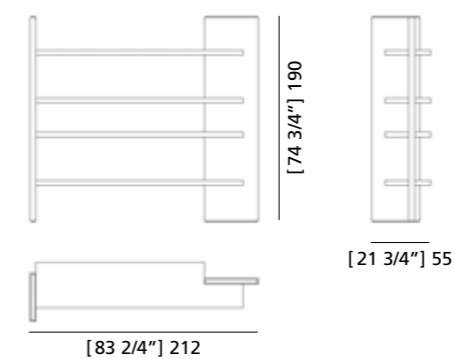

MISURE: L 212 P 55 H 190
DESCRIZIONE: libreria bifacciale autoportante composta da 2 elementi portanti verticali in noce canaletto e 4 ripiani in acero spessore 4,5 cm.
MISURE RIPIANI: L 156,6 P 42,5 H 4,5 Finitura: F32. Design Franco Poli.
PESO: 74 kg - m³: 0,40 **COLLI:** 3

MEASURES: L 212 W 55 H 190
DESCRIPTION: freestanding bookcase with 2 double face vertical elements and 4 shelves in walnut and maple, thickness of 4.5 cm.
MEASURES OF SHELVES: L156.6 W42.5 H4.5. Finishing: F32. Design By Franco Poli.
WEIGHT: 74 kg - m³: 0,40 **PIECES:** 3

CREDENZE

CABINETS



ART. 1738/F
CREDENZA JOYCE

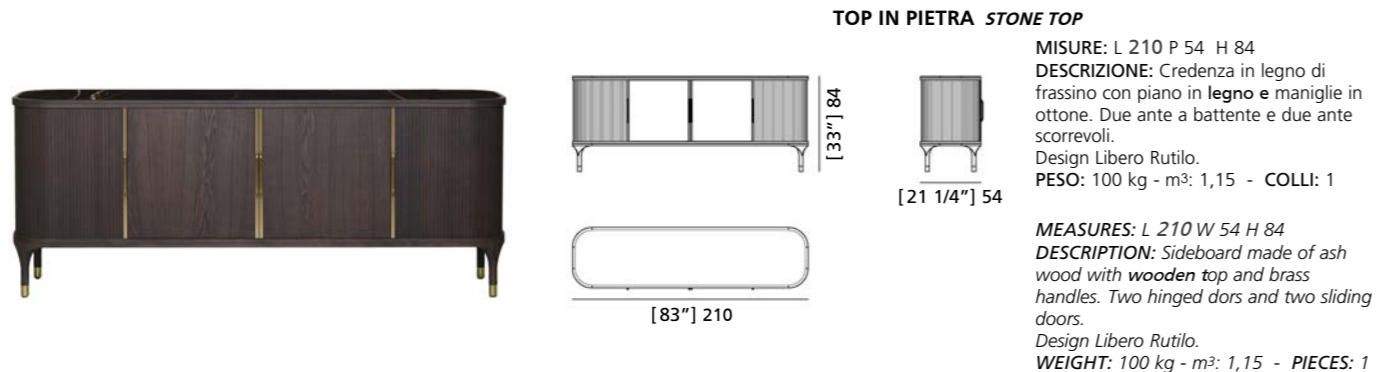

TOP IN PIETRA STONE TOP

MISURE: L 210 P 54 H 84
DESCRIZIONE: Credenza in legno di frassino con piano in legno e maniglie in ottone. Due ante a battente e due ante scorrevoli.
Design Libero Rutilo.
PESO: 100 kg - m³: 1,15 - COLLI: 1

MEASURES: L 210 W 54 H 84
DESCRIPTION: Sideboard made of ash wood with wooden top and brass handles. Two hinged doors and two sliding doors.
Design Libero Rutilo.
WEIGHT: 100 kg - m³: 1,15 - PIECES: 1

ART. 1739/F
CREDENZA JOYCE

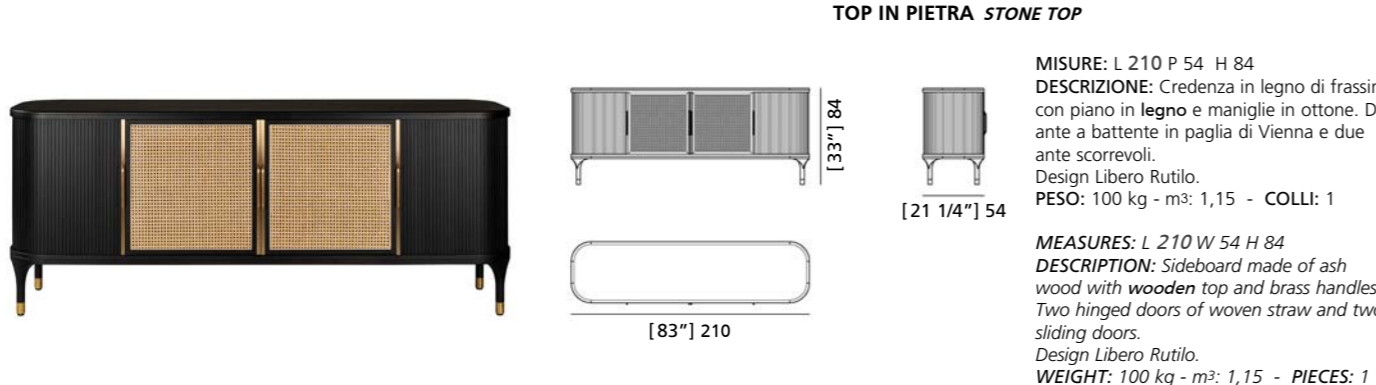

TOP IN PIETRA STONE TOP

MISURE: L 210 P 54 H 84
DESCRIZIONE: Credenza in legno di frassino con piano in legno e maniglie in ottone. Due ante a battente in paglia di Vienna e due ante scorrevoli.
Design Libero Rutilo.
PESO: 100 kg - m³: 1,15 - COLLI: 1

MEASURES: L 210 W 54 H 84
DESCRIPTION: Sideboard made of ash wood with wooden top and brass handles. Two hinged doors of woven straw and two sliding doors.
Design Libero Rutilo.
WEIGHT: 100 kg - m³: 1,15 - PIECES: 1

ART. 1715
MOBILE BAR VERONESE

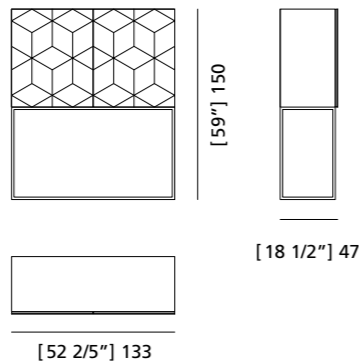

MISURE: L 133 W 47 H 150
DESCRIZIONE: Mobile bar a due ante con struttura in ferro e scocca in legno di frassino, ante in Ebano, Ciliegio e Acero.
Design Centro Ricerche MAMM
PESO: 90 kg - m³: 1,05
COLLI: 1

MEASURES: L 133 W 47 H 150
DESCRIPTION: Bar cabinet with two doors and iron base, structure made of ash wood and doors veneered with maple, cherry ebony.
Design by Centro Ricerche MAMM
WEIGHT: 90 kg - m³: 1,05
PIECES: 1

ART. 1741/F
CREDENZA BELLAGIO

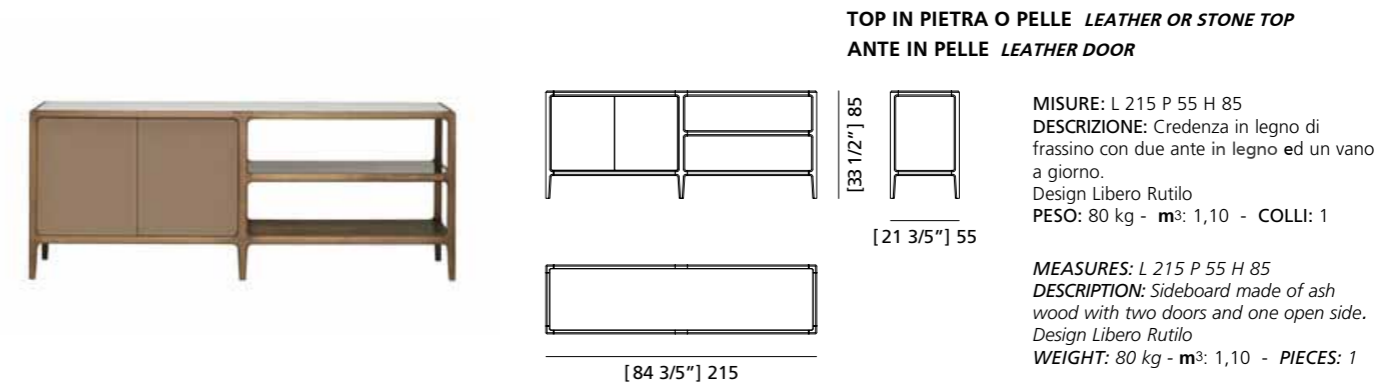

TOP IN PIETRA O PELLE LEATHER OR STONE TOP
ANTE IN PELLE LEATHER DOOR

MISURE: L 215 P 55 H 85
DESCRIZIONE: Credenza in legno di frassino con due ante in legno ed un vano a giorno.
Design Libero Rutilo
PESO: 80 kg - m³: 1,10 - COLLI: 1

MEASURES: L 215 P 55 H 85
DESCRIPTION: Sideboard made of ash wood with two doors and one open side.
Design Libero Rutilo
WEIGHT: 80 kg - m³: 1,10 - PIECES: 1

ART. 1733/F
CREDENZA SWING

CUSTOMIZABLE

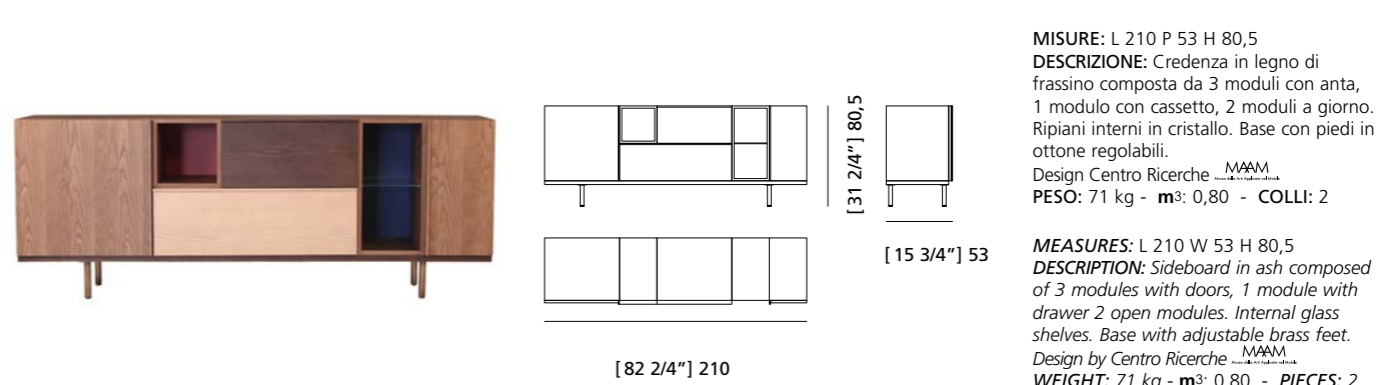

MISURE: L 210 P 53 H 80,5
DESCRIZIONE: Credenza in legno di frassino composta da 3 moduli con anta, 1 modulo con cassetto, 2 moduli a giorno. Ripiani interni in cristallo. Base con piedi in ottone regolabili.
Design Centro Ricerche MAMM
PESO: 71 kg - m³: 0,80 - COLLI: 2

MEASURES: L 210 W 53 H 80,5
DESCRIPTION: Sideboard in ash composed of 3 modules with doors, 1 module with drawer 2 open modules. Internal glass shelves. Base with adjustable brass feet.
Design by Centro Ricerche MAMM
WEIGHT: 71 kg - m³: 0,80 - PIECES: 2

ART. 1734/F
CREDENZA SWING

CUSTOMIZABLE

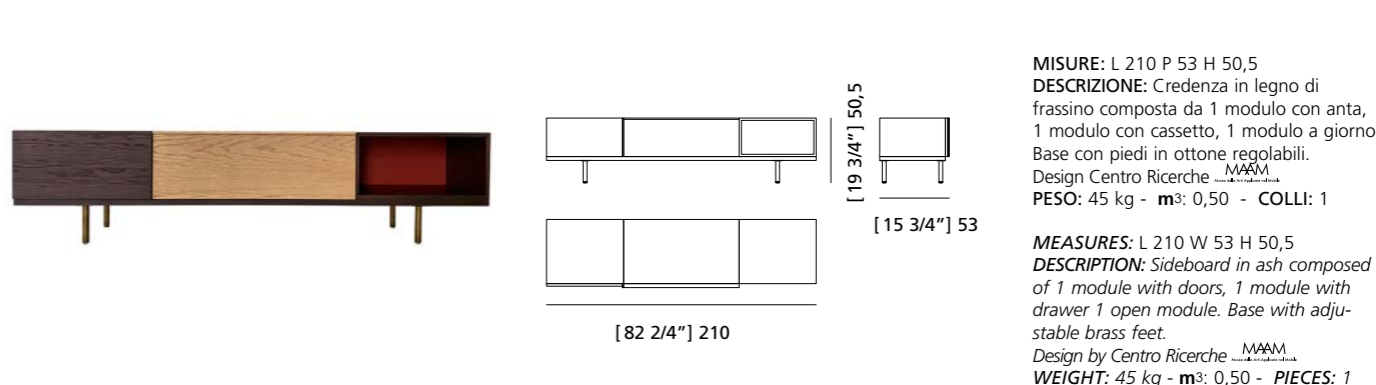

MISURE: L 210 P 53 H 50,5
DESCRIZIONE: Credenza in legno di frassino composta da 1 modulo con anta, 1 modulo con cassetto, 1 modulo a giorno. Base con piedi in ottone regolabili.
Design Centro Ricerche MAMM
PESO: 45 kg - m³: 0,50 - COLLI: 1

MEASURES: L 210 W 53 H 50,5
DESCRIPTION: Sideboard in ash composed of 1 module with doors, 1 module with drawer 1 open module. Base with adjustable brass feet.
Design by Centro Ricerche MAMM
WEIGHT: 45 kg - m³: 0,50 - PIECES: 1

ART. 1735/F
CREDENZA SWING

CUSTOMIZABLE

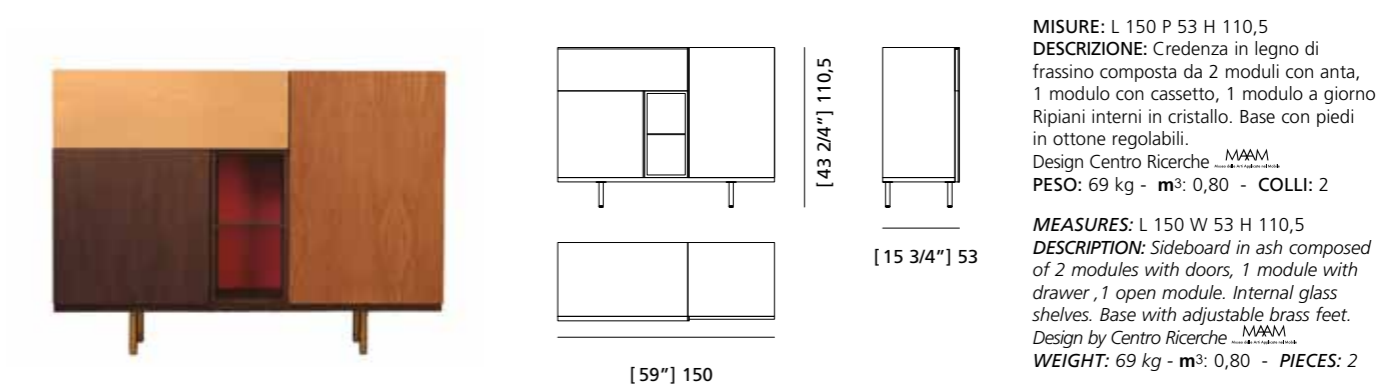

MISURE: L 150 P 53 H 110,5
DESCRIZIONE: Credenza in legno di frassino composta da 2 moduli con anta, 1 modulo con cassetto, 1 modulo a giorno. Ripiani interni in cristallo. Base con piedi in ottone regolabili.
Design Centro Ricerche MAMM
PESO: 69 kg - m³: 0,80 - COLLI: 2

MEASURES: L 150 W 53 H 110,5
DESCRIPTION: Sideboard in ash composed of 2 modules with doors, 1 module with drawer, 1 open module. Internal glass shelves. Base with adjustable brass feet.
Design by Centro Ricerche MAMM
WEIGHT: 69 kg - m³: 0,80 - PIECES: 2

ART. 1742/F
CREDENZA SWING

CUSTOMIZABLE

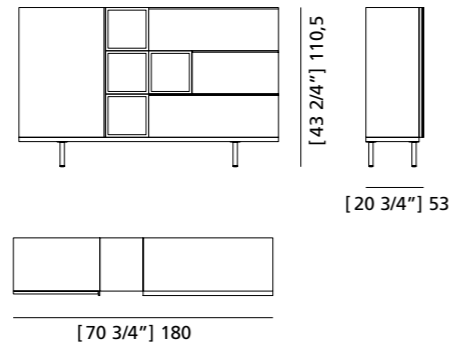

MISURE: L 180 P 53 H 110,5
DESCRIZIONE: Credenza in legno di frassino composta da moduli a giorno, moduli con ante e moduli con cassetto, ripiani interni in cristallo, base con piedi in ottone regolabili.
PESO: 80 kg - m³: 1,05 - COLLI: 1

MEASURES: L 180 P 53 H 110,5
DESCRIPTION: Sideboard in ash wood with doors, drawers and open elements internal glass shelves.
Base with adjustable brass feet.
WEIGHT: 80 kg - m³: 1,05 - PIECES: 1

ART. 1743/F
CREDENZA SWING

CUSTOMIZABLE

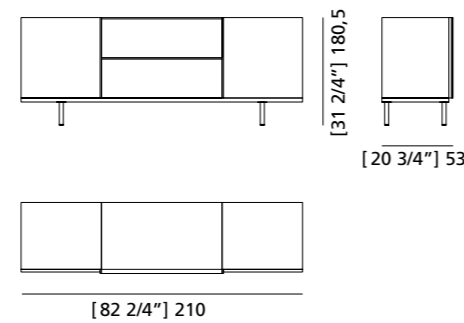

MISURE: L 210 P 53 H 80,5
DESCRIZIONE: Credenza in legno di frassino composta da moduli con ante e moduli con cassetto, ripiani interni in cristallo, base con piedi in ottone regolabili.
PESO: 70 kg - m³: 0,90 - COLLI: 1

MEASURES: L 210 P 53 H 80,5
DESCRIPTION: Sideboard in ash wood with doors and drawers.
Base with adjustable brass feet.
WEIGHT: 70 kg - m³: 0,90 - PIECES: 1

ART. 1744/F
CREDENZA SWING

CUSTOMIZABLE

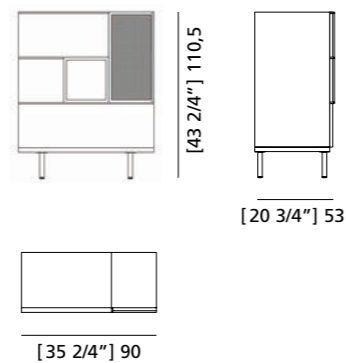

MISURE: L 90 P 53 H 110,5
DESCRIZIONE: Credenza in legno di frassino composta da moduli con ante, moduli a giorno e moduli con cassetto, ripiani interni in cristallo, base con piedi in ottone regolabili.
PESO: 45 kg - m³: 0,50 - COLLI: 1

MEASURES: L 90 P 53 H 110,5
DESCRIPTION: Sideboard in ash wood with doors, drawers and open element.
Base with adjustable brass feet.
WEIGHT: 45 kg - m³: 0,50 - PIECES: 1

ART. 5801/F
CONSOLLE SWING

CUSTOMIZABLE

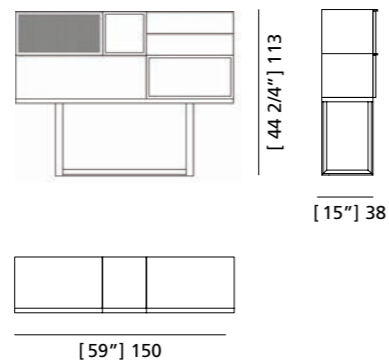

MISURE: L 150 P 38 H 113
DESCRIZIONE: Consolle in legno di frassino composta da moduli con cassetto e moduli a giorno, base con struttura in legno.
PESO: 40 kg - m³: 0,65 - COLLI: 1

MEASURES: L 150 P 38 H 113
DESCRIPTION: Consolle in ash wood with doors, drawers and open element.
WEIGHT: 40 kg - m³: 0,65 - PIECES: 1

ART. 1709
CREDENZA VERONESE

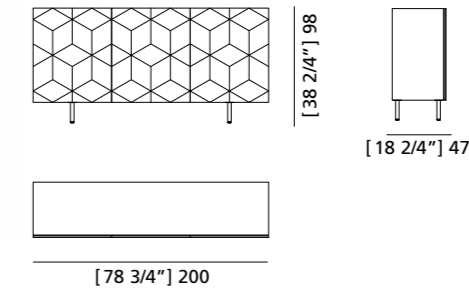

MISURE: L 200 P 47 H 98
DESCRIZIONE: Credenza in legno di frassino con ante in acero, ciliegio ed ebano. L'intarsio a cubi prospettici è un'arte sviluppata a Verona fin dal 1400. Interni colorati con 3 cassetti centrali. Piedi in ottone. Design: Centro Ricerche MAMM.

MEASURES: L 200 W 47 H 98
DESCRIPTION: sideboard made of ash wood and doors with maple, cherry and ebony. Cubic prospective inlay is a craft firstly developed in Verona since XV century. Colored interior with 3 central drawers. Brass feet.
Design: Centro Ricerche MAMM.
WEIGHT: 90 kg - m³: 1 - PIECES: 1

ART. 1703
CREDENZA FANTESCA

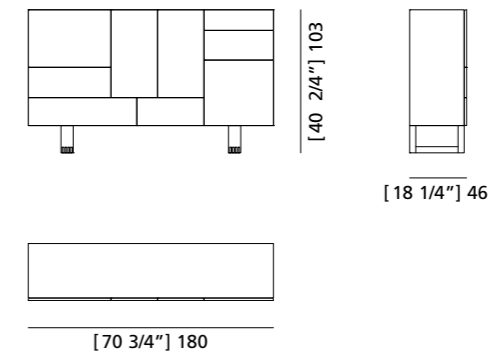

MISURE: L 180 P 46 H 103
DESCRIZIONE: credenza con struttura in legno di frassino. 4 ante e 2 cassetti impiallacciati con essenze di Ebano Makassar, Noce, Acero, Ciliegio e Padouk. Design Maurizio Duranti.

PESO: 90 kg - m³: 0,9 - COLLI: 1
MEASURES: L 180 W 46 H 103
DESCRIPTION: sideboard made of ash wood. 4 doors and 2 drawers veneered with Makassar Ebony, Walnut, Maple, Cherry and Padouk.
Design Maurizio Duranti.
WEIGHT: 90 kg - m³: 0,9 - PIECES: 1

ART. 1721
CREDENZA BIG JOHN

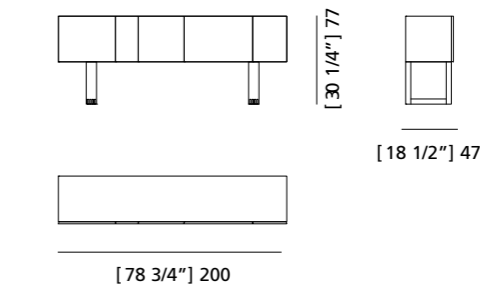

MISURE: L 200 P 47 H 77
DESCRIZIONE: Credenza con struttura in legno di frassino. Cassetti e ante impiallacciati con essenze di Ebano Makassar, Noce, Acero, Ciliegio e Padouk. Design Maurizio Duranti.

PESO: 50 kg - m³: 0,75
COLLI: 1
MEASURES: L 200 W 47 H 77
DESCRIPTION: Sideboard with frame made of ash wood. Drawers and doors veneered with different wood types: ebony Makassar, walnut, maple, cherry, padouk.
Design Maurizio Duranti.
WEIGHT: 50 kg - m³: 0,75
PIECES: 1

ART. 1763
CREDENZA LOCANDIERA

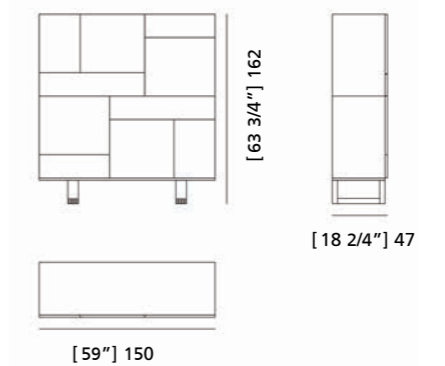

MISURE: L 150 P 47 H 162
DESCRIZIONE: Credenza con struttura in legno di frassino. 2 Cassetti e 6 ante impiallacciati con essenze di Ebano Makassar, Noce, Acero, Ciliegio e Padouk. Design Maurizio Duranti.

PESO: 110 kg - m³: 1,15
COLLI: 1
MEASURES: L 150 W 47 H 162
DESCRIPTION: Sideboard with frame made of ash wood. 2 Drawers and 6 doors veneered with different wood types: ebony Makassar, walnut, maple, cherry, padouk.
Design Maurizio Duranti.
WEIGHT: 110 kg - m³: 1,15
PIECES: 1

ART. 1708
CREDENZA SHERWOOD

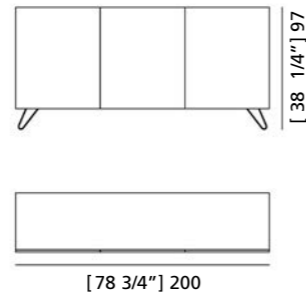

[38 1/4"] 97

[18 2/4"] 47

[78 3/4"] 200

MISURE: L 200 P 47 H 97
DESCRIZIONE: credenza in legno di frassino a 3 ante con pregiata impiallacciatura di noce nazionale. Interno colorato con ripiani regolabili e cassetiera nel vano centrale. Piedini in acciaio. Finitura: F32/A, interno colorato.
 Design: Maurizio Duranti
PESO: 90 kg - m³: 1 - **COLLI:** 1
MEASURES: L 200 W 47 H 97
DESCRIPTION: sideboard made of ash wood, 3 doors finely veneered with walnut. Colorful interior with adjustable shelves and 3 drawers in the central compartment. Steel feet. Finishing: F32/A, colorful interior.
 Designer: Maurizio Duranti
WEIGHT: 90 kg - m³: 1 - **PIECES:** 1

ART. 1705/F
CREDENZA MALIBÙ

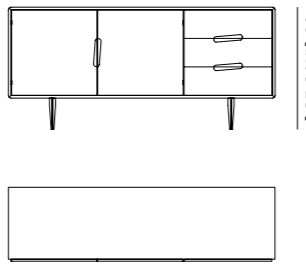

[35 2/4"] 90

[21 2/4"] 55

[76 1/4"] 193,5

MISURE: L 193,5 P 55 H 90
DESCRIZIONE: credenza in frassino con 2 ante, 1 ripiano interno regolabile e 3 cassetti con guide metalliche. Particolare maniglia intarsiata in diagonale. Base struttura con gambe in legno a sezione triangolare. Finitura: F32/N.
 Design Centro Ricerche MAMM
Peso: 80 kg - m³: 0,95 - **COLLI:** 1
MEASURES: L 193,5 W 55 H 90
DESCRIPTION: Made of ash wood sideboard with 2 doors, 1 adjustable shelf and 3 drawers with metal runners. Particular diagonally handles. Base frame with wooden legs with a triangular section. Finishing: F32/N.
 Design by Centro Ricerche MAMM
WEIGHT: 80 kg - m³: 0,95 - **PIECES:** 1

ART. 1707
CREDENZA SIPARIO

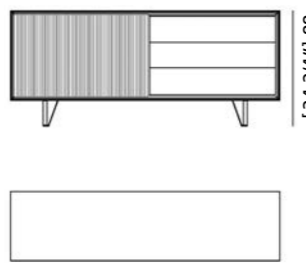

[34 2/4"] 88

[20 3/4"] 53

[81"] 206

MISURE: L 206 P 53 H 88
DESCRIZIONE: credenza con struttura in legno di ciliegio, 1 anta scorrevole modello Code con 2 ripiani interni regolabili e 3 cassetti push&pull con frontale in noce canaletto. Finiture: F32.
 Design Centro Ricerche MAMM
PESO: 100 kg - m³: 1,2 - **COLLI:** 1
MEASURES: L 206 W 53 H 88
DESCRIPTION: sideboard made of cherry wood with 1 "Code" sliding door, 2 internal adjustable shelves and 3 drawers with push & pull mechanism and Canaletto walnut front. Finishing: F32.
 Design by Centro Ricerche MAMM
WEIGHT: 100 kg - m³: 1,2 - **PIECES:** 1

ART. 1789
CREDENZA OBLO'

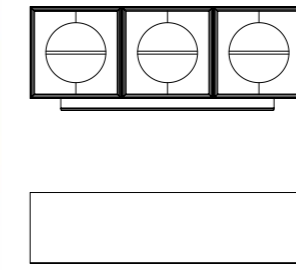

[30 3/4"] 78

[20 3/4"] 53

[81"] 206

MISURE: L 206 P 53 H 78
DESCRIZIONE: Credenza in legno di ciliegio con tre ante oblo' in acero e noce art. 3456. Ripiani interni regolabili. Finitura F32.
 Design: Centro Ricerche MAMM
Peso: 85 kg - m³: 1,00 - **COLLI:** 1
MEASURES: L 206 P 53 H 78
DESCRIPTION: Credenza in legno di ciliegio con tre ante oblo' in acero e noce art. 3456. Ripiani interni regolabili. Finitura F32.
 Design: Centro Ricerche MAMM
WEIGHT: 85 kg - m³: 1,00 - **PIECES:** 1

ART. 1722
CREDENZA ZERO

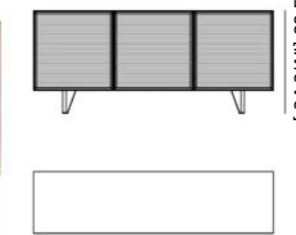

[34 3/4"] 88,5

[20 3/4"] 53

[81"] 206

MISURE: L 206 P 53 H 88,5
DESCRIZIONE: credenza in legno di ciliegio. Ripiani interni regolabili. Disponibile con ante, piedini e accessori della collezione Zero. Design Centro Ricerche MAMM
PESO: 90 kg - m³: 1 - **COLLI:** 1
MEASURES: L 206 W 53 H 88,5
DESCRIPTION: sideboard made of cherry wood. Adjustable shelves. Available with doors, drawers and accessories of the Zero collection.
 Design Centro Ricerche MAMM
WEIGHT: 90 kg - m³: 1 - **PIECES:** 1

ART. 1796
CREDENZA ZERO

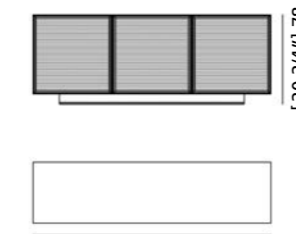

[30 3/4"] 78

[20 3/4"] 53

[81"] 206

MISURE: L 206 P 53 H 78
DESCRIZIONE: Credenza a tre vani in legno di ciliegio della collezione Zero. Ripiani interni regolabili. Disponibile con ante, cassetti e accessori della collezione Zero. Design Centro Ricerche MAMM
PESO: 89 kg - m³: 1 - **COLLI:** 1
MEASURES: L 206 W 53 H 78
DESCRIPTION: Sideboard made with a three-rooms Zero structure. Adjustable shelves. Available with doors, drawers and accessories of the Zero collection.
 Design by Centro Ricerche MAMM
WEIGHT: 89 kg - m³: 1 - **PIECES:** 1

ART. 1781
CREDENZA ZERO

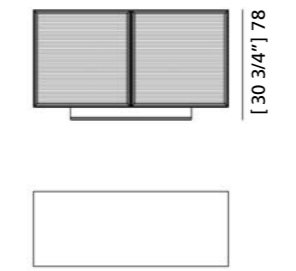

[30 3/4"] 78

[20 3/4"] 53

[54"] 137

MISURE: L 137 P 53 H 78
DESCRIZIONE: Credenza a due vani in legno di ciliegio della collezione Zero. Ripiani interni regolabili. Disponibile con ante, cassetti e accessori della collezione Zero. Design Centro Ricerche MAMM
PESO: 66 kg - m³: 0,63 - **COLLI:** 1
MEASURES: L 137 W 53 H 78
DESCRIPTION: Sideboard made with a two-compartment Zero structure. Adjustable shelves. Available with doors, drawers and accessories of the Zero collection.
 Design by Centro Ricerche MAMM
WEIGHT: 66 kg - m³: 0,63 - **PIECES:** 1

ART. 1798
CREDENZA ZERO

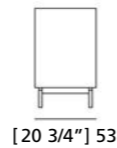
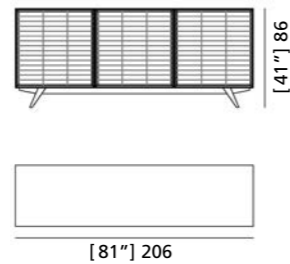

MISURE: L 206 P 53 H 86
DESCRIZIONE: credenza con struttura art. 3470 a 3 vani in legno di ciliegio della collezione Zero e 3 ante a mattoncini art. 3454. Ripiani interni regolabili. Disponibile con ante, cassetti e accessori della collezione Zero. Finitura: F60. Design Centro Ricerche MAMM.
PESO: 91 kg - m³: 0,94 - COLLI: 1

MEASURES: L 206 W 53 H 86
DESCRIPTION: sideboard made with a three-rooms Zero structure art. 3470 and 3 doors with brick inlay decoration art. 3454. Adjustable shelves. Available with doors, drawers and accessories of the Zero collection. Finishing: F60. Design by centro Ricerche MAMM.
WEIGHT: 91 kg - m³: 0,94 - PIECES: 1

ART. 1799
CREDENZA ZERO

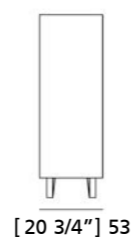
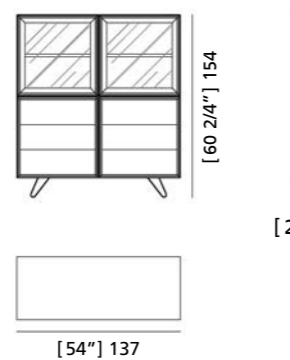

MISURE: L 137 P 53 H 154
DESCRIZIONE: credenza con struttura a 4 vani in legno di ciliegio e ripiani regola-bili. Due ante fresate e due ante a vetro. Disponibile con ante, cassetti e accessori della collezione Zero. Finitura: F32. Design Centro Ricerche MAMM.
PESO: 100 kg - m³: 1,30 - COLLI: 2

MEASURES: L 137 W 53 H 154
DESCRIPTION: sideboard with a four room zero structure made of cherry wood with adjustable shelves. Two doors with milling and two doors with glass. Available with other accessories of Zero collection. Design by centro Ricerche MAMM.
WEIGHT: 100 kg - m³: 1,30 - PIECES: 2

VARIANTI ANTE PER CREDENZE ZERO DOORS FOR ZERO CABINETS

ZERO ANTA MATTONCINI



ZERO ANTA FRESATA



ZERO ANTA OBLÒ



ZERO ANTA VETRO



ZERO ANTA A LISTELLI



ZERO ANTA FINESTRA



ZERO ANTA ONDA



ZERO ANTA ARCO



ZERO ANTA CODE



ZERO ANTA COLORE



ART. 1720/Z
MOBILE GIANO

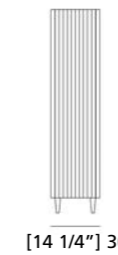
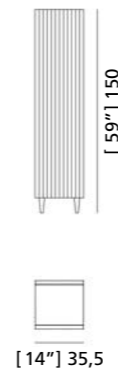

MISURE: L 35,5 P 36 H 150
DESCRIZIONE: mobiletto contenitore in legno di zebrano con particolare lavorazione delle superfici a lesene. Interno laccato con 3 ripiani regolabili. Specchio interno e gambette a spillo. Design: Ugo La Pietra
PESO: 35 kg - m³: 0,22 - COLLI: 1

MEASURES: L 35,5 W 36 H 150
DESCRIPTION: cabinet made of zebrano wood with a fine milling on the sides. Internally lacquered with 3 adjustable shelves. Internal mirror and conical legs
Design: Ugo La Pietra
WEIGHT: 35 kg - m³: 0,22 - PIECES: 1

ART. 1718
CREDENZA "CODE" CAVALLETTO

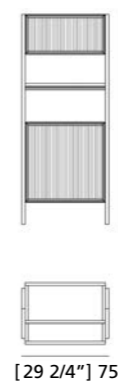

MISURE: L 75 P 53 H 180
DESCRIZIONE: mobile contenitore a 2 elementi più vano a giorno con mensola della collezione Zero. Struttura a "cavalletto" in legno di ciliegio con base art. 3494 e anta Code art. 3440; alzata art. 3491 con anta art. 3419. Disponibile con altre ante della collezione Zero. Finitura: F32. Design Centro Ricerche MAMM.
PESO: 60 kg - m³: 0,8 - COLLI: 1

MEASURES: L 75 W 53 H 180
DESCRIPTION: cabinet made of cherry wood with 2 closed elements and 1 open with shelf. The "cavalletto" structure consists of 1 base element art. 3494 with "Code" door art. 3440 and 1 upper element art. 3491 with door art. 3419. Also available with other doors of the Zero collection. Finishing: F32/C. Design by centro Ricerche MAMM.
WEIGHT: 60 kg - m³: 0,8 - PIECES: 1

ART. 1737
CREDENZA PORTA TV ZERO

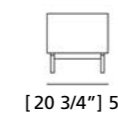
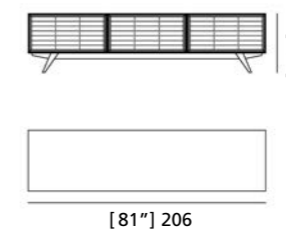



MISURE: L 206 P 53 H 51
DESCRIZIONE: credenza porta TV con struttura a 3 vani in legno di ciliegio della collezione Zero, 1 cassetto e 2 ante. Disponibile con ante, piedini e accessori della collezione Zero. Su richiesta struttura in noce canaleto. Finitura: F60. Design Centro Ricerche MAMM.
PESO: 80 kg - m³: 0,65 - COLLI: 1

MEASURES: L 206 W 53 H 51
DESCRIPTION: TV stand sideboard with a 3-rooms Zero element, 1 drawer and 2 doors. Available with doors, legs and accessories of the Zero collection. At the request structure in walnut. Finishing: F60. Design by centro Ricerche MAMM.
WEIGHT: 80 kg - m³: 0,65 - PIECES: 1

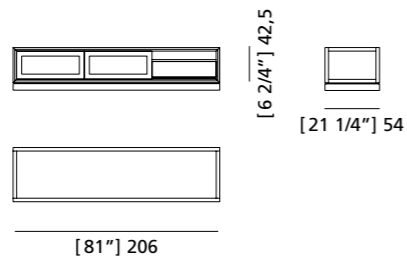
ART. 3353
MODULO '900 BASE PORTA TV





MISURE: L 206 P 54 H 42,5
DESCRIZIONE: modulo base in legno di ciliegio con 2 ante scorrevoli e 1 vano a giorno. Ripiani regolabili. Finitura: F60
Design centro Ricerche 
PESO: 55 kg - m³: 0,65
COLLI: 1

MEASURES: L 206 P 54 H 42,5
DESCRIPTION: modular base made of cherry wood with 2 sliding doors and 1 open compartment. Adjustable shelf. Finishing: F60
Design by Centro Ricerche 
WEIGHT: 55 kg - m³: 0,65
PIECES: 1

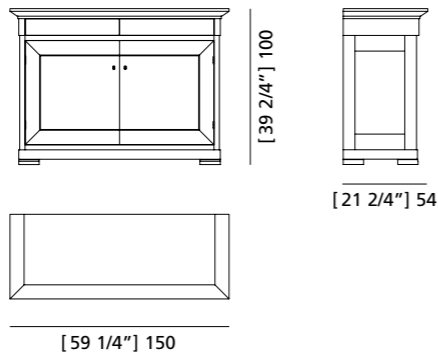
ART. 1788
CREDENZA BIEDERMEIER





MISURE: L 150 P 54 H 100
DESCRIZIONE: credenza in legno di ciliegio con 2 ante a battente e 2 cassetti a scomparsa. Ripiani interni regolabili. Finitura: F34
Design Centro Ricerche 
PESO: 68 kg - m³: 1
COLLI: 1

MEASURES: L 150 W 54 H 100
DESCRIPTION: sideboard made of cherry wood with 2 doors and 2 drawers. Adjustable shelves. Finishing: F34
Design by centro Ricerche 
WEIGHT: 68 kg - m³: 1
PIECES: 1

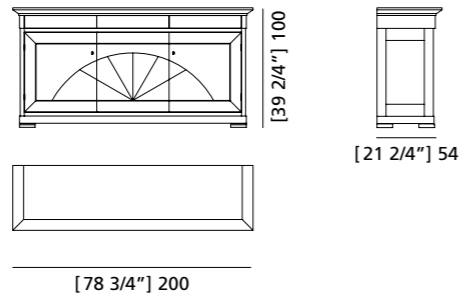
ART. 1785
CREDENZA BIEDERMEIER



MISURE: L 200 P 54 H 100
DESCRIZIONE: credenza in legno di ciliegio con particolare impiallacciatura ad arco sul frontale. 3 ante con ripiani interni regolabili e tre cassetti a scomparsa. Finitura: F34
Design Centro Ricerche 
PESO: 98 kg - m³: 1,24 - **COLLI:** 1

MEASURES: L 200 W 54 H 100
DESCRIPTION: sideboard made of cherry wood with a precious arch veneer on the front. 3 doors with adjustable internal shelves and three drawers. Finishing: F34
Design by centro Ricerche 
WEIGHT: 98 kg - m³: 1,24 - **PIECES:** 1

TAVOLI

TABLES



ART. 5733/F
TAVOLO JOYCE RETTANGOLARE
Art. 5701/F

CUSTOMIZABLE

MISURE: L 200 P 109 H 75

MISURE: L 240 P 109 H 75
DESCRIZIONE: Tavolo in legno di frassino con piano in vetro e particolari in ottone. Design: Libero Rutilo
PESO: 120 kg - m³: 2
COLLI: 2

MEASURES: L 240 P 109 H 75
DESCRIPTION: Table made of turned ash wood with glass top and brass tips. Design: Libero Rutilo
WEIGHT: 120 kg - m³: 2
PIECES: 2



[94 2/4"] 240

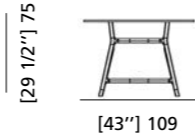

[43"] 109



ART. 5705/F
TAVOLO JOYCE ROTONDO
Art. 5734/F

CUSTOMIZABLE

MISURE: diam. 140 H 75

MISURE: diam. 120 H 75
DESCRIZIONE: Tavolo in legno di frassino con piano in vetro e particolari in ottone. Design: Libero Rutilo
PESO: 80 kg - m³: 1,5
COLLI: 2

MEASURES: diam. 120 H 75
DESCRIPTION: Table made of turned ash wood with glass top and brass tips. Design: Libero Rutilo
WEIGHT: 80 kg - m³: 1,5
PIECES: 2

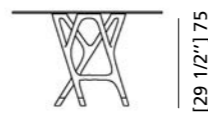

[29 1/2"] 75

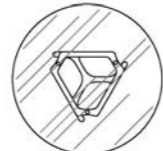

[47 1/4"] 120

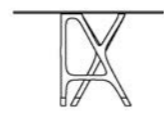

[47 1/4"] 120

ART. 5701/FPP
TAVOLO JOYCE RETTANGOLARE PIANO PIETRA

CUSTOMIZABLE

MISURE: L 200 P 109 H 75
DESCRIZIONE: Tavolo in legno di frassino con piano in pietra e particolari in ottone. Design: Libero Rutilo
PESO: 120 kg - m³: 2
COLLI: 2

MEASURES: L 240 P 109 H 75
DESCRIPTION: Table made of turned ash wood with stone top and brass tips. Design: Libero Rutilo
WEIGHT: 120 kg - m³: 2
PIECES: 2

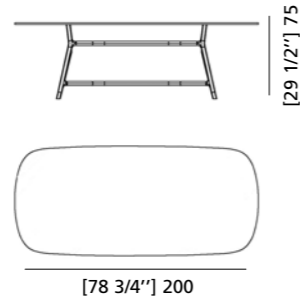

[78 3/4"] 200

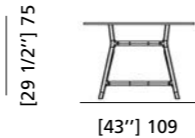

[43"] 109

ART. 5705/FPP
TAVOLO JOYCE ROTONDO

CUSTOMIZABLE

MISURE: diam. 120 H 75
DESCRIZIONE: Tavolo in legno di frassino con piano in pietra e particolari in ottone. Design: Libero Rutilo
PESO: 80 kg - m³: 1,5
COLLI: 2

MEASURES: diam. 120 H 75
DESCRIPTION: Table made of turned ash wood with stone top and brass tips. Design: Libero Rutilo
WEIGHT: 80 kg - m³: 1,5
PIECES: 2

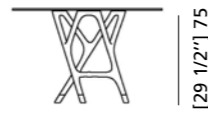

[29 1/2"] 75

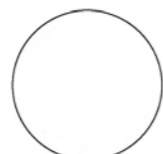

[47 1/4"] 120

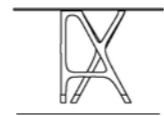

[47 1/4"] 120

ART. 5723/F
TAVOLO MARILYN ROTONDO
ART. 5724/F
TAVOLO MARILYN OVALE

Misure: L 160 P 120 H 75

MISURE: L 120 P 120 H 75
DESCRIZIONE: Tavolo con piano in legno di frassino e basamento conico in marmo con lavorazione a plissé. Design: Libero Rutilo
PESO: 100 kg - m³: 1,1 - COLLI: 1

MEASURES: L 120 P 120 H 75
DESCRIPTION: Table with ash wood top and conical base in pleated marble. Design by Libero Rutilo
WEIGHT: 100 kg - m³: 1,1 - PIECES: 1

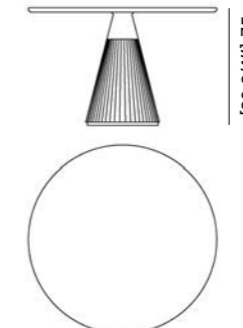

[29 2/4"] 75

[47 1/4"] 120

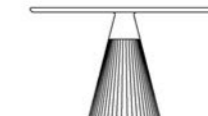

[47 1/4"] 120

ART. 5728/F
TAVOLO ITALO

CUSTOMIZABLE

MISURE: L 180 P 90 H 77
MISURE: L 140 P 140 H 77

MISURE: L 210 P 100 H 77
DESCRIZIONE: Tavolo in marmo con basamento in legno di frassino e puntali in ottone. Design: Centro Ricerche
PESO: 300 kg - m³: 2,5 - COLLI: 2

MEASURES: L 210 P 100 H 77
DESCRIPTION: Table made of ash wood with marble top and brass tips. Design by Centro Ricerche
WEIGHT: 300 kg - m³: 2,5 - PIECES: 2

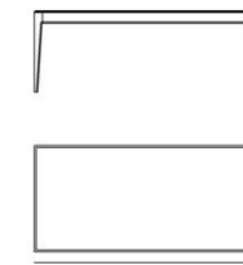

[30 1/3"] 77

[82 2/3"] 210



[39 2/5"] 100

ART. 5729/F
TAVOLO SPIDER

CUSTOMIZABLE

MISURE: L 180 P 110 H 75
MISURE: L 150 P 130 H 75

MISURE: L 200 P 110 H 75
DESCRIZIONE: Tavolo con piano in vetro e basamento in legno di frassino con particolari incastri. Design: Centro Ricerche
PESO: 70 kg - m³: 2 - COLLI: 2

MEASURES: L 200 P 110 H 75
DESCRIPTION: Table with glass top and ash wooden base with precious joints. Design by Centro Ricerche
WEIGHT: 70 kg - m³: 2 - PIECES: 2

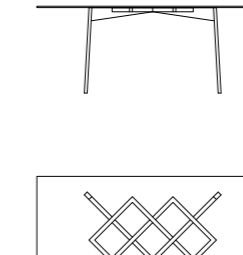

[29 1/2"] 75

[78 3/4"] 200

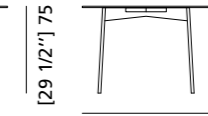

[43 1/3"] 110

ART. 5720/F
TAVOLO CAMPO

MISURE: L 230 P 97 H 77
DESCRIZIONE: tavolo in legno di frassino con gambe a forcella, il piano con venature contrapposte contiene al centro 5 vassoi estraibili. Finitura: tinta nero F140. Design: Franco Poli
PESO: 55 kg - m³: 1,9
COLLI: 1

MEASURES: L 230 W 97 H 77
DESCRIPTION: table made of ash wood with fork shaped legs, and table top with veneer pattern decoration. In the middle 5 removable trays. Finish: matt black F140. Design: Franco Poli
WEIGHT: 55 kg - m³: 1,9
PIECES: 1

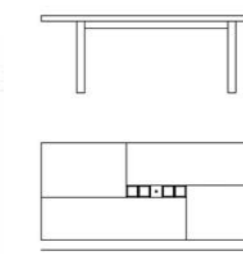

[30 1/4"] 77

[90 2/4"] 230



[30 1/4"] 97

ART. 5776/A
TAVOLO NORD SUD

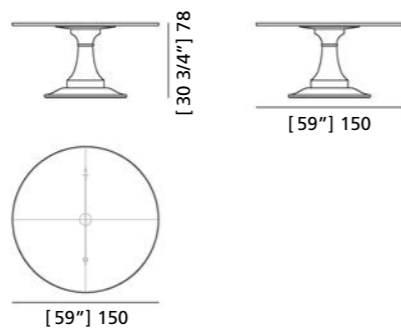

MISURE: diam. 150 H 78
DESCRIZIONE: tavolo rotondo in legno di acero con gambone centrale tornito. Sul piano un intarsio in ebano rappresenta un'asse nord - sud. Tavolo premiato tra i "Best Design 2006".
Design Centro Ricerche MAMM
PESO: 68 kg - m³: 0,75 - COLLI: 2

MEASURES: diam. 150 H 78
DESCRIPTION: round table made of maple wood with turned central leg. On the top an ebony inlay represents the north - south axis. Table awarded with the "Best Design 2006".
Design by Centro Ricerche MAMM
WEIGHT: 68 kg - m³: 0,75 - PIECES: 2

ART. 5709
TAVOLO LEONARDO

CUSTOMIZABLE

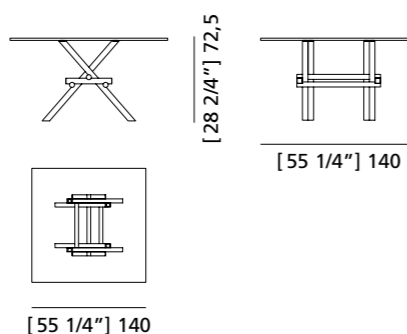

MISURE: L 140 P 140 H 72,5
DESCRIZIONE: tavolo con struttura in legno massello di frassino o noce e piano in cristallo. L'incastro delle gambe, privo di viti e incastri, è ispirato alla costruzione dei ponti mobili di Leonardo da Vinci. Design: Marco Ferreri
PESO: 100 kg - m³: 0,6 - COLLI: 2

MEASURES: L 140 W 140 H 72,5
DESCRIPTION: table made of solid ash or walnut wood with glass top. The joint of the legs, without any screws or metal joints, is inspired by the construction of movable bridges of Leonardo da Vinci. Design: Marco Ferreri
WEIGHT: 100 kg - m³: 0,6 - PIECES: 2

ART. 5710
TAVOLO LEONARDO

CUSTOMIZABLE

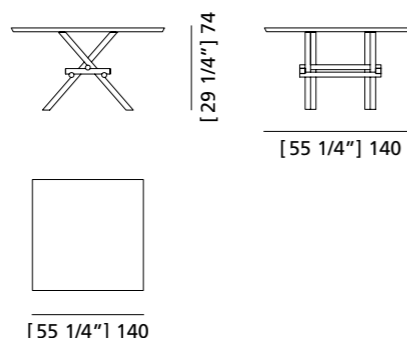

MISURE: L 140 P 140 H 74
DESCRIZIONE: tavolo con struttura e piano in legno di frassino o noce. L'incastro delle gambe, privo di viti e incastri, è ispirato alla costruzione dei ponti mobili di Leonardo da Vinci. Design: Marco Ferreri
PESO: 33 kg - m³: 0,6 - COLLI: 2

MEASURES: L 140 W 140 H 74
DESCRIPTION: table made of solid ash or walnut wood. The joint of the legs, without any screws or metal joints, is inspired by the construction of movable bridges of Leonardo da Vinci. Design: Marco Ferreri
WEIGHT: 33 kg - m³: 0,6 - PIECES: 2

ART. 5726
TAVOLO CAMPIELLO

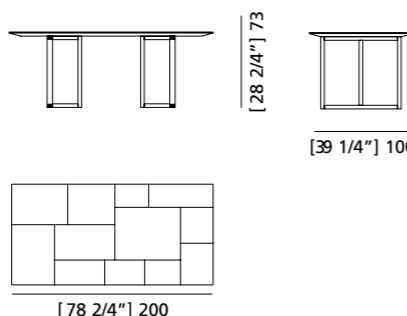

MISURE: L 200 P 100 H 73
DESCRIZIONE: tavolo fisso in legno di Wengè con piano composto da essenze di Ebano Makassar, Noce, Acero, Padouk e Ciliegio. Particolare del piano il taglio a sguancio che lo rende sottile. Gambe in legno massello di Wengè. Finitura F32
Design Maurizio Duranti.
PESO: 75 kg - m³: 0,62 - COLLI: 2

MEASURES: L 200 W 100 H 73
DESCRIPTION: fixed table made of wenge wood. The top veneered with Makassar Ebony, Walnut, Maple, Cherry and Padauk. Splay cut top. Legs made of solid Wengè. Finishing: F32
Design by Maurizio Duranti.
WEIGHT: 75 kg - m³: 0,62 - PIECES: 2

ART. 5795
TAVOLO CARTESIA

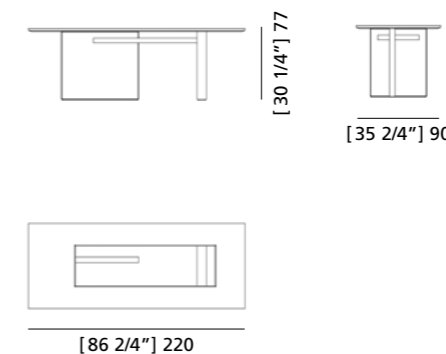

MISURE: L 220 P 90 H 77
DESCRIZIONE: tavolo con piano e mensola in acero e gambe in noce. Nel piano è ricavato un cristallo centrale. Finitura: F32/A e F32/N
Design Franco Poli.
PESO: 120 kg - m³: 0,45
COLLI: 2

MEASURES: L 220 W 90 H 77
DESCRIPTION: table with top and shelf made of maple wood and walnut legs. Glass top insert in the middle. Finishing: F32/A e F32/N
Design by Franco Poli.
WEIGHT: 120 kg - m³: 0,45
PIECES: 2

ART. 5794/A
TAVOLO AERO

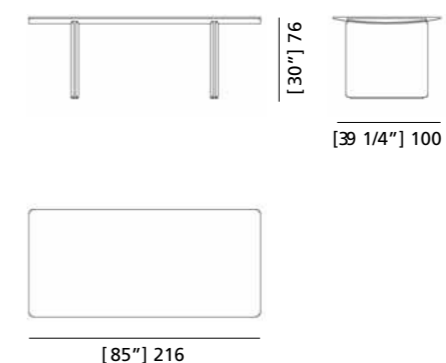

MISURE: L 216 P 100 H 76
DESCRIZIONE: tavolo con ossatura interna a comparti e pregiata impiallacciatura curvata in legno di acero. La costruzione è ispirata alla struttura delle ali di un aereo. Finitura: F32/A
Design Franco Poli.
PESO: 84 kg - m³: 1,70 - COLLI: 1

MEASURES: L 216 W 100 H 76
DESCRIPTION: table with internal wooden skeleton and fine curved maple wood veneer. The construction is inspired by airplane wing structure. Finishing: F32/A
Design by Franco Poli.
WEIGHT: 84 kg - m³: 1,70 - PIECES: 1

ART. 5712/F
TAVOLO TRIDENT

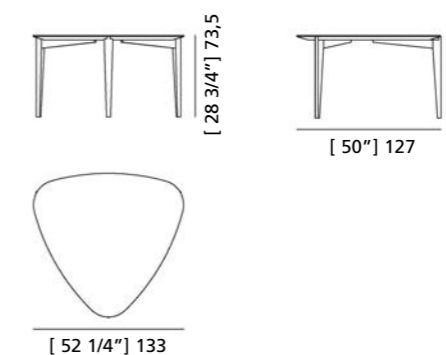

MISURE: Lato 133 P 127 H 73,5
DESCRIZIONE: tavolo in legno di frassino con piano triangolare e lavorazione a sguancio dei bordi. Design Centro Ricerche MAMM
PESO: 50 kg - m³: 0,85
COLLI: 2

MEASURES: Side 133 P 127 H 73,5
DESCRIPTION: table made of ash wood with triangular top and splay cut edge. Design by centro Ricerche MAMM
WEIGHT: 50 kg - m³: 0,85
PIECES: 2

ART. 5721
TAVOLO BOOMERANG

CUSTOMIZABLE

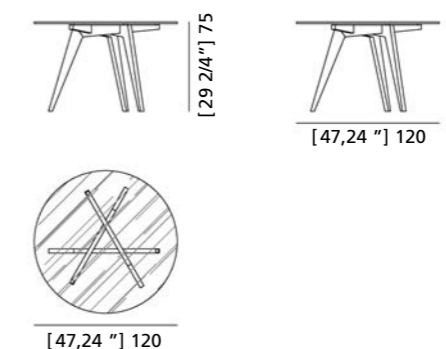

MISURE: diam. 120 H 75
DESCRIZIONE: piano in cristallo e gambe in ciliegio a forma di boomerang, unite con particolare incastro a pettine. Finitura: F100.
Design Centro Ricerche MAMM
PESO: 28 kg - m³: 0,70
COLLI: 1

MEASURES: diam. 120 H 75
DESCRIPTION: glass top and legs made of cherry wood in a "boomerang" shape dovetail joint assembly. Finishing: F100.
Design by centro Ricerche MAMM
WEIGHT: 28 kg - m³: 0,70
PIECES: 1

ART. 5717/F
TAVOLO MALIBÙ

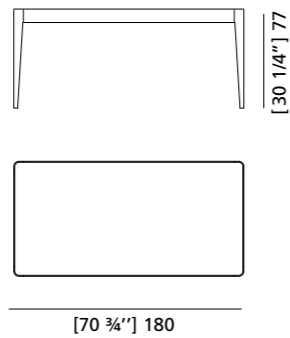

[70 3/4"] 180

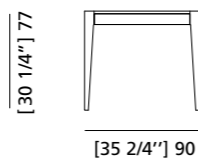

[35 2/4"] 90

MISURE: L 180 P 90 H 77
DESCRIZIONE: Tavolo in legno di frassino con due grandi cassetti laterali contenenti 2 prolunghe da 45cm.
Design Centro Ricerche MAMM
PESO: 63 kg - m³: 1,30
COLLI: 2

MEASURES: L 180 W 90 H 77
DESCRIPTION: Table made of ash wood with two big drawers containing 2 extensions of 45 cm each.
Design by Centro Ricerche MAMM
WEIGHT: 63 kg - m³: 1,30
PIECES: 2

ART. 5799
TAVOLO FLAMINIA

ART. 5722
TAVOLO FLAMINIA MISURE: L 180 P 90 H 78
ALLUNGABILE FINO A L 270

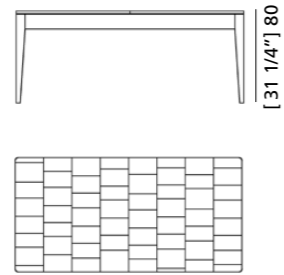

[78 3/4"] 200

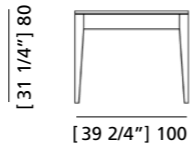

[39 2/4"] 100

MISURE: L 200 P 100 H 80
DESCRIZIONE: tavolo allungabile in legno di ciliegio con pregiata impiallacciatura del piano a venature contrapposte, 2 prolunghe interne da 50cm.
Finitura: F34. Design Centro Ricerche MAMM
MISURE APERTO: L 300 P 100 H 80
PESO: 90 kg - m³: 1,87 - COLLI: 1

MEASURES: L 200 W 100 H 80
DESCRIPTION: extendable table made of cherry wood, veneered with a fine grain misalignment of the top. 2 internal extensions of 50 cm. Finishing: F34
Design by centro Ricerche MAMM
SIZE OPEN: L 300 W 100 H 80
WEIGHT: 90 kg - m³: 1,87 - PIECES: 1

ART. 5769
TAVOLO LUIGI XV

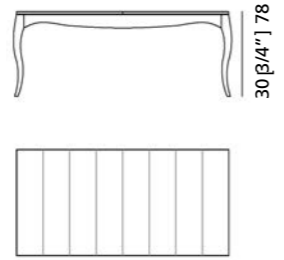

[78 3/4"] 200

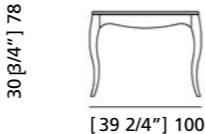

[39 2/4"] 100

MISURE: L 200 P 100 H 78
DESCRIZIONE: tavolo rettangolare allungabile in legno di ciliegio con pregiata impiallacciatura del piano a spina di pesce. Gambe e profili sagomati. 2 prolunghe interne da 50cm. Finitura: F34.
Design Centro Ricerche MAMM
MISURE APERTO: L 300 P 100 H 78
PESO: 90 kg - m³: 1,8 - COLLI: 1

MEASURES: L 200 W 100 H 78
DESCRIPTION: rectangular extendable table made of cherry wood with prestigious fish-bone veneer. 2 internal extensions of 50 cm. Finishing: F34.
Design by centro Ricerche MAMM
OPEN SIZE: L 300 P 100 H 78
WEIGHT: 90 kg - m³: 1,8 - PIECES: 1

ART. 5775
TAVOLO BIEDERMEIER

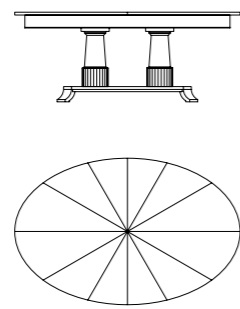

[78 3/4"] 200

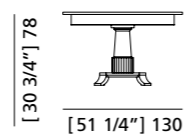

[51 1/4"] 130

MISURE: L 200 P 130 H 78
DESCRIZIONE: tavolo ovale allungabile in legno di ciliegio con 2 gamboni intarsiati e impiallacciatura del piano a raggiera. 1 prolunga interna da 50cm. Finitura: F34
Design Centro Ricerche MAMM
MISURE APERTO: L 250 P 130 H 78
PESO: 100 kg - m³: 2,35 - COLLI: 1

MEASURES: L 200 W 130 H 78
DESCRIPTION: oval extendable table made of cherry wood with 2 carved legs and radial veneered top. 1 internal extension of 50 cm. Finishing: F34
Design by centro Ricerche MAMM
OPEN SIZE: L 250 P 130 H 78
WEIGHT: 100 kg - m³: 2,35 - PIECES: 1

ART. 5779
TAVOLO BIEDERMEIER

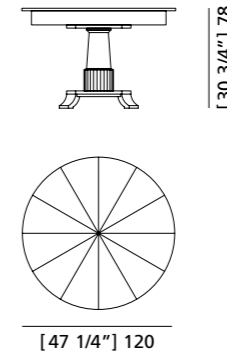

[47 1/4"] 120

[30 3/4"] 78

MISURE: diam. 120 H 78
DESCRIZIONE: tavolo rotondo allungabile in legno di ciliegio con gambone intarsiato centrale e impiallacciatura del piano a raggiera. 1 prolunga interna da 40cm. Finitura: F34
Design Centro Ricerche MAMM
MISURE APERTO: L 160 H 78
PESO: 65 kg - m³: 1,25 - COLLI: 1

MEASURES: diam. 120 H 78
DESCRIPTION: round extendable table made of cherry wood with 1 central carved leg and radial veneered top. 1 internal extension of 40 cm. Finishing: F34
Design by centro Ricerche MAMM
OPEN SIZE: L 160 H 78
WEIGHT: 65 kg - m³: 1,25 - PIECES: 1

ART. 5782
TAVOLO BIEDERMEIER

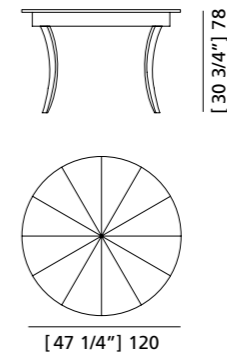

[47 1/4"] 120

[30 3/4"] 78

MISURE: diam. 120 H 78
DESCRIZIONE: tavolo rotondo allungabile in legno di ciliegio con impiallacciatura del piano a raggiera e gambe curvate. 1 prolunga interna da 40 cm. Finitura: F34
Design Centro Ricerche MAMM
MISURE APERTO: L 160 H 78
PESO: 57 kg - m³: 1,3 - COLLI: 1

MEASURES: diam. 120 H 78
DESCRIPTION: round extendable table made of cherry wood with 4 shaped legs and radial veneered top. 1 internal extension of 40 cm. Finishing: F34
Design by centro Ricerche MAMM
OPEN SIZE: L 160 H 78
WEIGHT: 57 kg - m³: 1,3 - PIECES: 1

ART. 5768
TAVOLO DIRETTORIO

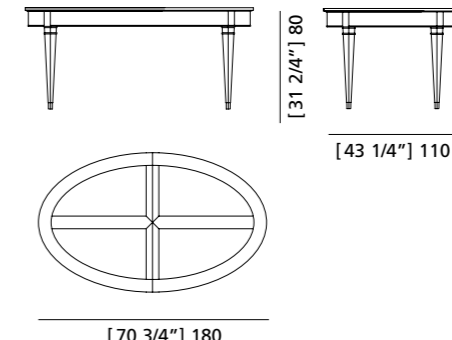

[70 3/4"] 180

[31 2/4"] 80

[43 1/4"] 110

MISURE: L 180 P 110 H 80
Allungabile fino a cm 330.
Altezza da sottopiano a terra cm 64.
DESCRIZIONE: tavolo ovale allungabile in legno di ciliegio. Struttura interna in legno con 3 allunghe da 50cm e 1 gamba a scomparsa di sostegno. Finitura: F60
Design Centro Ricerche MAMM
PESO: 92 kg - m³: 1,6 - COLLI: 2

MEASURES: L 180 W 110 H 80
Maximum extension of the top cm 330. Height from underneath frame to the ground cm 64.
DESCRIPTION: oval extendable table made of cherry wood with 3 internal extensions of 50 cm and 1 hidden supporting leg. Finishing: F60
Design by centro Ricerche MAMM
WEIGHT: 92 kg - m³: 1,6 - PIECES: 2

ART. 5744
TAVOLO DIRETTORIO

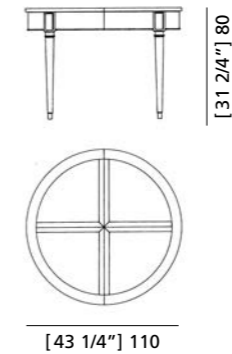

[43 1/4"] 110

[31 2/4"] 80

MISURE: diam. 110 H 80
Altezza da sottopiano a terra cm 64.
Allungamento del piano fino a cm 230.
DESCRIZIONE: tavolo rotondo allungabile con piano lastronato e struttura in legno di ciliegio. 3 allunghe esterne di 40cm, 2 di esse con sponda laterale. Finitura: F60. Design Centro Ricerche MAMM
PESO: 75 kg - m³: 0,9 - COLLI: 2

MEASURES: diam. 110 H 80
Height from underneath frame to the ground cm 64. Maximum extension of the top cm 230.
DESCRIPTION: Round extendable table made of cherry wood. Inner wooden structure extendable up to 230 cm through 3 extensions of 40 cm. Finishing: F60. Design by centro Ricerche MAMM
WEIGHT: 75 kg - m³: 0,9 - PIECES: 2



SCRIVANIE

WRITING-DESKS

ART. 5004/F
SCRIVANIA ISABEL
SCRIVANIA ISABEL - PIANO IN LEGNO € 8.015

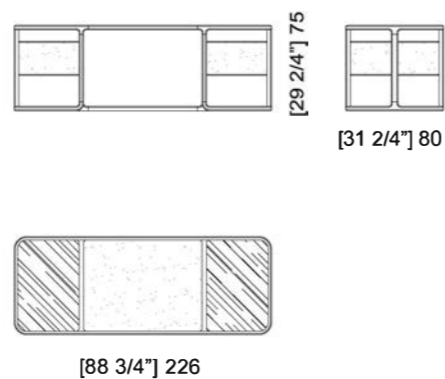

MISURE: L 226 P 80 H 75
DESCRIZIONE: Scrivania bifacciale in legno di frassino tornito con piani laterali in vetro e piano centrale rivestito in cuoio. Presenta 2 piani a giorno e 2 cassettoni con apertura push&pull contenenti 2 vani porta oggetti segreti. Cassettoni rivestiti in cuoio sui lati. Design Libero Rutilo
PESO: 80 kg - m³: 1,5 - COLLI: 3

MEASURES: L 226 W 80 H 75
DESCRIPTION: two-sided desk in turned ash wood with side worktops in glass and central top covered in leather. The desk has 2 open worktops and 2 drawers with push&pull opening, containing 2 secret storage compartments. Drawers covered in leather on the sides. Design by Libero Rutilo.
WEIGHT: 80 kg - m³: 1,5 - PIECES: 3

ART. 5081
SCRIVANIA PRESIDENT

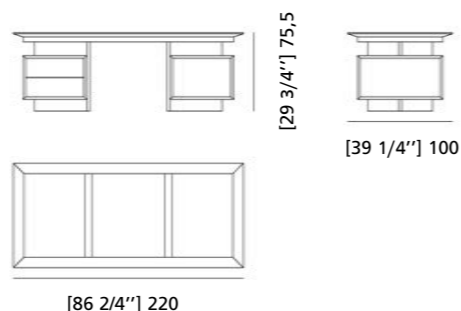

MISURE: L 220 P 100 H 75,5
DESCRIZIONE: Scrivania bifacciale in legno di ciliegio con due basamenti che racchiudono ampi contenitori chiusi da ante e cassetti a scomparsa. Piano con pregiato rivestimento in pelle. Finitura: F160. Design Centro Ricerche MAMM
PESO: 130 kg - m³: 1,1 - COLLI: 3

MEASURES: L 220 W 100 H 75,5
DESCRIPTION: Double sided writing desk with two base parts containing large modules with doors and drawers. Top with precious leather inserts. Finish: F160. Design by centro Ricerche MAMM
WEIGHT: 130 kg - m³: 1,1 - PIECES: 3

ART. 5078
SCRIVANIA ROMA

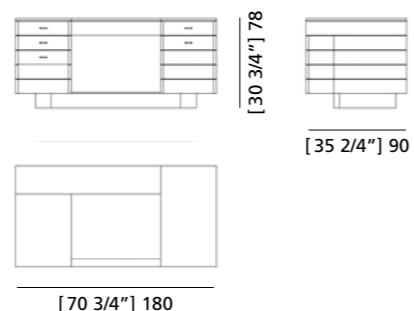

MISURE: L 180 P 90 H 78
DESCRIZIONE: scrivania professionale in legno di ciliegio con piano di scrittura in pelle rivestito e comparto sottostante. Vano porta computer con passacavi e cassetto porta schede. Il mobile è impreziosito con vari cassetti e vani nascosti. Finitura: F30
ALTRE MISURE: vano sotto piano L 80 H 65
PESO: 135 kg - m³: 1,4 - COLLI: 1-3

MEASURES: L 180 W 90 H 78
DESCRIPTION: Professional writing desk made of cherry wood with leather coated writing top and hidden compartment. PC room and file drawer. Made precious by various drawers and hidden spaces. Finishing: F30
WEIGHT: 135 kg - m³: 1,4 - PIECES: 1-3

ART. 5051
SCRIVANIA FLAMINIA

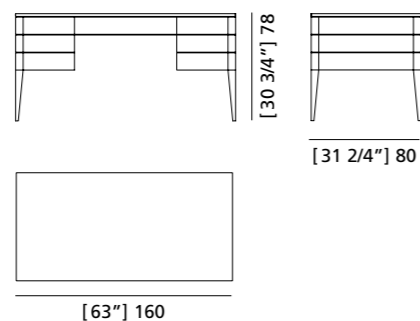

MISURE: L 160 P 80 H 78
DESCRIZIONE: Scrivania bifacciale in legno di ciliegio con piano in legno, 6 cassetti laterali e 1 cassetto centrale a scomparsa. Finitura: F.34
Misure da sottopiano a terra: 62 cm. Design Centro Ricerche MAMM
PESO: 95 kg - m³: 1,2 - COLLI: 1

MEASURES: L 160 W 80 H 78
DESCRIPTION: writing desk made of cherry wood with wooden top, 6 side drawers and 1 central drawer. Finishing: F34
Height from underneath the frame to the ground: 62 cm. Design by centro Ricerche MAMM
WEIGHT: 95 kg - m³: 1,2 - PIECES: 1

ART. 5002/F
SCRITTOIO BELLAGIO

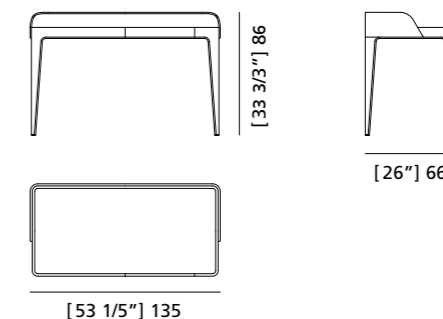

MISURE: L 135 P 66 H 86
DESCRIZIONE: Scrittoio in legno di frassino con piano in pelle e cassetto porta oggetti. Design Libero Rutilo.
PESO: 55 kg - m³: 1 - COLLI: 1

MEASURES: L 135 W 66 H 86
DESCRIPTION: Writing desk made of ash wood with leather top and one drawer. Design by Libero Rutilo.
WEIGHT: 55 kg - m³: 1 - PIECES: 1

ART. 5003/F
SCRITTOIO SWING

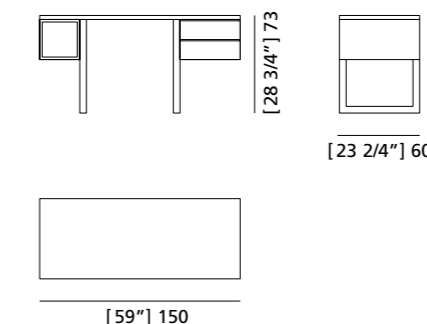

MISURE: L 150 P 60 H 73
DESCRIZIONE: Scrittoio in legno di frassino, due cassetti a destra, un vano a giorno a sinistra. Sul retro due vani a giorno. Interni colorati. Finitura F32/F. Design Libero Rutilo
PESO: 45 kg - m³: 0,65 - COLLI: 1

MEASURES: L 150 P 60 H 73
DESCRIPTION: Desk in ash wood with 2 drawers and open elements on left and back. Finitura F32/F. Design Libero Rutilo
WEIGHT: 45 kg - m³: 0,65 - PIECES: 1

ART. 5080
SCRITTOIO EUGENIO

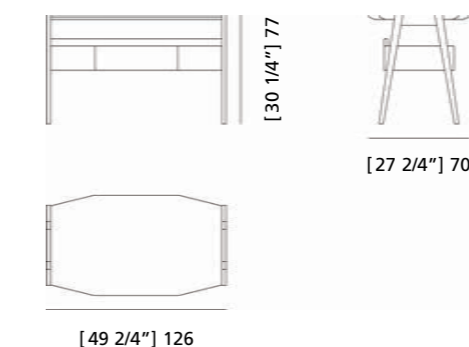

MISURE: L 126 P 70 H 77
DESCRIZIONE: Scrittoio in legno di frassino con piano ottagonale e due cassetti laterali con vano a giorno. Design Centro Ricerche MAMM
PESO: 43 kg - m³: 0,9
COLLI: 1

MEASURES: L 126 W 70 H 77
DESCRIPTION: Writing desk made of ash wood with octagonal top, 2 drawers and open space. Design by centro Ricerche MAMM
WEIGHT: 43 kg - m³: 0,9
PIECES: 1

ART. 5075
SCRIVANIA DIRETTORIO

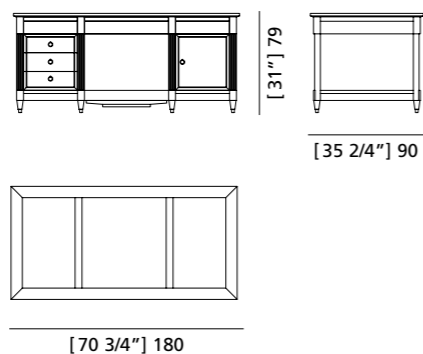

MISURE: L 180 P 90 H 79
DESCRIZIONE: scrivania in legno di ciliegio con pregiati rivestimenti in pelle sul piano, 4 cassetti, 1 cassetto porta schede e vano porta pc. Finitura: F60 Design Centro Ricerche MAM
PESO: 113 kg - m³: 1,5
COLLI: 1

MEASURES: L 180 W 90 H 79
DESCRIPTION: writing desk made of cherry wood with precious leather top. 4 drawers, 1 PC space and file drawers. Finishing: F60 Design by centro Ricerche MAM
WEIGHT: 113 kg - m³: 1,5
PIECES: 1

ART. 5069
SCRIVANIA DIRETTORIO

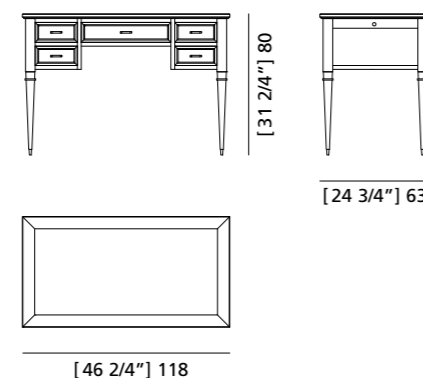

MISURE: L 118 P 63 H 80
DESCRIZIONE: scrivania in legno di ciliegio con pregiato rivestimento in pelle sul piano, 5 cassetti e 2 tiri a scomparsa sui lati. Finitura: F60 Design Centro Ricerche MAM
PESO: 47 kg - m³: 0,7 - **COLLI:** 1

MEASURES: L 118 W 63 H 80
DESCRIPTION: writing desk made of cherry wood with precious leather top. 5 drawers and 2 hidden drawers on the sides. Finishing: F60 Design by centro Ricerche MAM
WEIGHT: 47 kg - m³: 0,7 - **PIECES:** 1

ART. 5070
SCRIVANIA DIRETTORIO

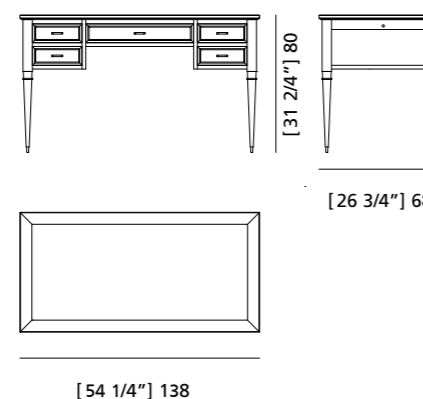

MISURE: L 138 P 68 H 80
DESCRIZIONE: scrivania in legno di ciliegio con pregiato rivestimento in pelle sul piano, 5 cassetti e 2 tiri a scomparsa sui lati. Finitura: F60 Design Centro Ricerche MAM
PESO: 56 kg - m³: 0,87 - **COLLI:** 1

MEASURES: L 138 W 68 H 80
DESCRIPTION: writing desk made of cherry wood with precious leather top. 5 drawers and 2 hidden drawers on the sides. Finishing: F60 Design by centro Ricerche MAM
WEIGHT: 56 kg - m³: 0,87 - **PIECES:** 1



SEDIE
POLTRONCINE
POLTRONCINE
GIREVOLI
SGABELLI

CHAIRS
ARMCHAIRS
SWIVEL CHAIRS
STOOLS

ART. 5103/F
SEDIA JOYCE

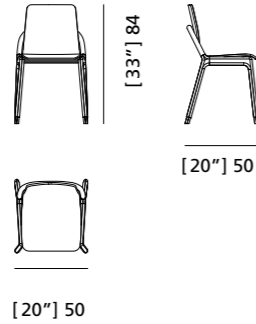

MISURE: L 50 P 50 H 84 SH 46
DESCRIZIONE: Sedia in legno di frassino con seduta imbottita e puntali in ottone. Tessuto occorrente 100x140 cm Design: Libero Rutilo.
PESO: 9 kg - m³: 0,2 - **COLLI:** 1

MEASURES: L 50 P 50 H 84 SH 46
DESCRIPTION: Chair made of turned ash wood with upholstered seat and brass tips. Required material 100x140 cm Design by Libero Rutilo
WEIGHT: 9 kg - m³: 0,2 - **PIECES:** 1

ART. 3817/F
POLTRONCINA JOYCE

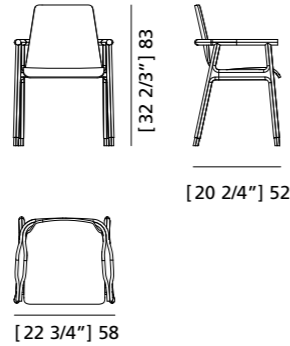

MISURE: L 58 P 52 H 83 SH 46
DESCRIZIONE: Sedia con braccioli in legno di frassino con seduta imbottita e puntali in ottone. Tessuto occorrente 100x140 cm Design Libero Rutilo
PESO: 10 kg - m³: 0,3 - **COLLI:** 1

MEASURES: L 58 P 52 H 83 SH 46
DESCRIPTION: Armchair made of turned ash wood with upholstered seat and brass tips. Required material 100x140 cm Design Libero Rutilo
WEIGHT: 10 kg - m³: 0,3 - **PIECES:** 1

ART. 5104/F
SEDIA BELLAGIO

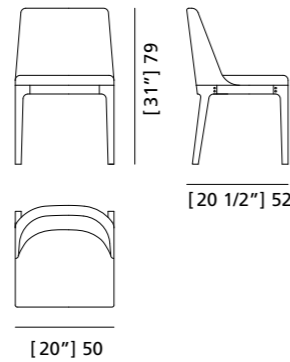

MISURE: L 50 P 52 H 79 HS 48
DESCRIZIONE: Sedia in legno di frassino con seduta imbottita. Tessuto occorrente 120x140 cm Design: Libero Rutilo.
PESO: 15 kg - m³: 0,3 - **COLLI:** 1

MEASURES: L 50 P 52 H 79 HS 48
DESCRIPTION: Chair made of ash wood with upholstered seat. Required material 120x140 cm Design by Libero Rutilo
WEIGHT: 15 kg - m³: 0,3 - **PIECES:** 1

ART. 3809/F
POLTRONCINA BELLAGIO

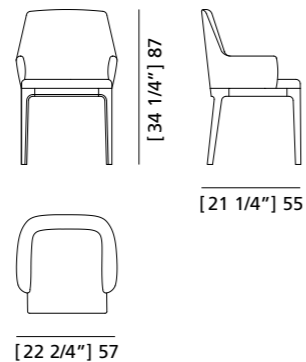

MISURE: L 57 P 55 H 87 HS 48
DESCRIZIONE: Poltroncina in legno di frassino con braccioli e seduta imbottita. Tessuto occorrente 140x140 cm Design Libero Rutilo.
PESO: 17 kg - m³: 0,3 - **COLLI:** 1

MEASURES: L 57 P 55 H 87 HS 48
DESCRIPTION: Chair made of ash wood with upholstered seat. Required material 140x140 cm Design by Libero Rutilo
WEIGHT: 17 kg - m³: 0,3 - **PIECES:** 1

ART. 5107/N
SEDIA INGE

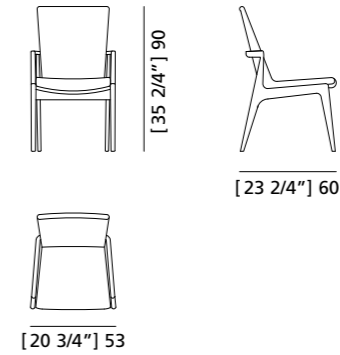

MISURE: L 53 P 60 H 90
DESCRIZIONE: Sedia imbottita con struttura in legno massello di noce canaletto. Tessuto occorrente: 170x140 cm Design Centro Ricerche MAMM
PESO: 12 kg - m³: 0,30
COLLI: 1

MEASURES: L 53 W 60 H 90
DESCRIPTION: Chair made of Canaletto walnut wood. Required fabric: 170x140 cm Design by centro Ricerche MAMM
WEIGHT: 12 kg - m³: 0,30
PIECES: 1

ART. 5102/F
SEDIA JENNY

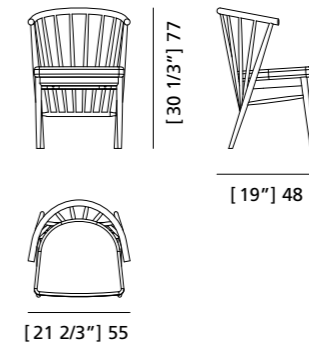

MISURE: L 55 P 48 H 77 HS 45
DESCRIZIONE: Sedia in legno di frassino con seduta imbottita. Tessuto occorrente 70x140 cm Design Centro Ricerche MAMM
PESO: 9 kg - m³: 0,3 - **COLLI:** 1

MEASURES: L 55 P 48 H 77 HS 45
DESCRIPTION: Chair made of turned ash wood with upholstered seat. Required material 70x140 cm Design by centro Ricerche MAMM
WEIGHT: 9 kg - m³: 0,3 - **PIECES:** 1

ART. 3805/F
POLTRONCINA JENNY

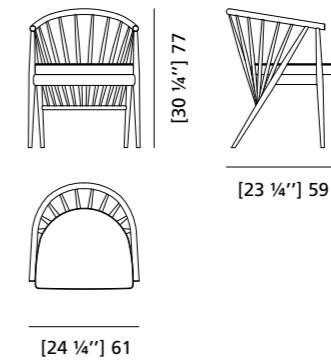

MISURE: L 61 P 59 H 77 HS 45
DESCRIZIONE: Poltroncina in legno massello di frassino con seduta imbottita. Lo schienale curvato appoggia su una fila di listelli di frassino fissati a diverse inclinazioni. Finitura: F32. Tessuto occorrente: cm 90x140 Design Centro Ricerca MAMM
PESO: 9 kg - m³: 0,3 - **COLLI:** 1

MEASURES: L 61 W 59 H 77 HS 45
DESCRIPTION: Armchair made of solid ash wood with upholstered seat. The curved back is made of a row of ash poles fixed at different angles. Finishing: F32. Required fabric: 90x140 cm Design Centro Ricerche MAMM
WEIGHT: 9 kg - m³: 0,3 - **PIECES:** 1

ART. 5197/F
SEDIA CARAMBOLA

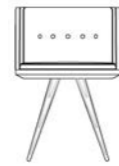

[30 3/4"] 78



[22 3/4"] 58



[20 3/4"] 53

MISURE: L 53 P 58 H 78 HS 48
DESCRIZIONE: Sedia imbottita in legno di frassino con gambe tornite a stecca da biliardo in legno di ciliegio, wengè e acero. Finitura: F32.
Tessuto occorrente: cm 150x140
Design Maurizio Duranti
PESO: 11 kg - m³: 0,2 **COLLI:** 1

MEASURES: L 53 W 58 H 78 HS 48
DESCRIPTION: Chair made of ash wood with turned legs in the shape of billiard cues made of cherry, maple and wengè wood. Upholstered back and seat. Finishing: F32.
Required fabric: 70x140
Design Maurizio Duranti
WEIGHT: 11 kg - m³: 0,2 **PIECES:** 1

ART. 3893/F
POLTRONCINA RONSON

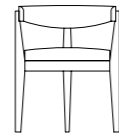

[27 1/4"] 69



[20 2/4"] 53

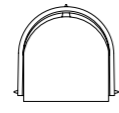

[22"] 56

MISURE: L 56 P 53 H 69 HS 43
DESCRIZIONE: Poltroncina con 3 gambe a sezione triangolare in legno di frassino con schienale curvato e seduta imbottita. Tessuto occorrente: cm 70x140. Finitura: F80. Design Centro Ricerche MAAM

MEASURES: L 56 W 53 H 69 HS 43
DESCRIPTION: armchair with 3 triangular legs made of ash wood with curved back and upholstered seat. Required fabric: 70x140 cm. Finishing: F80.
Design by centro Ricerche MAAM
WEIGHT: 10 kg - m³: 0,3 - **PIECES:** 1

ART. 5105/F
SEDIA SAVINA

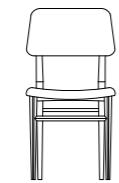

[33 2/4"] 85



[21 2/4"] 55



[18 2/4"] 47

MISURE: L 47 P 55 H 85 HS 47
DESCRIZIONE: sedia con schienale imbottito. Le gambe a sezione triangolare alleggeriscono la struttura in legno di frassino. Tessuto occorrente: cm 140x70. Design Centro Ricerche MAAM

MEASURES: L 47 W 55 H 85 HS 47
DESCRIPTION: chair with upholstered backrest. The triangular legs make the ash wood frame very light. Required fabric: 140x70 cm. Design by Centro Ricerche MAAM
WEIGHT: 8 kg - m³: 0,17 **PIECES:** 1

ART. 3880
POLTRONCINA BRAMANTE



[28 3/4"] 73



[19 3/4"] 50



[23 2/4"] 60

MISURE: L 60 P 50 H 73 HS 45
DESCRIZIONE: poltroncina in legno di acero e noce canaletto con schienale curvato e seduta imbottita. Tessuto occorrente: cm 70x140. Finitura: F32. Design Franco Poli.
PESO: 10 kg - m³: 0,25 **COLLI:** 1

MEASURES: L 60 W 50 H 73 HS 45
DESCRIPTION: armchair made of maple and walnut wood with curved back and upholstered seat. Required fabric: 70x140 cm. Finishing: F32.
Design by Franco Poli.
WEIGHT: 10 kg - m³: 0,25 **PIECES:** 1

ART. 3890/F
POLTRONCINA COOPER

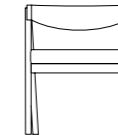

[27 1/4"] 69



[23 1/4"] 59

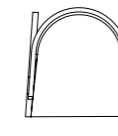

[22 3/4"] 58

MISURE: L 58 P 59 H 69 HS 45
DESCRIZIONE: poltroncina in legno di frassino con schienale curvato e seduta imbottita. Tessuto occorrente: cm 70x140. Finitura: F32/C. Design Centro Ricerche MAAM

MEASURES: L 58 W 59 H 69 HS 45
DESCRIPTION: Armchair made of ash wood with curved back and upholstered seat. Required fabric: 70x140 cm. Finishing: F32/C.
Design by centro Ricerche MAAM
WEIGHT: 14 kg - m³: 0,3 **PIECES:** 1

ART. 3891
POLTRONCINA BURTON

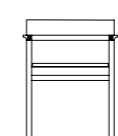

[28 3/4"] 73

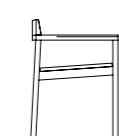

[20 3/4"] 53

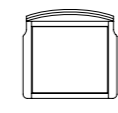

[22"] 56

MISURE: L 56 P 53 H 73 HS 47
DESCRIZIONE: poltroncina in legno di ciliegio con seduta imbottita e particolari incastri a pettine. Su richiesta anche in legno di noce. Tessuto occorrente: cm 70x140. Finitura: F32/C. Design Centro Ricerche MAAM

MEASURES: L 56 W 53 H 73 HS 47
DESCRIPTION: armchair made of cherry wood with upholstered seat. Upon request available in walnut wood. Required fabric: 70x140 cm. Finishing: F32/C. Design by centro Ricerche MAAM
WEIGHT: 12 kg - m³: 0,28 **PIECES:** 1

ART. 5194
SEDIA BURTON

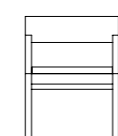

[28 3/4"] 73

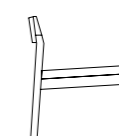

[18 3/4"] 48

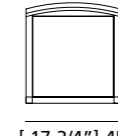

[17 2/4"] 45

MISURE: L 45 P 48 H 73 HS 45
DESCRIZIONE: sedia in legno di ciliegio con seduta imbottita e particolari incastri a pettine. A richiesta disponibile in legno di noce e frassino. Tessuto occorrente: cm 70x140. Design Centro Ricerche MAAM

MEASURES: L 45 W 48 H 73 HS 45
DESCRIPTION: chair made of cherry wood with upholstered seat. Upon request available in walnut and ash wood. Required fabric: 70x140 cm. Design by centro Ricerche MAAM
WEIGHT: 8 kg - m³: 0,17 **PIECES:** 1

ART. 5188
SEDIA CIAK

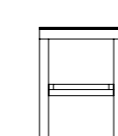

[29 3/4"] 76



[19 2/4"] 50

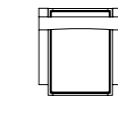

[18 1/4"] 46

MISURE: L 46 P 50 H 76 HS 46
DESCRIZIONE: sedia pieghevole in legno di frassino con seduta in pelle rivestita. Tessuto occorrente: cm 70x70. Finitura: F30. Design Centro Ricerche MAAM

ALTRE MISURE: sedia chiusa L 46 P 5 H 83
PESO: 9,5 kg - m³: 0,05 - **COLLI:** 1
MEASURES: L 46 W 50 H 76 HS 46
DESCRIPTION: folding chair made of ash wood with leather upholstered seat. Required fabric: 70x70 cm. Finishing: F30.
Design by centro Ricerche MAAM
WEIGHT: 9,5 kg - m³: 0,05 - **PIECES:** 1

ART. 3881/A
POLTRONCINA CARTESIA

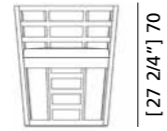

MISURE: L 60 P 50 H 70 HS 46
DESCRIZIONE: Poltroncina in legno di acero curvato con seduta imbottita. Su richiesta in legno di ciliegio o noce canaletto. Tessuto Occorrente: cm 70x140. Finitura: F32/A. Design Franco Poli.
PESO: 12 kg - m³: 0,25 - **COLLI:** 1

MEASURES: L 60 W 50 H 70 HS 46
DESCRIPTION: Armchair made of curved maple wood with upholstered seat. Upon request made of cherry wood or walnut. Required fabric: 70x140 cm. Finishing: F32/A. Design by Franco Poli.
WEIGHT: 12 kg - m³: 0,25 - **PIECES:** 1

ART. 3806
POLTRONCINA ROBERTA

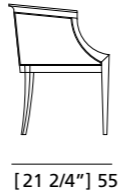
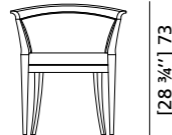

MISURE: L 68 P 55 H 73 HS 45
DESCRIZIONE: poltroncina in legno di ciliegio con schienale sagomato, seduta e schienale imbottiti. Finitura: F32/C Tessuto occorrente: cm 200x140 Design Centro Ricerche
PESO: 14 kg - m³: 0,3 - **COLLI:** 1

MEASURES: L 68 W 55 H 73 HS 45
DESCRIPTION: armchair made of cherry wood with round back, upholstered seat and back. Finish: F32/C Required fabric: 200x140 cm. Design by Centro Ricerche
WEIGHT: 14 kg - m³: 0,3 - **PIECES:** 1

ART. 5193/F
SEDIA MALIBÙ

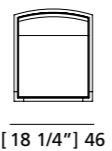
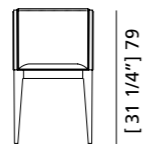

MISURE: L 46 P 54 H 79 HS 45
DESCRIZIONE: sedia in legno di frassino con seduta e schienale imbottiti. Schienale rivestito sul retro con particolare maniglia intagliata nel legno. Tessuto occorrente: cm 120x140. Design Centro Ricerche
PESO: 9 kg - m³: 0,17 - **COLLI:** 1

MEASURES: L 46 W 54 H 79 HS 45
DESCRIPTION: chair made of ash wood with upholstered seat and back. Special handle carved in the wood on the upholstered back. Required fabric: 120x140 cm. Design by centro Ricerche
WEIGHT: 9 kg - m³: 0,17 - **PIECES:** 1

ART. 5182
SEDIA ZERO IMPILABILE

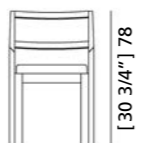

MISURE: L 49 P 53 H 78 HS 48
DESCRIZIONE: sedia in legno di ciliegio con seduta imbottita e struttura impilabile. Tessuto occorrente: cm 70x140. Finitura: F30. Design Centro Ricerche
PESO: 10 kg - m³: 0,16 - **COLLI:** 1

MEASURES: L 49 W 53 H 78 HS 48
DESCRIPTION: stackable chair made of cherry wood with upholstered seat. Required fabric: 70x140 cm. Finishing: F30. Design Centro Ricerche
WEIGHT: 10 kg - m³: 0,16 - **PIECES:** 1

ART. 5173
SEDIA IMPERIA



MISURE: L 43 P 52 H 87 HS 48
DESCRIZIONE: sedia in legno massello di ciliegio con schienale sagomato e seduta imbottita. Su richiesta in legno di noce canaletto. Tessuto occorrente: cm 70x140. Finitura: F60 Design Centro Ricerche
PESO: 8 kg - m³: 0,17 - **COLLI:** 1 sedia

MEASURES: L 43 W 52 H 87 HS 48
DESCRIPTION: chair made of cherry wood with shaped backrest and upholstered seat. Upon request made of walnut wood. Required fabric: 70x140 cm. Finishing: F60 Design Centro Ricerche
WEIGHT: 8 kg - m³: 0,17 - **PIECES:** 1 chairs

ART. 3868
POLTRONCINA IMPERIA

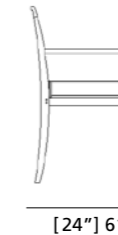
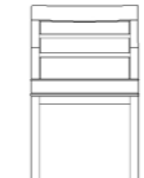

MISURE: L 53 P 61 H 87 HS 48
DESCRIZIONE: poltroncina in legno massello di ciliegio con schienale sagomato e seduta imbottita. Su richiesta in legno di noce canaletto. Tessuto occorrente: cm 80x140. Finitura: F60 Design Centro Ricerche
PESO: 11 kg - m³: 0,3 - **COLLI:** 1

MEASURES: L 53 W 61 H 87 HS 48
DESCRIPTION: armchair made of cherry wood with shaped backrest and upholstered seat. Upon request made of walnut wood. Required fabric: 80x140 cm. Finishing: F60 Design by centro Ricerche
WEIGHT: 11 kg - m³: 0,3 - **PIECES:** 1

ART. 5191
SEDIA PRISCILLA

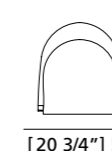
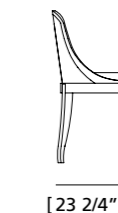
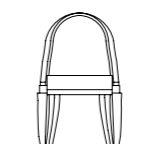

MISURE: L 53 P 60 H 89 HS 47
DESCRIZIONE: sedia in legno di ciliegio con gambe sagomate e schienale imbottito con struttura curvata ad elica. Tessuto occorrente: cm 150x140. Finitura: F100 Design Centro Ricerche
PESO: 12 kg - m³: 0,25 - **COLLI:** 1

MEASURES: L 53 W 60 H 89 HS 47
DESCRIPTION: chair made of cherry wood with shaped legs and upholstered back with helical curved structure. Required fabric: 150x140 cm. Finishing: F100 Design by centro Ricerche
WEIGHT: 12 kg - m³: 0,25 - **PIECES:** 1

ART. 5110
SEDIA DIANA

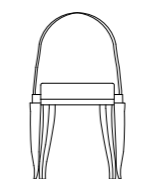

MISURE: L 53 P 60 H 89 HS 47
DESCRIZIONE: Sedia imbottita con struttura in legno massello di ciliegio. Tessuto occorrente 200x140 cm Finitura: F100 Design Centro Ricerche
PESO: 12 kg - m³: 0,25 - **COLLI:** 1

MEASURES: L 53 W 60 H 89 HS 47
DESCRIPTION: Chair made of solid cherry wood. Required fabrics 200x140 cm Finishing: F100 Design by centro Ricerche
WEIGHT: 12 kg - m³: 0,25 - **PIECES:** 1

ART. 5187
SEDIA MUSA

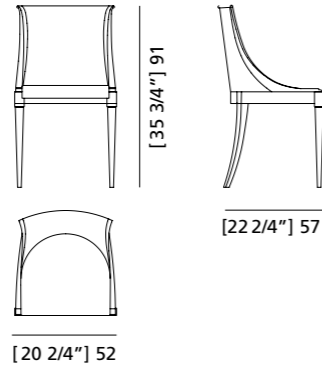

MISURE: L 52 P 57 H 91 HS 50
DESCRIZIONE: sedia in legno di ciliegio con gambe sagomate e schienale curvato imbottito. Seduta imbottita. Tessuto occorrente: cm 150x140. Finitura: F100. Design Centro Ricerche
PESO: 10 kg - m³: 0,18 - **COLLI:** 1

MEASURES: L 52 W 57 H 91 HS 50
DESCRIPTION: chair made of cherry wood with shaped legs and curved upholstered backrest. Upholstered seat. Required fabric: 150x140 cm. Finishing: F100. Design by centro Ricerche
WEIGHT: 10 kg - m³: 0,18 - **PIECES:** 1

ART. 3804
POLTRONCINA PRESIDENT

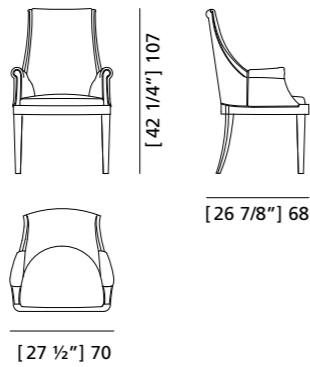

MISURE: L 70 P 68 H 107 HS 50
DESCRIZIONE: Poltroncina imbottita con braccioli in legno di ciliegio. Design Centro Ricerche
PESO: 25 kg - m³: 0,7 - **COLLI:** 1

MEASURES: L 70 W 68 H 107 HS 50
DESCRIPTION: Upholstered armchair made of cherry wood. Design by centro Ricerche
WEIGHT: 25 kg - m³: 0,7 - **PIECES:** 1

ART. 5154
SEDIA FLORA

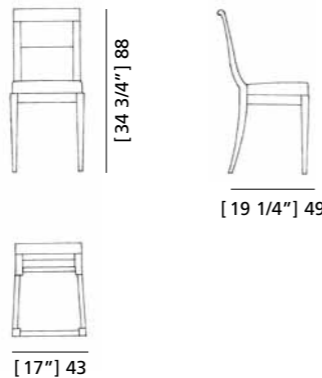

MISURE: L 43 P 49 H 88 HS 48
DESCRIZIONE: sedia in legno di ciliegio con schienale in legno sagomato. Seduta imbottita. Tessuto occorrente: cm 70x140. Finitura: F60
MISURE SEDUTA: L 43 P 40 H 50
PESO: 8 kg - m³: 0,17 - **COLLI:** 1

MEASURES: L 43 W 49 H 88 HS 48
DESCRIPTION: chair made of cherry wood with shaped backrest. Upholstered seat. Required fabric: 70x140 cm. Finishing: F60
SIZE SEAT: L 43 W 40 H 50
WEIGHT: 8 kg - m³: 0,17
PIECES: 1

ART. 5186
SEDIA VESTA

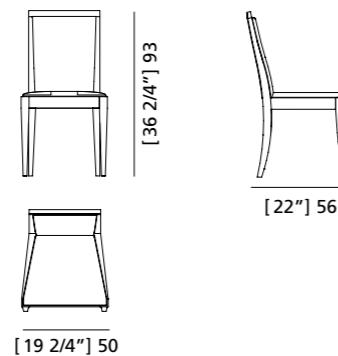

MISURE: L 50 P 56 H 93 HS 47
DESCRIZIONE: sedia in legno di ciliegio con seduta e schienale sagomato imbottiti, schienale imbottito anche sul retro. Su richiesta in legno di noce canaletto. Tessuto occorrente: cm 120x140. Finitura: F60
Design Centro Ricerche
PESO: 9 kg - m³: 0,17 - **COLLI:** 1

MEASURES: L 50 W 56 H 93 HS 47
DESCRIPTION: chair made of cherry wood with upholstered seat and shaped back. Upon request made of walnut wood. Required fabric: 120x140 cm. Finishing: F60
Design by centro Ricerche
WEIGHT: 9 kg - m³: 0,17 - **PIECES:** 1

ART. 5187
SEDIA MUSA CAPITONNÉ

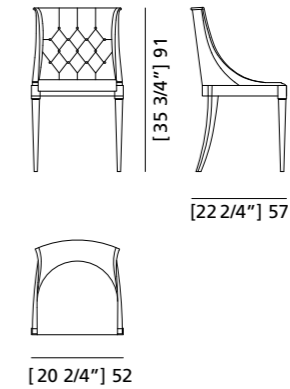

MISURE: L 52 P 57 H 91 HS 50
DESCRIZIONE: sedia in legno di ciliegio con gambe sagomate e schienale curvato imbottito. Seduta imbottita. Su richiesta in legno di noce canaletto. Tessuto occorrente: cm 150x140. Finitura: F100. Design Centro Ricerche
PESO: 10 kg - m³: 0,18 - **COLLI:** 1

MEASURES: L 52 W 57 H 91 HS 50
DESCRIPTION: chair made of cherry wood with shaped legs and curved upholstered backrest. Upholstered seat. Upon request made of walnut wood. Required fabric: 150x140 cm. Finishing: F100. Design by centro Ricerche
WEIGHT: 10 kg - m³: 0,18 - **PIECES:** 1

ART. 5181
SEDIA CLARA

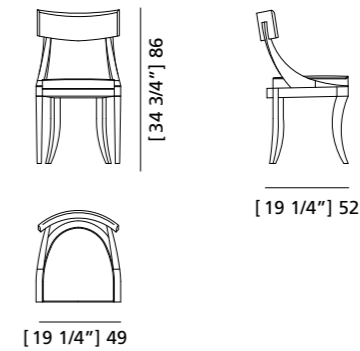

MISURE: L 49 P 52 H 86 HS 45
DESCRIZIONE: sedia in legno di ciliegio con gambe e schienale sagomati, seduta imbottita. Tessuto occorrente: cm 70x140. Finitura: F40
Design Centro Ricerche
MISURE SEDUTA: L 42 P 43 H 50
PESO: 10 kg - m³: 0,15 - **COLLI:** 1

MEASURES: L 49 W 52 H 86 HS 45
DESCRIPTION: chair made of cherry wood with shaped legs and back, upholstered seat. Required fabric: 70x140 cm. Finishing: F40
SIZE SEAT: L 42 W 43 H 50
Design by centro Ricerche
WEIGHT: 10 kg - m³: 0,15 - **PIECES:** 1

ART. 3801/F
POLTRONCINA AGATHA CON RUOTE



[48 1/4"] 122



[32 1/4"] 82



[30 3/4"] 78,5

MISURE: L 78,5 P 82 H 122
DESCRIZIONE: poltroncina girevole con ruote, struttura in legno di frassino sagomato e piede in metallo. Seduta e schienale imbottiti. Poltrona reclinabile, presenta ammortizzatore regolabile in altezza. Design Libero Rutilo
PESO: 30 kg - M3: 0,8 - COLLI: 1

MEASURES: L 78,5 W 82 H 122
DESCRIPTION: swivel armchair with wheels with turned ash wood structure and metal foot. Upholstered seat and backrest. Adjustable in height and reclining shock absorber. Design by Libero Rutilo
WEIGHT: 30 kg. M3: 0,8 - PIECES: 1

ART. 3810/F
POLTRONCINA BELLAGIO CON RUOTE



[36 3/4"] 93,5



[24 3/4"] 63

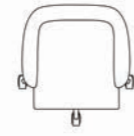

[24 3/4"] 63

MISURE: L 63 P 63 H 93,5 HS 54/64
DESCRIZIONE: Poltroncina in legno di frassino con braccioli e seduta imbottita. Base in acciaio con ammortizzatore regolabile in altezza. Design Libero Rutilo.
PESO: 22 kg - m³: 0,4 - COLLI: 1

MEASURES: L 63 W 63 H 93,5 HS 54/64
DESCRIPTION: Armchair in ash wood with armrest and upholstered seat. Steel base with height-adjustable shock absorber. Design by Libero Rutilo.
WEIGHT: 22 kg - m³: 0,4 - PIECES: 1

ART. 3888
POLTRONA BOSS

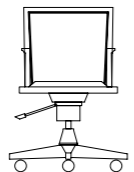

[40 1/4"] 102



[22 2/4"] 57

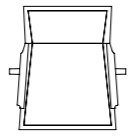

[21 2/4"] 55

MISURE: L 55 P 57 H 102 HS 42/52
DESCRIZIONE: poltroncina girevole con struttura in legno di ciliegio, ammortizzatore regolabile in altezza e reclinabile. Seduta e schienale imbottiti. Su richiesta in legno di noce canaletto. Tessuto occorrente: cm 140x140. Finitura: F32/C. Design Centro Ricerche MAMM
PESO: 23 kg - m³: 0,43 - COLLI: 1

MEASURES: L 55 W 57 H 102 HS 42/52
DESCRIPTION: swivel armchair on wheels made of cherry wood, shock absorber adjustable in height and reclining. Upholstered seat and back. Upon request made of walnut wood. Required fabric: 140x140 cm. Finishing: F32/C Design by centro Ricerche MAMM
WEIGHT: 23 kg - m³: 0,43 - PIECES: 1

ART. 5198/F
SEDIA GIREVOLE CARAMBOLA



[30 1/4"] 77



[23 2/4"] 60

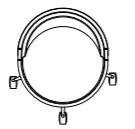

[20 2/4"] 52

MISURE: L 52 P 60 H 77 HS 48/58
DESCRIZIONE: Sedia in legno di frassino tinto con piede in metallo a posizione variabile e ruote girevoli. Tessuto occorrente: cm 150x140. Design Maurizio Duranti
PESO: 13 kg - m³: 0,20 - COLLI: 1

MEASURES: L 52 W 60 H 77 HS 48/58
DESCRIPTION: Swivel chair made of colored ash wood with metal adjustable leg and wheels. Required fabric: cm 150x140. Design by Maurizio Duranti
WEIGHT: 13 kg - m³: 0,20 - PIECES: 1

ART. 5189
SEDIA PRESIDENT

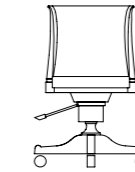

[36 2/4"] 93

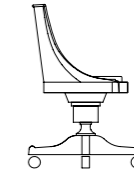

[25 2/4"] 65

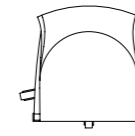

[21 1/4"] 54

MISURE: L 54 P 65 H 93 HS 48/58
DESCRIZIONE: sedia girevole in legno di ciliegio con ammortizzatore regolabile in altezza e reclinabile. Seduta e schienale imbottiti. Su richiesta in legno di noce canaletto. Tessuto occorrente: cm 150x140. Finitura: F30 Design Centro Ricerche MAMM
PESO: 22 kg - m³: 0,4 - COLLI: 1

MEASURES: L 54 W 65 H 93 HS 48/58
DESCRIPTION: swivel chair on wheels made of cherry wood, shock absorber adjustable in height and reclining. Upholstered seat and back. Upon request made of walnut wood. Required fabric: 150x140 cm. Finishing: F30 Design by centro Ricerche MAMM
WEIGHT: 22 kg - m³: 0,4 - PIECES: 1

ART. 3897
POLTRONA PRESIDENT

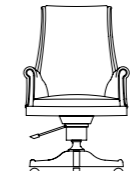

[42 1/4"] 107

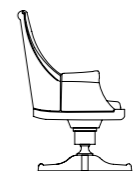

[27 2/4"] 75

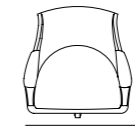

[27 2/4"] 70

MISURE: L 70 P 75 H 107 HS 48/58
DESCRIZIONE: poltrona girevole con struttura in legno di ciliegio, ammortizzatore regolabile in altezza e reclinabile. Seduta, braccioli e schienale imbottiti. Su richiesta in legno di noce canaletto. Tessuto occorrente: cm 220x140. Design Centro Ricerche MAMM
PESO: 30 kg - m³: 0,7 - COLLI: 1

MEASURES: L 70 W 75 H 107 HS 48/58
DESCRIPTION: swivel armchair on wheels made of cherry wood, shock absorber adjustable in height and reclining. Upholstered seat, back and armrests. Upon request made of walnut wood. Required fabric: 220x140 cm. Design by centro Ricerche MAMM
WEIGHT: 30 kg - m³: 0,7 - PIECES: 1

ART. 3897
POLTRONA PRESIDENT CAPITONNÉ

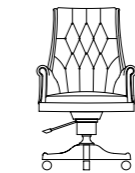

[42 1/4"] 107



[27 2/4"] 75

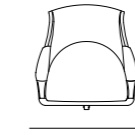

[27 2/4"] 70

MISURE: L 70 P 75 H 107 HS 48/58
DESCRIZIONE: poltrona girevole con struttura in legno di ciliegio, ammortizzatore regolabile in altezza e reclinabile. Seduta, braccioli e schienale imbottiti. Su richiesta in legno di noce canaletto. Tessuto occorrente: cm 220x140. Design Centro Ricerche MAMM
PESO: 30 kg - m³: 0,7 - COLLI: 1

MEASURES: L 70 W 75 H 107 HS 48/58
DESCRIPTION: swivel armchair on wheels made of cherry wood, shock absorber adjustable in height and reclining. Upholstered seat, back and armrests. Upon request made of walnut wood. Required fabric: 220x140 cm. Design by centro Ricerche MAMM
WEIGHT: 30 kg - m³: 0,7 - PIECES: 1

ART. 3808
POLTRONA PRESIDENT ACCIAIO

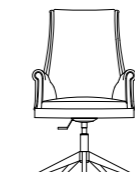

[42 1/4"] 107



[27 2/4"] 75

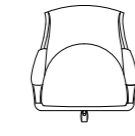

[27 2/4"] 70

MISURE: L 70 P 75 H 107 HS 48/58
DESCRIZIONE: Poltrona girevole imbottita con struttura in legno massello di ciliegio. Base in acciaio con ammortizzatore regolabile in altezza. Tessuto occorrente 220x140 cm Design Centro Ricerche MAMM
PESO: 30 kg - m³: 0,7 - COLLI: 1

MEASURES: L 70 W 75 H 107 HS 48/58
DESCRIPTION: Swivel armchair on wheels made of solid cherry wood. Steel base with shock absorber adjustable in height. Required fabrics 220x100 cm Design by centro Ricerche MAMM
WEIGHT: 30 kg - m³: 0,7 - PIECES: 1

ART. 3862
POLTRONA BIEDERMEIER

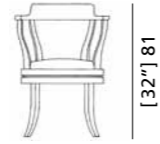

[32 1/4"] 81



[23 2/4"] 60



[25 1/4"] 64

MISURE: L 64 P 60 H 81 **HS 50/60**
DESCRIZIONE: poltrona in legno di ciliegio con braccioli e schienale sagomati, seduta girevole imbottita e gambe a sciabola. Tessuto occorrente: cm 100x140. Finitura: F60 Design Centro Ricerche MAMM
MISURE SEDUTA: L 43 P 50 H 50
PESO: 17 kg - m³: 0,39 - **COLLI:** 1

MEASURES: L 64 W 60 H 81 **HS 50/60**
DESCRIPTION: armchair made of cherry wood with armrests and shaped backrest, swivel upholstered seat and saber legs. Required fabric: 100x140 cm. Finishing: F60 Design by centro Ricerche MAMM
SIZE SEAT: L 43 W 50 H 50
WEIGHT: 17 kg - m³: 0,39 - **PIECES:** 1

ART. 5268/F
SEDIA SCALA

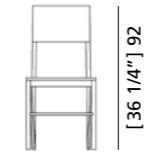

[36 1/4"] 92



[17"] 43



[17 1/4"] 44

MISURE: L 44 P 43 H 92
DESCRIZIONE: sedia in legno massello di frassino, trasformabile in scala con chiusura a calamita. Su richiesta in legno di noce canaletto. Finitura: F32 Design Centro Ricerche MAMM
PESO: 12 kg - m³: 0,26
COLLI: 1

MEASURES: L 44 W 43 H 92
DESCRIPTION: chair made of solid ash, convertible into a stepladder with magnetic closure. Upon request made of walnut wood. Finishing: F32 Design by centro Ricerche MAMM
WEIGHT: 12 kg - m³: 0,26
PIECES: 1

ART. 3883
POLTRONA BIEDERMEIER GIREVOLE CON RUOTE

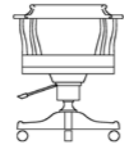

[31 2/4"] 80



[23 2/4"] 60



[25 1/4"] 64

MISURE: L 64 P 60 H 80 **HS 46/56**
DESCRIZIONE: poltrona girevole in legno di ciliegio con braccioli e schienale sagomati, ammortizzatore regolabile in altezza e reclinabile con seduta imbottita. Tessuto occorrente: cm 100x140. Finitura: F60 Design Centro Ricerche MAMM
PESO: 21 kg - m³: 0,39 - **COLLI:** 1

MEASURES: L 64 W 60 H 80 **HS 46/56**
DESCRIPTION: armchair on wheels made of cherry wood with armrests and shaped backrest, swivel upholstered seat. Shock absorber adjustable in height and reclining. Required fabric: 100x140 cm. Finishing: F60 Design by centro Ricerche MAMM
WEIGHT: 21 kg - m³: 0,39 - **PIECES:** 1

ART. 3848
POLTRONA DIRETTORIO
GIREVOLE



[35 2/4"] 90



[25 2/4"] 65



[25 1/4"] 64

MISURE: L 64 P 65 H 90 **HS 50/60**
DESCRIZIONE: poltrona in legno di ciliegio con braccioli e schienale sagomati, schienale e seduta girevole imbottiti. Tessuto occorrente: cm 120x140. Finitura: F60 Design Centro Ricerche MAMM
MISURE SEDUTA: L 43 P 50 H 50
PESO: 17 kg - m³: 0,43 - **COLLI:** 1

MEASURES: L 64 W 65 H 90 **HS 50/60**
DESCRIPTION: armchair made of cherry wood with armrests and upholstered backrest, swivel upholstered seat and saber legs. Required fabric: 120x140 cm. Finishing: F60. Design by centro Ricerche MAMM
SIZE SEAT: L 43 W 50 H 50
WEIGHT: 17 kg - m³: 0,43 - **PIECES:** 1

ART. 3882
POLTRONA DIRETTORIO
GIREVOLE CON RUOTE



[32 1/4"] 82



[27 1/4"] 69



[25 1/4"] 64

MISURE: L 64 P 69 H 82 **HS 46/56**
DESCRIZIONE: poltrona girevole in legno di ciliegio con braccioli e schienale sagomati, ammortizzatore regolabile in altezza e reclinabile con seduta e schienale imbottiti. Tessuto occorrente: cm 120x140. Finitura: F60 Design Centro Ricerche MAMM
PESO: 23 kg - m³: 0,30 - **COLLI:** 1

MEASURES: L 64 W 69 H 82 **HS 46/56**
DESCRIPTION: armchair on wheels made of cherry wood with armrests and upholstered backrest, swivel upholstered seat. Shock absorber adjustable in height and reclining. Required fabric: 120x140 cm. Finishing: F60 Design by centro Ricerche MAMM
WEIGHT: 23 kg - m³: 0,30 - **PIECES:** 1

ART. 5327
SGABELLO DAPHNE

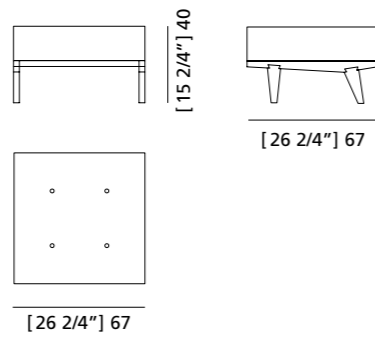

MISURE: L 67 P 67 H 40
DESCRIZIONE: sgabello - Pouf con struttura in legno massello di ciliegio e cuscino imbottito removibile. Da abbinare a poltrona Dafne art. 3887, 3896. Finitura: F32/C. Tessuto occorrente: cm 100x140 Design Centro Ricerche MAMM PESO: 5 kg - m³: 0,25 - COLLI: 1

MEASURES: L 67 W 67 H 40
DESCRIPTION: ottoman made of cherry wood and removable upholstered cushion. To be combined with Dafne armchair art. 3887, 3896. Finishing: F32/C Required fabric: cm 100x140 Design by centro Ricerche MAMM WEIGHT: 5 kg - m³: 0,25 - PIECES: 1

ART. 5337/F
SGABELLO COOPER

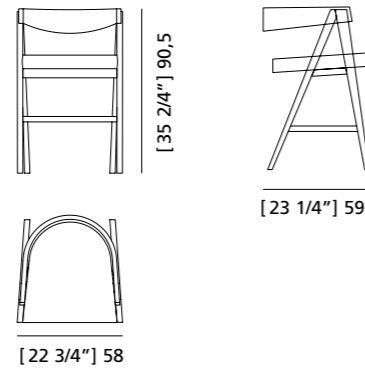

MISURE: L 58 P 59 H 90,5 HS 63
DESCRIZIONE: Sgabello bar in legno di frassino, seduta imbottita e rivestita in tessuto. Finitura F32/F. Design by centro Ricerche MAMM PESO: 15 kg - m³: 0,40 - COLLI: 1

MEASURES: L 58 P 59 H 90,5 HS 63
DESCRIPTION: Bar stool in ash wood with upholstered seat. Finishing: F32/F. Design by centro Ricerche MAMM WEIGHT: 15 kg - m³: 0,40 - PIECES: 1

ART. 5338/F
SGABELLO BURTON

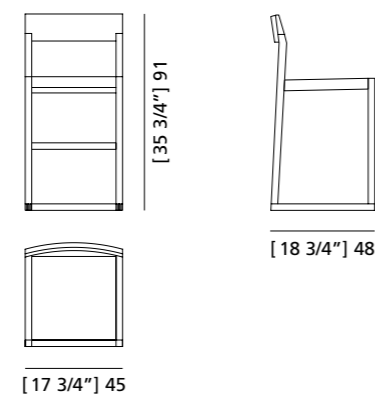

MISURE: L 45 P 48 H 91 HS 63
DESCRIZIONE: Sgabello bar in legno di ciliegio, seduta imbottita e rivestita in tessuto. Finitura F32/C. Design by centro Ricerche MAMM PESO: 15 kg - m³: 0,40 - COLLI: 1

MEASURES: L 45 P 48 H 91 HS 63
DESCRIPTION: Bar stool in ash wood with upholstered seat. Finishing: F32/C. Design by centro Ricerche MAMM WEIGHT: 15 kg - m³: 0,40 - PIECES: 1

ART. 5326
POUF MOENA

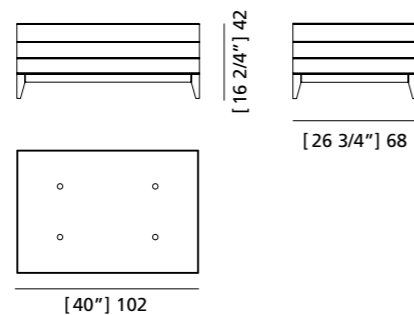

MISURE: L 102 P 68 H 42
DESCRIZIONE: Pouf imbottito con contenitore interno e struttura in legno di ciliegio. Disponibile con letto interno estraibile Tessuto occorrente: cm 400x140. Finitura: F150. Design Centro Ricerche MAMM PESO: 20 kg - m³: 0,35 - COLLI: 1

MEASURES: L 102 W 68 H 42
DESCRIPTION: Upholstered pouf made of cherry wood with case inside. Available with internal folding bed. Required fabric: 400x140 cm. Finishing: F150. Design by centro Ricerche MAMM WEIGHT: 20 kg - m³: 0,35 - PIECES: 1

ART. 5325/N
SGABELLO ZERO

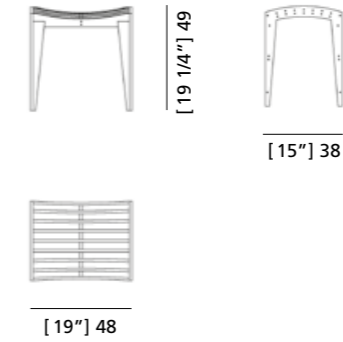

MISURE: L 48 P 38 H 49
DESCRIZIONE: sgabello in legno multistrato e impiallacciatura di noce canaletto con listelli assemblati ad incastro, senza punti metallici. Su richiesta cuscino in pelle o tessuto. Finitura: F32/N. Design Franco Poli. PESO: 7 kg - m³: 0,1 - COLLI: 1

MEASURES: L 48 W 38 H 49
DESCRIPTION: stool made of plywood with walnut veneer, assembled with wooden pins only. Finishing: F32/N. Design Franco Poli. WEIGHT: 7 kg - m³: 0,1 - PIECES: 1

ART. 5328
SGABELLO MANHATTAN

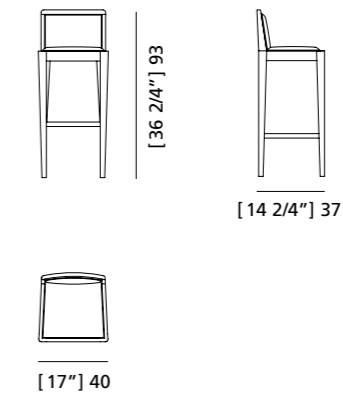

MISURE: L 40 P 37 H 93 HS 70
DESCRIZIONE: sgabello in legno di ciliegio con seduta e schienali imbottiti in pelle o tessuto. Su richiesta listello poggiatesta in acciaio. Finitura: F32/C. Tessuto occorrente: cm 50x140 Design Centro Ricerche MAMM MISURE SEDUTA: L 35 P 28 H 70 PESO: 10 kg - m³: 0,3 - COLLI: 1

MEASURES: L 40 W 37 H 93 HS 70
DESCRIPTION: stool made of cherry wood with upholstered seat and back, in leather or fabric. Upon request steel footrest. Finishing: F32/C Required fabric: cm 50x140 Design by centro Ricerche MAMM SIZE SEAT: L 35 W 28 H 70 WEIGHT: 10 kg - m³: 0,3 - PIECES: 1

ART. 5315/F
SGABELLO JOYCE

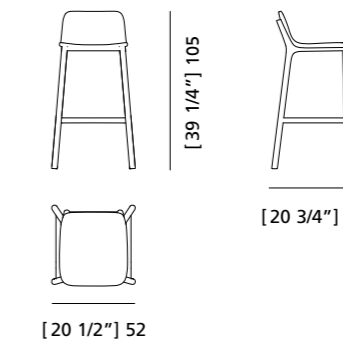

MISURE: L 52 P 53 H 105 HS 63, 72, 80
DESCRIZIONE: Sgabello bar in legno di frassino con seduta imbottita e puntali in ottone. Design Libero Rutilo. MISURE SEDUTA: L 35 P 28 H 78 PESO: 10 kg - m³: 0,4 - COLLI: 1

MEASURES: L 52 P 53 H 105 HS 63, 72, 80
DESCRIPTION: Bar stool made of turned ash wood with upholstered seat and brass tips. Design Libero Rutilo. SIZE SEAT: L 35 W 28 H 78 WEIGHT: 10 kg - m³: 0,4 - PIECES: 1

ART. 5304/F
SGABELLO ICARO

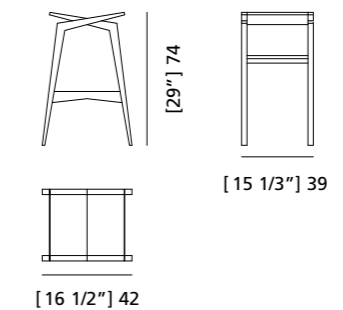

MISURE: L 42 P 39 H 74 HS 72
DESCRIZIONE: Sgabello in legno di frassino. Design Itamar Harari PESO: 10 kg - m³: 0,3 - COLLI: 1

MEASURES: L 42 P 39 H 74 HS 72
DESCRIPTION: Bar stool made of ash wood. Design by Itamar Harari WEIGHT: 10 kg - m³: 0,3 - PIECES: 1

ART. 5303/F
SGABELLO ICARO

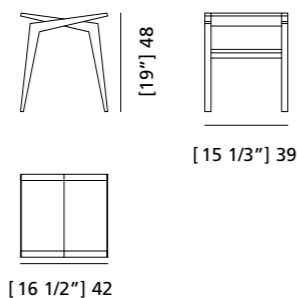

MISURE: L 42 P 39 H 48
DESCRIZIONE: Sgabello basso in legno di frassino.
Design Itamar Harari
PESO: 7 kg - m³: 0,1
COLLI: 1

MEASURES: L 42 P 39 H 48
DESCRIPTION: Low stool made of ash wood.
Design by Itamar Harari
WEIGHT: 7 kg - m³: 0,1
PIECES: 1

ART. 5332/F
SGABELLO JENNY

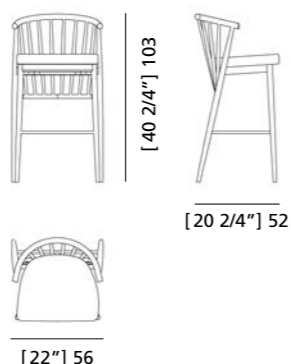

MISURE: L 56 P 52 H 103 HS 74
DESCRIZIONE: Sgabello bar in legno di frassino con seduta imbottita.
Design Libero Rutilo
PESO: 15 kg - m³: 0,35
COLLI: 1

MEASURES: L 56 P 52 H 103 HS 74
DESCRIPTION: Bar stool made of ash wood with upholstered seat.
Design by Libero Rutilo
WEIGHT: 15 kg - m³: 0,35
PIECES: 1

ART. 5333/F
SGABELLO BAR BELLAGIO

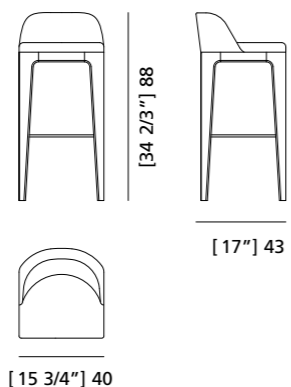

MISURE: L 40 P 43 H 88 HS 63, 72
DESCRIZIONE: Sgabello bar in legno di frassino con seduta imbottita.
Design Libero Rutilo
PESO: 15 kg - m³: 0,4
COLLI: 1

MEASURES: L 40 P 43 H 88 HS 63, 72
DESCRIPTION: Bar stool made of ash wood with upholstered seat.
Design by Libero Rutilo
WEIGHT: 15 kg - m³: 0,4
PIECES: 1

ART. 5336
SGABELLO BAR MUSA

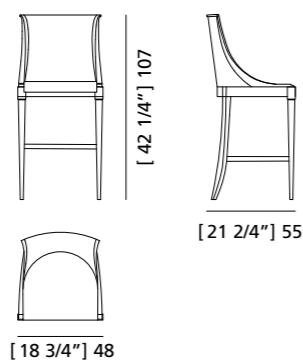

MISURE: L 48 P 55 H 107 HS 70
DESCRIZIONE: Sgabello bar con seduta e schienale imbottiti.
Design Centro Ricerche MAMM
PESO: 20 kg - m³: 0,4
COLLI: 1

MEASURES: L 48 P 55 H 107 HS 70
DESCRIPTION: Bar stool with upholstered seat and backrest.
Design by centro Ricerche MAMM
WEIGHT: 20 kg - m³: 0,4
PIECES: 1

ART. 5331
SGABELLO BAR

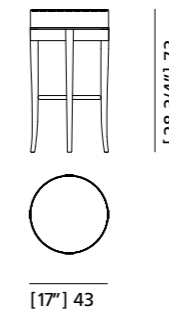

MISURE: diam. 43 H 73
DESCRIZIONE: sgabello in legno di ciliegio sagomato con seduta imbottita e profilo tubolare in ottone poggiapiedi.
Tessuto occorrente: cm 50x140.
Finitura: F60
Design Centro Ricerche MAMM
PESO: 6 kg - m³: 0,15 - COLLI: 1

MEASURES: diam. 43 H 73
DESCRIPTION: stool made of cherry wood with upholstered seat and contoured profile, tubular brass footrest.
Required fabric: cm 50x140.
Finishing: F60.
Design by centro Ricerche MAMM
WEIGHT: 6 kg - m³: 0,15 - PIECES: 1

ART. 5312
SGABELLO BIEDERMEIER

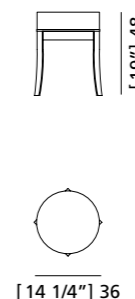

MISURE: diam. 36 H 48
DESCRIZIONE: sgabello in legno di ciliegio sagomato con seduta imbottita.
Tessuto occorrente: cm 50x140.
Finitura: F60
Design Centro Ricerche MAMM
PESO: 6 kg - m³: 0,1
COLLI: 1

MEASURES: diam. 36 H 48
DESCRIPTION: stool made of cherry wood with shaped upholstered seat.
Required fabric: 50x140 cm. Finishing: F60
Design by centro Ricerche MAMM
WEIGHT: 6 kg - m³: 0,1
PIECES: 1

ART. 5311
SGABELLO BIEDERMEIER

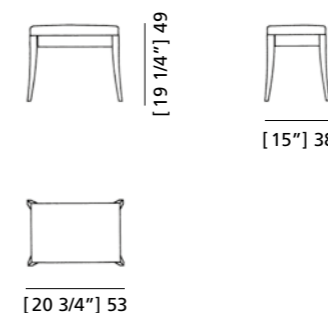

MISURE: L 53 P 38 H 49
DESCRIZIONE: sgabello in legno di ciliegio sagomato con seduta imbottita.
Tessuto occorrente: cm 65x140.
Finitura: F60
Design Centro Ricerche MAMM
PESO: 7 kg - m³: 0,16
COLLI: 1

MEASURES: L 53 W 38 H 49
DESCRIPTION: stool made of cherry wood with upholstered seat and shaped legs.
Required fabric: 65x140 cm. Finishing: F60
Design by centro Ricerche MAMM
WEIGHT: 7 kg - m³: 0,16
PIECES: 1

ART. 5310
SGABELLO DIRETTORIO

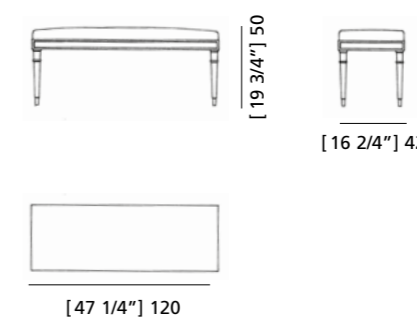

MISURE: L 120 P 42 H 50
DESCRIZIONE: panca in legno di ciliegio intagliato con seduta imbottita. Tessuto occorrente: cm 105x140. Finitura: F60
Design Centro Ricerche MAMM
PESO: 15 kg - m³: 0,3
COLLI: 1

MEASURES: L 120 W 42 H 50
DESCRIPTION: bench made of carved cherry wood with upholstered seat.
Required fabric: 105x140 cm. Finishing: F60
Design by centro Ricerche MAMM
WEIGHT: 15 kg - m³: 0,3
PIECES: 1

ART. 5334/F
PANCA BELLAGIO

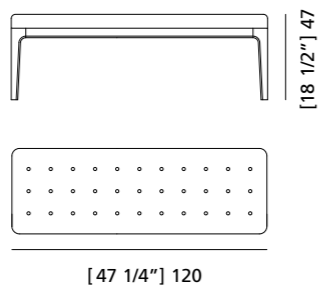

[18 1/2"] 47

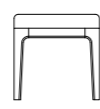

[15 3/4"] 40

MISURE: L 120 P 40 H 47
DESCRIZIONE: Panca imbottita in legno di frassino.
Design Libero Rutilo
PESO: 10 kg - m³: 0,3 - **COLLI:** 1

MEASURES: L 120 P 40 H 47
DESCRIPTION: Upholstered bench made of ash wood.
Design by Libero Rutilo
WEIGHT: 10 kg - m³: 0,3 - **PIECES:** 1

ART. 5335
POUFF CAPITONNÉ

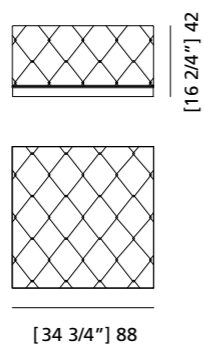

[16 2/4"] 42

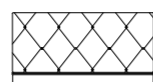

[34 3/4"] 88

MISURE: L 88 P 88 H 42
DESCRIZIONE: Pouf con base in legno e ottone, rivestimento capitonné.
Design Centro Ricerche MAM
PESO: 40 kg - m³: 0,4
COLLI: 1

MEASURES: L 88 P 88 H 42
DESCRIPTION: Pouf with brass base and capitonné upholstery.
Design by centro Ricerche MAM
WEIGHT: 40 kg - m³: 0,4
PIECES: 1

COMPLEMENTI
TAVOLINI
SPECCHI

ACCESSORIES
COFFEE TABLES
MIRRORS



ART. 5621/F
TAVOLINO LAYERS

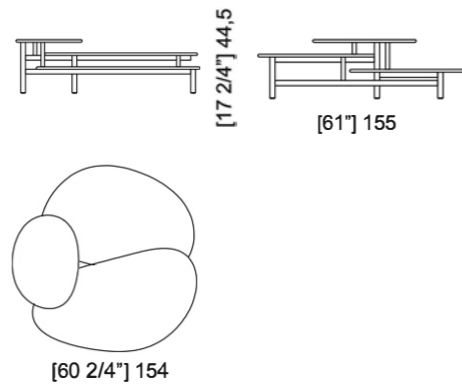

MISURE: L 154 P 155 H 44,5
DESCRIZIONE: tavolino in legno di frassino formato da un basamento, in legno tornito, e 3 piani di differenti dimensioni posizionati ad altezze diverse.
Design Libero Rutilo
PESO: 40 kg. - m³: 1
COLLI: 1

MEASURES: L 154 W 155 H 44,5
DESCRIPTION: ash wood table formed by a base, in turned wood, and 3 tops of different sizes positioned at different heights. Design by Libero Rutilo
WEIGHT: 40 kg. - m³: 1
PIECES: 1

ART. 5615/P
TAVOLINO FRANK

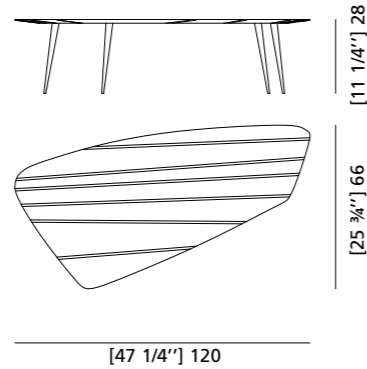

MISURE: L 120 P 66 H 28
DESCRIZIONE: realizzato in legno di palissandro, nella superficie presenta intarsi in legno di acero che si trasformano in naturali decori del piano. Può essere accoppiato al tavolino Gene ART. 5616/A. Finitura: F32
Design Itamar Harari
PESO: 10 kg - m³: 0,25 - COLLI: 1

MEASURES: L 120 W 66 H 28
DESCRIPTION: made of rosewood, the top has a maple wood inlay forming a natural decoration. It can be matched with Gene table ART. 5616/A. Finishing: F32
Design: Itamar Harari
WEIGHT: 10 kg - m³: 0,25 - PIECES: 1

ART. 5616/A
TAVOLINO GENE

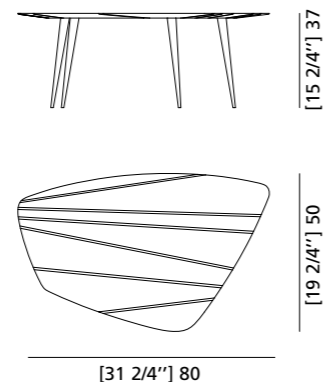

MISURE: L 80 P 50 H 37
DESCRIZIONE: : realizzato in legno di acero per la struttura e wengè per gli intarsi del piano. Può essere accoppiato al tavolino Frank ART. 5615/P. Finitura: F32
Design Itamar Harari
PESO: 6 kg - m³: 0,15
COLLI: 1

MEASURES: L 80 W 50 H 37
DESCRIPTION: made of maple wood for the structure and wengè inlay for the top. It can be matched with Frank table ART. 5615/P. Finishing: F32
Design: Itamar Harari
WEIGHT: 6 kg - m³: 0,15
PIECES: 1

ART. 5620/F
TAVOLINO TRIFOGLIO

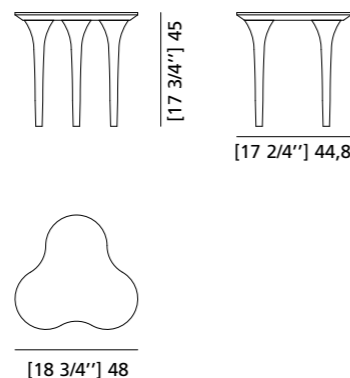

MISURE: L 48 P 44,8 H 45
DESCRIZIONE: tavolino realizzato in legno di frassino massello con gambe tornite. Finitura: F32
Design Massimiliano Caviaasca
PESO: 5 kg - m³: 0,10
COLLI: 1

MEASURES: L 48 W 44,8 H 45
DESCRIPTION: table made of solid ash with turned legs. Finishing: F32.
Design: Massimiliano Caviaasca
WEIGHT: 5 kg - m³: 0,10
PIECES: 1

ART. 5611/B
TAVOLINO CINO ALTO
ART. 5612/B TAVOLINO CINO BASSO L 37,5 P 37,5 H 46

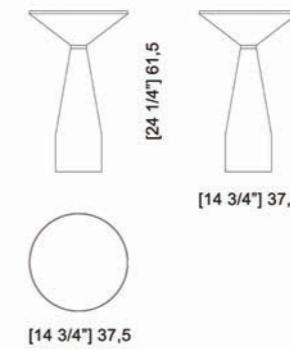

MISURE: L 37,5 P 37,5 H 61,5
DESCRIZIONE: tavolino con piano tornito in legno di frassino e basamento in marmo bianco di Carrara. Il piano e il basamento sono uniti da un anello in ottone.
Design Libero Rutilo
PESO: 25 kg. - m³: 1
COLLI: 1

MEASURES: L 37,5 W 37,5 H 61,5
DESCRIPTION: Small table in turned ash wood and white Carrara marble base. The top and the base are united by a brass ring. Design by Libero Rutilo.
WEIGHT: 25 kg. - m³: 1
PIECES: 1

ART. 5611/V
TAVOLINO CINO ALTO
ART. 5612/V TAVOLINO CINO BASSO L 37,5 P 37,5 H 46

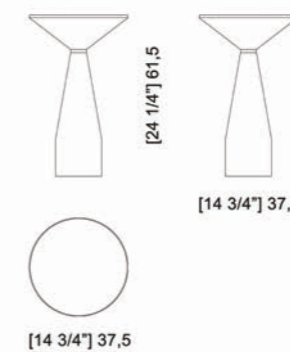

MISURE: L 37,5 P 37,5 H 61,5
DESCRIZIONE: tavolino con piano tornito in legno di frassino e basamento in marmo verde del Guatemala. Il piano e il basamento sono uniti da un anello in ottone. Design Libero Rutilo
PESO: 25 kg. - m³: 1
COLLI: 1

MEASURES: L 37,5 W 37,5 H 61,5
DESCRIPTION: Small table in turned ash wood and green Guatemala marble base. The top and the base are united by a brass ring. Design by Libero Rutilo.
WEIGHT: 25 kg. - m³: 1
PIECES: 1

ART. 5611/R
TAVOLINO CINO ALTO
ART. 5612/R TAVOLINO CINO BASSO L 37,5 P 37,5 H 46

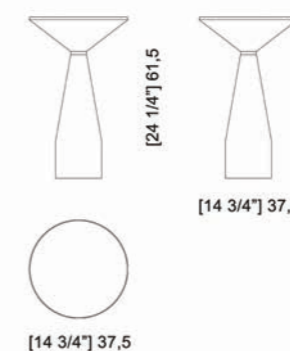

MISURE: L 37,5 P 37,5 H 61,5
DESCRIZIONE: tavolino con piano tornito in legno di frassino e basamento in marmo rosso di Levanto. Il piano e il basamento sono uniti da un anello in ottone. Design Libero Rutilo
PESO: 25 kg. - m³: 1
COLLI: 1

MEASURES: L 37,5 W 37,5 H 61,5
DESCRIPTION: Small table in turned ash wood and red Levanto marble base. The top and the base are united by a brass ring. Design by Libero Rutilo.
WEIGHT: 25 kg. - m³: 1
PIECES: 1

ART. 5611/G
TAVOLINO CINO ALTO
ART. 5612/G TAVOLINO CINO BASSO L 37,5 P 37,5 H 46

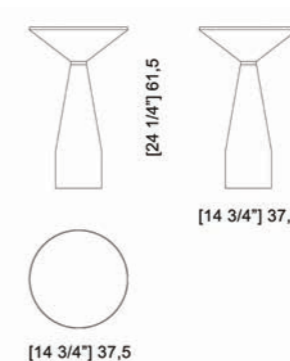

MISURE: L 37,5 P 37,5 H 61,5
DESCRIZIONE: tavolino con piano tornito in legno di frassino e basamento in marmo giallo reale. Il piano e il basamento sono uniti da un anello in ottone. Design Libero Rutilo
PESO: 25 kg. - m³: 1
COLLI: 1

MEASURES: L 37,5 W 37,5 H 61,5
DESCRIPTION: Small table in turned ash wood and royal yellow marble base. The top and the base are united by a brass ring. Design by Libero Rutilo.
WEIGHT: 25 kg. - m³: 1
PIECES: 1

ART. 5610
TAVOLINO CARAMBOLA

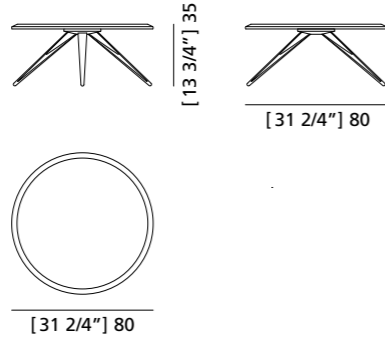

MISURE: diam. 80 H 35
DESCRIZIONE: Grande tavolino da salotto con piano in cristallo nero, gambe in legno di ciliegio, wengè e acero a forma di stecche da biliardo. Finitura: F32.
 Design by centro Ricerche MAMM
PESO: 12 kg - m³: 0,25 - **COLLI:** 1

MEASURES: diam. 80 H 35
DESCRIPTION: Large coffee table with black glass top, legs made of cherry, wengè and maple wood in billiard cue shape. Finishing: F32
 Design by centro Ricerche MAMM
WEIGHT: 12 kg - m³: 0,25 - **PIECES:** 1

ART. 5626/F
TAVOLINO BELLAGIO

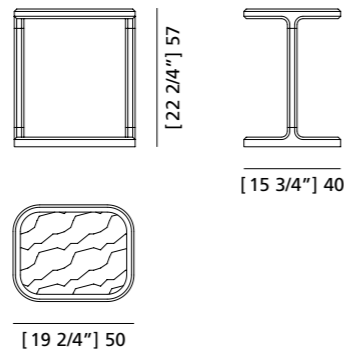

MISURE: L 50 P 40 H 57
DESCRIZIONE: Tavolino in legno di frassino sagomato, piano in **pietra** o legno. Finitura F160.
 Design Libero Rutilo
PESO: 8 kg - m³: 0,11 - **COLLI:** 1

MEASURES: L 50 P 40 H 57
DESCRIPTION: Coffee table made of ash wood with marble or wooden top. Finishing: F160.
 Design Libero Rutilo
WEIGHT: 8 kg - m³: 0,11 - **PIECES:** 1

ART. 5627/F
TAVOLINO BELLAGIO

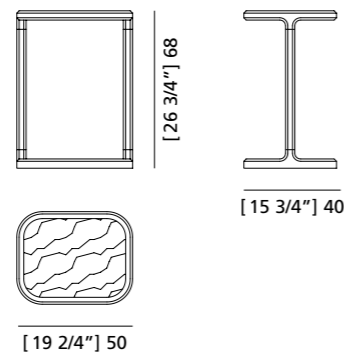

MISURE: L 50 P 40 H 68
DESCRIZIONE: Tavolino in legno di frassino sagomato, piano in **pietra** o legno. Finitura F32/F.
 Design Libero Rutilo
PESO: 9 kg - m³: 0,13 - **COLLI:** 1

MEASURES: L 50 P 40 H 68
DESCRIPTION: Coffee table made of ash wood with marble or wooden top. Finishing: F32/F.
 Design Libero Rutilo
WEIGHT: 9 kg - m³: 0,13 - **PIECES:** 1

ART. 5628/F
TAVOLINO BELLAGIO

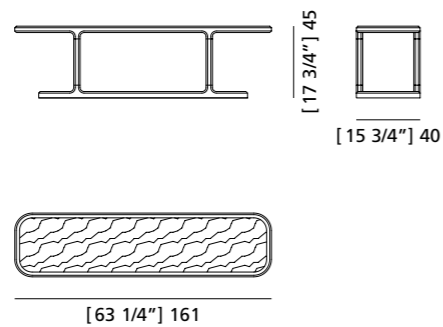

MISURE: L 161 P 40 H 45
DESCRIZIONE: Tavolino in legno di frassino sagomato, piano in **pietra** o legno. Finitura F32/F.
 Design Libero Rutilo
PESO: 20 kg - m³: 0,30 - **COLLI:** 1

MEASURES: L 161 P 40 H 45
DESCRIPTION: Low table made of ash wood with marble or wooden top. Finishing: F32/F.
 Design Libero Rutilo
WEIGHT: 20 kg - m³: 0,30 - **PIECES:** 1

ART. 5607
TAVOLINO CARAMBOLA

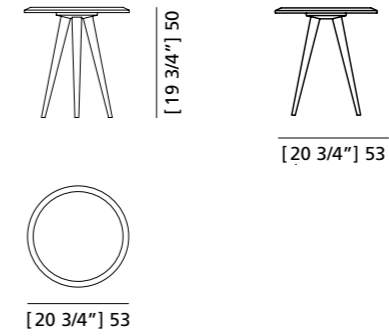

MISURE: Diam 53 H 50
DESCRIZIONE: tavolino in legno di frassino tinto ebano con piano colorato. Gambe tornite con legno di ciliegio, wengè e acero a forma di stecche da biliardo.
 Finiture: gambe F32, piano FL130.
 Design Maurizio Duranti
PESO: 10 kg - m³: 0,15 - **COLLI:** 1

MEASURES: Diam 53 H 50
DESCRIPTION: side table made of ash wood with ebony finishing and colored top. Turned legs in the shape of pool cues made of cherry, maple and wengè woods. Finishing: F140, F32.
 Design by Maurizio Duranti
WEIGHT: 10 kg - m³: 0,15 - **PIECES:** 1

ART. 5730/F
TAVOLO GIOCO CARAMBOLA

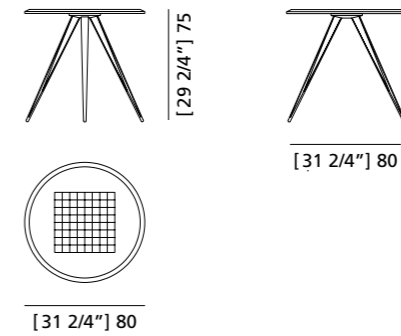

MISURE: Diam 80 H 75
DESCRIZIONE: tavolo in legno di frassino tinto ebano con piano colorato. Gambe tornite con legno di ciliegio, wengè e acero a forma di stecche da biliardo.
 Finiture: gambe F32, piano FL130.
 Design Maurizio Duranti
PESO: 10 kg - m³: 0,15 - **COLLI:** 1

MEASURES: Diam 80 H 75
DESCRIPTION: table made of ash wood with ebony finishing and colored top. Turned legs in the shape of pool cues made of cherry, maple and wengè woods. Finishing: F140, F32.
 Design by Maurizio Duranti
WEIGHT: 10 kg - m³: 0,15 - **PIECES:** 1

ART. 5606
TAVOLINO BOOK

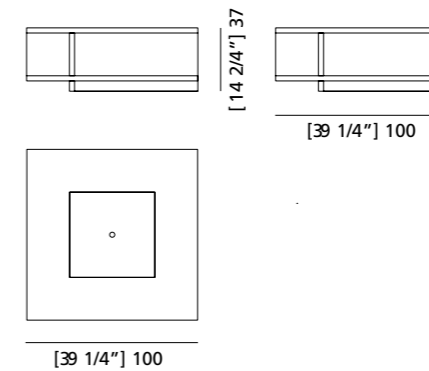

MISURE: L 100 P 100 H 37
DESCRIZIONE: tavolino - libreria in legno di ciliegio con ampio vano interno colorato, chiuso da un vassoio estraibile.
 Finiture: esterno F32/C, interno FL100
 Design Centro Ricerche MAMM
PESO: 55 kg - m³: 0,44 - **COLLI:** 1

MEASURES: L 100 W 100 H 37
DESCRIPTION: coffee table made of cherry wood to be used as a bookcase. Internal compartment closed by a removable tray. Finishing: F32/C, FL100.
 Design by centro Ricerche MAMM
WEIGHT: 55 kg - m³: 0,44 - **PIECES:** 1

ART. 5604
TAVOLINO PATCHWORK

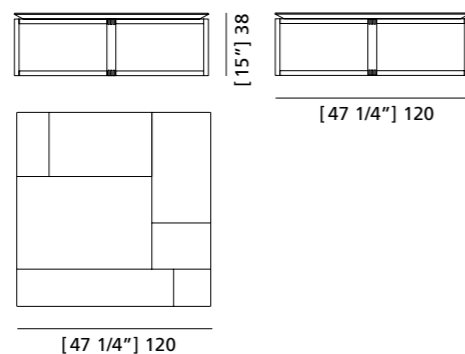

MISURE: L 120 P 120 H 38
DESCRIZIONE: tavolino quadrato in legno di Wengè con piano composto da essenze di Ebano Makassar, Noce, Acero, Padouk e Ciliegio. Particolare del piano il taglio a sguancio che lo rende sottile. Gambe in legno massello di Wengè. Finitura: F32 Design Maurizio Duranti
PESO: 38 kg - m³: 0,65 - **COLLI:** 1

MEASURES: L 120 W 120 H 38
DESCRIPTION: coffee table made of wengè wood. The top is veneered with Makassar Ebony, Walnut, Maple, Cherry and Padouk. Splay cut top. Legs made of solid Wengè. Finishing: F32 Design Maurizio Duranti
WEIGHT: 38 kg - m³: 0,65 - **PIECES:** 1

ART. 5698
TAVOLINO SCACCHI

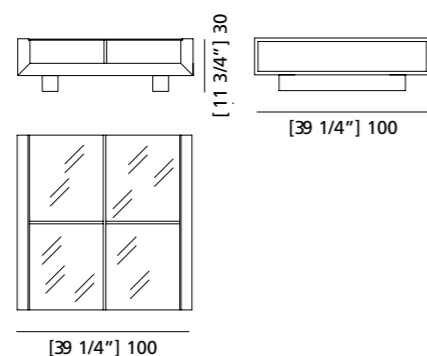

MISURE: L 100 P 100 H 30
DESCRIZIONE: tavolino quadrato in legno di ciliegio con 4 compartimenti portaoggetti e piano in cristallo. Finitura: F60 Design Centro Ricerche MAMM
PESO: 59 kg - m³: 0,3 - **COLLI:** 1

MEASURES: L 100 W 100 H 30
DESCRIPTION: coffee table made of cherry wood with 4 storage trays and glass top. Finishing: F60 Design by centro Ricerche MAMM
WEIGHT: 59 kg - m³: 0,3 - **PIECES:** 1

ART. 5640
TAVOLINO SCACCHI

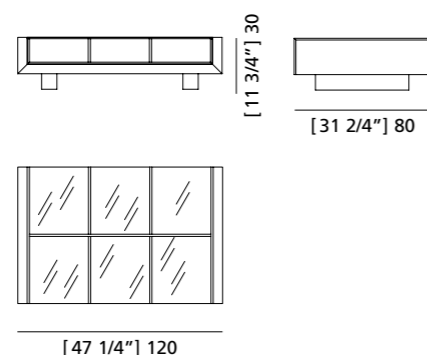

MISURE: L 120 P 80 H 30
DESCRIZIONE: tavolino rettangolare in legno di ciliegio con 6 compartimenti portaoggetti e piano in cristallo. Finitura: F60 Design Centro Ricerche MAMM
PESO: 59 kg - m³: 0,41 - **COLLI:** 1

MEASURES: L 120 W 80 H 30
DESCRIPTION: rectangular coffee table made of cherry wood with 6 storage trays and glass top. Finishing: F60 Design by centro Ricerche MAMM
WEIGHT: 59 kg - m³: 0,41 - **PIECES:** 1

ART. 5696
TAVOLINO BIEDERMEIER

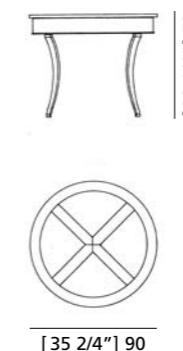

MISURE: diam. 90 H 72
DESCRIZIONE: tavolino rotondo in legno di ciliegio con gambe sagomate. Pregiata impiallacciatura del piano. Finitura: F60 Design Centro Ricerche MAMM
PESO: 22 kg - m³: 0,65 - **COLLI:** 1

MEASURES: diam. 90 H 72
DESCRIPTION: round coffee table made of cherry wood with shaped legs and veneered top. Finishing: F60 Design by centro Ricerche MAMM
WEIGHT: 22 kg - m³: 0,65 - **PIECES:** 1

ART. 5664
TAVOLINO BIEDERMEIER

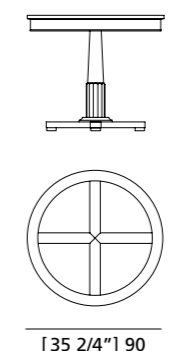

MISURE: diam. 90 H 77
DESCRIZIONE: tavolino rotondo in legno di ciliegio con gamba centrale intagliata. Pregiata impiallacciatura del piano. Finitura: F60 Design Centro Ricerche MAMM
PESO: 27 kg - m³: 0,60 - **COLLI:** 1

MEASURES: diam. 90 H 77
DESCRIPTION: round coffee table made of cherry wood with carved central leg and veneered top. Finishing: F60 Design by centro Ricerche MAMM
WEIGHT: 27 kg - m³: 0,60 - **PIECES:** 1

ART. 5688
TAVOLINO DIRETTORIO

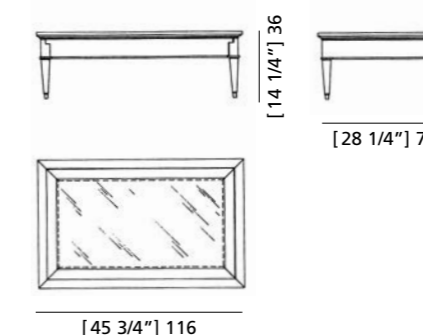

MISURE: L 116 P 72 H 36
DESCRIZIONE: tavolino bacheca rettangolare con piano in cristallo e interno del cassetto rivestito in pelle o tessuto. Finitura: F60 Design Centro Ricerche MAMM
PESO: 40 kg - m³: 0,4 - **COLLI:** 1

MEASURES: L 116 W 72 H 36
DESCRIPTION: rectangular showcase table with glass top and interior of the drawer covered in leather or fabric. Finishing: F60 Design by centro Ricerche MAMM
WEIGHT: 40 kg - m³: 0,4 - **PIECES:** 1

ART. 5801/F
CONSOLLE SWING

CUSTOMIZABLE

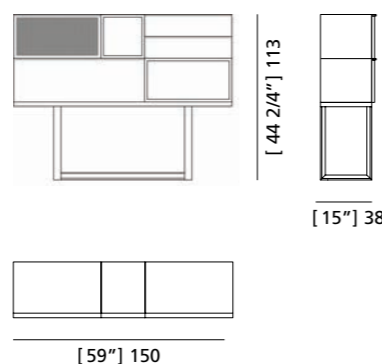

MISURE: L 150 P 38 H 113
DESCRIZIONE: Consolle in legno di frassino composta da moduli con cassetto e moduli a giorno, base con struttura in legno.
PESO: 40 kg - m³: 0,65 - COLLI: 1

MEASURES: L 150 P 38 H 113
DESCRIPTION: Consolle in ash wood with doors, drawers and open element.
WEIGHT: 40 kg - m³: 0,65 - PIECES: 1

ART. 5818
CONSOLLE CAVALLETTO ZERO

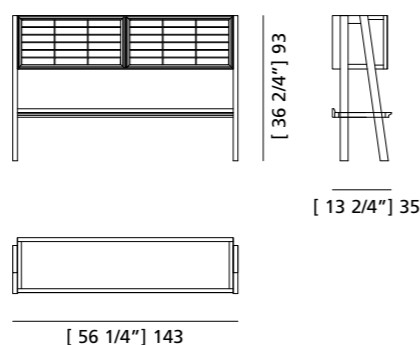

MISURE: L 143 P 35 H 93
DESCRIZIONE: consolle con contenitore a 2 elementi più vano a giorno con mensola, mobile della collezione Zero, art. 3477 con antine a ribalta art. 3455 in finitura FL100. Struttura a "cavalletto" in legno di ciliegio. Disponibile con altre ante della collezione Zero. Finitura: F30. Design Centro Ricerche MAMM

MEASURES: L 143 W 35 H 93
DESCRIPTION: consolle table with 1 shelf and 1 Zero structure art. 3455 with flap doors art. 3498. "Cavalletto" structure made of solid cherry wood, also available with other doors of the Zero collection. Finishing: F30. Design by centro Ricerche MAMM
WEIGHT: 47 kg - m³: 0,65 - PIECES: 1

ART. 5815
CONSOLLE BIEDERMEIER

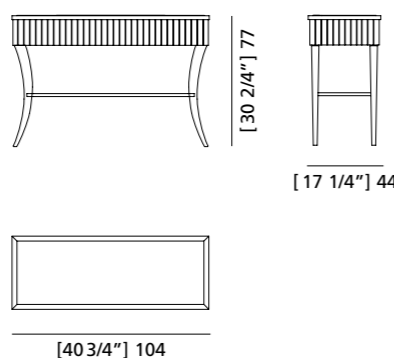

MISURE: L 104 P 44 H 77
DESCRIZIONE: consolle in legno di ciliegio con pregiata fresatura a lesene sul frontale. Due cassetti laterali e uno centrale con specchio estraibile. Finitura: F60 Design Centro Ricerche MAMM
PESO: 34 kg - m³: 0,47
COLLI: 1

MEASURES: L 104 W 44 H 77
DESCRIPTION: console made of cherry wood with fine milling on the front. Two side drawers and one central drawer with extractable mirror. Finishing: F60 Design by centro Ricerche MAMM
WEIGHT: 34 kg m³: 0,47
PIECES: 1

ART. 5812
TAVOLO CONSOLLE BIEDERMEIER

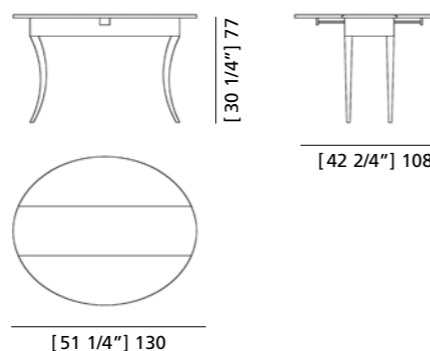

MISURE: L 130 P 45 H 77
DESCRIZIONE: tavolo - Consolle rettangolare apribile con due alette laterali con finitura bifacciale e gambe a sciabola. Finitura: F60 Design Centro Ricerche MAMM
MISURE APERTO: L 130 P 108 H 77
PESO: 35 kg - m³: 0,6 - COLLI: 1

MEASURES: L 130 W 45 H 77
DESCRIPTION: rectangular consolle table with 2 lateral extensions. Shaped legs. Finished on all sides. Finishing: F60 Design by centro Ricerche MAMM
OPEN SIZE: L 130 P 108 H 77
WEIGHT: 35 kg - m³: 0,6 - PIECES: 1

ART. 0419/N
SERVOMUTO IDEALISTA

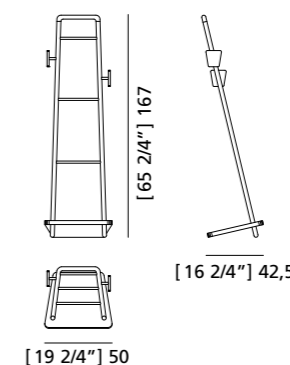

MISURE: L 50 P 42,5 H 167
DESCRIZIONE: interamente realizzato in legno massello di noce canaletto. Il progetto ha partecipato all'edizione 2014 del Concorso "Il Mobile Significante". Design: Monica Rocio Bohorquez
PESO: 6 kg - m³: 0,40 COLLI: 1

MEASURES: L 50 W 42,5 H 167
DESCRIPTION: entirely made of solid walnut. Project that took part in the 2014 edition of the Competition "Significant Furniture" Design: Monica Rocio Bohorquez
WEIGHT: 6 kg - m³: 0,40 PIECES: 1

ART. 5415
SPECCHIO '900

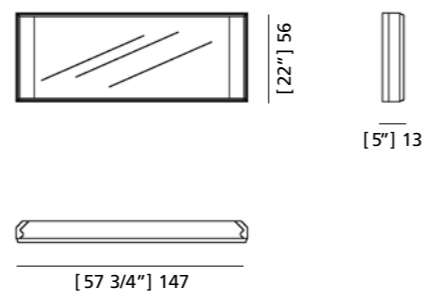

MISURE: L 147 P 13 H 56
DESCRIZIONE: specchio con cornice in legno di ciliegio intagliato, da appoggio o con ganci per fissaggio a muro.
Finitura: F30
Design Centro Ricerche MAM
PESO: 15 kg - m³: 0,25
COLLI: 1

MEASURES: L 147 W 13 H 56
DESCRIPTION: mirror with carved wooden frame made of cherry wood. Standing or hanging. Finishing: F30
Design by centro Ricerche MAM
WEIGHT: 15 kg - m³: 0,25
PIECES: 1

ART. 5406
SPECCHIO DIRETTORIO

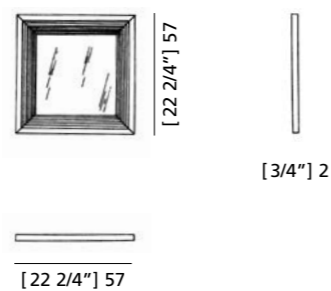

MISURE: L 57 P 2 H 57
DESCRIZIONE: specchio quadrato a parete con cornice intagliata in legno di ciliegio. Finitura: F60
Design Centro Ricerche MAM
PESO: 6 kg - m³: 0,05
COLLI: 1

MEASURES: L 57 W 2 H 57
DESCRIPTION: hanging square mirror with fine milling on the frame made of cherry wood. Finishing: F60
Design by centro Ricerche MAM
WEIGHT: 6 kg - m³: 0,05
PIECES: 1

ART. 5405
SPECCHIO DIRETTORIO

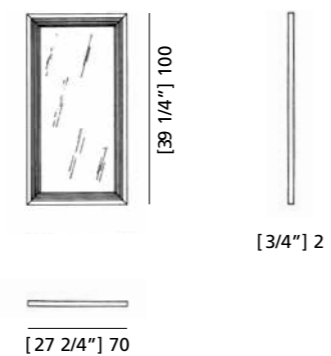

MISURE: L 70 P 2 H 100
DESCRIZIONE: specchio rettangolare a parete con cornice intagliata in legno di ciliegio. Finitura: F60
Design Centro Ricerche MAM
PESO: 10 kg - m³: 0,05
COLLI: 1

MEASURES: L 70 W 2 H 100
DESCRIPTION: hanging rectangular mirror with fine milling on the frame made of cherry wood. Finishing: F60
Design by centro Ricerche MAM
WEIGHT: 10 kg - m³: 0,05
PIECES: 1

DIVANI
POLTRONE
DORMEUSE
DIVANI LETTO

SOFAS
ARMCHAIRS
DORMEUSE
SOFA-BEDS



ART. 3820/F
POLTRONCINA MOBY DICK

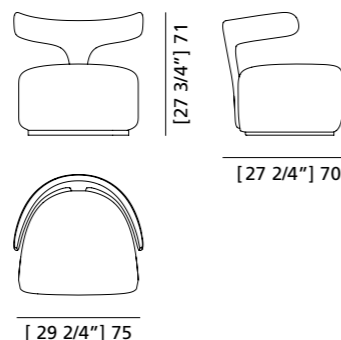

MISURE: L 75 P 70 H 71 HS 38
DESCRIZIONE: Poltroncina in legno di frassino con struttura che richiama la coda di una balena, seduta imbottita e rivestita. Design Libero Rutilo
PESO: 25 kg - m³: 0,40 - COLLI: 1

MEASURES: L 75 P 70 H 71 HS 38
DESCRIPTION: Armchair with solid ash wood backrest resembling the whale tail. Design Libero Rutilo
WEIGHT: 25 kg - m³: 0,40 - PIECES: 1

ART. 3823/F
CHAISE LONGUE JOYCE

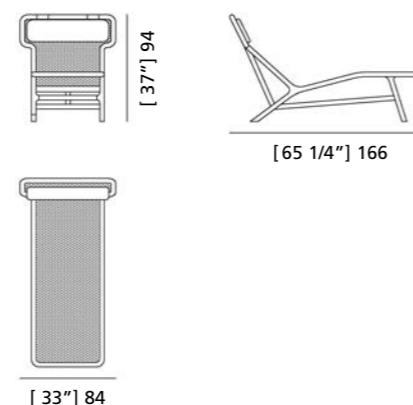

MISURE: L 84 P 166 H 94 HS 32/44
DESCRIZIONE: Chaise longue con struttura in legno di frassino, seduta in paglia di Vienna, cuscino imbottito applicato allo schienale. Design Libero Rutilo
PESO: 30 kg - m³: 1,30 - COLLI: 1

MEASURES: L 84 P 166 H 94 HS 32/44
DESCRIPTION: Chaise Longue made of solid ash wood, with Vienna straw seat and leather head cushion. Design Libero Rutilo
WEIGHT: 30 kg - m³: 1,30 - PIECES: 1

ART. 3814/F
POLTRONA JOYCE

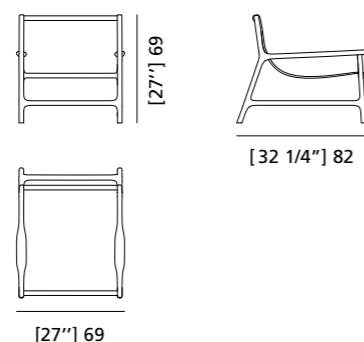

MISURE: L 69 P 82 H 69 HS 38
DESCRIZIONE: Lounge chair in legno di frassino tornito con seduta in pelle trapuntata e puntali in ottone. Design: Libero Rutilo
MISURE SEDUTA: L 56 P 49 H 43
PESO: 20 kg - m³: 0,45 - COLLI: 1

MEASURES: L 69 P 82 H 69 HS 38
DESCRIPTION: Lounge chair made of turned ash wood with quilted leather seat and brass tips. Design: Libero Rutilo
SIZE SEAT: L 56 W 49 H 43
WEIGHT: 20 kg - m³: 0,45 - PIECES: 1

ART. 3899/A
POLTRONA CHAISE MORELATO

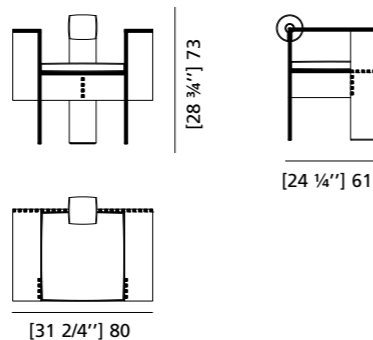

MISURE: L 80 P 61 H 73 HS 45
DESCRIZIONE: poltrona in legno multistrato di betulla e impiallacciato in acero da 16mm assemblata con incastri a pettine. Seduta e schienale imbottiti in pelle. Progetto donato alla Fondazione Aldo Morelato durante il X concorso "Il Mobile Significante". Design: Mario Botta
PESO: 15 kg. - m³: 0,43 - COLLI: 1

MEASURES: L 80 W 61 H 73 HS 45
DESCRIPTION: armchair made of birch plywood with maple veneer, assembled by comb joints. Seat and back upholstered with leather. Project donated to the Aldo Morelato Foundation on occasion of the 10th edition of the "Significant furniture" competition Design: Mario Botta
WEIGHT: 15 kg. - m³: 0,43 - PIECES: 1

ART. 3811/F
POLTRONA AIDA

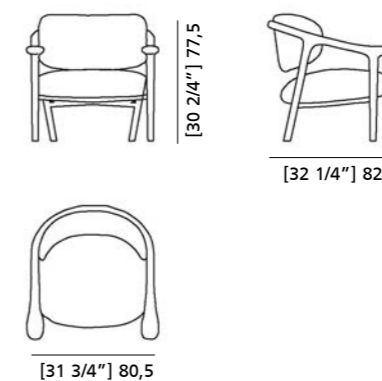

MISURE: L 80,5 P 82 H 77,5
DESCRIZIONE: Poltroncina in legno di frassino curvato, seduta e schienale imbottiti. Design Libero Rutilo
PESO: 20 kg - m³: 0,6 - COLLI: 1

MEASURES: L 80,5 W 82 H 77,5
DESCRIPTION: Armchair in solid ash wood, with upholstered seat and back. Design Libero Rutilo
WEIGHT: 20 kg - m³: 0,6 - PIECES: 1

ART. 3898
POLTRONA DONDOLO BURTON

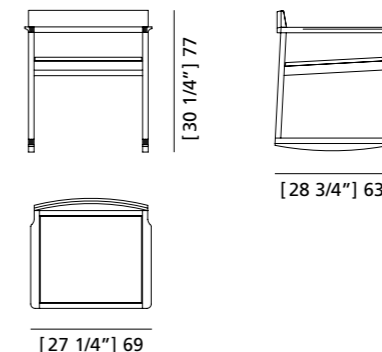

MISURE: L 69 P 63 H 77 HS 44
DESCRIZIONE: poltroncina dondolo in legno di ciliegio con seduta imbottita e particolari incastri a pettine. Trasformabile in dondolo con l'applicazione di 2 pattini curvi calamitati. Tessuto occorrente: cm 70x140. Finitura: F32/C. Design Centro Ricerche
PESO: 15 kg - m³: 0,4 - COLLI: 1

MEASURES: L 69 W 63 H 77 HS 44
DESCRIPTION: rocking armchair made of cherry wood with upholstered seat. Converts into a rocking chair with the application of 2 curved magnetized pieces. Required fabric: 70x140 cm. Finishing: F32/C. Design by centro Ricerche
WEIGHT: 15 kg - m³: 0,4 - PIECES: 1

ART. 3802/N
POLTRONA MALIBÙ

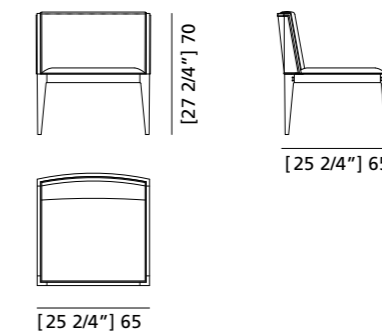

MISURE: L 65 P 65 H 70 HS 38
DESCRIZIONE: poltroncina bassa in legno di noce canaletto con seduta e schienale imbottiti. Schienale rivestito sul retro con particolare maniglia intagliata nel legno. Tessuto occorrente: cm 120x140. Finitura: F32/N. Design Centro Ricerche
PESO: 10 kg - m³: 0,4 COLLI: 1

MEASURES: L 65 W 65 H 70 HS 38
DESCRIPTION: lounge chair made of walnut wood with upholstered seat and back. Special handle carved in the wood on the upholstered back. Required fabric: 120x140 cm. Finish: F32/N. Design by centro Ricerche
WEIGHT: 10 kg - m³: 0,4 PIECES: 1

ART. 3878
POLTRONA AURELIA

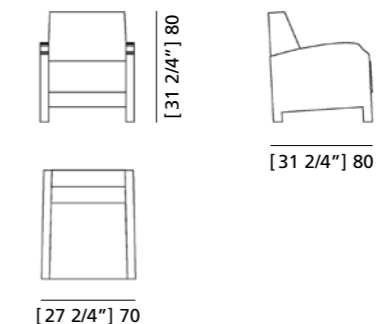

MISURE: L 70 P 80 H 80 HS 48
DESCRIZIONE: poltrona con struttura in legno di ciliegio e pregiata impiallacciatura sul bracciolo. Seduta e schienale imbottiti. Tessuto occorrente: cm 400x140. Finitura: F30. Design: Ugo la Pietra
MISURE SEDUTA: L 56 P 49 H 43
PESO: 40 kg - m³: 0,55 - COLLI: 1

MEASURES: L 70 W 80 H 80 HS 48
DESCRIPTION: armchair made of cherry wood with fine veneered armrests. Upholstered seat and back. Required fabric: 400x140 cm. Finishing: F30. Design: Ugo la Pietra
SIZE SEAT: L 56 W 49 H 43
WEIGHT: 40 kg - m³: 0,55 - PIECES: 1

ART. 2247/F
DIVANO BELLAGIO

CUSTOMIZABLE

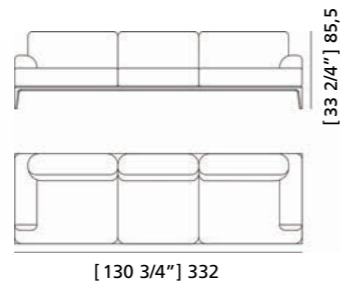

MISURE: L 332 P 100 H 85,5 HS 50
DESCRIZIONE: Divano con struttura in legno di frassino, cuscini schienale e seduta imbottiti e rivestiti.
Design Libero Rutilo
PESO: 110 kg - m³: 2,65 - COLLI: 2

MEASURES: L 332 P 100 H 85,5 HS 50
DESCRIPTION: Modular sofa with wooden structure.
Design Libero Rutilo
WEIGHT: 110 kg - m³: 2,65 - PIECES: 2

ART. 2245/F
DIVANO BELLAGIO

CUSTOMIZABLE

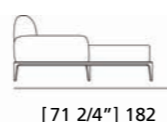
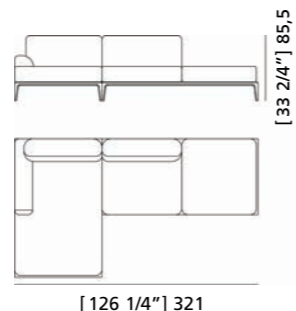

MISURE: L 321 P 182 H 85,5 HS 50
DESCRIZIONE: Divano con struttura in legno di frassino, cuscini schienale e seduta imbottiti e rivestiti.
Design Libero Rutilo
PESO: 130 kg - m³: 4,6 - COLLI: 2

MEASURES: L 321 P 182 H 85,5 HS 50
DESCRIPTION: Modular sofa with wooden structure.
Design Libero Rutilo
WEIGHT: 130 kg - m³: 4,6 - PIECES: 2

ART. 2246/F
DIVANO BELLAGIO

CUSTOMIZABLE

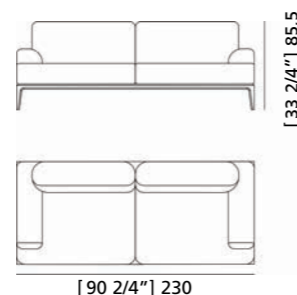

MISURE: L 230 P 100 H 85,5 HS 50
DESCRIZIONE: Divano con struttura in legno di frassino, cuscini schienale e seduta imbottiti.
Design Libero Rutilo
PESO: 80 kg - m³: 1,85 COLLI: 1

MEASURES: L 230 P 100 H 85,5 HS 50
DESCRIPTION: Modular sofa with wooden structure.
Design Libero Rutilo
WEIGHT: 80 kg - m³: 1,85 PIECES: 1

ART. 2249/F
DIVANO BELLAGIO

CUSTOMIZABLE

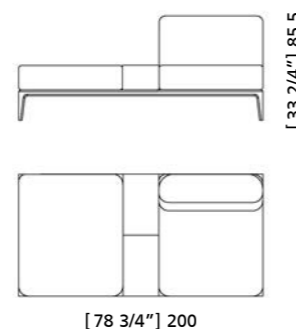

MISURE: L 200 P 100 H 85,5 HS 50
DESCRIZIONE: Divano con struttura in legno di frassino, cuscini schienale e seduta imbottiti. Tra le due sedute è presente un vano chiuso da anta a ribalta e un cassetto a scomparsa. Design Libero Rutilo
PESO: 60 kg - m³: 1,7 COLLI: 1

MEASURES: L 200 P 100 H 85,5 HS 50
DESCRIPTION: Sofa with ash wood structure, padded back and seat cushions covered in fabric or leather. Between the two seats there is a compartment closed by a flap and a retractable drawer.
Design Libero Rutilo
WEIGHT: 60 kg - m³: 1,7 PIECES: 1

ART. 2241
DIVANO LETTO GIÒ

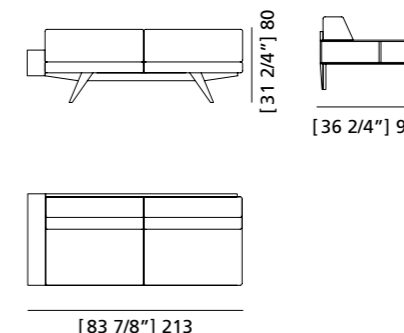

MISURE: L 213 P 93 H 80 HS
DESCRIZIONE: divano letto con struttura in legno di ciliegio e bracciolo con vano contenitore a giorno. Cuscini imbottiti in pelle o tessuto. Tessuto occorrente: cm 900x140. Finitura: F32/C.
Design Centro Ricerche
PESO: 80 kg - m³: 1,5 - COLLI: 1

MEASURES: L 213 W 93 H 80 HS
DESCRIPTION: sofa bed with cherry wood frame and armrest with storage compartment. Cushions upholstered with leather or fabric. Required fabric: 900x140 cm. Finishing: F32/C.
Design by centro Ricerche
WEIGHT: 80 kg - m³: 1,5 - PIECES: 1

ART. 3886
POLTRONA MILANO

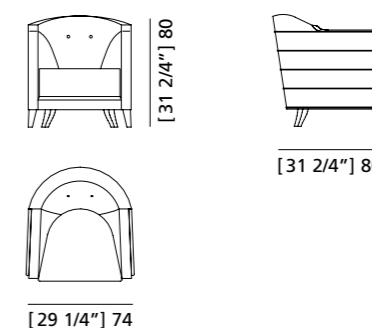

MISURE: L 74 P 80 H 80 HS 40
DESCRIZIONE: poltrona imbottita con struttura in legno di ciliegio. Particolare lavorazione dell'imbottitura a profili circolari. Tessuto occorrente: cm 600x140. Finitura: F30
Design Centro Ricerche
PESO: 32 kg - m³: 0,7 - COLLI: 1

MEASURES: L 74 W 80 H 80 HS 40
DESCRIPTION: upholstered armchair made of cherry wood. Special processing of the padding into circular profiles. Required fabric: 600x140 cm. Finishing: F30
Design by centro Ricerche
WEIGHT: 32 kg - m³: 0,7 - PIECES: 1

ART. 2235
DIVANO MILANO

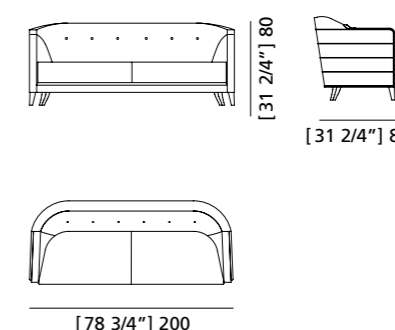

MISURE: L 200 P 80 H 80 HS 40
DESCRIZIONE: divano imbottito con struttura in legno di ciliegio. Particolare lavorazione dell'imbottitura a profili circolari. Tessuto occorrente: cm 1100x140. Finitura: F30
Design Centro Ricerche
PESO: 73 kg - m³: 1,8 - COLLI: 1

MEASURES: L 200 W 80 H 80 HS 40
DESCRIPTION: upholstered sofa made of cherry wood. Special processing of the padding into circular profiles. Required fabric: 1100x140 cm. Finishing: F30
Design by centro Ricerche
WEIGHT: 73 kg - m³: 1,8 - PIECES: 1

ART. 3894
POLTRONA TORINO

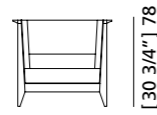

[30 3/4"] 78



[31 2/4"] 80

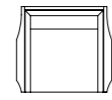

[34 2/4"] 88

MISURE: L 88 P 80 H 78 **HS 44**
DESCRIZIONE: poltrona imbottita con struttura in legno di ciliegio. Imbottitura interna ed esterna. Tessuto occorrente: cm 600x140. Finitura: F32/C
Design Centro Ricerche
PESO: 30 kg - m³: 0,65 - **COLLI:** 1

MEASURES: L 88 W 80 H 78 **HS 44**
DESCRIPTION: upholstered armchair with structure made of cherry wood. Upholstered inside and outside. Required fabric: 600x140 cm. Finishing: F32/C
Design by centro Ricerche
WEIGHT: 30 kg - m³: 0,65 - **PIECES:** 1

ART. 2238
DIVANO TORINO

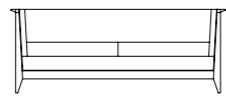

[30 3/4"] 78

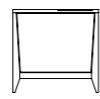

[31 2/4"] 80

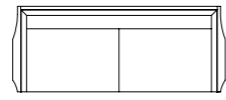

[78"] 198

MISURE: L 198 P 80 H 78 **HS 44**
DESCRIZIONE: divano imbottito con struttura in legno di ciliegio. Imbottitura interna ed esterna. Tessuto occorrente: cm 1050x140. Finitura: F32/C
Design Centro Ricerche
PESO: 70 kg - m³: 1,6 - **COLLI:** 1

MEASURES: L 198 W 80 H 78 **HS 44**
DESCRIPTION: upholstered sofa with structure made of cherry wood. Upholstered inside and outside. Required fabric: 1050x140 cm. Finishing: F32/C
Design by centro Ricerche
WEIGHT: 70 kg - m³: 1,6 - **PIECES:** 1

ART. 3853
POLTRONA '900 CLUB



[33 3/4"] 86



[31 2/4"] 80



[30"] 76

MISURE: L 76 P 80 H 86 **HS 48**
DESCRIZIONE: poltrona imbottita con struttura interna in legno e molle d'acciaio. Particolare profilo in legno sul bracciolo frontale. Tessuto occorrente: cm 450x140. Finitura: F60
Design Centro Ricerche
MISURE SEDUTA: L 50 P 52 H 53
PESO: 25 kg - m³: 0,6 - **COLLI:** 1

MEASURES: L 76 W 80 H 86 **HS 48**
DESCRIPTION: upholstered armchair with wooden frame and steel springs. Required fabric: 450x140 cm. Finishing: F60
Design by Centro Ricerche
SIZE SEAT: L 50 W 52 H 53
WEIGHT: 25 kg - m³: 0,6 - **PIECES:** 1

ART. 2228
DIVANO '900 CLUB

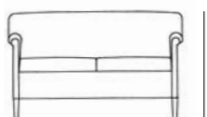

[33 3/4"] 86



[31 2/4"] 80



[54"] 137

MISURE: L 137 P 80 H 86 **HS 48**
DESCRIZIONE: divanetto imbottito con struttura interna in legno e molle d'acciaio. Particolare profilo in legno sul bracciolo frontale. Tessuto occorrente: cm 650x140. Finitura: F60
Design Centro Ricerche
MISURE SEDUTA: L 103 P 52 H 58
PESO: 36 kg - m³: 1 - **COLLI:** 1

MEASURES: L 137 W 80 H 86 **HS 48**
DESCRIPTION: upholstered sofa with wooden frame and steel springs. Required fabric: 650x140 cm. Finishing: F60
Design by Centro Ricerche
SIZE SEAT: L 103 W 52 H 58
WEIGHT: 36 kg - m³: 1 - **PIECES:** 1

ART. 3873
POLTRONCINA BIEDERMEIER



[31 2/4"] 80



[23 2/4"] 60

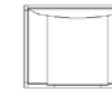

[30 1/4"] 77

MISURE: L 77 P 60 H 80 **HS 40**
DESCRIZIONE: poltroncina in legno di ciliegio finemente intagliato con schienale sagomato e imbottitura interna ed esterna. Tessuto occorrente: cm 350x140. Finitura: F60
Design Centro Ricerche
PESO: 25 kg - m³: 0,46 - **COLLI:** 1

MEASURES: L 77 W 60 H 80 **HS 40**
DESCRIPTION: armchair made of cherry wood finely carved with shaped upholstered back and seat. Required fabric: 350x140 cm. Finishing: F60
Design by centro Ricerche
WEIGHT: 25 kg - m³: 0,46 - **PIECES:** 1

ART. 2231
DIVANETTO BIEDERMEIER

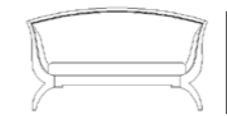

[32 3/4"] 83

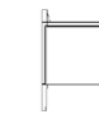

[23 2/4"] 60

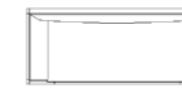

[56 1/4"] 143

MISURE: L 143 P 60 H 83 **HS 40**
DESCRIZIONE: divanetto in legno di ciliegio finemente intagliato con schienale sagomato e imbottitura interna ed esterna. Tessuto occorrente: cm 500x140. Finitura: F60
Design Centro Ricerche
PESO: 34 kg - m³: 0,78 - **COLLI:** 1

MEASURES: L 143 W 60 H 83 **HS 40**
DESCRIPTION: sofa made of cherry wood finely carved with shaped upholstered back and seat. Required fabric: 500x140 cm. Finishing: F60
Design by centro Ricerche
WEIGHT: 34 kg - m³: 0,78 - **PIECES:** 1

ART. 2242
DORMEUSE PAOLINA

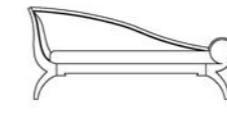

[29 2/4"] 75



[23 2/4"] 60

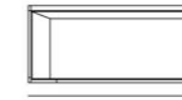



[62 3/4"] 160

MISURE: L 160 P 60 H 75 **HS 38**
DESCRIZIONE: dormeuse con struttura in legno di ciliegio sagomato, seduta e schienale imbottiti con rivestimento in pelle o tessuto. Finitura: F34
Tessuto occorrente: cm 350x140
Design Centro Ricerche
PESO: 30 kg - m³: 0,83 - **COLLI:** 1

MEASURES: L 160 W 60 H 75 **HS 38**
DESCRIPTION: chaise longue made of shaped cherry wood, upholstered seat and back in leather or fabric. Finishing: F34
Required fabric: cm 350x140
Design by centro Ricerche
WEIGHT: 30 kg - m³: 0,83 - **PIECES:** 1

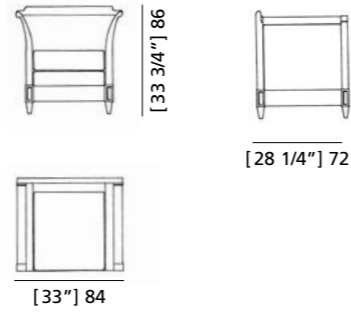
ART. 3860
POLTRONA VERONA





MISURE: L 84 P 72 H 86 **HS 48**
DESCRIZIONE: poltrona imbottita con struttura interna in legno, fianchi sagomati ed imbottitura con molle d'acciaio. Tessuto occorrente: cm 450x140. Finitura: F60
Design Centro Ricerche 
MISURE SEDUTA: L 51 P 55 H 49
PESO: 32 kg - m³: 0,6 - **COLLI:** 1

MEASURES: L 84 W 72 H 86 **HS 48**
DESCRIPTION: armchair with wooden frame, shaped armrests and upholstery with steel springs. Required fabric: 450x140 cm. Finishing: F60.
Design by centro Ricerche 
SIZE SEAT: L 51 W 55 H 49
WEIGHT: 32 kg - m³: 0,6 - **PIECES:** 1

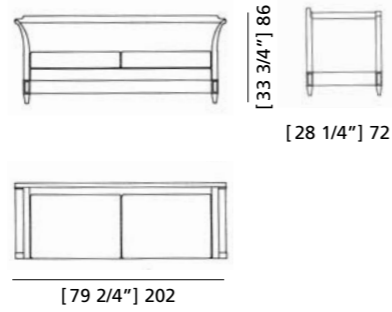
ART. 2227
DIVANO VERONA



MISURE: L 202 P 72 H 86 **HS 48**
DESCRIZIONE: divano imbottito con struttura interna in legno, fianchi sagomati ed imbottitura con molle d'acciaio. Tessuto occorrente: cm 900x140. Finitura: F60
Design Centro Ricerche 
MISURE SEDUTA: L 167 P 55 H 52
PESO: 63 kg - m³: 1,46 - **COLLI:** 1

MEASURES: L 202 W 72 H 86 **HS 48**
DESCRIPTION: sofa with wooden frame, shaped armrests and upholstery with steel springs. Required fabric: 450x140 cm. Finishing: F60. Design by centro Ricerche 
SIZE SEAT: L 167 W 55 H 52
WEIGHT: 63 kg - m³: 1,46 - **PIECES:** 1

ART. A1600075
CUSCINO CON BOTTONI



Cuscino per divano con bottoni.
Confezionato a mano, è disponibile in tutte le varianti della cartella tessuti e in tessuto cliente.

TESSUTO OCCORRENTE: cm 50 x 100

Handmade cushion with buttons for sofas. It is available in all fabrics coming from the Morelato sample folder but also customer fabric can be used.

FABRIC NEEDED: cm 50 x 100

LETTI

BEDS



ART. 2807/F
LETTO BELLAGIO

CUSTOMIZABLE

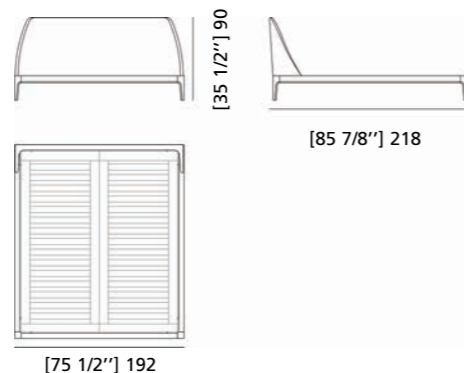

MISURE: L 192 P 218 H 90
DESCRIZIONE: Letto in legno di frassino con testiera imbottita.
Design: Libero Rutilo
PESO: 100 kg - m³: 1,3
COLLI: 4

MEASURES: L 192 P 218 H 90
DESCRIPTION: Bed made of ash wood with upholstered headboard.
Design: Libero Rutilo
WEIGHT: 100 kg - m³: 1,3
PIECES: 4

ART. 2808/F
LETTO BELLAGIO

CUSTOMIZABLE

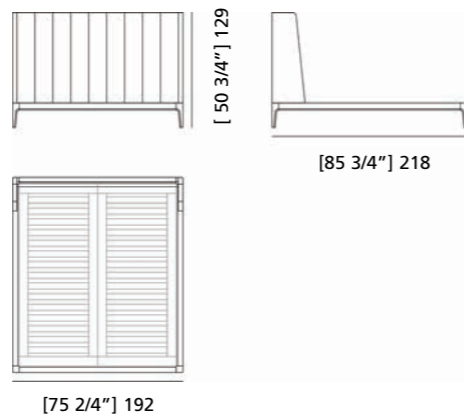

MISURE: L 192 P 218 H 129
DESCRIZIONE: Letto con struttura in legno di frassino, testiera imbottita e rivestita in tessuto, piede a spillo. Supporto materasso con doghe in legno di faggio.
Design Libero Rutilo
PESO: 110 kg - m³: 1,40 - COLLI: 4

MEASURES: L 192 P 218 H 129
DESCRIPTION: Bed made ash wood with upholstered headboard.
Design Libero Rutilo
WEIGHT: 110 kg - m³: 1,40 - PIECES: 4

ART. 2809/F
LETTO JOYCE

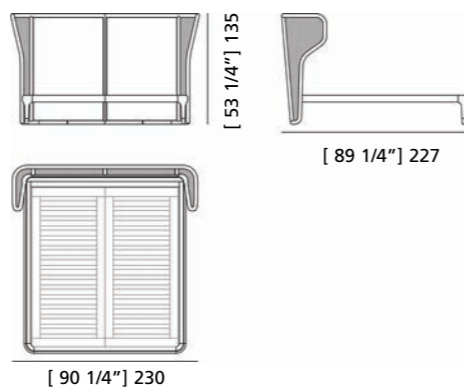

MISURE: L 230 P 227 H 135
DESCRIZIONE: Letto con struttura in legno di frassino, testiera in parte imbottita e rivestita in tessuto, in parte in paglia di Vienna, piedi sagomati con bicchierino in ottone. Supporto materasso con doghe in legno di faggio.
Design Libero Rutilo
PESO: 120 kg - m³: 2,20 - COLLI: 4

MEASURES: L 230 P 227 H 135
DESCRIPTION: Bed made of solid ash wood with upholstered headboard and side Vienna straw lining.
Design Libero Rutilo
WEIGHT: 120 kg - m³: 2.20 - PIECES: 4

ART. 2802/F
LETTO SWING

CUSTOMIZABLE

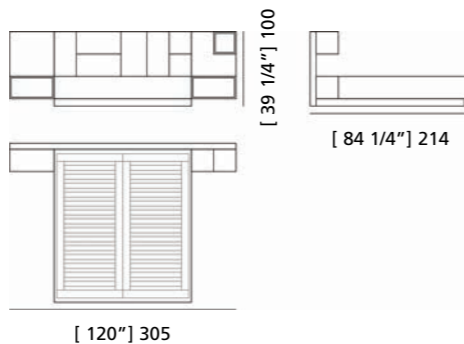

MISURE: L 305 P 214 H 100
DESCRIZIONE: Letto con struttura in legno di frassino, testiera e giro letto rivestiti in tessuto, comodini e modulo a giorno applicati alla testiera. Supporto materasso con doghe in legno di faggio.
Design Libero Rutilo
PESO: 150 kg - m³: 2,00 - COLLI: 5

MEASURES: L 305 P 214 H 100
DESCRIPTION: Upholstered bed made of ash wood, with cushions on headboard. Lifiable slatted base.
Design Libero Rutilo
WEIGHT: 150 kg - m³: 2,00 - PIECES: 5

ART. 2889/F
LETTO MAGIC DREAM

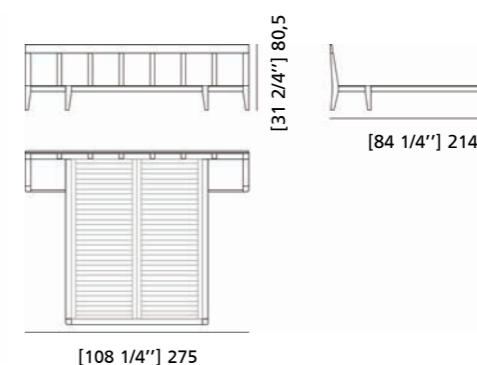

MISURE: L 275 P 214 H 80,5
DESCRIZIONE: Letto con struttura in legno di frassino. 2 comodini con cassetto integrati nella testiera in legno massello. Supporto con doghe di legno. Su richiesta cuscini imbottiti applicabili alla testiera.
Design: Giuseppe Viganò
PESO: 100 kg - m³: 1,3 - COLLI: 3

MEASURES: L 275 W 214 H 80,5
DESCRIPTION: Bed made of ash wood with two integrated bedside tables into the headboard. Wooden slats mattress support. Upon request removable padded cushions for the headboard.
Design: Giuseppe Viganò
WEIGHT: 100 kg - m³: 1,3 - PIECES: 3

ART. 2890
LETTO FELICE

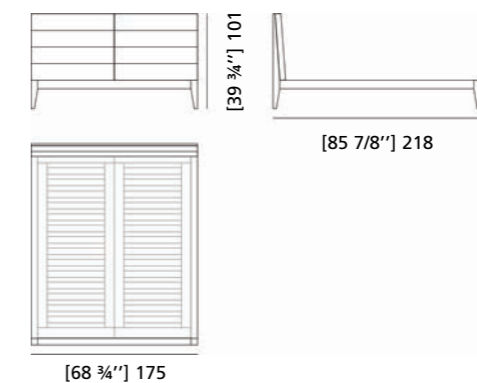

MISURE: L 175 P 218 H 101
DESCRIZIONE: Letto con struttura in legno di ciliegio e piedini con bordo stondato. Testiera a doghe di legno con 2 cuscini removibili, imbottiti e sfoderabili in pelle o tessuto. Supporto con doghe di legno. Finitura: F32/C. Tessuto occorrente: cm 350x140
Design Centro Ricerche MAM
PESO: 85 kg - m³: 1 - COLLI: 3

MEASURES: L 175 W 218 H 101
DESCRIPTION: Bed made of cherry wood with headboard made of wooden poles with removable padded cushions. Wooden slats mattress support. Finishing: F32/C. Required fabric: cm 350x140
Design by centro Ricerche MAM
WEIGHT: 85 kg - m³: 1 - PIECES: 3

ART. 2887
LETTO GIÒ

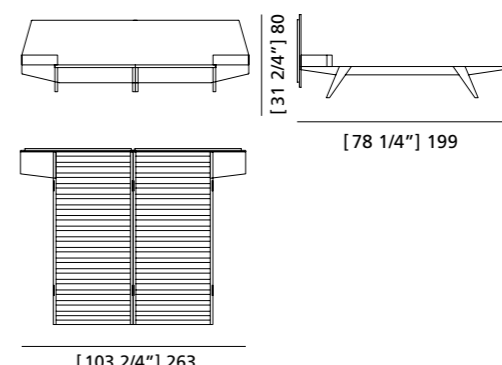

MISURE: L 263 P 199 H 80
DESCRIZIONE: Letto con struttura in legno massello di ciliegio e supporto materasso in doghe. Testiera in legno con 2 comodini con cassetto integrati. Finitura: F32/C.
Design Centro Ricerche MAM
PESO: 114 kg - m³: 2,5 - COLLI: 3

MEASURES: L 263 W 199 H 80
DESCRIPTION: Bed with a solid cherry wood structure and headboard with integral bedside tables. Wooden slats mattress support. Finishing: F32/C.
Design by centro Ricerche MAM
WEIGHT: 114 kg - m³: 2,5 - PIECES: 3

ART. 2884
LETTO GIÒ

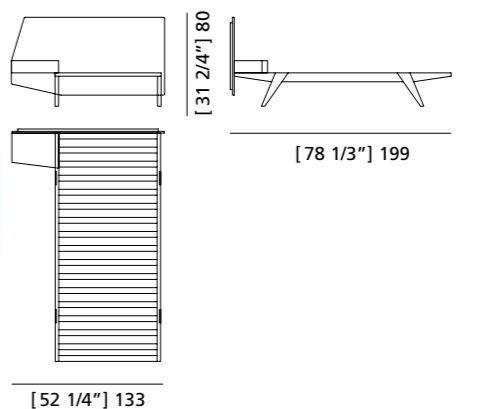

MISURE: L 133 P 199 H 80
DESCRIZIONE: Letto con struttura in legno massello di ciliegio e supporto materasso in doghe. Testiera in legno con comodino integrato con cassetto. Finitura: F32/C.
Design Centro Ricerche MAM
PESO: 55 kg - m³: 0,7 - COLLI: 2

MEASURES: L 133 W 199 H 80
DESCRIPTION: Bed with a solid cherry wood structure and headboard with bedside table. Wooden slats mattress support. Finishing: F32/C.
Design by centro Ricerche MAM
WEIGHT: 55 kg - m³: 0,7 - PIECES: 2

ART. 2806
LETTO FORTUNATO



MISURE: L 180 P 230 H 95
DESCRIZIONE: letto imbottito con struttura in legno di ciliegio. Imbottitura in pelle o tessuto su testiera e pediera. Supporto con doghe di legno.
Tessuto occorrente: cm 410x140
Design Centro Ricerche MAM
PESO: 80 kg - m³: 1 - COLLI: 4

MEASURES: L 180 W 230 H 95
DESCRIPTION: upholstered bed made of cherry wood. Leather or fabric upholstery on headboard and footboard. Wooden slats mattress support.
Required fabric: cm 410x140
Design by centro Ricerche MAM
WEIGHT: 80 kg - m³: 1 - PIECES: 4

ART. 2801
LETTO ORLANDO



MISURE: L 190 P 216 H 112
DESCRIZIONE: letto con vano contenitore in legno di ciliegio e pelle. Testiera con profilo in legno sagomato ad elica. Supporto materasso estraibile in doghe di legno. Tessuto occorrente: cm 550x140. Finitura: F32/C
Design Centro Ricerche MAM
PESO: 110 kg - m³: 2 - COLLI: 5

MEASURES: L 190 W 216 H 112
DESCRIPTION: bed with storage compartment made of cherry wood and leather. Upholstered headboard with wooden helical turned profile. Folding wooden slats mattress support. Required fabric: cm 550x140 Finishing: F32/C.
Design by centro Ricerche MAM
WEIGHT: 110 kg - m³: 2 - PIECES: 5

ART. 2891
LETTO VALENTINO CON BALDACCHINO

CUSTOMIZABLE



MISURE: L 183 P 208 H 200
DESCRIZIONE: letto in legno di ciliegio con testiera imbottita in pelle o tessuto e struttura a baldacchino. Supporto in doghe di legno. Tessuto occorrente: cm 250x140.
Design Centro Ricerche MAM
PESO: 100 kg - m³: 1 COLLI: 5

MEASURES: L 183 W 208 H 200
DESCRIPTION: bed made of cherry wood with fabric or leather upholstered headboard and baldachin. Wooden slats mattress support. Required fabric: cm 250x140.
Design by centro Ricerche MAM
WEIGHT: 100 kg - m³: 1 PIECES: 5

ART. 2850
LETTO RULMAN



MISURE: L 176 P 220 H 92
DESCRIZIONE: letto in legno di ciliegio con pregiata fresatura delle sponde e testiera imbottita bifacciale. Supporto in doghe di legno
Tessuto occorrente: cm 260x140. Finitura: F60
Design Centro Ricerche MAM
VANO INTERNO: L 170 P 195
PESO: 95 kg - m³: 1,05 - COLLI: 4

MEASURES: L 176 W 220 H 92
DESCRIPTION: bed made of cherry wood with fine milling on the lower profiles of the sides and upholstered double face headboard. Wooden slats mattress support. Wooden slats mattress support
Required fabric: cm 260x140. Finishing: F60
Design by centro Ricerche MAM
INTERNAL SIZE: L 170 W 195
WEIGHT: 95 kg - m³: 1,05 - PIECES: 4

ART. 2885
LETTO UMBERTO



MISURE: L 172 P 208 H 96
DESCRIZIONE: letto con struttura in legno di ciliegio, imbottita e rivestita come la testiera in pelle o tessuto. Supporto in doghe di legno. Tessuto occorrente: cm 390x140. Finitura: F34
Design Centro Ricerche MAM
PESO: 67 kg - m³: 1 - COLLI: 4

MEASURES: L 172 W 208 H 96
DESCRIPTION: bed made of cherry wood with upholstered headboard and sides. Wooden slats mattress support. Required fabric: cm 390x140. Finishing: F34
Design by centro Ricerche MAM
WEIGHT: 67 kg - m³: 1 - PIECES: 4

ART. 2821
LETTO LUIGI FILIPPO



MISURE: L 98 P 227 H 91
DESCRIZIONE: letto in legno di ciliegio con testiera, pediera e schienale in legno e gambette sagomate. Supporto in doghe di legno. Finitura: F60
Design Centro Ricerche MAM
VANO INTERNO: L 90 P 195
PESO: 74 kg - m³: 0,85 - COLLI: 4

MEASURES: L 98 W 227 H 91
DESCRIPTION: bed made of cherry wood with wooden headboard, footboard and backrest; shaped legs. Wooden slats mattress support. Finishing: F60
Design by centro Ricerche MAM
INTERNAL SIZE: L 90 W 195
WEIGHT: 74 kg - m³: 0,85 - PIECES: 4

ART. 2847
LETTO DIRETTORIO



MISURE: L 181 P 215 H 90
DESCRIZIONE: letto in legno di ciliegio con testiera sagomata. Su richiesta con testiera imbottita. Supporto in doghe di legno. Finitura: F34
Design Centro Ricerche MAM
VANO INTERNO: L 170 P 195
PESO: 80 kg - m³: 1 - COLLI: 3

MEASURES: L 181 W 215 H 90
DESCRIPTION: bed made of cherry wood with wooden headboard; carved legs. Wooden slats mattress support. Upon request with upholstered headboard. Finishing: F34
Design by centro Ricerche MAM
INTERNAL SIZE: L 170 W 195
WEIGHT: 80 kg - m³: 1 - PIECES: 3

ART. A1500015
MATERASSO ORTOPEDICO 170



Materasso ortopedico a fiocchi a due piazze, con molleggio garantito 12 anni. Imbottitura in puro cotone nel lato estivo, in lana bianca (70%) e altre fibre scelte di imbottiture bianche per lato invernale. Rivestito in tessuto di puro cotone. Trapuntatura a punti passanti con fiocchi. Spessore laterale cm 19. È dotato di quattro maniglie con occhielli e cerniera d'ispezione.

DIMENSIONI: L 170 P 195 H 19
PESO: kg 20 - m³: 0,70

Orthopaedic double mattress, 12 year-guaranteed springing. On the summer side pure cotton filling, on the winter side wool (70%) and other fibres. Pure cotton cover. Strong stitching with flakes. Lateral thickness 19 cm. The mattress has four handles and a zip to control the mattress.

SIZE: L 170 W 195 H 19
WEIGHT: kg 20 - m³: 0,70

ART. A1500025
MATERASSO ORTOPEDICO 86



Materasso ortopedico a fiocchi ad una piazza, con molleggio garantito 12 anni. Imbottitura in puro cotone nel lato estivo; in lana bianca (70%) e altre fibre scelte di imbottiture bianche per il lato invernale. Rivestito in tessuto puro cotone. Trapuntatura a punti passanti con fiocchi. Spessore laterale cm. 19. È dotato di quattro maniglie con occhielli e cerniera d'ispezione.

DIMENSIONI: L 86 P 195 H 19
PESO: kg 12 - m³: 0,40

Orthopaedic single mattress, 12 year-guaranteed springing. On the summer side pure cotton filling, on the winter side wool (70%) and other fibres. Pure cotton cover. Strong stitching with flakes. Lateral thickness 19 cm. The mattress has four handles and a zip to control the mattress.

SIZE: L 86 W 195 H 19
WEIGHT: kg 12 - m³: 0,40

ART. A1500015
MATERASSO ORTOPEDICO 180



Materasso ortopedico a fiocchi a due piazze, con molleggio garantito 12 anni. Imbottitura in puro cotone nel lato estivo, in lana bianca (70%) e altre fibre scelte di imbottiture bianche per lato invernale. Rivestito in tessuto di puro cotone. Trapuntatura a punti passanti con fiocchi. Spessore laterale cm 19. È dotato di quattro maniglie con occhielli e cerniera d'ispezione.

DIMENSIONI: L 180 P 200 H 19
PESO: kg 20 - m³: 0,70

Orthopaedic double mattress, 12 year-guaranteed springing. On the summer side pure cotton filling, on the winter side wool (70%) and other fibres. Pure cotton cover. Strong stitching with flakes. Lateral thickness 19 cm. The mattress has four handles and a zip to control the mattress.

SIZE: L 180 W 200 H 19
WEIGHT: kg 20 - m³: 0,70

ART. A1500025
MATERASSO ORTOPEDICO 90



Materasso ortopedico a fiocchi ad una piazza, con molleggio garantito 12 anni. Imbottitura in puro cotone nel lato estivo; in lana bianca (70%) e altre fibre scelte di imbottiture bianche per il lato invernale. Rivestito in tessuto puro cotone. Trapuntatura a punti passanti con fiocchi. Spessore laterale cm. 19. È dotato di quattro maniglie con occhielli e cerniera d'ispezione.

DIMENSIONI: L 90 P 200 H 19
PESO: kg 12 - m³: 0,40

Orthopaedic single mattress, 12 year-guaranteed springing. On the summer side pure cotton filling, on the winter side wool (70%) and other fibres. Pure cotton cover. Strong stitching with flakes. Lateral thickness 19 cm. The mattress has four handles and a zip to control the mattress.

SIZE: L 90 W 200 H 19
WEIGHT: kg 12 - m³: 0,40

ART. A1600075
CUSCINO CON BOTTONI



Cuscino per divano con bottoni. Confezionato a mano, è disponibile in tutte le varianti della cartella tessuti e in tessuto cliente.

TESSUTO OCCORRENTE: cm 50 x 100

Handmade cushion with buttons for sofas. It is available in all fabrics coming from the Morelato sample folder but also customer fabric can be used.

FABRIC NEEDED: cm 50 x 100

ART. A1600065
RULLO



Rullo per il letto, confezionato artigianalmente, imbottito con poliuretano espanso e rivestito in tessuto, è disponibile in tutte le varianti della cartella tessuti e in tessuto cliente.

TESSUTO OCCORRENTE: cm 80 x 140

Handmade bed roll, upholstered with polyurethan foam and covered with fabric. It is available in all fabrics coming from the Morelato sample folder but also customer fabric can be used.

FABRIC NEEDED: cm 80 x 140

COMÒ
CASSETTIERE

COMÒ
CHEST OF DRAWERS



ART. 1203/F
COMO' JOYCE

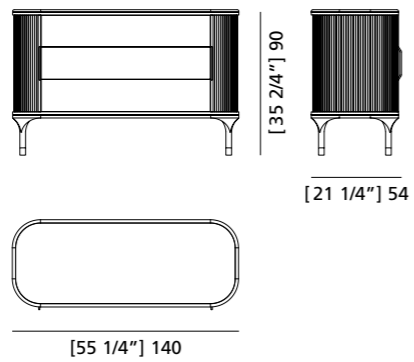

MISURE: L 140 P 54 H 90
DESCRIZIONE: Comò in legno di frassino, tre cassetti a scomparsa e due ante scorrevoli laterali con maniglie in ottone, ripiano interno. Piedino sagomato con bicchierino in ottone. Design Libero Rutilo
PESO: 90 kg - m³: 0,7 - COLLI: 1

MEASURES: L 140 P 54 H 90
DESCRIPTION: Ash wood dresser, three hidden drawers and two side sliding doors with brass handles, internal shelf. Shaped foot with brass cup. Design Libero Rutilo
WEIGHT: 90 kg - m³: 0,7 - PIECES: 1

ART. 1303/F
COMODINO JOYCE

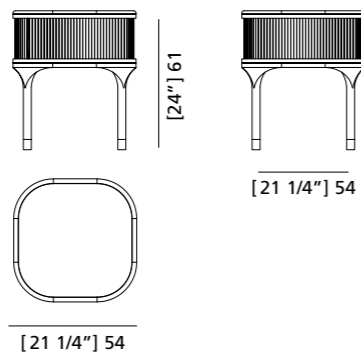

MISURE: L 54 P 54 H 61
DESCRIZIONE: Comodino in legno di frassino, un vano chiuso da antina scorrevole, maniglia in ottone. Piedini sagomati con bicchierino in ottone. Design Libero Rutilo
PESO: 20 kg - m³: 0,2 - COLLI: 1

MEASURES: L 54 P 54 H 61
DESCRIPTION: Ash wood bedside table, a compartment closed by a sliding door, brass handle. Shaped feet with brass cup. Design Libero Rutilo
WEIGHT: 20 kg - m³: 0,2 - PIECES: 1

ART. 1202/F
COMO' BELLAGIO

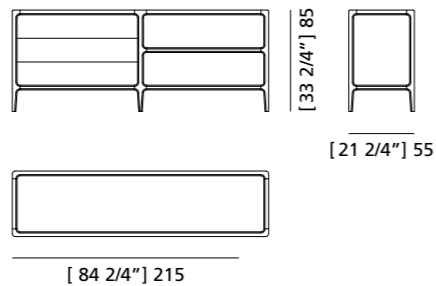

MISURE: L 215 P 55 H 85
DESCRIZIONE: Comò in legno di frassino con 3 cassetti e vano a giorno. Design Libero Rutilo
PESO: 100 kg - m³: 1,0 - COLLI: 1

MEASURES: L 140 P 54 H 90
DESCRIPTION: Chest of drawer made of ash wood with three drawers and open element. Design Libero Rutilo
WEIGHT: 100 kg - m³: 1,0 - PIECES: 1

ART. 1302/F
COMODINO BELLAGIO

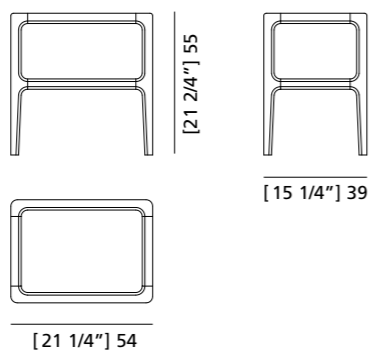

MISURE: L 54 P 39 H 55
DESCRIZIONE: Comodino in legno di frassino con un cassetto. Design Libero Rutilo
PESO: 20 kg - m³: 0,1 - COLLI: 1

MEASURES: L 54 P 39 H 55
DESCRIPTION: Bedside table made of ash wood with one drawer. Top and drawer can be of wood, leather or marble. Design Libero Rutilo
WEIGHT: 20 kg - m³: 0,1 - PIECES: 1

ART. 1201/F
COMO' BELLAGIO

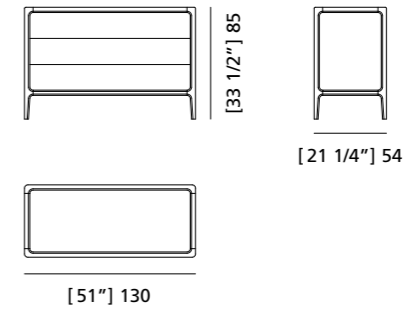

MISURE: L 130 P 54 H 85
DESCRIZIONE: Comò in legno di frassino con tre cassetti. Design: Libero Rutilo
PESO: 80 kg - m³: 0,8 - COLLI: 1

MEASURES: L 130 P 54 H 85
DESCRIPTION: Chest of drawer made of ash wood with three drawers. Design: Libero Rutilo
WEIGHT: 80 kg - m³: 0,8 - PIECES: 1

ART. 1301/F
COMODINO BELLAGIO

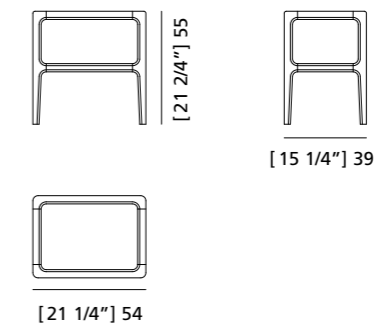

MISURE: L 54 P 39 H 55
DESCRIZIONE: Comodino in legno di frassino con due ripiani in vetro. Design: Libero Rutilo
PESO: 15 kg - m³: 0,15 - COLLI: 1

MEASURES: L 54 P 39 H 55
DESCRIPTION: Bedside table made of ash wood with two glass shelves. Design: Libero Rutilo
WEIGHT: 15 kg - m³: 0,15 - PIECES: 1

ART. 0834/F
CASSETTIERA BELLAGIO

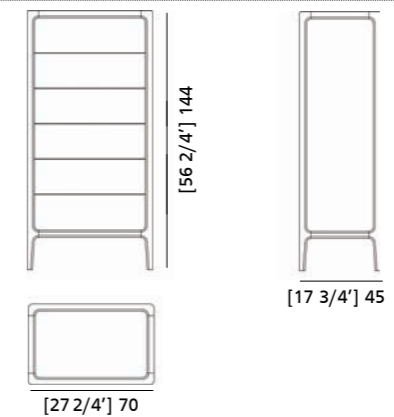
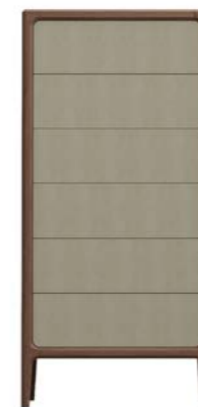

MISURE: L 70 P 45 H 144
DESCRIZIONE: Cassettiera in legno di frassino con sei cassetti. Design: Libero Rutilo
PESO: 50 kg - m³: 0,5 - COLLI: 1

MEASURES: L 70 P 45 H 144
DESCRIPTION: Chest of drawer made of ash wood with six drawers. Design: Libero Rutilo
WEIGHT: 50 kg - m³: 0,5 - PIECES: 1

ART. 0805/F
CASSETTIERA ELLA

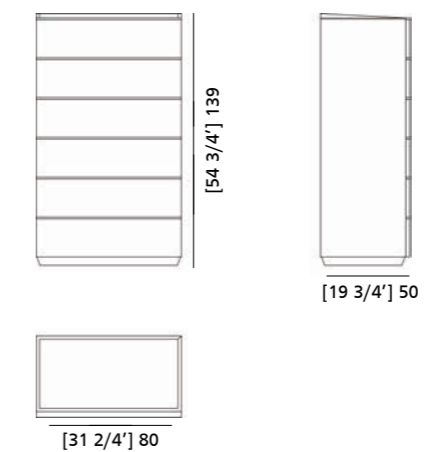

MISURE: L 80 P 50 H 139
DESCRIZIONE: Cassettiera in legno di frassino con sei cassetti su guide estraibili, frontali dei cassetti in vari finiture e colori, piano in pietra. Design Libero Rutilo.
PESO: 55 kg - m³: 0,6 - COLLI: 1

MEASURES: L 80 W 50 H 139
DESCRIPTION: Chest of drawers in ash wood with six drawers on pull-out runners, drawer fronts in various finishes and colors, stone top. Design by Libero Rutilo.
WEIGHT: 55 kg - m³: 0,6 - PIECES: 1

ART. 1205/F
COMO' DUKE

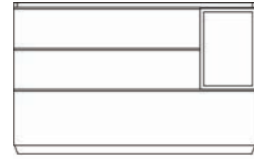

[31 3/4"] 81



[22 2/4"] 57



[51 1/4"] 130

MISURE: L 130 P 57 H 81
DESCRIZIONE: Comò in legno di frassino con un vano a giorno e tre cassetti su guide estraibili, frontali dei cassetti in vari finiture e colori, piano in pietra. Design Libero Rutilo.
PESO: 55 kg - m³: 0,6 - COLLI: 1

MEASURES: L 130 W 57 H 81
DESCRIPTION: Chest of drawers in ash wood with an open compartment and three drawers on pull-out runners, drawer fronts in various finishes and colors, stone top. Design by Libero Rutilo.
WEIGHT: 55 kg - m³: 0,6 - PIECES: 1

ART. 1305/F
COMODINO LOUIS

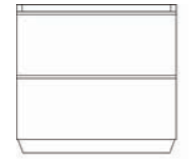

[20 1/4"] 51

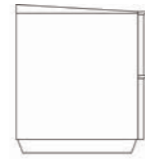

[17 3/4"] 45



[21 3/4"] 55

MISURE: L 55 P 45 H 51
DESCRIZIONE: Comodino in legno di frassino con due cassetti su guide estraibili, frontali dei cassetti in vari finiture e colori, piano in pietra. Design Libero Rutilo.
PESO: 25 kg - m³: 0,15 - COLLI: 1

MEASURES: L 55 W 45 H 51
DESCRIPTION: bedside table in ash wood with two drawers on pull-out runners, drawer fronts in various finishes and colors, stone top. Design by Libero Rutilo.
WEIGHT: 25 kg - m³: 0,15 - PIECES: 1

ART. 1269/F
COMO' ANERIO

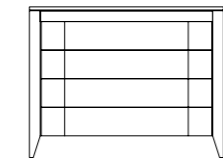

[38 1/4"] 97



[21 2/4"] 55

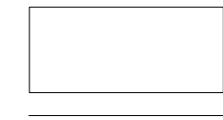

[49 1/4"] 125

MISURE: L 125 P 55 H 97
DESCRIZIONE: comò in legno di frassino a 4 cassetti più 1 cassetto nascosto sotto il piano. Fronte dei cassetti a venatura contrapposta tra parti in rilievo. Design Centro Ricerche MAMM.
PESO: 84 kg - m³: 0,8 - COLLI: 1

MEASURES: L 125 W 55 H 97
DESCRIPTION: chests of drawers made of ash wood with 4 drawers plus 1 hidden drawer under the top. Drawer fronts with opposed grain and different reliefs. Design by centro Ricerche MAMM.
WEIGHT: 84 kg - m³: 0,8 - PIECES: 1

ART. 1366/F
COMODINO ANERIO

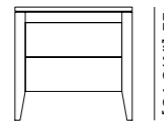

[21 2/4"] 55

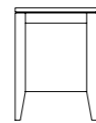

[15 3/4"] 40

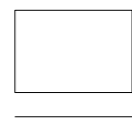

[22 2/4"] 57

MISURE: L 57 P 40 H 55
DESCRIZIONE: comodino in legno di frassino a 2 cassetti. Fronte dei cassetti a venatura contrapposta tra parti in rilievo. Design Centro Ricerche MAMM.
PESO: 24 kg - m³: 0,16 - COLLI: 1

MEASURES: L 57 W 40 H 55
DESCRIPTION: bedside table made of ash wood with 2 drawers. Drawer fronts with opposed grain and different reliefs. Design by centro Ricerche MAMM.
WEIGHT: 24 kg - m³: 0,16 - PIECES: 1

ART. 1268
COMO' VITTORIO NOCE O CILIEGIO

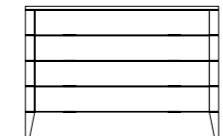

[34 1/4"] 87



[21 2/4"] 55

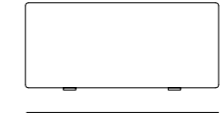

[49 1/4"] 125

MISURE: L 125 P 55 H 87
DESCRIZIONE: comò a 4 cassetti in legno di noce o ciliegio con maniglie in ottone. Gambe a stiletto con particolare fresatura sui fianchi. Su richiesta in legno di noce canaletto. Finitura: F32/C. Design Centro Ricerche MAMM.
PESO: 80 kg - m³: 0,75 - COLLI: 1

MEASURES: L 125 W 55 H 87
DESCRIPTION: chest of drawers made of cherry or walnut wood with brass handles over the 4 drawers. Fine milling on the sides along the drawers cut. Upon request made of walnut. Finishing: F32/C. Design by centro Ricerche MAMM.
WEIGHT: 80 kg - m³: 0,75 - PIECES: 1

ART. 1365
COMODINO VITTORIO NOCE O CILIEGIO



[21 2/4"] 55

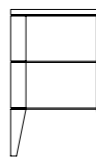

[15 3/4"] 40

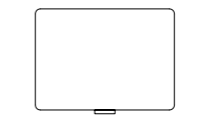

[21 2/4"] 55

MISURE: L 55 P 40 H 55
DESCRIZIONE: comodino a 2 cassetti in legno di noce o ciliegio con maniglie in ottone. Gambe a stiletto con particolare fresatura sui fianchi. Su richiesta in legno di noce canaletto. Finitura: F32/C. Design Centro Ricerche MAMM.
PESO: 24 kg - m³: 0,18 - COLLI: 1

MEASURES: L 55 W 40 H 55
DESCRIPTION: bedside table made of cherry or walnut wood with brass handles over the 2 drawers. Fine milling on the sides along the drawers cut. Upon request made of walnut wood. Finishing: F32/C. Design by centro Ricerche MAMM.
WEIGHT: 24 kg - m³: 0,18 - PIECES: 1

ART. 1204
COMÒ SCACCHI

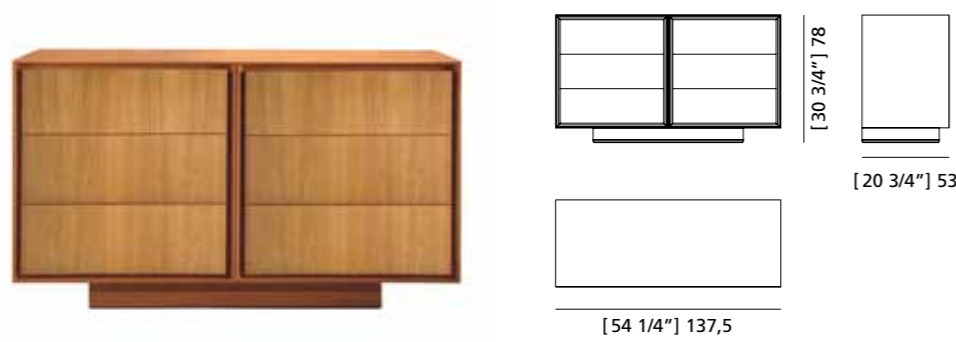

MISURE: L 137,5 P 53 H 78
DESCRIZIONE: Comò a sei cassetti con struttura in legno di ciliegio.
Finitura: F32/C
Design: Centro Ricerche MAM
PESO: 80 kg - m³: 0,60 - COLLI: 1

MEASURES: L 137,5 P 53 H 78
DESCRIPTION: Chest of drawers in cherry wood with 6 drawers.
Finishing: F32/C
Design: Centro Ricerche MAM
WEIGHT: 80 kg - m³: 0,60 - PIECES: 1

ART. 1272/F
COMÒ MALIBÙ

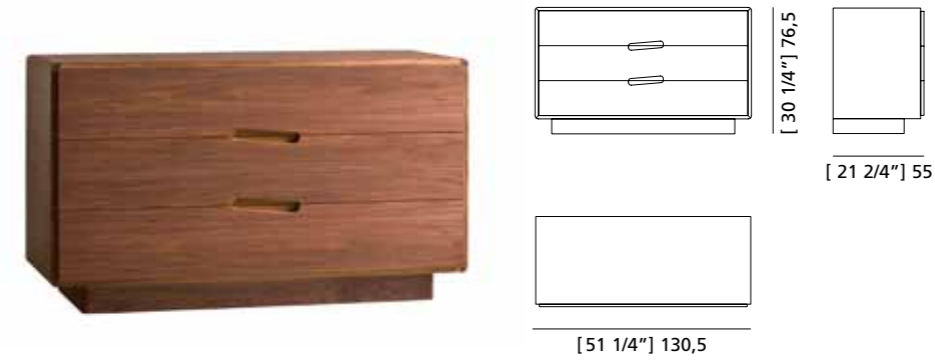

MISURE: L 130,5 P 55 H 76,5
DESCRIZIONE: comò a 3 cassetti in legno di frassino, con guide metalliche. Particolare la struttura ad angoli smussati e le maniglie intagliate in diagonale.
Design Centro Ricerche MAM
PESO: 73 kg - m³: 0,65 - COLLI: 1

MEASURES: L 130,5 W 55 H 76,5
DESCRIPTION: chest of drawers made of ash wood, with 3 drawers on metal runners. Precious structure with rounded corners and diagonally carved handles.
Design by centro Ricerche MAM
WEIGHT: 73 kg - m³: 0,65 - PIECES: 1

ART. 1273
COMÒ FEDELE



MISURE: L 135 P 55 H 82
DESCRIZIONE: Comò a quattro cassetti in legno di ciliegio.
Design Centro Ricerche MAM
PESO: 80 kg - m³: 0,8 - COLLI: 1

MEASURES: L 135 W 55 H 82
DESCRIPTION: Chest of drawer made of cherry wood with four drawers
Design by centro Ricerche MAM
WEIGHT: 80 kg - m³: 0,8 - PIECES: 1

ART. 1367/F
COMODINO MALIBÙ

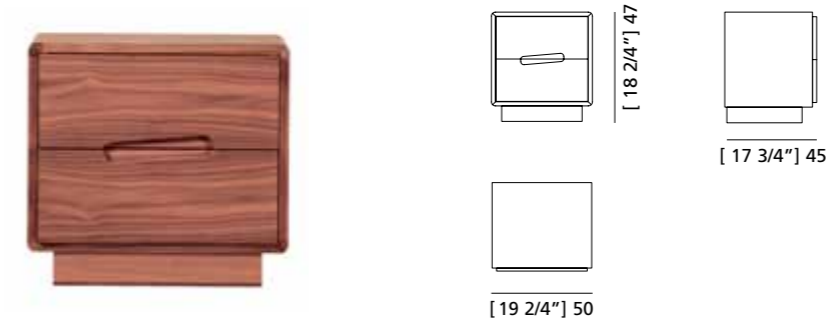

MISURE: L 50 P 45 H 47
DESCRIZIONE: comodino a 2 cassetti in legno di frassino, con guide metalliche. Particolare la struttura ad angoli smussati e le maniglie intagliate in diagonale.
Design Centro Ricerche MAM
PESO: 27 kg - m³: 0,15 - COLLI: 1

MEASURES: L 50 W 45 H 47
DESCRIPTION: bedside table made of ash wood, with 2 drawers on metal runners. Precious structure with rounded corners and diagonally carved handle.
Design by centro Ricerche MAM
WEIGHT: 27 kg - m³: 0,15 - PIECES: 1

ART. 1368
COMODINO FEDELE

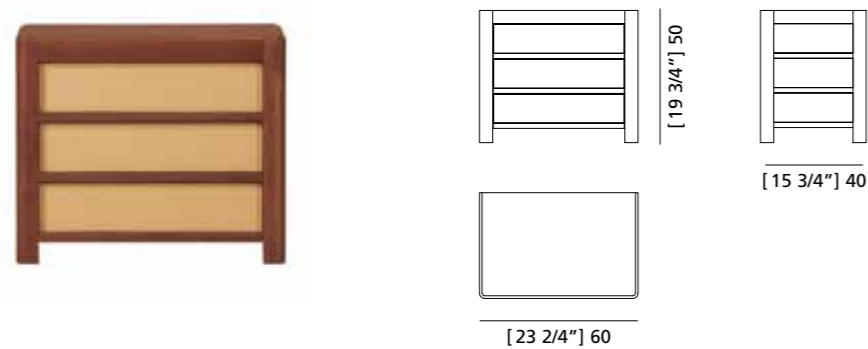

MISURE: L 60 P 40 H 50
DESCRIZIONE: Comodino a tre cassetti in legno di ciliegio con frontali e fianchi rivestiti in pelle.
Design Centro Ricerche MAM
PESO: 25 kg - m³: 0,2 - COLLI: 1

MEASURES: L 60 W 40 H 50
DESCRIPTION: Bedside table made of cherry wood with three drawers and sides covered with leather.
Design by centro Ricerche MAM
WEIGHT: 25 kg - m³: 0,2 - PIECES: 1

ART. 1271
COMÒ NEW YORK



MISURE: L 125 P 54 H 100
DESCRIZIONE: comò a 4 cassetti in legno di ciliegio con gambe a spillo e frontali dei cassetti spioventi, tipica lavorazione della collezione '900. Finitura: F30
Design Centro Ricerche MAM
PESO: 70 kg - m³: 0,8 - COLLI: 1

MEASURES: L 125 W 54 H 100
DESCRIPTION: chest of drawers made of cherry wood with 4 drawers with sloping front, typical processing of the '900 collection. Finishing: F30
Design by centro Ricerche MAM
WEIGHT: 70 kg - m³: 0,8 - PIECES: 1

ART. 1253
COMÒ NEW YORK

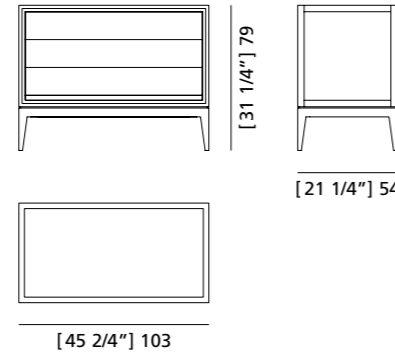

MISURE: L 103 P 54 H 79
DESCRIZIONE: Comò in legno di ciliegio, tre cassetti con frontali spioventi, tipica lavorazione dello stile '900, gambe a spillo. Finitura: F32/C
Design: Centro Ricerche MAM
PESO: 70 kg - m³: 0,50 - COLLI: 1

MEASURES: L 103 P 54 H 79
DESCRIPTION: Chest of drawers made of cherry wood. Finishing F32/C
Design: Centro Ricerche MAM
WEIGHT: 70 kg - m³: 0,50 - PIECES: 1

ART. 1361
COMODINO NEW YORK

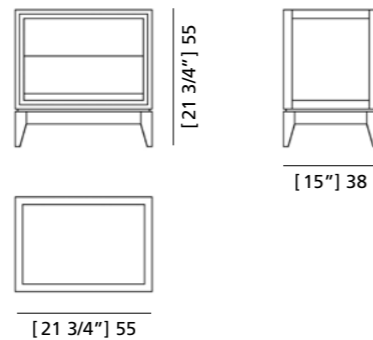

MISURE: L 55 P 38 H 55
DESCRIZIONE: comodino a 2 cassetti in legno di ciliegio con gambe a spillo e frontali dei cassetti spioventi, tipica lavorazione della collezione '900. Finitura: F30
Design Centro Ricerche MAM
PESO: 20 kg - m³: 0,16
COLLI: 1

MEASURES: L 55 W 38 H 55
DESCRIPTION: bedside table made of cherry wood with 2 drawers with sloping front, typical processing of the '900 collection. Finishing: F30
Design by centro Ricerche MAM
WEIGHT: 20 kg - m³: 0,16 - PIECES: 1

ART. 0801
CASSETTIERA NEW YORK

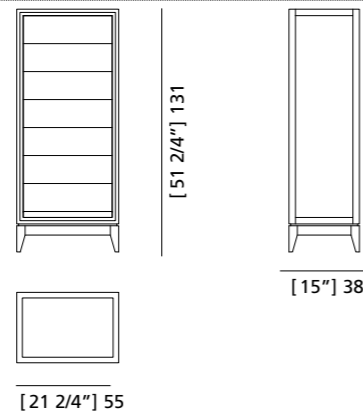

MISURE: L 55 P 38 H 131
DESCRIZIONE: cassetiera a 7 cassetti in legno di ciliegio con gambe a spillo e frontali dei cassetti spioventi, tipica lavorazione della collezione '900. Finitura: F32/C
Design Centro Ricerche MAM
PESO: 30 kg - m³: 0,5 - COLLI: 1

MEASURES: L 55 W 38 H 131
DESCRIPTION: chest of drawers made of cherry wood with 7 drawers with sloping front, typical processing of the '900 collection. Finishing: F32/C
Design by centro Ricerche MAM
WEIGHT: 30 kg - m³: 0,5 - PIECES: 1

ART. 1257
COMÒ RULMAN

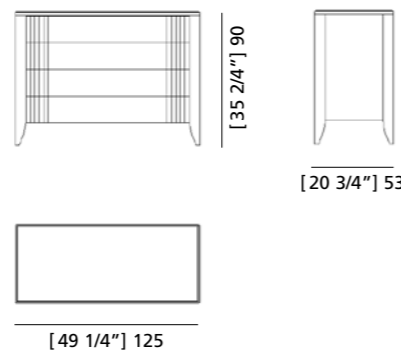

MISURE: L 125 P 53 H 90
DESCRIZIONE: Comò a 4 cassetti in legno di ciliegio con pregiata venatura e controfresatura a lesene sui lati dei cassetti. Finitura: F60
Design Centro Ricerche MAM
PESO: 77 kg - m³: 0,78 - COLLI: 1

MEASURES: L 125 W 53 H 90
DESCRIPTION: Chest of drawers made of cherry wood with prestigious veneer on the surfaces and fine milling on the drawers sides. Finishing: F60
Design by centro Ricerche MAM
WEIGHT: 77 kg - m³: 0,78 - PIECES: 1

ART. 1356
COMODINO RULMAN

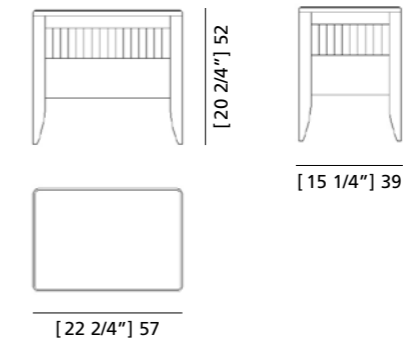

MISURE: L 57 P 39 H 52
DESCRIZIONE: comodino a 2 cassetti in legno di ciliegio con pregiata venatura e controfresatura a lesene sul cassetto superiore. Finitura: F60
Design Centro Ricerche MAM
PESO: 22 kg - m³: 0,16 - COLLI: 1

MEASURES: L 57 W 39 H 52
DESCRIPTION: bedside table made of cherry wood with prestigious veneer on the surfaces and fine milling on the upper drawer. Finishing: F60
Design by centro Ricerche MAM
WEIGHT: 22 kg - m³: 0,16 - PIECES: 1

ART. 0831
CASSETTIERA BIEDERMEIER

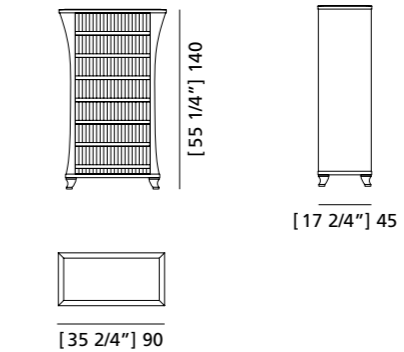

MISURE: L 90 P 45 H 140
DESCRIZIONE: comò in legno di ciliegio con fresatura a lesene sui 7 cassetti e pregiato intarsio in ebano. Finitura: F34
Design Centro Ricerche MAM
PESO: 75 kg - m³: 0,7 - COLLI: 1

MEASURES: L 90 W 45 H 140
DESCRIPTION: chest of drawers made of cherry wood with prestigious milling on the 7 drawers and ebony inlay. Finishing: F34
Design by centro Ricerche MAM
WEIGHT: 75 kg - m³: 0,7 - PIECES: 1

ART. 1258
COMÒ BIEDERMEIER

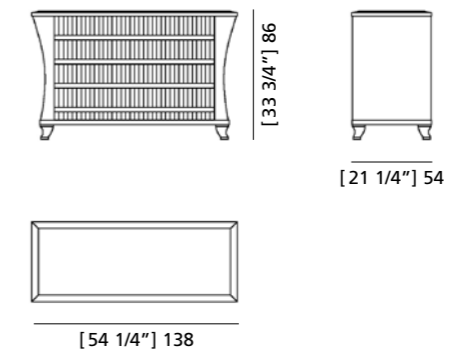

MISURE: L 138 P 54 H 86
DESCRIZIONE: comò in legno di ciliegio con fresatura a lesene sui 4 cassetti e pregiato intarsio in ebano. Finitura: F34
Design Centro Ricerche MAM
PESO: 90 kg - m³: 0,84 - COLLI: 1

MEASURES: L 138 W 54 H 86
DESCRIPTION: chest of drawers made of cherry wood with prestigious milling on the 4 drawers and ebony inlay. Finishing: F34
Design by centro Ricerche MAM
WEIGHT: 90 kg - m³: 0,84 - PIECES: 1

ART. 1362
COMODINO BIEDERMEIER

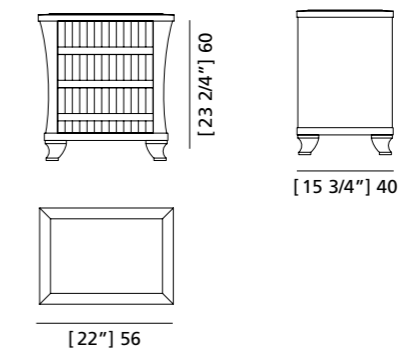

MISURE: L 56 P 40 H 60
DESCRIZIONE: comodino in legno di ciliegio con fresatura a lesene sui 3 cassetti e pregiato intarsio in ebano. Finitura: F34
Design Centro Ricerche MAM
PESO: 26 kg - m³: 0,17 - COLLI: 1

MEASURES: L 56 W 40 H 60
DESCRIPTION: bedside table made of cherry wood with prestigious milling on the 3 drawers and ebony inlay. Finishing: F34
Design by centro Ricerche MAM
WEIGHT: 26 kg - m³: 0,17 - PIECES: 1

ART. 1243
COMÒ DIRETTORIO



MISURE: L 125 P 54 H 100
DESCRIZIONE: Comò a 5 cassetti in legno di ciliegio. 3 cassetti con maniglie e 2 a scomparsa sotto il piano.
Design Centro Ricerche MAM
PESO: 72 kg - m³: 0,8 - **COLLI:** 1

MEASURES: L 125 W 54 H 100
DESCRIPTION: chest of drawers made of cherry wood with 3 big drawers and 2 small hidden drawers under the top. Fine milling on the sides and carved legs.
Design by centro Ricerche MAM
WEIGHT: 72 kg - m³: 0,8 - **PIECES:** 1

ART. 1348
COMODINO DIRETTORIO



MISURE: L 54 P 38 H 64
DESCRIZIONE: comodino a 3 cassetti in legno di ciliegio. 2 cassetti con maniglie e 1 a scomparsa sotto il piano.
Design Centro Ricerche MAM
PESO: 22 kg - m³: 0,15 - **COLLI:** 1

MEASURES: L 54 W 38 H 64
DESCRIPTION: Bedside table made of cherry wood with 3 drawers. Fine milling on the sides and carved legs.
Design by centro Ricerche MAM
WEIGHT: 22 kg - m³: 0,15 - **PIECES:** 1

CABINE ARMADIO

WARDROBE CABINS



ART. 3674/F
MODULO SWING

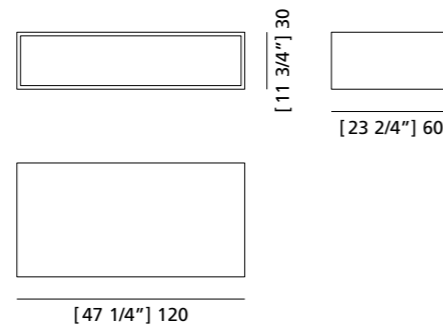

MISURE: L 120 P 60 H 30
DESCRIZIONE: Modulo a giorno in legno di frassino.
Design Libero Rutilo

MEASURES: L 120 P 60 H 30
DESCRIPTION: Swing modular open element made of ash wood.
Design Libero Rutilo

ART. 3678/F
MODULO SWING

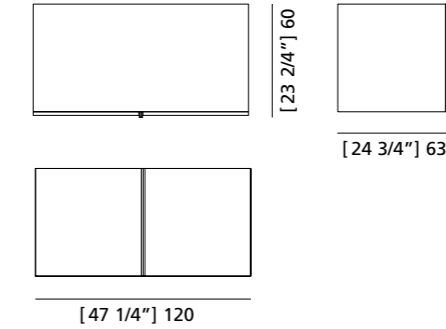

MISURE: L 120 P 63 H 60
DESCRIZIONE: Modulo in legno di frassino con due ante a battente, un ripiano interno.
Design Libero Rutilo

MEASURES: L 120 P 63 H 60
DESCRIPTION: Swing modular element with two doors made of ash wood.
Design Libero Rutilo

ART. 3675/F
MODULO SWING CON CASSETTO

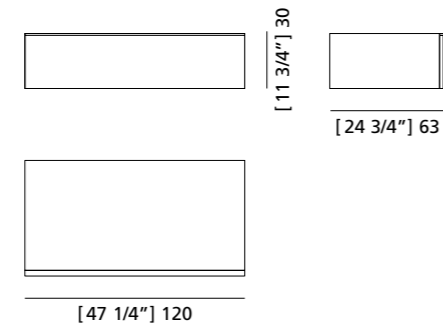

MISURE: L 120 P 63 H 30
DESCRIZIONE: Modulo in legno di frassino con un cassetto.
Design Libero Rutilo

MEASURES: L 120 P 63 H 30
DESCRIPTION: Swing modular element made of ash wood with drawer.
Design Libero Rutilo

ART. 3679/F
MODULO SWING

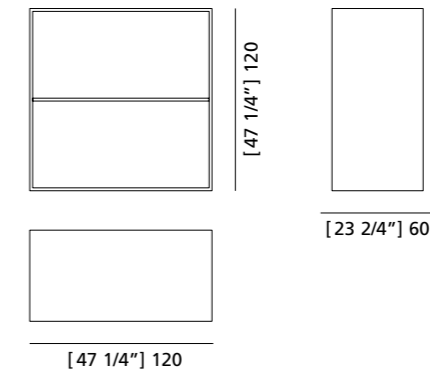

MISURE: L 120 P 60 H 120
DESCRIZIONE: Modulo a giorno in legno di frassino, un ripiano interno.
Design Libero Rutilo

MEASURES: L 120 P 60 H 120
DESCRIPTION: Swing modular open element made of ash wood.
Design Libero Rutilo

ART. 3676/F
MODULO SWING

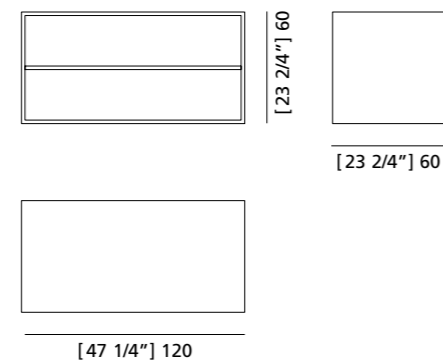

MISURE: L 120 P 60 H 60
DESCRIZIONE: Modulo a giorno in legno di frassino, un ripiano interno.
Design Libero Rutilo

MEASURES: L 120 P 60 H 60
DESCRIPTION: Swing modular open element made of ash wood.
Design Libero Rutilo

ART. 3680/F
MODULO SWING

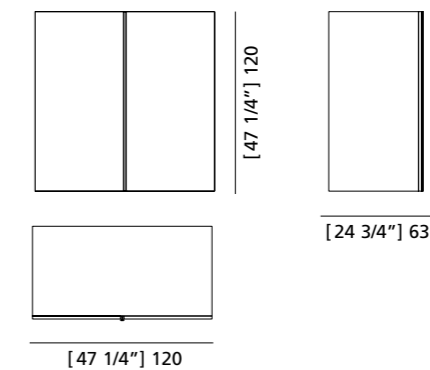

MISURE: L 120 P 63 H 120
DESCRIZIONE: Modulo in legno di frassino con due ante a battente, un ripiano interno.
Design Libero Rutilo

MEASURES: L 120 P 63 H 120
DESCRIPTION: Swing modular element with two doors made of ash wood.
Design Libero Rutilo

ART. 3677/F
MODULO SWING CON CASSETTI

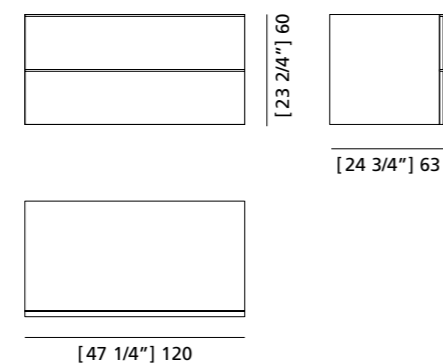

MISURE: L 120 P 63 H 60
DESCRIZIONE: Modulo in legno di frassino con due cassetti.
Design Libero Rutilo

MEASURES: L 120 P 63 H 60
DESCRIPTION: Swing modular element made of ash wood with 2 drawers.
Design Libero Rutilo

ART. 3681/F
MODULO SWING

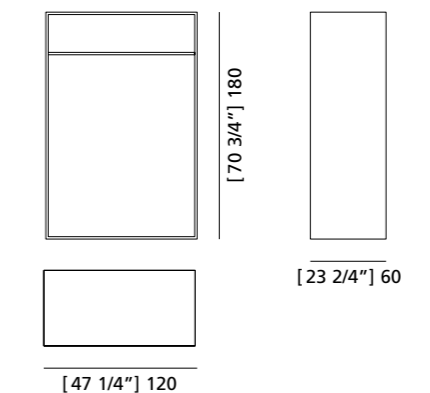

MISURE: L 120 P 60 H 180
DESCRIZIONE: Modulo a giorno in legno di frassino, un ripiano interno.
Design Libero Rutilo

MEASURES: L 120 P 60 H 180
DESCRIPTION: Swing modular open element made of ash wood.
Design Libero Rutilo

ART. 3682/F
MODULO SWING

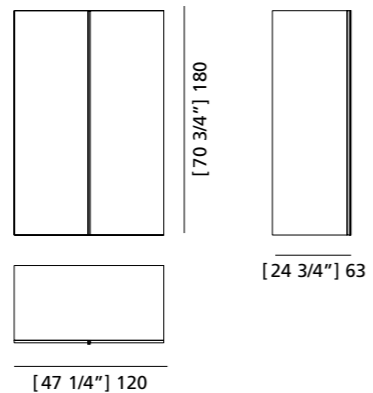

MISURE: L 120 P 63 H 180
DESCRIZIONE: Modulo in legno di frassino con due ante a battente, un ripiano interno.
Design Libero Rutilo

MEASURES: L 120 P 63 H 180
DESCRIPTION: Swing modular element with two doors made of ash wood.
Design Libero Rutilo

ART. 3683/F
MODULO SWING

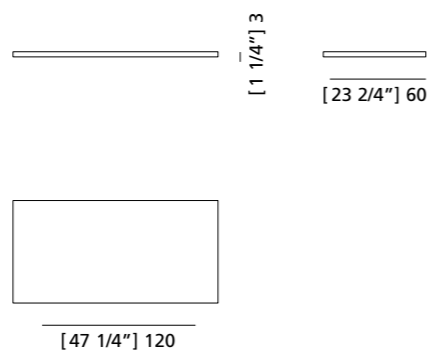

MISURE: L 120 P 60 H 3
DESCRIZIONE: Ripiano in legno di frassino. Finitura F32/F.
Design Libero Rutilo

MEASURES: L 120 P 60 H 3
DESCRIPTION: Wooden shelf.
Design Libero Rutilo

ART. 3673/F
MODULO SWING

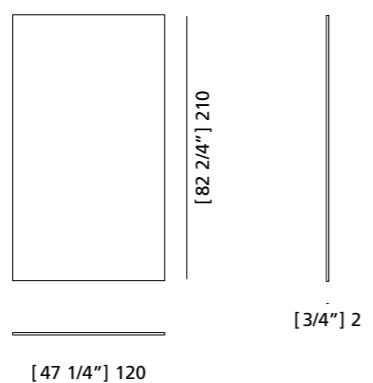

MISURE: L 120 P 2 H 210
DESCRIZIONE: Pannello boiserie in legno di frassino.
Design Libero Rutilo

MEASURES: L 120 P 2 H 210
DESCRIPTION: Boiserie panel in ash wood.
Design Libero Rutilo



ART. 0395
MODULO GUARDAROBA PRESIDENT

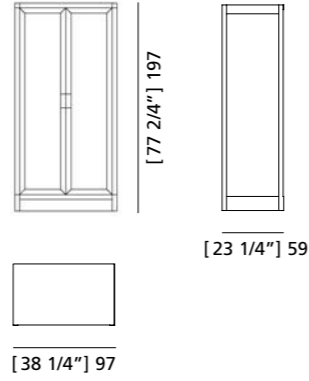

MISURE: L 97 P 59 H 197
DESCRIZIONE: Modulo per cabina armadio, struttura in legno di ciliegio, due ante a battente in legno, ripiano interno e paletto appendiabiti. Finitura: F32/C Design: Centro Ricerche
PESO: 80 kg - m³: 1,20 - **COLLI:** 2

MEASURES: L 97 P 59 H 197
DESCRIPTION: President modular element in cherry wood with 2 doors 1 shelf and clothes rail. Finishing: F32/C Design: Centro Ricerche
WEIGHT: 80 kg - m³: 1,20 - **PIECES:** 2

ART. 0399
CORNICE AL METRO LINEARE

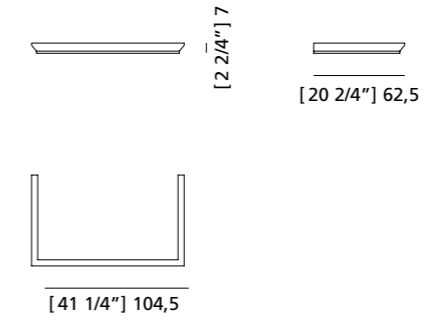

MISURE: L 104,5 P 62,5 H 7
DESCRIZIONE: Cornice in legno di ciliegio per modulo cabina armadio. Finitura: F32/C Design: Centro Ricerche
PESO: 80 kg - m³: 1,20 - **COLLI:** 2

MEASURES: L 104,5 P 62,5 H 7
DESCRIPTION: Wooden frame for president modular elements. Finishing: F32/C Design: Centro Ricerche
WEIGHT: 80 kg - m³: 1,20 - **PIECES:** 2

ART. 0396
MODULO GUARDAROBA PRESIDENT

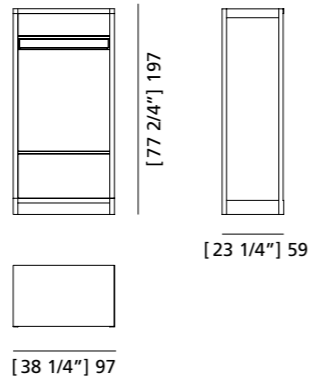

MISURE: L 97 P 59 H 197
DESCRIZIONE: Modulo per cabina armadio, struttura a giorno in legno di ciliegio, ripiano interno e paletto appendiabiti. Finitura: F32/C Design: Centro Ricerche
PESO: 70 kg - m³: 1,20 - **COLLI:** 2

MEASURES: L 97 P 59 H 197
DESCRIPTION: President modular open element in cherry wood with 2 shelves and clothes rail. Finishing: F32/C Design: Centro Ricerche
WEIGHT: 70 kg - m³: 1,20 - **PIECES:** 2

ART. 0397
MODULO GUARDAROBA PRESIDENT

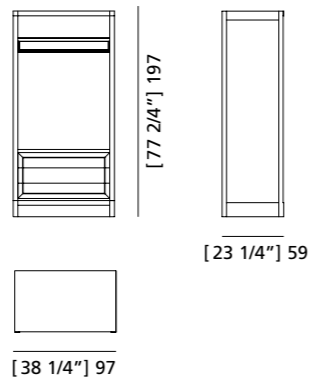

MISURE: L 97 P 59 H 197
DESCRIZIONE: Modulo per cabina armadio, struttura in legno di ciliegio, ripiano interno e cassetiera a tre cassetti. Finitura: F32/C Design: Centro Ricerche
PESO: 95 kg - m³: 1,20 - **COLLI:** 2

MEASURES: L 97 P 59 H 197
DESCRIPTION: President modular open element in cherry wood with 3 drawers, 1 shelf and clothes rail. Finishing: F32/C Design: Centro Ricerche
WEIGHT: 95 kg - m³: 1,20 - **PIECES:** 2

ART. 0398
MODULO GUARDAROBA PRESIDENT

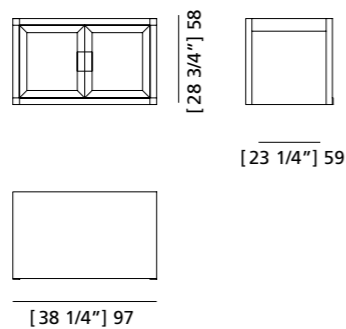

MISURE: L 97 P 59 H 58
DESCRIZIONE: Modulo sopralzo per cabina armadio, struttura in legno di ciliegio, due ante a battente in legno. Finitura: F32/C Design: Centro Ricerche
PESO: 30 kg - m³: 0,30 - **COLLI:** 1

MEASURES: L 97 P 59 H 58
DESCRIPTION: President modular upper element with 2 doors. Finishing: F32/C Design: Centro Ricerche
WEIGHT: 30 kg - m³: 0,30 - **PIECES:** 1

ARMADI

WARDROBES



ART. 0362
GUARDAROBA '900

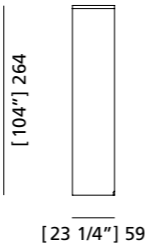
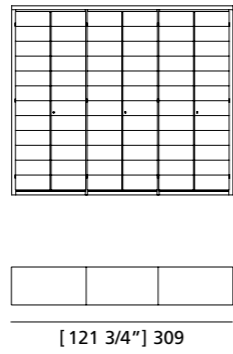

[121 3/4"] 309

MISURE: L 309 P 59 H 264
DESCRIZIONE: armadio guardaroba a 6 ante in legno di ciliegio con pregiata impiallacciatura a venature disallineate. Interno: 5 ripiani regolabili e 5 aste appendiabiti. Accessori su richiesta: cassettiera a 3 cassetti, portacravatte, portapantaloni, cassaforte, appendiabiti inclinabile, specchio. Finitura: F30 Design Centro Ricerche MAMM
PESO: 330 kg - m³: 1,8 - **COLLI:** 10

MEASURES: L 309 W 59 H 264
DESCRIPTION: wardrobe with 6 doors made of cherry wood with a fine grain misalignment. Inside: 5 adjustable shelves and 5 clothes rails. Accessories on request: chest of 3 drawers, tie rack, trouser rack, electronic safe, lifting hanging, rail mirror. Finishing: F30 Design by centro Ricerche MAMM
WEIGHT: 330 kg - m³: 1,8 - **PIECES:** 10

ART. 0366
GUARDAROBA '900

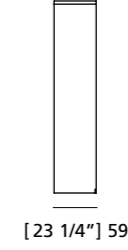
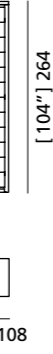

[42 2/4"] 108

MISURE: L 108 P 59 H 264
DESCRIZIONE: armadio guardaroba a 2 ante in legno di ciliegio con pregiata impiallacciatura a venature disallineate. Interno: 2 ripiani regolabili e 2 aste appendiabiti. Accessori su richiesta: cassettiera a 3 cassetti, portacravatte, portapantaloni, cassaforte, appendiabiti inclinabile, specchio. Finitura: F30 Design Centro Ricerche MAMM
PESO: 185 kg - m³: 1 - **COLLI:** 6

MEASURES: L 108 W 59 H 264
DESCRIPTION: wardrobe with 2 doors made of cherry wood with a fine grain misalignment. Inside: 2 adjustable shelves and 2 clothes rails. Accessories on request: chest of 3 drawers, tie rack, trouser rack, electronic safe, lifting hanging, rail mirror. Finishing: F30 Design by centro Ricerche MAMM
WEIGHT: 185 kg - m³: 1 - **PIECES:** 6

ART. 0363
GUARDAROBA '900

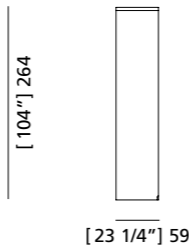
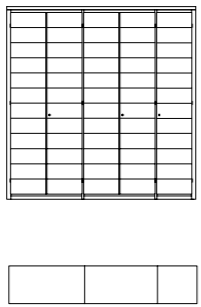

[102 1/4"] 260

MISURE: L 260 P 59 H 264
DESCRIZIONE: armadio guardaroba a 5 ante in legno di ciliegio con pregiata impiallacciatura a venature disallineate. Interno: 5 ripiani regolabili e 5 aste appendiabiti. Accessori su richiesta: cassettiera a 3 cassetti, portacravatte, portapantaloni, cassaforte, appendiabiti inclinabile, specchio. Finitura: F30 Design Centro Ricerche MAMM
PESO: 295 kg - m³: 1,7 - **COLLI:** 9

MEASURES: L 260 W 59 H 264
DESCRIPTION: wardrobe with 5 doors made of cherry wood with a fine grain misalignment. Inside: 5 adjustable shelves and 5 clothes rails. Accessories on request: chest of 3 drawers, tie rack, trouser rack, electronic safe, lifting hanging, rail mirror. Finishing: F30 Design by centro Ricerche MAMM
WEIGHT: 295 kg - m³: 1,7 - **PIECES:** 9

ART. 0371
GUARDAROBA '900

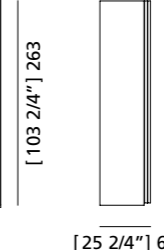
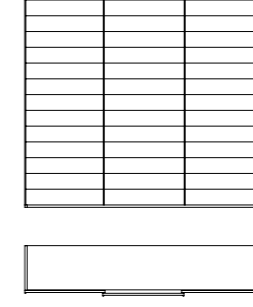

[119 1/4"] 303

MISURE: L 303 P 65 H 263
DESCRIZIONE: armadio guardaroba a 3 ante scorrevoli in legno di ciliegio con pregiata impiallacciatura a venature disallineate. Interno: 5 ripiani regolabili e 5 aste appendiabiti. Accessori su richiesta: cassettiera a 3 cassetti, portacravatte, portapantaloni, cassaforte, appendiabiti inclinabile, specchio. Finitura: F32/C Design Centro Ricerche MAMM
PESO: 330 kg - m³: 1,8 - **COLLI:** 9

MEASURES: L 303 W 65 H 263
DESCRIPTION: wardrobe with 3 sliding doors made of cherry wood with a fine grain misalignment. Inside: 5 adjustable shelves and 5 clothes rails. Accessories on request: chest of 3 drawers, tie rack, trouser rack, electronic safe, lifting hanging, rail mirror. Finishing: F32/C Design by centro Ricerche MAMM
WEIGHT: 330 kg - m³: 1,8 - **PIECES:** 9

ART. 0364
GUARDAROBA '900

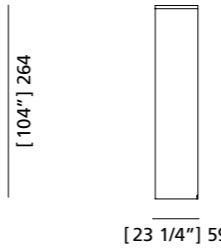
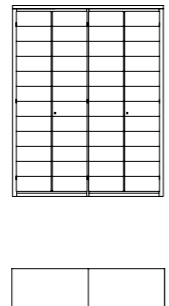

[82 3/4"] 210

MISURE: L 210 P 59 H 264
DESCRIZIONE: armadio guardaroba a 4 ante in legno di ciliegio con pregiata impiallacciatura a venature disallineate. Interno: 4 ripiani regolabili e 4 aste appendiabiti. Accessori su richiesta: cassettiera a 3 cassetti, portacravatte, portapantaloni, cassaforte, appendiabiti inclinabile, specchio. Finitura: F30 Design Centro Ricerche MAMM
PESO: 265 kg - m³: 1,5 - **COLLI:** 8

MEASURES: L 210 W 59 H 264
DESCRIPTION: wardrobe with 4 doors made of cherry wood with a fine grain misalignment. Inside: 4 adjustable shelves and 4 clothes rails. Accessories on request: chest of 3 drawers, tie rack, trouser rack, electronic safe, lifting hanging, rail mirror. Finishing: F30 Design by centro Ricerche MAMM
WEIGHT: 265 kg - m³: 1,5 - **PIECES:** 8

ART. 0365
GUARDAROBA '900

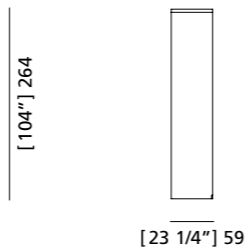
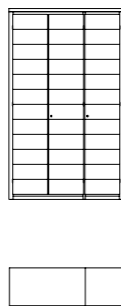

[62 2/4"] 159

MISURE: L 159 P 59 H 264
DESCRIZIONE: armadio guardaroba a 3 ante in legno di ciliegio con pregiata impiallacciatura a venature disallineate. Interno: 4 ripiani regolabili e 4 aste appendiabiti. Accessori su richiesta: cassettiera a 3 cassetti, portacravatte, portapantaloni, cassaforte, appendiabiti inclinabile, specchio. Finitura: F30 Design Centro Ricerche MAMM
PESO: 225 kg - m³: 1,2 - **COLLI:** 8

MEASURES: L 159 W 59 H 264
DESCRIPTION: wardrobe with 3 doors made of cherry wood with a fine grain misalignment. Inside: 4 adjustable shelves and 4 clothes rails. Accessories on request: chest of 3 drawers, tie rack, trouser rack, electronic safe, lifting hanging, rail mirror. Finishing: F30 Design by centro Ricerche MAMM
WEIGHT: 225 kg - m³: 1,2 - **PIECES:** 8

ART. 0327
GUARDAROBA SCACCHI

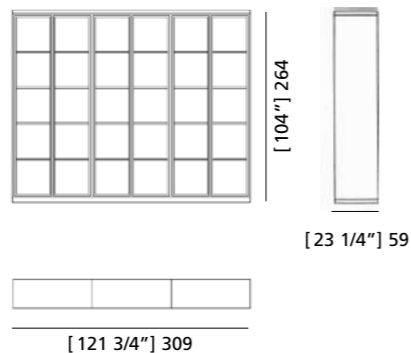

MISURE: L 309 P 59 H 264
DESCRIZIONE: armadio guardaroba a 6 ante in legno di ciliegio con pregiata lavorazione a "scacchiera" e impiallacciatura a venature contrapposte. Interno: 5 ripiani regolabili e 5 aste appendiabiti. Accessori su richiesta: cassetiera a 3 cassetti, portacravatte, portapantaloni, cassaforte, appendiabiti inclinabile, specchio. Finitura: F30 Design Centro Ricerche MAMM
PESO: 330 kg - m³: 1,8 - COLLI: 10

MEASURES: L 309 W 59 H 264
DESCRIPTION: wardrobe with 6 doors made of cherry wood with a fine checkerboard decoration. Inside: 5 adjustable shelves and 5 clothes rails. Accessories on request: chest of 3 drawers, tie rack, trouser rack, electronic safe, lifting hanging, rail mirror. Finishing: F30. Design by centro Ricerche MAMM
WEIGHT: 330 kg - m³: 1,8 - PIECES: 10

ART. 0331
GUARDAROBA SCACCHI

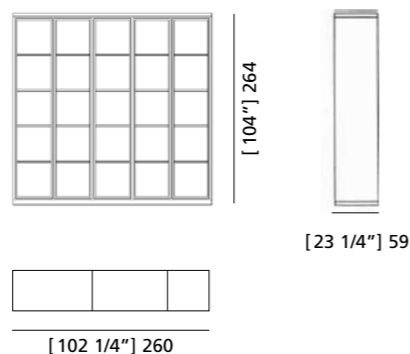

MISURE: L 260 P 59 H 264
DESCRIZIONE: armadio guardaroba a 5 ante in legno di ciliegio con pregiata lavorazione a "scacchiera" e impiallacciatura a venature contrapposte. Interno: 5 ripiani regolabili e 5 aste appendiabiti. Accessori su richiesta: cassetiera a 3 cassetti, portacravatte, portapantaloni, cassaforte, appendiabiti inclinabile, specchio. Finitura: F30- Design Centro Ricerche MAMM
PESO: 295 kg - m³: 1,7 - COLLI: 9

MEASURES: L 260 W 59 H 264
DESCRIPTION: Wardrobe with 5 doors made of cherry wood with a fine checkerboard decoration. Inside: 5 adjustable shelves and 5 clothes rails. Accessories on request: chest of 3 drawers, tie rack, trouser rack, electronic safe, lifting hanging, rail mirror. Finishing: F30. Design by centro Ricerche MAMM
WEIGHT: 295 kg - m³: 1,7 - PIECES: 9

ART. 0332
GUARDAROBA SCACCHI

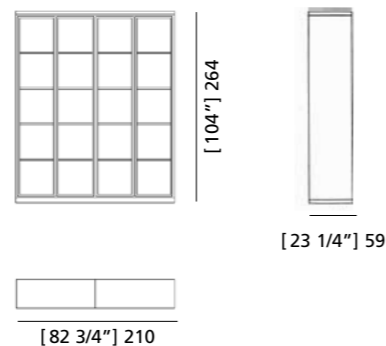

MISURE: L 210 P 59 H 264
DESCRIZIONE: armadio guardaroba a 4 ante in legno di ciliegio con pregiata lavorazione a "scacchiera" e impiallacciatura a venature contrapposte. Interno: 4 ripiani regolabili e 4 aste appendiabiti. Accessori su richiesta: cassetiera a 3 cassetti, portacravatte, portapantaloni, cassaforte, appendiabiti inclinabile, specchio. Finitura: F30 Design Centro Ricerche MAMM
PESO: 275 kg - m³: 1,5 - COLLI: 8

MEASURES: L 210 W 59 H 264
DESCRIPTION: wardrobe with 4 doors made of cherry wood with a fine checkerboard decoration. Inside: 4 adjustable shelves and 4 clothes rails. Accessories on request: chest of 3 drawers, tie rack, trouser rack, electronic safe, lifting hanging, rail mirror. Finishing: F30 Design by centro Ricerche MAMM
WEIGHT: 275 kg - m³: 1,5 - PIECES: 8

ART. 0349
GUARDAROBA SCACCHI

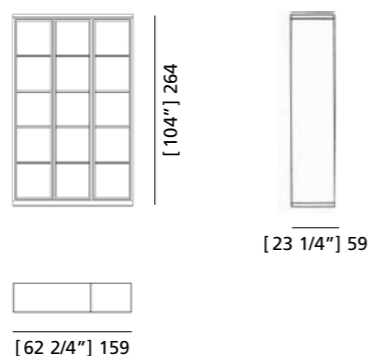

MISURE: L 159 P 59 H 264
DESCRIZIONE: armadio guardaroba a 3 ante in legno di ciliegio con pregiata lavorazione a "scacchiera" e impiallacciatura a venature contrapposte. Interno: 4 ripiani regolabili e 4 aste appendiabiti. Accessori su richiesta: cassetiera a 3 cassetti, portacravatte, portapantaloni, cassaforte, appendiabiti inclinabile, specchio. Finitura: F30 Design Centro Ricerche MAMM
PESO: 225 kg - m³: 1,2 - COLLI: 8

MEASURES: L 159 W 59 H 264
DESCRIPTION: wardrobe with 3 doors made of cherry wood with a fine checkerboard decoration. Inside: 4 adjustable shelves and 4 clothes rails. Accessories on request: chest of 3 drawers, tie rack, trouser rack, electronic safe, lifting hanging, rail mirror. Finishing: F30 Design by centro Ricerche MAMM
WEIGHT: 225 kg - m³: 1,2 - PIECES: 8

ART. 0348
GUARDAROBA SCACCHI

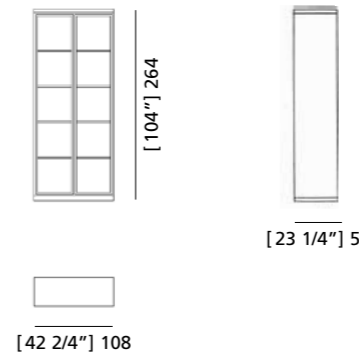

MISURE: L 108 P 59 H 264
DESCRIZIONE: Armadio guardaroba a 2 ante in legno di ciliegio con pregiata lavorazione a "scacchiera" e impiallacciatura a venature contrapposte. Interno: 2 ripiani regolabili e 2 aste appendiabiti. Accessori su richiesta: cassetiera a 3 cassetti, portacravatte, portapantaloni, cassaforte, appendiabiti inclinabile, specchio. Finitura: F30 Design Centro Ricerche MAMM
PESO: 170 kg - m³: 1 - COLLI: 6

MEASURES: L 108 W 59 H 264
DESCRIPTION: Wardrobe with 2 doors made of cherry wood with a fine checkerboard decoration. Inside: 2 adjustable shelves and 2 clothes rails. Accessories on request: chest of 3 drawers, tie rack, trouser rack, electronic safe, lifting hanging, rail mirror. Finishing: F30. Design by centro Ricerche MAMM
WEIGHT: 170 kg - m³: 1 - PIECES: 6

ART. 0372
GUARDAROBA SCACCHI

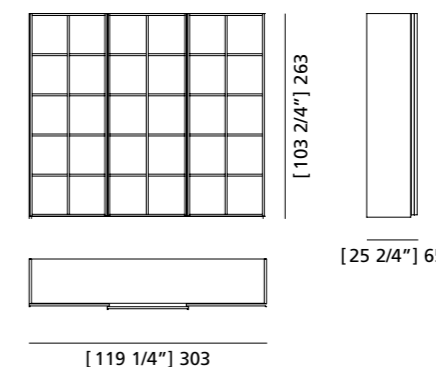

MISURE: L 303 P 65 H 263
DESCRIZIONE: armadio guardaroba a 3 ante scorrevoli in legno di ciliegio con pregiata lavorazione a "scacchiera" e impiallacciatura a venature contrapposte. Interno: 5 ripiani regolabili e 5 aste appendiabiti. Accessori su richiesta: cassetiera a 3 cassetti, portacravatte, portapantaloni, cassaforte, appendiabiti inclinabile, specchio. Finitura: F32/C Design Centro Ricerche MAMM
PESO: 330 kg - m³: 1,8 - COLLI: 9

MEASURES: L 303 W 65 H 263
DESCRIPTION: wardrobe with 3 sliding doors made of cherry wood with a fine checkerboard decoration. Inside: 5 adjustable shelves and 5 clothes rails. Accessories on request: chest of 3 drawers, tie rack, trouser rack, electronic safe, lifting hanging, rail mirror. Finishing: F32/C Design by centro Ricerche MAMM
WEIGHT: 330 kg - m³: 1,8 - PIECES: 9

ART. 0374
GUARDARоба DIRETTORIO

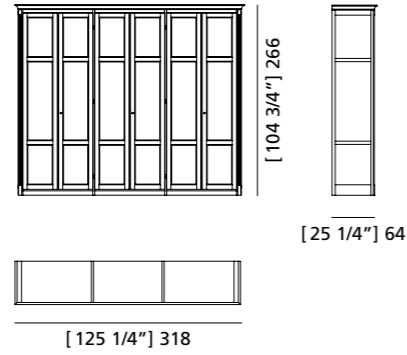

MISURE: L 318 P 64 H 266
DESCRIZIONE: Armadio guardaroba a 6 ante in legno di ciliegio con pregiata fresatura sui fianchi e cornice di chiusura. Interno: 5 ripiani regolabili e 5 aste appendiabiti. Accessori su richiesta: cassetiera a 3 cassetti, portacravatte, portapantaloni, cassaforte, appendiabiti inclinabile, specchio. Finitura: F34 Design Centro Ricerche MAMM
PESO: 300 kg - m³: 1,8 - COLLI: 10

MEASURES: L 318 W 64 H 266
DESCRIPTION: Wardrobe with 6 doors made of cherry wood with a fine milling on the sides and decorating frame. Inside: 5 adjustable shelves and 5 clothes rails. Accessories on request: chest of 3 drawers, tie rack, trouser rack, electronic safe, lifting hanging, rail mirror. Finishing: F34 Design by centro Ricerche MAMM
WEIGHT: 300 kg - m³: 1,8 - PIECES: 10

ART. 0375
GUARDARоба DIRETTORIO

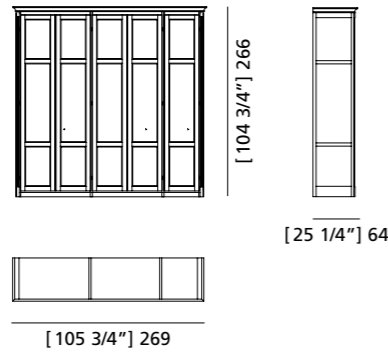

MISURE: L 269 P 64 H 266
DESCRIZIONE: armadio guardaroba a 5 ante in legno di ciliegio con pregiata fresatura sui fianchi e cornice di chiusura. Interno: 5 ripiani regolabili e 5 aste appendiabiti. Accessori su richiesta: cassetiera a 3 cassetti, portacravatte, portapantaloni, cassaforte, appendiabiti inclinabile, specchio. Finitura: F34 Design Centro Ricerche MAMM
PESO: 280 kg - m³: 1,7 - COLLI: 9

MEASURES: L 269 W 64 H 266
DESCRIPTION: wardrobe with 5 doors made of cherry wood with a fine milling on the sides and decorating frame. Inside: 1 chest of 3 drawers, 5 adjustable shelves and 5 clothes rails. Accessories on request: tie rack, trouser rack, electronic safe, lifting hanging, rail mirror. Finishing: F34. Design by centro Ricerche MAMM
WEIGHT: 280 kg - m³: 1,7 - PIECES: 9

ART. 0376
GUARDARоба DIRETTORIO

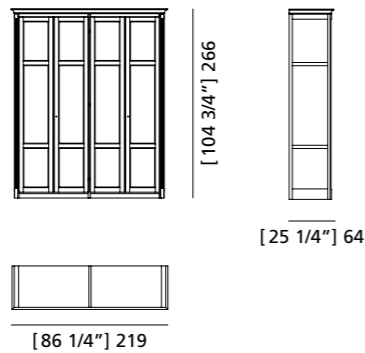

MISURE: L 219 P 64 H 266
DESCRIZIONE: Armadio guardaroba a 4 ante in legno di ciliegio con pregiata fresatura sui fianchi e cornice di chiusura. Interno: 4 ripiani regolabili e 4 aste appendiabiti. Accessori su richiesta: cassetiera a 3 cassetti, portacravatte, portapantaloni, cassaforte, appendiabiti inclinabile, specchio. Finitura: F34 Design Centro Ricerche MAMM
PESO: 255 kg - m³: 1,5 - COLLI: 8

MEASURES: L 219 W 64 H 266
DESCRIPTION: wardrobe with 4 doors made of cherry wood with a fine milling on the sides and decorating frame. Inside: 4 adjustable shelves and 4 clothes rails. Accessories on request: chest of 3 drawers, tie rack, trouser rack, electronic safe, lifting hanging, rail mirror. Finishing: F34. Design by centro Ricerche MAMM
WEIGHT: 255 kg - m³: 1,5 - PIECES: 8

ART. 0377
GUARDARоба DIRETTORIO

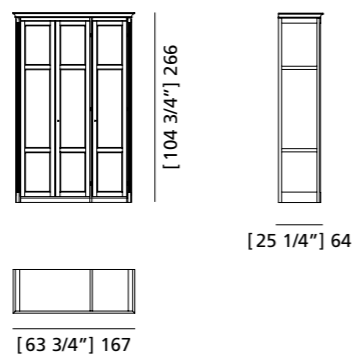

MISURE: L 167 P 64 H 266
DESCRIZIONE: armadio guardaroba a 3 ante in legno di ciliegio con pregiata fresatura sui fianchi e cornice di chiusura. Interno: 4 ripiani regolabili e 4 aste appendiabiti. Accessori su richiesta: cassetiera a 3 cassetti, portacravatte, portapantaloni, cassaforte, appendiabiti inclinabile, specchio. Finitura: F34 Design Centro Ricerche MAMM
PESO: 228 kg - m³: 1,2 - COLLI: 7

MEASURES: L 167 W 64 H 266
DESCRIPTION: wardrobe with 3 doors made of cherry wood with a fine milling on the sides and decorating frame. Inside: 4 adjustable shelves and 4 clothes rails. Accessories on request: chest of 3 drawers, tie rack, trouser rack, electronic safe, lifting hanging, rail mirror. Finishing: F34 Design by centro Ricerche MAMM
WEIGHT: 228 kg - m³: 1,2 - PIECES: 7

ART. 0378
GUARDARоба DIRETTORIO

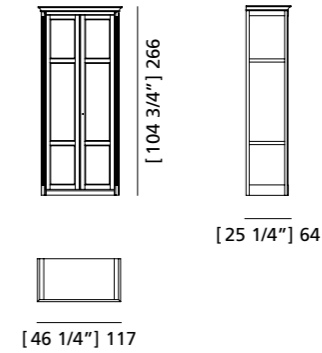

MISURE: L 117 P 64 H 266
DESCRIZIONE: armadio guardaroba a 2 ante in legno di ciliegio con pregiata fresatura sui fianchi e cornice di chiusura. Interno: 2 ripiani regolabili e 2 aste appendiabiti. Accessori su richiesta: cassetiera a 3 cassetti, portacravatte, portapantaloni, cassaforte, appendiabiti inclinabile, specchio. Finitura: F34 Design Centro Ricerche MAMM
PESO: 170 kg - m³: 1 - COLLI: 6

MEASURES: L 117 W 64 H 266
DESCRIPTION: wardrobe with 2 doors made of cherry wood with a fine milling on the sides and decorating frame. Inside: 2 adjustable shelves and 2 clothes rails. Accessories on request: chest of 3 drawers, tie rack, trouser rack, electronic safe, lifting hanging, rail mirror. Finishing: F34 Design by centro Ricerche MAMM
WEIGHT: 170 kg - m³: 1 - PIECES: 6

ART. 0367
ARMADIO RULMAN

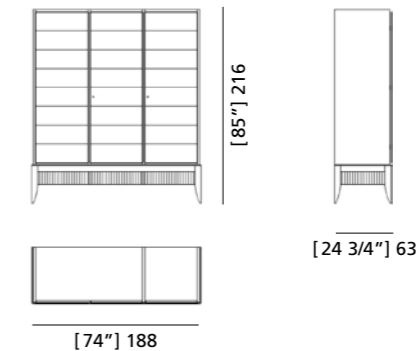

MISURE: L 188 P 63 H 216
DESCRIZIONE: armadietto in legno di ciliegio a 3 ante con pregiata impiacchiatura a venature disallineate. Interno: 2 ripiani e 2 appendiabiti, 3 cassetti a scomparsa nel basamento con controfresatura a lesene. Finitura: F60 Design Centro Ricerche MAMM
PESO: 224 kg - m³: 1,5 - COLLI: 6

MEASURES: L 188 W 63 H 216
DESCRIPTION: wardrobe made of cherry wood with 3 doors and 3 drawers. Doors veneered with a fine grain misalignment while drawers are decorated with a prestigious milling. Inside: 2 shelves and 2 clothes rails. Finishing: F60 Design by centro Ricerche MAMM
WEIGHT: 224 kg - m³: 1,5 - PIECES: 6

ART. 0302
ARMADIO LUIGI FILIPPO

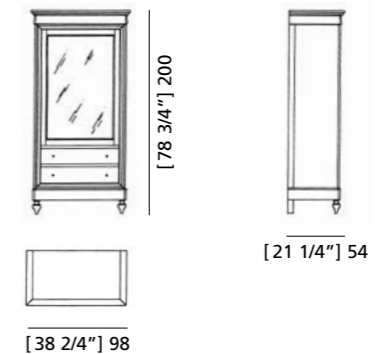

MISURE: L 98 P 54 H 200
DESCRIZIONE: armadietto ad 1 porta a specchio con appendiabiti interno. 2 cassetti a vista ed 1 cassetto a scomparsa. Su richiesta porta a vetro o in legno. Finitura: F60 Design Centro Ricerche MAMM
PESO: 82 kg - m³: 1,2 - COLLI: 1

MEASURES: L 98 W 54 H 200
DESCRIPTION: one-door cabinet with mirror, 2 drawers and 1 hidden small drawer. Inside clothing rail. Upon request wooden or glass door. Finishing: F60 Design by centro Ricerche MAMM
WEIGHT: 82 kg - m³: 1,2 - PIECES: 1

ART. A010125S
PORTA PANTALONI

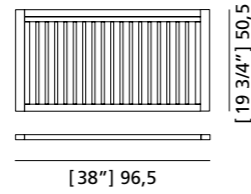

MISURE: L 96,5 P 50,5 H 2,5
DESCRIZIONE: porta pantaloni
PESO: 5 kg - m³: 0,03
COLLI: 1

MEASURES: L 96,5 W 50,5 H 2,5
DESCRIPTION: trouser rack.
WEIGHT: 5 kg - m³: 0,03
PIECES: 1

ART. A010124S
PORTA CRAVATTE

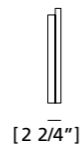
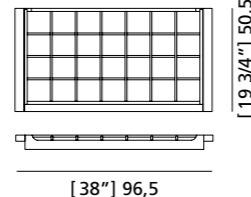

MISURE: L 96,5 P 50,5 H 7
DESCRIZIONE: porta cravatta
PESO: 4 kg - m³: 0,01
COLLI: 1

MEASURES: L 96,5 W 50,5 H 7
DESCRIPTION: tie rack.
WEIGHT: 4 kg - m³: 0,01
PIECES: 1

ART. S100001S
CASSETTIERA INTERNA

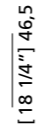
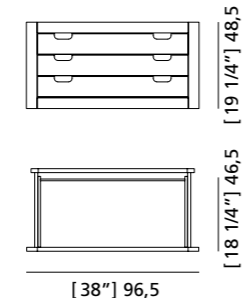

MISURE: L 96,5 P 46,5 H 48,5
DESCRIZIONE: cassettera interna
PESO: 20 kg - m³: 0,30
COLLI: 1

MEASURES: L 96,5 W 46,5 H 48,5
DESCRIPTION: internal chest of drawers.
WEIGHT: 20 kg - m³: 0,30
PIECES: 1

ART. S090005S
RIPIANO INTERNO

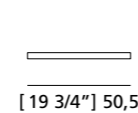
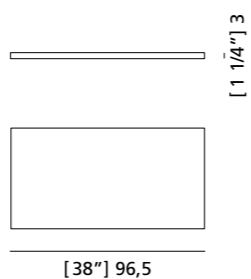

MISURE: L 96,5 P 50,5 H 3
DESCRIZIONE: ripiano interno
PESO: 2 kg - m³: 0,01
COLLI: 1

MEASURES: L 96,5 W 50,5 H 3
DESCRIPTION: internal shelf.
WEIGHT: 2 kg - m³: 0,01
PIECES: 2

ACCESSORI ACCESSORIES

CASSA IN LEGNO PER IMBALLAGGIO (PREZZO NETTO) / WOODEN CRATE (NET PRICE) **0,5 CBM**

CASSA IN LEGNO PER IMBALLAGGIO (PREZZO NETTO) / WOODEN CRATE (NET PRICE) **1 CBM**

CASSA IN LEGNO PER IMBALLAGGIO (PREZZO NETTO) / WOODEN CRATE (NET PRICE) **2 CBM**

CASSA IN LEGNO PER IMBALLAGGIO (PREZZO NETTO) / WOODEN CRATE (NET PRICE) **3 CBM**

A010180S TUBO OTTONE PER LIBRERIE / BRASS PIPE FOR BOOKCASE - MT.L

3345 SCALA PER LIBRERIE / LADDER FOR BOOKCASE

A160002S COPRIMATERASSO SINGOLO / SINGLE MATTRESS COVER

A160002S COPRIMATERASSO MATRIMONIALE / DOUBLE MATTRESS COVER

A160021S CUSCINO RETTANGOLARE / CUSHION 100 X 50

S100001S CASSETTIERA PER ARMADI / CHEST FOR WARDROBES

S090005S RIPIANO GUARDAROBA 2P / WARDROBE SHELF

S090006S RIPIANO GUARDAROBA 1P / WARDROBE SHELF

A010074S APPENDIABITI INCLINABILE PER ARMADI / TILTABLE COAT HANGER

A120018S SPECCHIO INTERNO PER ARMADI / MIRROR FOR WARDROBE

A010183S LED LIBRERIA BIEDERMEIER FS379725

A010183S LED LIBRERIA BIEDERMEIER FS3710182

A010207S TRASFORMATORE PER LED / LED LIGHT DRIVER

A010208S LED FOR ART. 3708

A010209S LED FOR ART. 3709

A010210S LED FOR ART. 3712

A010211S LED FOR ART. 3713

A010212S LED FOR ART. 3714

A010213S LED FOR ART. 3721

A010214S LED FOR ART. 3722

A010215S LED FOR ART. 3727

A010216S LED FOR ART. 3728

A010206S PROFILO LED AL MT.L. / LED BAR LINEAR MT. (DRIVER EXCLUDED)

CAT. B. TESSUTO AL MT. / FABRIC LINEAR MT.

CAT. C. TESSUTO COTONE AL MT. / FABRIC LINEAR MT.

CAT. C. VELLUTO AL MT. / VELVET LINEAR MT.

CAT. D. PELLE AL MQ. / LEATHER SQM.

CAT. D. ALCANTARA AL MT. / ALCANTARA LINEAR MT.

A500052S KIT RITOCOCCO / RETOUCH KIT



FINITURE
TESSUTI

FINISH
FABRICS

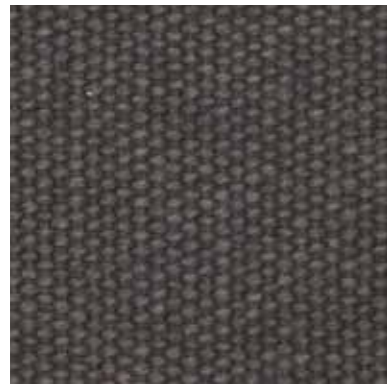

ART. A112031S

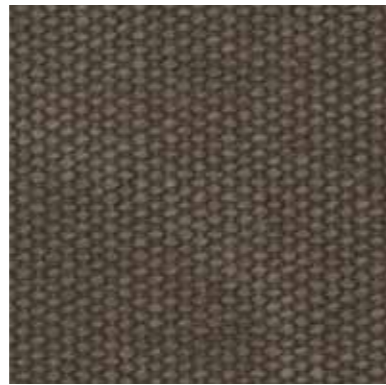

ART. A112032S



ART. A112059S



ART. A112045S

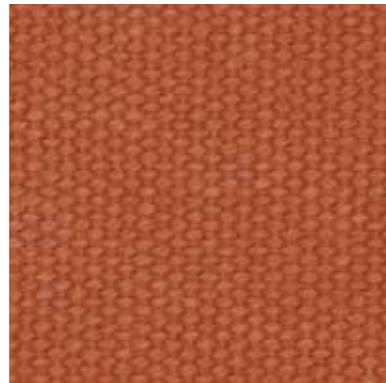

ART. A112046S



ART. A112064S

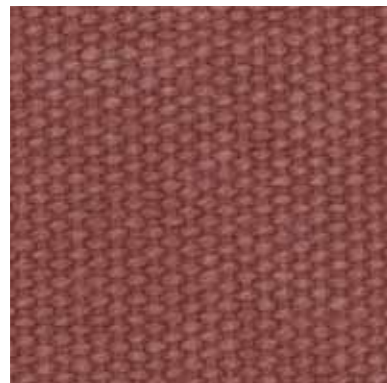

ART. A112047S



ART. A112048S



ART. A112062S



ART. A112035S

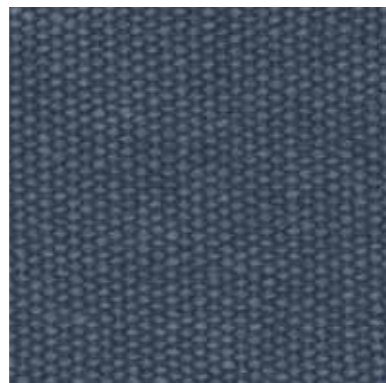

ART. A112036S

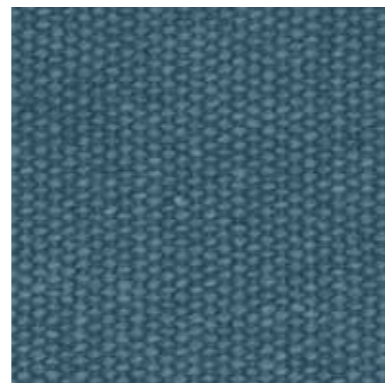

ART. A112037S

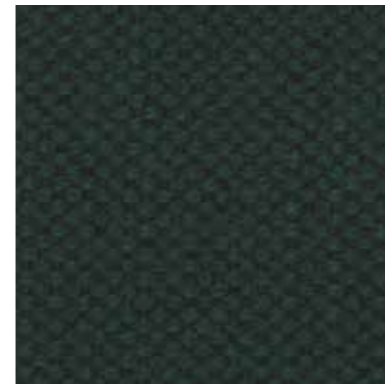

ART. A112065S

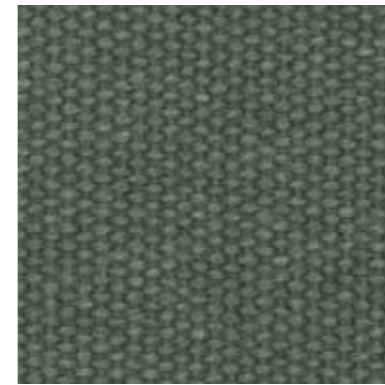

ART. A112043S

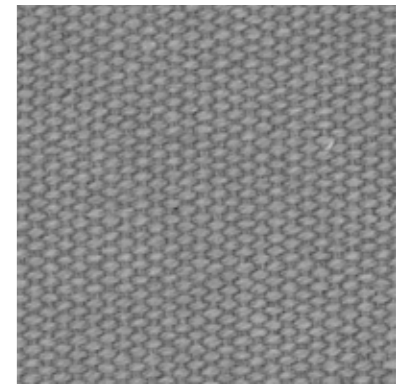

ART. A112051S

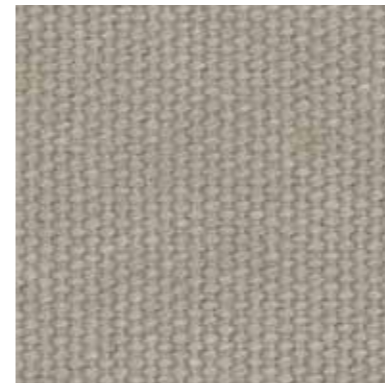

ART. A112052S

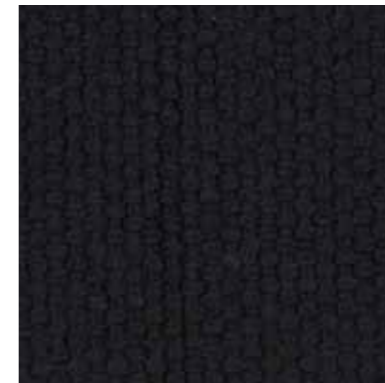

ART. A112066S



ART. A112030S

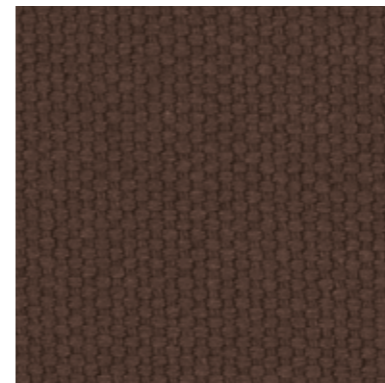

ART. A112060S



ART. A112034S



ART. A112033S

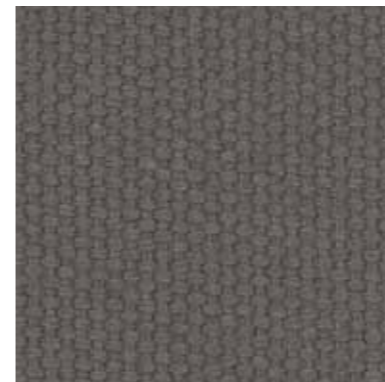

ART. A112049S

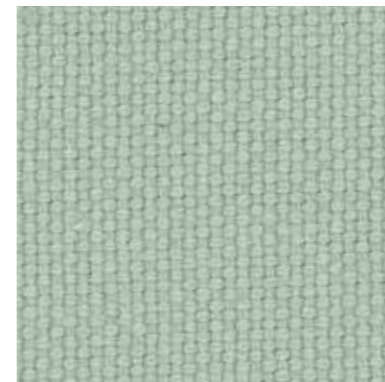

ART. A112061S



ART. A112063S



ART. A112058S



ART. A112040S



ART. A112042S



ART. A112056S



ART. A112057S



ART. A112055S



ART. A112050S



ART. A112054S



ART. A112044S



ART. A112041S



ART. A112039S



ART. A112038S



ART. A113236S BLANC



ART. A113235S NATUREL



ART. A113238S ROSE



ART. A113237S JAUNE TENDRE

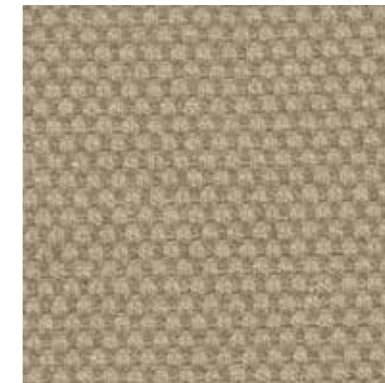

ART. A113234S GRIS CLAIRE



ART. A113240S MASTIC

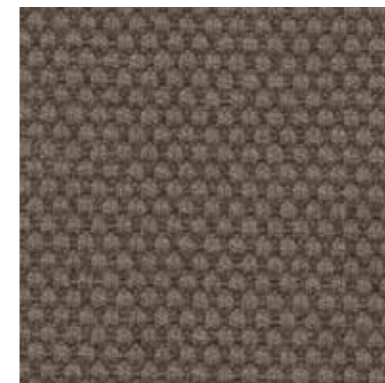

ART. A113242S BOUE



ART. A113239S ARGILE



ART. A113244S MARRON GLACE



ART. A113241S SOURIS



ART. A113245S BLEU DE PRUSSE



ART. A113243S ACIER



ART. A113224S BLANC



ART. A113225S JAUNE TENDRE



ART. A113223S NATUREL



ART. A113226S ROSE



ART. A113222S GRIS CLAIRE



ART. A113229S SOURIS



ART. A113228S MASTIC



ART. A113227S ARGILE



ART. A113230S BOUE



ART. A113231S ACIER



ART. A113233S BLEU DE PRUSSE



ART. A113232S MARRON GLACE



ART. A113211S MADREPERLA



ART. A113219S ROSE

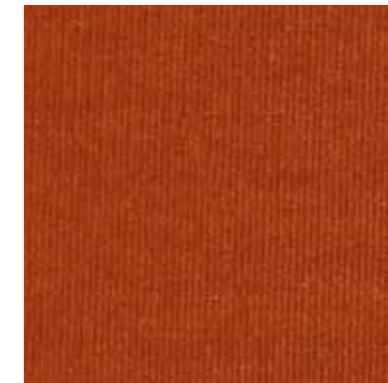

ART. A113217S SUNSET



ART. A113220S VIOLET



ART. A113218S DIASPRO



ART. A113221S SMOKE



ART. A113210S ARGENT



ART. A113212S ARTIC



ART. A113215S DENIM



ART. A113214S OLTREMARE



ART. A113213S FIORDO



ART. A113216S FOREST



ART. A115001S



ART. A115002S



ART. A115004S



ART. A115003S

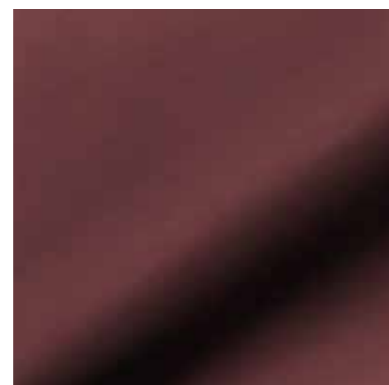

ART. A115011S

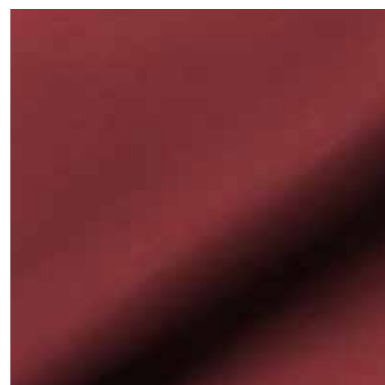

ART. A115012S



ART. A115009S



ART. A115007S



ART. A115008S



ART. A115005S

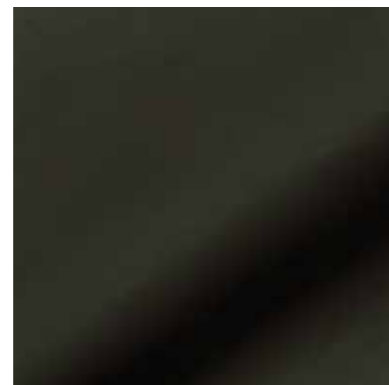

ART. A115006S

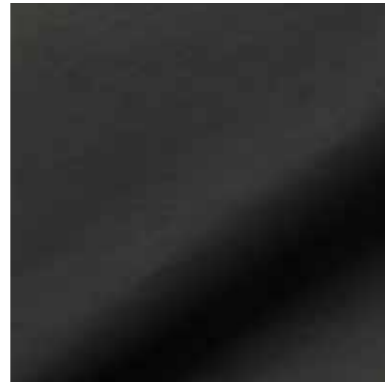

ART. A115010S

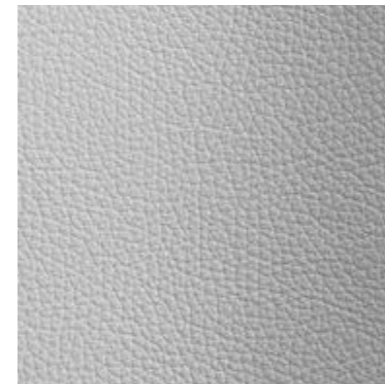

ART. A114039S



ART. A114031S



ART. A114032S

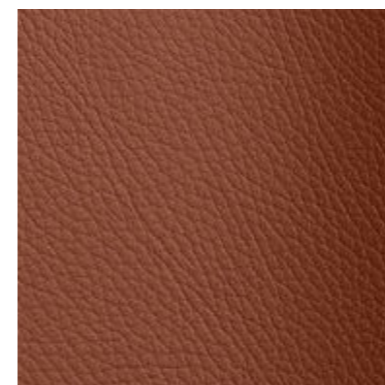

ART. A114053S

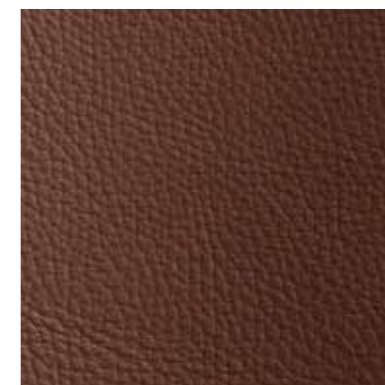

ART. A114036S



ART. A114035S



ART. A114040S



ART. A114037S



ART. A114030S

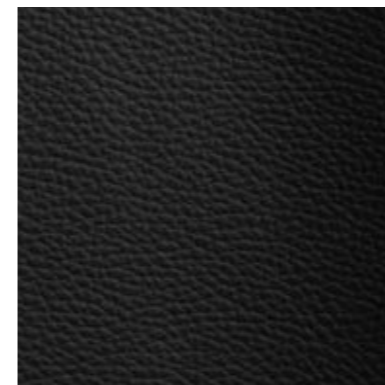

ART. A114038S



ART. A114034S



ART. A1140052S



ART. A114015S



ART. A114017S



ART. A114016S



ART. A114055S



ART. A114054S



ART. A114018S



ART. A114019S



ART. A114044S



ART. A114056S



ART. A114026S



ART. A114059S



ART. A114025S



ART. A114014S



ART. A114027S



ART. A114051S



ART. A114024S



ART. A114023S

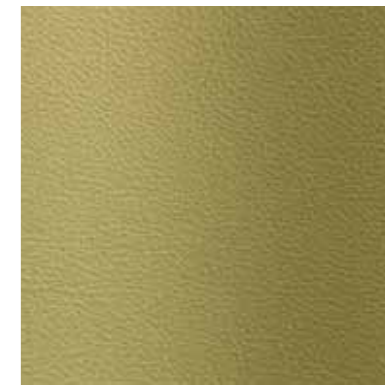

ART. A114022S



ART. A114021S



ART. A114020S



ART. A114057S



ART. A114047S



ART. A114028S



ART. A114029S



ART. A114058S



ART. A114010S



ART. A114011S

I mobili della produzione Morelato sono realizzati usando legno di:
Acero, Ciliegio, Ebano, Frassino, Noce Canaletto, Padouk, Wengè, Zebrano, Rovere.
Le essenze sono poi trattate con diverse possibilità di finitura superficiale.

*The Morelato furniture is made using the following wood:
Maple, Cherry, Ebony, Walnut, Padouk, Wengè, Zebrano and Oak.
The surfaces of the wood are then treated with different kinds of finishing.*



ACERO

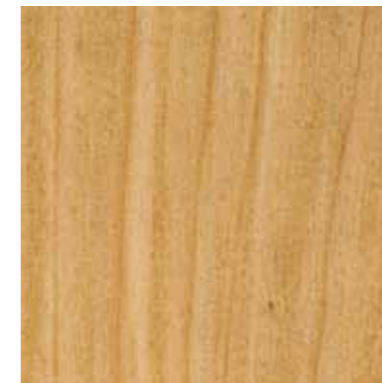

CILIEGIO



EBANO



FRASSINO



NOCE CANALETTO



PADOUK



WENGÉ



ROVERE



ZEBRANO

FINITURE PER MOBILI IN ESSENZA DI CILIEGIO
FINISHING FOR CHERRY WOOD FURNITURE



F32/C TRASPARENTE



F30 FINITURA NATURALE



F34 FINITURA ACERO



F60 FINITURA CILIEGIO



F80 FINITURA MOGANO

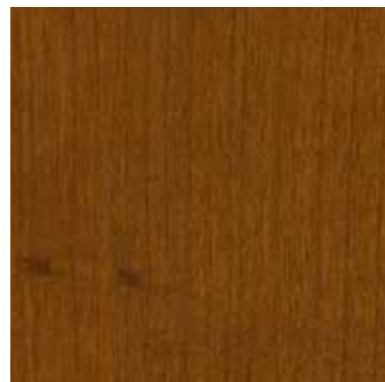

F100 FINITURA NOCE

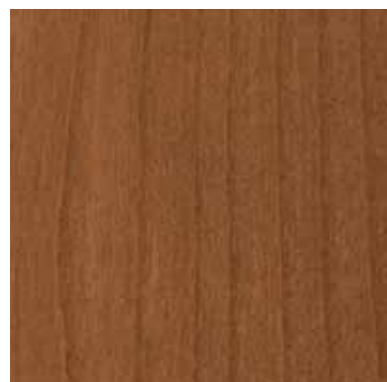

F160 FINITURA NOCE CANALETTO

FINITURE PER MOBILI IN ESSENZA DI FRASSINO
FINISHING FOR ASH WOOD FURNITURE



F32/F TRASPARENTE



F140 FINITURA COLORE NERO



F150 FINITURA COLORE WENGÉ



F160 FINITURA COLORE NOCE



F170 FINITURA COLORE ROVERE

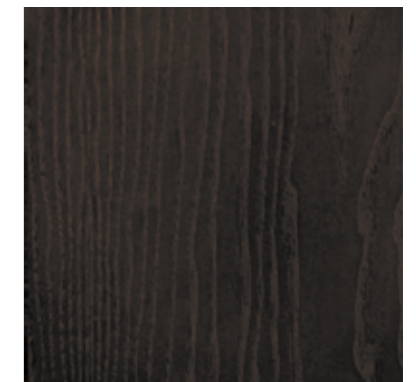

F180 FINITURA COLORE MOKA

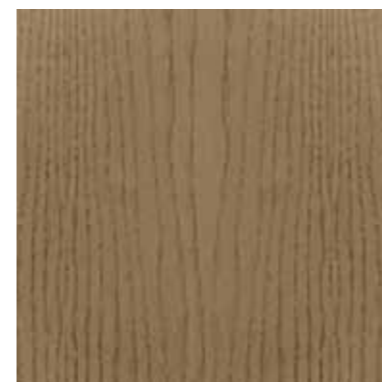

F190 FINITURA COLORE CASTAGNO

FINITURE PER MOBILI IN ESSENZA
DI ACERO
FINISHING FOR MAPLE WOOD
FURNITURE

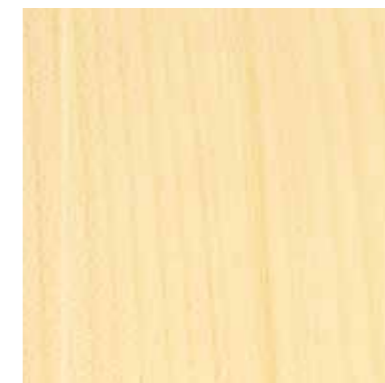

F32/A
TRASPARENTE

FINITURE PER MOBILI IN ESSENZA
DI NOCE CANALETTO
FINISHING FOR WALNUT WOOD
FURNITURE



F32/N
TRASPARENTE



F.L.1 FINITURA LACCATO
BORDATO VERDE



F.L.2 FINITURA LACCATO
BORDATO AZZURRO



F.L.5 FINITURA LACCATO
BORDATO MARRONE

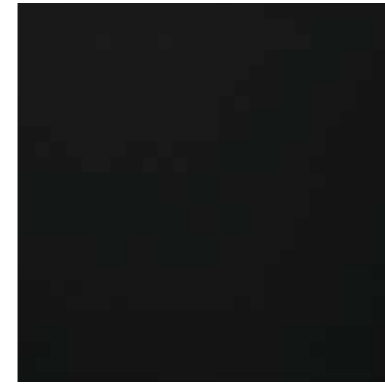

F.L.50 FINITURA COLORATO
NERO OPACO



F.L.60 FINITURA COLORATO
BIANCO OPACO



F.L.80 FINITURA COLORATO
VERDE



F.L.11 FINITURA COLORATO
BEIGE



F.L.90 FINITURA COLORATO
ARANCIO



F.L.100 FINITURA COLORATO
AZZURRO



F.L. 120 FINITURA COLORATO
GRIGIO



F.L. 130 FINITURA COLORATO
GIALLO



F.L.140 FINITURA COLORATO
ROSSO



F.L.150 FINITURA COLORATO
BLUE



F.L. 20 FOGLIA ORO



F.L. 21 FOGLIA ARGENTO



F.L. 160 FINITURA COLORATO
TORTORA



F.L.170 FINITURA COLORATO
SABBIA

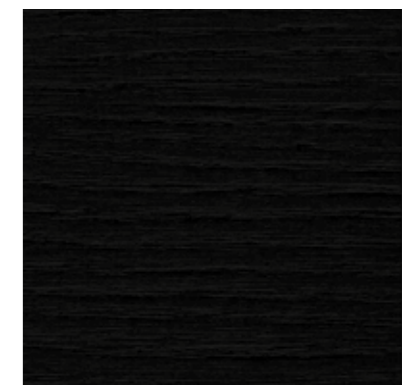

F.L.180 FINITURA COLORATO
ANTRACITE

0302	ARMADIO LUIGI FILIPPO	PAG.	199	1365	COMODINO VITTORIO	PAG.	175	2847	LETTO DIRETTORIO	PAG.	167	3440	ANTA CODE ZERO	PAG.	57
0327	GUARDAROBA SCACCHI 6P	PAG.	196	1365/N	COMODINO VITTORIO NOCE	PAG.	175	2850	LETTO RULMAN	PAG.	167	3441	ANTA CODE ZERO	PAG.	60
0331	GUARDAROBA SCACCHI 5P	PAG.	196	1366/F	COMODINO ANERIO	PAG.	174	2884	LETTO GIO'	PAG.	165	3442/F	MONTANTE SHARK	PAG.	21
0332	GUARDAROBA SCACCHI 4P	PAG.	196	1367/F	COMODINO MALIBU'	PAG.	177	2885	LETTO UMBERTO	PAG.	167	3443/F	RIPIANO SHARK	PAG.	21
0348	GUARDAROBA SCACCHI 2P	PAG.	197	1368	COMODINO FEDELE	PAG.	176	2887	LETTO GIO'	PAG.	165	3444/F	RIPIANO SHARK	PAG.	21
0349	GUARDAROBA SCACCHI 3P	PAG.	196	1703	CREDENZA FANTESCA	PAG.	99	2889/F	LETTO MAGIC DREAM	PAG.	165	3445	FIANCO A SCALETTA ZERO	PAG.	63
0362	GUARDAROBA 900 6P	PAG.	194	1705/F	CREDENZA MALIBU'	PAG.	100	2890	LETTO FELICE	PAG.	165	3453	FIANCO A SCALETTA ZERO	PAG.	63
0363	GUARDAROBA 900 5P	PAG.	194	1707	CREDENZA SIPARIO	PAG.	100	2891	LETTO VALENTINO	PAG.	166	3454	ANTA MATTONCINI ZERO	PAG.	55
0364	GUARDAROBA 900 4P	PAG.	194	1708	CREDENZA SHERWOOD	PAG.	100	3009	MOBILE DIRETTORIO	PAG.	80	3455	ANTA MATTONCINI ZERO	PAG.	59
0365	GUARDAROBA 900 3P	PAG.	194	1709	CREDENZA VERONESE	PAG.	99	3010	MOBILE DIRETTORIO	PAG.	80	3456	ANTA OBLO' ZERO	PAG.	55
0366	GUARDAROBA 900 2P	PAG.	195	1715	MOBILE BAR VERONESE	PAG.	96	3011	MOBILE DIRETTORIO	PAG.	81	3457	ANTA VETRO ZERO	PAG.	55
0367	ARMADIO RULMAN	PAG.	199	1718	CREDENZA CAVALLETTO	PAG.	103	3012	MOBILE DIRETTORIO	PAG.	81	3458	ANTA VETRO ZERO	PAG.	59
0371	GUARDAROBA 900 SCORREVOLE	PAG.	195	1720/Z	MOBILE GIANO	PAG.	103	3013	MOBILE DIRETTORIO	PAG.	82	3459	ANTA LISTELLI ZERO	PAG.	55
0372	GUARDAROBA SCACCHI SCORREVOLE	PAG.	197	1721	CREDENZA BIG JOHN	PAG.	99	3015	MOBILE DIRETTORIO	PAG.	82	3460	ANTA LISTELLI ZERO	PAG.	59
0374	GUARDAROBA DIRETTORIO 6P	PAG.	198	1722	CREDENZA ZERO	PAG.	101	3017	MOBILE DIRETTORIO	PAG.	81	3461	ANTA FRESATA ZERO	PAG.	56
0375	GUARDAROBA DIRETTORIO 5P	PAG.	198	1733/F	CREDENZA SWING	PAG.	38/97	3018	MOBILE DIRETTORIO	PAG.	81	3463	ANTA FINESTRA ZERO	PAG.	56
0376	GUARDAROBA DIRETTORIO 4P	PAG.	198	1734/F	CREDENZA SWING	PAG.	38/97	3019	MOBILE DIRETTORIO	PAG.	82	3464	ANTA ONDA ZERO	PAG.	56
0377	GUARDAROBA DIRETTORIO 3P	PAG.	198	1735/F	CREDENZA SWING	PAG.	38/97	3029	MOBILE DIRETTORIO	PAG.	82	3466	ANTA ARCO ZERO	PAG.	56
0378	GUARDAROBA DIRETTORIO 2P	PAG.	199	1736/F	CREDENZA SWING	PAG.	38	3103	MODULO PRESIDENT	PAG.	86	3468	BASE CAVALLETTO ZERO	PAG.	61
0395	MODULO GUARDAROBA PRESIDENT	PAG.	190	1737	CREDENZA PORTA TV ZERO	PAG.	103	3104	MODULO PRESIDENT	PAG.	86	3469	BASE ARCO ZERO	PAG.	62
0396	MODULO GUARDAROBA PRESIDENT	PAG.	190	1738/F	CREDENZA JOYCE	PAG.	96	3105	MODULO PRESIDENT	PAG.	86	3470	MODULO ZERO STRUTTURA	PAG.	54
0397	MODULO GUARDAROBA PRESIDENT	PAG.	190	1739/F	CREDENZA JOYCE	PAG.	96	3106	CORNICE PRESIDENT	PAG.	87	3471	MODULO ZERO STRUTTURA	PAG.	54
0398	MODULO GUARDAROBA PRESIDENT	PAG.	190	1741/F	CREDENZA BELLAGIO	PAG.	97	3266	MOBILE BIBLIOTECA	PAG.	24	3472	MODULO ZERO STRUTTURA	PAG.	54
0399	MODULO CORNICE GUARDAROBA PRESIDENT	PAG.	191	1742/F	CREDENZA SWING	PAG.	39/98	3267	MOBILE BIBLIOTECA	PAG.	24	3473	ELEMENTO SCRITTOIO ZERO	PAG.	60
0419/N	SERVOMUTO IDEALISTA	PAG.	149	1743/F	CREDENZA SWING	PAG.	39/98	3268	MOBILE BIBLIOTECA	PAG.	24	3474	BASE CAVALLETTO ZERO	PAG.	61
0801	CASSETTIERA NEW YORK	PAG.	178	1744/F	CREDENZA SWING	PAG.	39/98	3274	MOBILE BIBLIOTECA	PAG.	24	3475	MODULO ZERO STRUTTURA	PAG.	53
0805/F	CASSETTIERA ELLA	PAG.	173	1763	CREDENZA LOCANDIERA	PAG.	99	3345	SCALA PER LIBRERIE	PAG.	5/76/83/201	3476	MODULO ZERO STRUTTURA	PAG.	59
0831	CASSETTIERA BIEDERMEIER	PAG.	179	1781	CREDENZA ZERO	PAG.	101	3353	BASE 900 PORTA TV	PAG.	104	3477	MODULO ZERO STRUTTURA	PAG.	58
0834/F	CASSETTIERA BELLAGIO	PAG.	173	1785	CREDENZA BIEDERMEIER	PAG.	104	3360/F	MOBILE NOVECENTO	PAG.	67	3478	MODULO ZERO STRUTTURA	PAG.	53
1201/F	COMO' BELLAGIO	PAG.	173	1788	CREDENZA BIEDERMEIER	PAG.	104	3361/F	MOBILE NOVECENTO	PAG.	67	3479	MODULO ZERO STRUTTURA	PAG.	58
1202/F	COMO' BELLAGIO	PAG.	172	1789	CREDENZA ZERO OBLO'	PAG.	101	3362/F	MOBILE NOVECENTO	PAG.	67	3481	MODULO ZERO STRUTTURA	PAG.	58
1203/F	COMO' JOYCE	PAG.	172	1796	CREDENZA ZERO	PAG.	101	3363/F	MOBILE NOVECENTO	PAG.	67	3482	MODULO ZERO STRUTTURA	PAG.	53
1204	COMO' SCACCHI	PAG.	176	1798	CREDENZA ZERO	PAG.	102	3364/F	MOBILE NOVECENTO	PAG.	68	3486	MODULO ZERO STRUTTURA 1 CASSETTO	PAG.	60
1205/F	COMO' DUKE	PAG.	174	1799	CREDENZA ZERO	PAG.	102	3365/F	MOBILE NOVECENTO	PAG.	68	3491	MODULO ZERO STRUTTURA	PAG.	57
1243	COMO' DIRETTORIO	PAG.	180	2227	DIVANO DIRETTORIO	PAG.	160	3366/F	MOBILE NOVECENTO	PAG.	68	3492	MODULO ZERO STRUTTURA	PAG.	58
1253	COMO' NEW YORK	PAG.	178	2228	DIVANO 900 CLUB	PAG.	158	3367/F	CORNICE NOVECENTO	PAG.	68	3493	MODULO ZERO STRUTTURA	PAG.	53
1257	COMO' RULMAN	PAG.	178	2231	DIVANO BIEDERMEIER	PAG.	159	3401	LIBRERIA CARTESIA	PAG.	93	3494	MODULO ZERO STRUTTURA	PAG.	54
1258	COMO' BIEDERMEIER	PAG.	179	2235	DIVANO MILANO	PAG.	157	3403	CONTENIORE SCALA	PAG.	48	3495	MODULO ZERO STRUTTURA 3 CASSETTO	PAG.	57
1268	COMO' VITTORIO	PAG.	175	2238	DIVANO TORINO	PAG.	158	3404	CONTENIORE SCALA	PAG.	48	3496	MODULO ZERO PEDANA	PAG.	62
1268/N	COMO' VITTORIO NOCE	PAG.	175	2241	DIVANO LETTO GIO'	PAG.	157	3405	ANTA A VETRO SCALA	PAG.	48	3497	ANTA COLORATA ZERO	PAG.	57
1269/F	COMO' ANERIO	PAG.	174	2242	DORMEUSE PAOLINA	PAG.	159	3406	ANTA A LISTELLI SCALA	PAG.	48	3498	ANTA COLORATA ZERO	PAG.	60
1271	COMO' NEW YORK	PAG.	177	2245/F	DIVANO BELLAGIO	PAG.	156	3407	ANTA A MATTONCINI SCALA	PAG.	49	3514	RIPIANO MASCHERA	PAG.	16
1272/F	COMO' MALIBU'	PAG.	177	2246/F	DIVANO BELLAGIO	PAG.	156	3408	SCRITTOIO LIBRERIA SCALA	PAG.	47	3517	CORNICE MASCHERA	PAG.	16
1273	COMO' FEDELE	PAG.	176	2247/F	DIVANO BELLAGIO	PAG.	156	3410	FIANCO O TRAMEZZA SCALA	PAG.	47	3535	MASCHERA A GIORNO	PAG.	6/11
1301/F	COMODINO BELLAGIO	PAG.	173	2249/F	DIVANO BELLAGIO	PAG.	156	3411	RIPIANO SCALA	PAG.	47	3537	COMPOSIZIONE LIBRERIA MASCHERA	PAG.	4/11
1302/F	COMODINO BELLAGIO C/CASSETTO	PAG.	172	2801	LETTO ORLANDO	PAG.	166	3413	COMPOSIZIONE LIBRERIA SCALA	PAG.	46	3538	MASCHERA A GIORNO	PAG.	6/11
1303/F	COMODINO JOYCE	PAG.	172	2802/F	LETTO SWING	PAG.	164	3416	RIPIANO SCALA	PAG.	47	3541	COMPOSIZIONE LIBRERIA MASCHERA	PAG.	10
1305/F	COMODINO LOUIS	PAG.	174	2806	LETTO FORTUNATO	PAG.	166	3418	ANTA COLORATA SCALA	PAG.	49	3541/F	COMPOSIZIONE LIBRERIA MASCHERA	PAG.	10
1348	COMODINO DIRETTORIO	PAG.	180	2807/F	LETTO BELLAGIO	PAG.	164	3419	ANTA CODE SCALA	PAG.	49	3552	COPPIA ANTE LEGNO MASCHERA	PAG.	13
1356	COMODINO RULMAN	PAG.	179	2808/F	LETTO BELLAGIO	PAG.	164	3429	MODULO ZERO BASE	PAG.	62	3553	COPPIA VETRO LEGNO MASCHERA	PAG.	14
1361	COMODINO NEW YORK	PAG.	178	2809/F	LETTO JOYCE	PAG.	164	3432	PANNELLO BOISERIE ZERO	PAG.	61	3554	COPPIA ANTE LEGNO MASCHERA	PAG.	13
1362	COMODINO BIEDERMEIER	PAG.	179	2821	LETTO LUIGI FILIPPO	PAG.	167	3437	MODULO ZERO MENSOLA	PAG.	61	3555	COPPIA VETRO LEGNO MASCHERA	PAG.	14

3556	COPPIA ANTE LEGNO MASCHERA	PAG.	13	3674/F	MODULO SWING	PAG.	184	3886	POLTRONA MILANO	PAG.	157	5332/F	SGABELLO JENNY	PAG.	136
3557	COPPIA VETRO LEGNO MASCHERA	PAG.	14	3675/F	MODULO SWING	PAG.	184	3888	POLTRONA GIREVOLE BOSS	PAG.	130	5333/F	SGABELLO BELLAGIO	PAG.	136
3558	COPPIA ANTE LEGNO MASCHERA	PAG.	13	3676/F	MODULO SWING	PAG.	184	3890/F	POLTRONCINA COOPER	PAG.	125	5334/F	PANCA BELLAGIO	PAG.	138
3559	COPPIA VETRO LEGNO MASCHERA	PAG.	14	3677/F	MODULO SWING	PAG.	184	3891	POLTRONCINA BURTON	PAG.	125	5335	POUF CAPITONNE'	PAG.	138
3560	CORNICE SAGOMATA MASCHERA	PAG.	16	3678/F	MODULO SWING	PAG.	185	3893/F	POLTRONCINA RONSON	PAG.	124	5336	SGABELLO BAR MUSA	PAG.	136
3565	CORNICE MASCHERA	PAG.	11	3679/F	MODULO SWING	PAG.	185	3894	POLTRONA TORINO	PAG.	158	5337/F	SGABELLO COOPER	PAG.	134
3566	CORNICE MASCHERA	PAG.	12	3680/F	MODULO SWING	PAG.	185	3897	POLTRONCINA PRESIDENT GIREVOLE	PAG.	131	5338/F	SGABELLO BURTON	PAG.	134
3567	CORNICE MASCHERA	PAG.	12	3681/F	MODULO SWING	PAG.	185	3897	POLTRONCINA PRESIDENT GIREVOLE CAPITONNE'	PAG.	131	5405	SPECCHIO DIRETTORIO	PAG.	150
3568	CORNICE MASCHERA	PAG.	12	3682/F	MODULO SWING	PAG.	186	3898	POLTRONCINA DONDOLO BURTON	PAG.	155	5406	SPECCHIO DIRETTORIO	PAG.	150
3569	CORNICE MASCHERA	PAG.	12	3683/F	RIPIANO MODULO SWING	PAG.	186	3899/A	POLTRONA CHAISE Morelato	PAG.	154	5415	SPECCHIO 900	PAG.	150
3570	CORNICE SAGOMATA MASCHERA	PAG.	15	3686/F	ANTA PAGLIA MODULO SWING	PAG.	43	5002/F	SCRIVANIA BELLAGIO	PAG.	117	5604	TAVOLINO PATCHWORK	PAG.	146
3571	CORNICE SAGOMATA MASCHERA	PAG.	15	3687/F	ANTA VETRO MODULO SWING	PAG.	43	5003/F	SCRIVANIA SWING	PAG.	117	5606	TAVOLINO BOOK	PAG.	145
3572	CORNICE SAGOMATA MASCHERA	PAG.	15	3689	CUBO IN FERRO SWING	PAG.	31	5004/F	SCRIVANIA ISABEL	PAG.	116	5607	TAVOLINO CARAMBOLA	PAG.	145
3573	CORNICE SAGOMATA MASCHERA	PAG.	15	3708	MODULO LIBRERIA BIEDERMEIER	PAG.	72	5051	SCRIVANIA FLAMINIA	PAG.	116	5610	TAVOLINO CARAMBOLA VETRO	PAG.	144
3581/F	ANTA SCORREVOLE MASCHERA	PAG.	5	3709	MODULO LIBRERIA BIEDERMEIER	PAG.	72	5069	SCRIVANIA DIRETTORIO	PAG.	118	5611/B	TAVOLINO CINO ALTO	PAG.	143
3582/F	ANTA SCORREVOLE MASCHERA	PAG.	5	3710	MODULO LIBRERIA BIEDERMEIER	PAG.	74	5070	SCRIVANIA DIRETTORIO	PAG.	118	5611/G	TAVOLINO CINO ALTO	PAG.	143
3583/F	FASCIA MASCHERA SCORREVOLE	PAG.	5	3711	MODULO CORNICE LIBRERIA BIEDERMEIER	PAG.	75	5075	SCRIVANIA DIRETTORIO	PAG.	118	5611/R	TAVOLINO CINO ALTO	PAG.	143
3620/F	LIBRERIA KANT	PAG.	91	3712	MODULO LIBRERIA BIEDERMEIER	PAG.	73	5078	SCRIVANIA ROMA	PAG.	116	5611/V	TAVOLINO CINO ALTO	PAG.	143
3620/N	LIBRERIA KANT NOCE	PAG.	91	3713	MODULO LIBRERIA BIEDERMEIER	PAG.	74	5080	SCRITTOIO EUGENIO	PAG.	117	5612/B	TAVOLINO CINO BASSO	PAG.	143
3630/F	MODULO SWING	PAG.	28	3714	MODULO LIBRERIA BIEDERMEIER	PAG.	74	5081	SCRIVANIA PRESIDENT	PAG.	116	5612/G	TAVOLINO CINO BASSO	PAG.	143
3631/F	MODULO SWING	PAG.	28	3721	MODULO LIBRERIA BIEDERMEIER	PAG.	73	5102/F	SEDIA JENNY	PAG.	123	5612/R	TAVOLINO CINO BASSO	PAG.	143
3632/F	MODULO SWING	PAG.	28	3722	MODULO LIBRERIA BIEDERMEIER	PAG.	73	5103/F	SEDIA JOYCE	PAG.	122	5612/V	TAVOLINO CINO BASSO	PAG.	143
3633/F	MODULO SWING	PAG.	29	3723	MODULO LIBRERIA BIEDERMEIER	PAG.	73	5104/F	SEDIA BELLAGIO	PAG.	122	5615/P	TAVOLINO FRANK	PAG.	142
3634/F	MODULO SWING	PAG.	29	3727	MODULO LIBRERIA BIEDERMEIER	PAG.	75	5105/F	SEDIA SAVINA	PAG.	124	5616/A	TAVOLINO GENE	PAG.	142
3642/F	MODULO SWING CASSETTO	PAG.	31	3728	MODULO LIBRERIA BIEDERMEIER	PAG.	75	5107/N	SEDIA INGE	PAG.	123	5620/F	TAVOLINO TRIFOGLIO	PAG.	142
3643/F	MODULO SWING CASSETTO	PAG.	30	3729	MODULO LIBRERIA BIEDERMEIER	PAG.	75	5110	SEDIA DIANA	PAG.	127	5621/F	TAVOLINO LAYERS	PAG.	142
3644/F	MODULO SWING	PAG.	29	3730	MODULO LIBRERIA BIEDERMEIER	PAG.	76	5154	SEDIA FLORA	PAG.	128	5626/F	TAVOLINO BELLAGIO	PAG.	144
3645/F	MODULO SWING	PAG.	29	3731	MODULO LIBRERIA BIEDERMEIER	PAG.	74	5173	SEDIA IMPERIA	PAG.	127	5627/F	TAVOLINO BELLAGIO	PAG.	144
3646/F	MODULO SWING	PAG.	30	3801/F	POLTRONCINA GIREVOLE AGATHA	PAG.	130	5181	SEDIA CLARA	PAG.	129	5628/F	TAVOLINO BELLAGIO	PAG.	144
3647/F	MODULO SWING	PAG.	30	3802/N	POLTRONCINA MALIBU'	PAG.	155	5182	SEDIA ZERO IMPILABILE	PAG.	126	5640	TAVOLINO SCACCHI	PAG.	146
3648/F	MODULO SWING	PAG.	30	3804	POLTRONCINA PRESIDENT	PAG.	128	5186	SEDIA VESTA	PAG.	128	5664	TAVOLINO BIEDERMEIER	PAG.	147
3653/F	MODULO SWING	PAG.	40	3805/F	POLTRONCINA JENNY	PAG.	123	5187	SEDIA MUSA	PAG.	128	5688	TAVOLINO DIRETTORIO	PAG.	147
3654/F	MODULO SWING	PAG.	40	3806	POLTRONCINA ROBERTA	PAG.	126	5187	SEDIA MUSA CAPITONNE'	PAG.	129	5696	TAVOLINO BIEDERMEIER	PAG.	147
3655/F	MODULO SWING	PAG.	40	3808	POLTRONCINA PRESIDENT ACCIAIO	PAG.	131	5188	SEDIA CIAK	PAG.	125	5698	TAVOLINO SCACCHI	PAG.	146
3656/F	MODULO SWING	PAG.	40	3809/F	POLTRONCINA BELLAGIO	PAG.	122	5189	SEDIA GIREVOLE PRESIDENT	PAG.	131	5701/F	TAVOLO JOYCE	PAG.	108
3657/F	MODULO SWING	PAG.	41	3810/F	POLTRONCINA BELLAGIO CON RUOTE	PAG.	130	5191	SEDIA PRISCILLA	PAG.	127	5701/FPP	TAVOLO JOYCE PIANO PIETRA	PAG.	108
3658/F	MODULO SWING	PAG.	41	3811/F	POLTRONA AIDA	PAG.	155	5193/F	SEDIA MALIBU'	PAG.	126	5705/F	TAVOLO JOYCE	PAG.	108
3659/F	MODULO SWING CASSETTO	PAG.	42	3814/F	POLTRONA JOYCE	PAG.	154	5194	SEDIA BURTON	PAG.	125	5705/FPP	TAVOLO JOYCE PIANO PIETRA	PAG.	108
3660/F	BASE MODULO SWING	PAG.	31	3817/F	POLTRONCINA JOYCE	PAG.	122	5197/F	SEDIA CARAMBOLA	PAG.	124	5709	TAVOLO LEONARDO	PAG.	110
3661/F	BASE MODULO SWING	PAG.	43	3820/F	POLTRONA MOBY DICK	PAG.	154	5198/F	SEDIA CARAMBOLA GIREVOLE	PAG.	130	5710	TAVOLO LEONARDO	PAG.	110
3662/F	MODULO SWING	PAG.	41	3823/F	CHAISE LONGUE JOYCE	PAG.	154	5268/F	SEDIA SCALA	PAG.	133	5712/F	TAVOLO TRIDENT	PAG.	111
3663/F	MODULO SWING	PAG.	41	3848	POLTRONA GIREVOLE DIRETTORIO	PAG.	132	5303/F	SGABELLO ICARO BASSO	PAG.	136	5717/F	TAVOLO MALIBU'	PAG.	112
3664/F	MODULO SWING	PAG.	42	3853	POLTRONA 900 CLUB	PAG.	158	5304/F	SGABELLO ICARO ALTO	PAG.	135	5720/F	TAVOLO CAMPO	PAG.	109
3665/F	MODULO SWING	PAG.	42	3860	POLTRONA VERONA	PAG.	160	5310	SGABELLO DIRETTORIO	PAG.	137	5721	TAVOLO BOOMERANG	PAG.	111
3666/F	MODULO SWING	PAG.	42	3862	POLTRONA GIREVOLE BIEDERMEIER	PAG.	132	5311	SGABELLO BIEDERMEIER	PAG.	137	5722	TAVOLO FLAMINIA	PAG.	112
3667/F	MODULO SWING	PAG.	34	3868	POLTRONA IMPERIA	PAG.	127	5312	SGABELLO BIEDERMEIER	PAG.	137	5723/F	TAVOLO MARILYN ROTONDO	PAG.	109
3668/F	MODULO SWING	PAG.	34	3873	POLTRONCINA BIEDERMEIER	PAG.	159	5315/F	SGABELLO JOYCE	PAG.	135	5724/F	TAVOLO MARILYN OVALE	PAG.	109
3669/F	MODULO SWING	PAG.	34	3878	POLTRONA AURELIA	PAG.	155	5325/N	SGABELLO ZERO	PAG.	135	5726	TAVOLO CAMPIELLO	PAG.	110
3670/F	RIPIANO PER BOISERIE CON CREMAGLIERA	PAG.	34	3880	POLTRONCINA BRAMANTE	PAG.	124	5326	POUF MOENA	PAG.	134	5728/F	TAVOLO ITALO	PAG.	109
3671	CUBO IN FERRO SWING	PAG.	31	3881/A	POLTRONCINA CARTESIA	PAG.	126	5327	POUF DAPHNE	PAG.	134	5729/F	TAVOLO SPIDER	PAG.	109
3672	CUBO IN FERRO SWING	PAG.	35	3882	POLTRONCINA GIREVOLE DIRETTORIO	PAG.	132	5328	SGABELLO MANHATTAN	PAG.	135	5730/F	TAVOLO CARAMBOLA DAMA	PAG.	145
3673/F	PANNELLO BOISERIE SWING	PAG.	35/186	3883	POLTRONA GIREVOLE BIEDERMEIER	PAG.	132	5331	SGABELLO BIEDERMEIER	PAG.	137	5733/F	TAVOLO JOYCE 240	PAG.	108

5734/F	TAVOLO JOYCE ROTONDO 140	PAG.	108
5744	TAVOLO DIRETTORIO	PAG.	113
5768	TAVOLO DIRETTORIO	PAG.	113
5769	TAVOLO LUIGI XV	PAG.	112
5775	TAVOLO BIEDERMEIER	PAG.	112
5776/A	TAVOLO NORD SUD	PAG.	110
5779	TAVOLO BIEDERMEIER	PAG.	113
5782	TAVOLO BIEDERMEIER	PAG.	113
5794/A	TAVOLO AERO	PAG.	111
5795	TAVOLO CARTESIA	PAG.	111
5799	TAVOLO 900	PAG.	112
5801/F	CONSOLLE SWING	PAG.	39/98/148
5812	CONSOLLE BIEDERMEIER	PAG.	148
5815	CONSOLLE BIEDERMEIER	PAG.	148
5818	CONSOLLE CAVALLETTO	PAG.	148
6201/F	LIBRERIA BELLAGIO	PAG.	91
6202/F	LIBRERIA ERRANTE	PAG.	92
6204/F	LIBRERIA PERBACCO	PAG.	90
6205/F	LIBRERIA SWING	PAG.	28/90
6206/F	LIBRERIA SWING	PAG.	90
6292	LIBRERIA BABILONIA	PAG.	92
6298	LIBRERIA BERENICE	PAG.	93
6299/F	LIBRERIA SUPERGIU'	PAG.	91
A010074S	APPENDIABITI INCLINABILE	PAG.	201
A010124S	PORTA CRAVATTE	PAG.	200
A010125S	PORTA PANTALONI	PAG.	200
A010141S	PIEDE ACCIAIO	PAG.	43/63
A010142S	PIEDE ACCIAIO	PAG.	43/63
A010161S	PIEDE OTTONE	PAG.	43/63
A010180S	BARRA TUBOLARE PER SCALA	PAG.	5/76/83/201
A010183S	LED LIBRERIA BIEDERMEIER FS379725	PAG.	201
A010183S	LED LIBRERIA BIEDERMEIER FS3710182	PAG.	201
A010201S	REGGIMENSOLA	PAG.	35
A010202S	STAFFE PER MODULI SOSPESI	PAG.	35
A010203S	CREMAGLIERA DX PER SWING	PAG.	35
A010204S	CREMAGLIERA SX PER SWING	PAG.	35
A010205S	CREMAGLIERA CENTRALE PER SWING	PAG.	35
A010206S	PROFILO LED AL MT/L	PAG.	35/76/201
A010207S	TRASFORMATORE LED	PAG.	35/76/201
A010208S	LED PER ART 3708	PAG.	201
A010209S	LED PER ART 3709	PAG.	201
A010210S	LED PER ART 3712	PAG.	201
A010211S	LED PER ART 3713	PAG.	201
A010212S	LED PER ART 3714	PAG.	201
A010213S	LED PER ART 3721	PAG.	201
A010214S	LED PER ART 3722	PAG.	201
A010215S	LED PER ART 3727	PAG.	201
A010216S	LED PER ART 3728	PAG.	201
A010227S	LED PER MODULO NOVECENTO 3362/F	PAG.	69
A010228S	LED PER MODULO NOVECENTO 3364/F	PAG.	69
A120018S	SPECCHIO INTERNO PER AMADI	PAG.	201
A150001S	MATERASSO MATRIMONIALE 170X195	PAG.	168

A150001S	MATERASSO MATRIMONIALE 180X200	PAG.	168
A150002S	MATERASSO SINGOLO 86X195	PAG.	168
A150002S	MATERASSO SINGOLO 90X200	PAG.	168
A160002S	COPRIMATERASSO SINGOLO	PAG.	201
A160002S	COPRIMATERASSO MATRIMONIALE	PAG.	201
A160006S	RULLO PER LETTO	PAG.	169
A160007S	CUSCINO CON BOTTONI	PAG.	160/169
A160021S	CUSCINO RETTANGOLARE	PAG.	201
A500052S	KIT RITOCOCCO	PAG.	201
FS379725	COMPOSIZIONE BIEDERMEIER	PAG.	72
FS3010186	COMPOSIZIONE DIRETTORIO	PAG.	80
FS3010187	COMPOSIZIONE DIRETTORIO	PAG.	80
FS3012339	COMPOSIZIONE PRESIDENT	PAG.	86
FS3314320	COMPOSIZIONE NOVECENTO	PAG.	66
FS3314322	COMPOSIZIONE NOVECENTO	PAG.	66
FS3314337	COMPOSIZIONE NOVECENTO	PAG.	66
FS3410170	COMPOSIZIONE ZERO	PAG.	52
FS3410174	COMPOSIZIONE SCALA	PAG.	46
FS3410175	COMPOSIZIONE SCALA	PAG.	46
FS3410176	COMPOSIZIONE SCALA	PAG.	46
FS3411047	COMPOSIZIONE SHARK	PAG.	20
FS3414569	COMPOSIZIONE SHARK	PAG.	20
FS3414570	COMPOSIZIONE SHARK	PAG.	20
FS3510177	COMPOSIZIONE MASCHERA	PAG.	10
FS3510178	COMPOSIZIONE MASCHERA	PAG.	10
FS3510597	COMPOSIZIONE MASCHERA SCORREVOLE	PAG.	4
FS3510598	COMPOSIZIONE MASCHERA SCORREVOLE	PAG.	4
FS3510599	COMPOSIZIONE MASCHERA SCORREVOLE	PAG.	4
FS3710182	COMPOSIZIONE BIEDERMEIER	PAG.	72
FS3714238	COMPOSIZIONE ZERO	PAG.	52
FS6214571	LIBRERIA PERBACCO	PAG.	90
S090005S	RIPIANO GUARDAROBA 2P	PAG.	200/201
S090006S	RIPIANO GUARDAROBA 1P	PAG.	201
S100001S	CASSETTIERA PER ARMADI	PAG.	200/201

Il presente listino entra in vigore da **01/02/2023** e annulla e sostituisce tutti i precedenti. Morelato si riserva di modificare, senza preavviso, prezzi e caratteristiche tecniche dei prodotti.

I prezzi indicati sul presente listino **sono** espressi in euro. La collaborazione azienda-rivenditore è regolata sulla base del prezzo netto riservato, aumentato dell'aliquota IVA.

CONDIZIONI DI VENDITA

I prezzi indicati si intendono franco fabbrica (EXW Incoterms) ed i costi di trasporto sono a carico dell'acquirente. La merce viaggia sempre a rischio e pericolo dell'acquirente anche in caso di consegna a porto franco o franco destino. L'acquirente è perciò tenuto ad assicurare la merce viaggiante. Per mobili di seconda o terza qualità con finitura economica sarà applicato lo sconto del 50%. La vendita si intende convenuta con la riserva di proprietà a favore della Morelato, la merce fornita resta pertanto di proprietà della società Morelato srl, ai sensi dell'art. 1523 c.c., sino al completo pagamento del prezzo. Il mancato pagamento anche di una sola rata il cui importo superi l'ottava parte del prezzo convenuto, produrrà l'automatica e immediata risoluzione del contratto e la Morelato avrà facoltà di disporre, mediante ingiunzione, il ritiro della merce fornita e di trattare, a titolo di indennità per uso, deterioramento e spese, gli importi già versati dal compratore fatto salvo l'eventuale risarcimento del danno.

PAGAMENTI

Le modalità di pagamento sono regolate dagli accordi commerciali con la nostra clientela.

Le consegne a Clienti "occasionalni" saranno effettuate esclusivamente con pagamento in contrassegno.

Le consegne ai Clienti che in passato hanno dato origine ad irregolarità amministrative saranno effettuate esclusivamente con pagamento in contrassegno.

ORDINI

Al momento dell'ordine si prega di specificare: quantità, descrizione, codice articolo, codice rivestimento, codice di finitura, indicati in catalogo e listino. Gli ordini devono essere trasmessi direttamente alla Morelato, presso la sua sede ed indirizzo, oppure tramite agente.

Le commissioni si intendono assunte "salvo approvazione della Casa" mentre sono di impegno irrevocabile per il committente.

L'ordine verrà esaminato dall'Ufficio Commerciale e se approvato verrà inviata al Rivenditore una Conferma d'Ordine. Il Rivenditore è tenuto a verificare che i dati riportati corrispondano all'ordine trasmesso. Eventuali discordanze devono essere comunicate entro 8 giorni.

TERMINI DI CONSEGNA

I termini di consegna non sono da intendersi impegnativi, eventuali ritardi di spedizione non daranno luogo a pretese di danni o interessi da parte del Cliente. I tempi di consegna per gli articoli con tessuto o finitura cliente decorrono dall'arrivo del campione o tessuto stesso presso la nostra sede.

PRODUZIONI SPECIALI

L'ufficio Tecnico Morelato è a disposizione della clientela per informazioni tecniche e richieste di fuori standard. La richiesta di produzioni speciali va inviata tramite fax o e-mail alla nostra sede dal Rivenditore, completa di schizzi, misure e descrizione dei materiali. La richiesta viene esaminata dall'Ufficio Tecnico che ne valuta la fattibilità, dopodiché verrà trasmesso al rivenditore un preventivo di spesa. Il preventivo dovrà essere accettato e ritornato alla Morelato.

RECLAMI

I danni causati dal trasporto dovranno essere tassativamente annotati sul documento di trasporto all'atto dello scarico e confermati per iscritto a Morelato entro il termine massimo di 8 giorni dal ricevimento della merce, pena la decadenza di ogni eventuale contestazione.

Spetta al destinatario infatti, controllare le condizioni dell'imballo e la corrispondenza dei colli per quanto scritto sul documento di trasporto. Il trasportatore è responsabile di mancanze o avarie dovute al trasporto. In assenza della sopraindicata procedura la Morelato non effettuerà la sostituzione della merce danneggiata a causa del trasporto.

Non saranno accettati resi di merce se non autorizzati preventivamente. Per eventuali resi, sostituzioni e riparazioni saranno addebitate i costi di trasporto. Non saranno accettati resi di merce fuori standard e con finitura o tessuti a campione. Non si accettano reclami di qualsiasi tipo dovuti ad uso improprio del prodotto e mancata osservanza delle istruzioni e precauzioni d'uso e pulizia.

PREZZI DI LISTINO

I prezzi di listino si riferiscono alle finiture F32/C, F32/A, F32/N, F32/F, F30, F34, F60, F80, F100, F140, F150, F160, F170, F180, F190, F.L.11, F.L.50, F.L.60, F.L.70, F.L.80, F.L.90, F.L.100, F.L.120, F.L.130,F.L.140, F.L.150, F.L.160, F.L.170, F.L.180. Per le finiture FL1, FL2, FL20, FL5, FL21 e finiture personalizzate il prezzo deve essere aumentato del 15%.

I prezzi di sedie, poltrone e divani sono indicati per categoria di tessuto (C) e pelle (D). Se il tessuto è fornito dal cliente deve essere applicato il prezzo della categoria B. Il prezzo dei letti comprende i supporti in doghe di faggio.

Per i rivestimenti in Alcantara il prezzo deve essere aumentato del 15% dalla categoria D.

FORO COMPETENTE

Per ogni contestazione o controversia unico competente sarà l'Autorità giudiziaria del Foro di Verona.

MATERIALI – MANUTENZIONE E PULIZIA

RISPETTO PER LA NATURA

Per la costruzione dei mobili Morelato impiega legni provenienti da coltivazioni programmate, estranee al disboscamento selvaggio. I mobili sono destinati a durare molto a lungo, pertanto non presentano il problema del riciclaggio tipico dei prodotti di qualità scadente.

LEGGI

Il legno è un prodotto naturale. Ogni pezzo possiede un proprio colore e una propria struttura. Differenze di tono delle venature del legno non sono da considerarsi motivo di reclamo trattandosi solo di possibili diversità di colore. Gli articoli acquistati in tempi diversi potrebbero rivelare differenze di colore e tonalità. I materiali contenuti nel campionario sono quindi indicativi, e piccole differenze di tonalità non sono motivo di reclamo. Per la manutenzione e pulizia usare prodotti liquidi neutri per vetro, non usare diluenti, alcol, prodotti abrasivi o solventi.

Il legno massello viene utilizzato tenendo conto delle sue proprietà, al fine di garantire la massima funzionalità del manufatto nel tempo (portata, stabilità, resistenza, estetica). Il legno multistrati controplaccato è costituito da fogli di legno disposti con le fibre perpendicolari tra loro e pressati. Le facce esterne sono rivestite in legno pregiato con una doppia impiallacciatura in senso contrario. Da questa particolare disposizione deriva una maggiore resistenza dovuta al reciproco sostegno delle fibre. Il legno listellare è formato da listelli appunto di legno massello accostati tra loro e pressati tra due fogli di legno compensato. Come nel legno multistrati le facce esterne sono rivestite in legno pregiato con una doppia impiallacciatura di senso contrario, per garantire una maggiore resistenza.

Il legno tamburato è formato da un telaio in legno massello che racchiude un'anima a "nido d'ape". Viene impiegato per dare leggerezza alle ampie superfici degli armadi guardaroba.

La Morelato non utilizza pannelli in truciolato per la costruzione dei propri mobili.

LE TECNICHE DI COSTRUZIONE

I più apprezzabili particolari dei mobili Morelato sono gli incastri. Ogni mobile è tenuto unito da un sistema di incastri, eseguiti con l'impiego di frese e contro-frese, che conferiscono una preziosità artigianale unica. Altri rari particolari sono le scalette reggi-ripianti in legno, l'incastro a "coda di rondine" dei cassetti, l'incastro a "pettine" dei battenti di rinforzo della seduta delle sedie, ecc.

LA LUCIDATURA

Per la lucidatura Morelato impiega esclusivamente i migliori prodotti presenti sul mercato internazionale. Le superfici lucidate sono realizzate con vernici ecologiche ad alta resistenza allo sfregamento che garantiscono la stabilità del colore.

Le finiture attualmente in uso sono quelle descritte nella "Cartella Tessuti e Finiture". Per finiture particolari il Cliente dovrà inviare un campione o un componente di altro mobile al quale fare riferimento.

Gli articoli acquistati in tempi diversi potrebbero rivelare differenze di colore e tonalità. Le finiture contenute nel campionario finiture sono quindi puramente indicative. Per la manutenzione e pulizia usare prodotti liquidi neutri per vetro, non usare diluenti, alcol, prodotti abrasivi o solventi.

I TESSUTI

L'imbottitura e rivestimento delle sedie, poltrone e divani è a tutt'oggi una lavorazione artigianale e manuale. I tessuti e le pelli attualmente disponibili sono quelli descritti nella "Cartella Tessuti e Finiture". Il Cliente può scegliere tra i tessuti disponibili o inviare alla Morelato il suo tessuto preferito.

Pelli e cuoio: la Morelato usa esclusivamente materiali e pelli di altissima qualità, lavorata ancora oggi secondo i dettami della più antica e nobile tradizione italiana. Essendo il cuoio materiale naturale non può mai presentare identità di colore e struttura: queste relative differenze sono garanzia della totale qualità del prodotto usato. La superficie rugosa non è da considerarsi difetto, in quanto all'origine non tutti i pellami possono presentare l'uniformità, quindi la piccola piega che si può trovare è sinonimo di autenticità. Per la pulizia delle parti in pelle si consiglia di usare prodotti specifici. Si informa che pelle e cuoio non sono idrorepellenti.

Tessuti: i colori dei tessuti presenti nel campionario sono indicativi: è infatti tecnicamente impossibile mantenere nel tempo le stesse tonalità di colore. Si declina ogni responsabilità per accoppiamenti di imbottiti rivestiti in tessuto, acquistati in tempi diversi.

Per la pulizia, dei prodotti imbottiti non sfoderabili, si consiglia di spruzzare la superficie con schiuma a secco specifica per mobili imbottiti e spazzolare con cura, ma non energicamente.

CERTIFICAZIONE DI GARANZIA

Il Certificato di Garanzia accompagna ogni mobile e tutela il Cliente nel caso si riscontrino dei difetti al ricevimento. Vengono forniti al Cliente anche semplici consigli per il migliore utilizzo del mobile, la sua manutenzione e la protezione dai possibili danni eventualmente arrecati da un ambiente non idoneo.

CERTIFICAZIONE ISO 9001

La Morelato è un'azienda certificata da ICILA (Istituto per la Certificazione delle Imprese dell'Arredamento e del Legno) con certificato n° 80 del 1997. La produzione dei mobili è conforme agli standard qualitativi del sistema internazionale UNI EN ISO 9001

CERTIFICAZIONE GOST-R

La ditta Morelato è certificata Gost-r - N° POCC IT.AE10 .BO2119

PROVE DI LABORATORIO

I mobili sono sottoposti a test periodici in laboratori specializzati per verificare che le caratteristiche e la funzionalità si mantengano nel breve, medio e lungo termine. I test misurano: l'adesione della lucidatura alle superfici, la resistenza delle sedie, indagini sui difetti, ecc.

STRUMENTI DI VENDITA

Offrono informazioni e suggerimenti per orientare la clientela nell'ampia gamma di proposte della Morelato. Attualmente sono disponibili: il Catalogo Tecnico, la Cartella Tessuti e Finiture, il Listino di Vendita, la Monografia Aziendale e il Depliant. È attivo il sito www.morelato.it. Se desiderate comunicare con l'azienda in rete l'indirizzo e-mail è morelato@morelato.it oppure export@morelato.it, per l'ufficio vendite ordini@morelato.it, per l'amministrazione amministrazione@morelato.it

INDICAZIONI E PRECAUZIONI D'USO

Sedie: la sedia va utilizzata con tutte le gambe o le sue parti predisposte appoggiate al pavimento. Non salire con i piedi sulla sedia. Non lasciare esposta la sedia alle intemperie. Evitare di intervenire per manutenzioni sui componenti della sedia, se l'operazione non viene eseguita da una persona esperta; per ogni evenienza contattare il rivenditore o l'Ufficio Tecnico Morelato.

Eventuale presenza di odori particolari emessi dal prodotto appena tolto dall'imballo non costituisce fonte di pericolo e scompare entro poche ore dalla sua esposizione in ambiente arieggiato.

Per la pulizia attenersi alle specifiche indicazioni in "Manutenzione e Pulizia".

Una volta dismesso il prodotto o i suoi componenti non vanno dispersi nell'ambiente ma conferiti ai sistemi pubblici di smaltimento.

Tavoli: non salire con i piedi sul tavolo. Non caricare il tavolo sui bordi con pesi eccessivi (soprattutto i modelli a supporto centrale e quelli allungabili, nella condizione allungati) per evitare il ribaltamento. Evitare gli urti contro superfici vetrate. Evitare di intervenire per manutenzioni sui componenti del tavolo, se l'operazione non viene eseguita da una persona esperta; per ogni evenienza contattare il rivenditore o l'Ufficio Tecnico Morelato. Evitare che i piani rimangano a contatto con acqua o altri liquidi, anche per brevi periodi.

I mobili in legno non devono essere posti in prossimità di fonti di calore superiori ai 45 gradi.

Non esporre alla luce diretta del sole. Eventuale presenza di odori particolari emessi dal prodotto appena tolto dall'imballo non costituisce fonte di pericolo e scompare entro poche ore dalla sua esposizione in ambiente arieggiato.

Per la pulizia attenersi alle specifiche indicazioni in "Manutenzione e Pulizia".

Una volta dismesso il prodotto o i suoi componenti non vanno dispersi nell'ambiente ma conferiti ai sistemi pubblici di smaltimento.

La Morelato non si assume alcuna responsabilità per un uso improprio del prodotto.

This price list comes into force **from 01/02/2023** and substitutes all previous price lists. Morelato has the right to modify prices and characteristics of its products without advance notice.

The prices indicated on the present price list **are** expressed in Euro. The co-operation between the company and dealer is based on the net price and VAT must be paid in the country where the goods are destined.

SALES CONDITIONS

All indicated prices are ex-factory prices (EXW Incoterms). Shipment is charged to the consignee. The goods always travel at the risk and peril of the purchaser even if they are sold free port or shipped to free destination. The purchaser is therefore obliged to insure the traveling goods. For furniture of second or third quality with a cheap polish a 50% discount is applied. Payment conditions are established by a commercial agreement with our customers. All sales are conditional sales in favour of Morelato. All supplied furniture remains property of Morelato, according to art. 1523 of the Italian Civil Code until the furniture has been completely paid for. Even if only one instalment has not been paid for and the amount involved is more than one eighth of the agreed price of the item, the sales contract will be cancelled and Morelato has the right, by injunction, to collect the supplied furniture and to keep the paid instalments as an indemnity for the use and loss in value of the furniture and for the costs involved, unless the customer is willing to pay the eventual indemnity

PAYMENT

Payment conditions are established by a commercial agreement with our customers. Consignment to occasional customers will only be effected with payment at consignment.

Consignment to customers who in the past have caused administrative irregularities will be effected only with payment at consignment.

ORDERS

When placing an order customers are asked to specify: quantity, description, item number, and fabric or leather code, the code of the finish, as indicated on the catalogue and price list. All orders must be forwarded directly to Morelato, at our factory or office, to our address, or to our agent.

All orders are considered accepted "except for company approval", while they are binding for the purchaser.

The order will be analyzed by the sales department and when approved the purchaser will receive an order confirmation. The purchaser has to control the order details. Eventual mistakes will have to be communicated within 8 days.

CONSIGNMENT TERMS

Consignment terms are not binding and for eventual delays no damage or interest claims by the customer are accepted.

Consignment terms for goods with customer fabric or customer finish are calculated from the arrival date of the fabric or finish sample at our premises

CUSTOMIZED ITEMS

The Morelato Technical Department is at customer disposal for technical information as well as requirements for customized items. Requirements for customized items are to be sent by the dealer to our premises by fax or e-mail including drawings and sizes and material description. The request will be examined by our Technical Department and if it is technically possible to produce the required item a pre-emption is sent. If the pre-emption is accepted it has to be signed by the customer and send back to Morelato.

COMPLAINTS

Damages caused by transport must be indicated on the delivery note when the goods are unloaded and a written confirmation of the damage must be sent to Morelato within 8 days from receipt of the goods if not damage claims will be considered null and void.

Customers must inspect the conditions of the packing and check that the number of boxes corresponds to the number indicated on the delivery note. The forwarder is responsible for claims of shortage and damage caused by transport . If the indicated procedure is not respected Morelato will not substitute goods damaged by transport.

Goods cannot be returned without authorisation by Morelato on beforehand. Transport costs for goods sent back for replacement or repair are on customer charge. Morelato does not accept replacement of customized items or with customer fabric or sample finish.

Complaints of any kind caused by improper use of the product or by not respecting the instructions regarding use, cleaning and maintenance are not accepted.

PRICES ON THE PRICE LIST

The prices refer to the F32/C, F32/A, F32/N, F32/F, F30, F34, F60, F80, F100, F140, F150, F160, F170, F180, F190, F.L.11, F.L.50, F.L.60, F.L.70, F.L.80, F.L.90, F.L.100, F.L.120, F.L.130,F.L.140, F.L.150, F.L.160, F.L.170, F.L.180 finishings. For the FL1, FL2, FL20, FL5, FL21 as well as customized finishings an additional 15% must be added to the indicated price. Upholstered items come in two different price categories: fabric (C) and leather (D).

Price category B is used when the fabric is supplied by the customer. The prices of the beds include slats of beech wood.

For Alcantara coatings an additional 15% must be added to the category D indicated price.

JURISDICTION

The court of Verona will have exclusive jurisdiction over any disputes or controversies.

MATERIALS – MANTAINANCE AND CLEANING

RESPECT FOR NATURE

Morelato uses for the production of its furniture only wood coming from plantations thus avoiding deforestation. As Morelato furniture lasts over the years also the problem of the recycling of wood , typical for low quality furniture is avoided.

WOOD

Wood is a natural material. Each piece of wood has its own colour and vain pattern. Differences in the vain pattern are no reason for complaint as their outcome is a different colour shade. Small shade differences are no grounds for complaint. Never use thinners, alcohol, chemical abrasives or solvents for the maintenance and cleaning.

For all frame parts Morelato uses solid wood, which guarantees the functionality (endurance, stability, aesthe-tics) of the product over the years. For some of the surfaces veneered panels of multilayered wood are used. Each layer of wood is pressed in a 180° position upon the other so that the different layers support each other and deformation due to changes in temperature and humidity are avoided. Also other panels composed of lists of wood are used for the surfaces. They have a double counter-pressed external veneer. For the large surfaces such as the wardrobe doors, Morelato uses hollow wood panels. The frames are made of solid wood while inside a honey-bee structure reduces the weight of these panels. Morelato does not use any chipboard panels in its production.

CONSTRUCTION TECHNIQUES

For the assembly of its furniture Morelato uses a joint technique. The pieces of each item are joined thanks to the mill cutting and counter cutting so that they fit perfectly. This artisan technique increases the value of the furniture. Other peculiarities are the adjustable wooden shelf supports, the dovetail and the comb joint, which enforce the seats of the chairs.

THE POLISHING

For the finishing Morelato uses the best products available on the market. Surfaces are polished with highly resistant ecological varnish able to guarantee the colour over the years. Samples of the different colours of finishing can be found in our fabric and wood sample folder. For customized finishing a colour sample or another furniture component as a reference is required.

Pieces of furniture purchased at different moments may present differences colour and shades. Never use thinners, alcohol, chemical abrasives or solvents for the maintenance and cleaning.

THE FABRICS

The upholstery of chairs and sofas is still a artisan craft. For the upholstered items it is possible to select a fabric from the sample folder or the customer can send us his fabric for the upholstery.

Leather: Morelato uses exclusively high quality materials and leather for a production which still respects the best Italian artisan tradition. As leather is a natural product its colour and structure will never be uniform: the small differences guarantee the total quality of the material used. A wrinkled surface is not a defect as leather cannot be uniform, thus each small wrinkle is a sign of authenticity. For the cleaning of the leather surfaces specific leather cleaning products must be used. We inform our customers that leather is not water proof.

Fabric: The colours of the fabric in the sample folder are approximate: it is in fact impossible in the course of time to maintain the colour shade. We decline any responsibility for the colour-matching of articles upholstered with fabric acquired at different moments.

To clean items with fixed fabric: use a dry foam spray for upholstery and brush with care but not too energetically.

To clean items with removable lining: dry-wash the fabric or wash at low temperature (max. 30°) using a short programme and soft soap. Do not wring or centrifuge and let the fabric dry in the shadow. If necessary iron with a steam iron at low temperature.

WARRANTY CERTIFICATE

Each piece of furniture is supplied with a warranty certificate and guarantees the customer when the furniture arrives in case of production defects. The customer also receives simple instructions how to use the piece of furniture, its maintenance and protection from eventual damaged caused by unsuitable environmental conditions

ISO 9001 WARRANTY

Morelato is a ICILA (Istitute for the certification od woodworking and furniture industries) certified company with certificate n° 80 from 1997. The production of our furniture meets the international UNI EN ISO 9001 quality standards

GOST-R CERTIFICATE

Morelato is a Gost-r - N° POCC IT.AE10 .BO2119 certified company

LABORATORY TESTS

Our furniture is frequently tested by qualified laboratories which verify its characteristics and functionality on short- medium- and long terms. The tests verify the varnish adhesion, durability of the seat, research on complaints, etc.

DOCUMENTATION

The documentation helps the customer by giving information about the wide range of Morelato products. At the moment the following documentation is available: Technical catalogue, Wood- and Fabric Sample Folder, Price list, the History of the Morelato Company and the brochure. Further information is available at our website: www.morelato.it.

E-mails can be sent to morelato@morelato.it or export@morelato.it, to the sales department ordini@morelato.it, and to the administration amministrazione@morelato.it.

OPERATING INSTRUCTIONS AND PRECAUTIONS

Chairs: chairs must be used with all four legs or bearing parts placed on the ground. Do not stand on a chair. Do not leave the chair outside. Avoid any maintenance interventions on parts of the chair if not executed by professionally skilled people; for any further information please contact the Morelato dealer or the Morelato Technical Department.

An eventual particular smell coming from the furniture when it has just been unpacked is not dangerous and disappears after a while when placed in a ventilated room.

For the cleaning of the furniture please keep to the "Maintenance and Cleaning" instructions.

When the product or its components are no longer used, they must not be abandoned in nature but have to be taken to specific waste processors.

Tables: do not stand on a table. Do not put excessive weight on the edges of the top especially for models with central legs or extendible tables, when extended) Avoid blows to glass surfaces. Avoid maintenance interventions on parts of the table if not by professionally skilled people, for any further information please contact the Morelato dealer or the Morelato Technical Department. For table tops contact with water or other liquids (even shortly) must be avoided.

An eventual particular smell coming from the furniture when it has just been unpacked is not dangerous and disappears after a while when placed in a ventilated room.

For the cleaning of the furniture please keep to the "Maintenance and Cleaning" instructions.

When the product or its components are no longer used, they must not be abandoned in nature but taken to specific waste processors.

Morelato is not responsible for an improprer use of its products.

Настоящий прайс-лист вступает в силу с 01.02.2023 года, отменяя действие всех предыдущих. Morelato оставляет за собой право вносить изменения в стоимость и технические характеристики продукции без предупреждения.

Цены настоящего прайс-листа указаны в Евро. Сотрудничество фабрики с представителями розничной торговли осуществляется по ценам нетто.

УСЛОВИЯ ПРОДАЖИ

Продукция фабрики поставляется на условиях франко-фабрика, то есть цены указаны без учета транспортных расходов. На мебель второго и третьего сорта с экономичным вариантом тонировки распространяется скидка 50%. Согласно статье 1523 Гражданского кодекса товар считается собственностью Morelato s.r.l до полной его оплаты покупателем.

Отсутствие оплаты суммы, составляющей более одной восьмой стоимости, автоматически аннулирует контракт. В такой ситуации Morelato s.r.l имеет право изъятия товара по предписанию суда и право рассматривать уже внесенные за товар денежные средства в качестве компенсации за расходы, использование и износ товара.

ОПЛАТА

Условия оплаты продукции регулируются коммерческими соглашениями с нашими клиентами.

Заказы клиентов, сотрудничающих с фабрикой не на постоянной основе, принимаются только на условии стопроцентной предоплаты.

Заказы клиентов, нарушивших в прошлом административные требования фабрики, принимаются только на условии стопроцентной предоплаты.

ЗАКАЗЫ

При составлении заказа необходимо указывать номер артикула, его описание, номер артикула обивочного материала, код тонировки согласно каталогу и прайс-листу Morelato и количество заказываемых артикулов. Заказы следует направлять через официальное представительство Morelato на территории СНГ, East Euro Company.

Заказ будет принят на рассмотрение Коммерческим департаментом и, в случае принятия, закреплен соответствующим документом: Подтверждением заказа. Заказчик должен проверить документ и подтвердить соответствие всех данных первоначальному заказу. Уточнения и корректировки Подтверждения заказа могут быть переданы на фабрику в течение восьми дней.

СРОКИ ПРОИЗВОДСТВА

Сроки производства должны считаться ориентировочными, возможные задержки производства не считаются основанием для претензий со стороны клиента.

Отсчет сроков производства артикулов, для обивки которых используется материал клиента, начинается с момента поступления обивочного материала на фабрику.

НЕСТАНДАРТНОЕ ПРОИЗВОДСТВО

Технический департамент Morelato обязуется предоставлять запрашиваемую клиентом информацию технического характера. Запрос на нестандартные модели, содержащий эскизы, размеры и описания материалов, должен быть отправлен по факсу или электронной почте на адрес представительства фабрики. Технический департамент обязуется рассмотреть возможность изготовления и, в случае положительного решения, выслать предложение по стоимости заказа. В случае согласия клиента с условиями производства, предложение должно быть подтверждено и отправлено Morelato.

РЕКЛАМАЦИИ

Повреждения, полученные в процессе транспортировки, должны быть в обязательном порядке описаны на отгрузочном документе сразу после отгрузки, документ следует выслать на фабрику Morelato в течение восьми дней с момента получения товара, в противном случае претензия рассмотрена не будет.

Получатель товара должен проверить состояние упаковочного материала и соответствие количества мест оговоренному в отгрузочных документах. В случае несоответствия количества мест или обнаружения повреждений, связанных с транспортировкой, ответственность несет транспортная компания клиента. При отсутствии необходимой документации по транспортным повреждениям Morelato не будет рассматривать возможность замены поврежденной в ходе транспортировки мебели.

Мебель, возвращаемая по каким-либо причинам на фабрику, будет принята только в случае предварительного согласования. В ситуациях возврата, замены или реставрации поврежденной мебели фабрика не

берет на себя транспортные расходы. Возврат нестандартной мебели или мебели, при изготовлении которой использовались обивочные материалы клиента или образцы тонировки дерева клиента, невозможен.

Рекламации на мебель, поврежденную в результате неправильной эксплуатации или неправильного ухода, приниматься не будут.

ЦЕНЫ ПО ПРАЙС-ЛИСТУ

Цены прайс-листа распространяются на мебель в следующих отделах: F32/C, F32/A, F32/N, F32/F, F30, F34, F60, F80, F100, F140, F150, F160, F170, F180, F190, F.L.11, F.L.50, F.L.60, F.L.70, F.L.80, F.L.90, F.L.100, F.L.120, F.L.130, F.L.140, F.L.150, F.L.160, F.L.170, F.L.180 и персонифицированные тонировки распространяется наценка 15%. Цены стульев, кресел и диванов варьируются в зависимости от категории обивки: ткань (C) или кожа (D). В случае обивки из материала клиента, следует ориентироваться на стоимость категории В. В стоимость кроватей всегда включена стоимость решетки из дерева бука.

Для покрытий Алякантара, Цена должна быть увеличена на 15% от категории D.

СУДЕБНЫЕ ОРГАНЫ

Единственным возможным судебным органом для обращения в случае возникновения спорных вопросов считается Суд г.Вероны.

МАТЕРИАЛЫ. УХОД И ЧИСТКА

СОХРАНЕНИЕ ПРИРОДЫ

Для производства мебели Morelato использует дерево с запрограммированных лесопосадок, не связанных с вырубкой естественных лесов. Мебель Morelato прочна и долговечна, но, в отличие от продукции низшего качества, может подвергнуться вторичной переработке.

ДЕРЕВО

Дерево и тонировочные покрытия. Дерево – натуральный материал. Каждый элемент уникален: он имеет свой цвет и структуру. Разница в оттенке не может считаться основанием для рекламации. Таким образом, образцы материалов следует считать ориентировочными. Тонировка осуществляется экологически чистой краской высокой прочности, что гарантирует и стойкость цвета. Мебель, приобретенная в разное время, может отличаться по цвету. Для ухода за мебелью противопоказано использование растворителя, спирта и абразивов. Массив используется с учетом особенностей материала, что гарантирует максимальную функциональность изделия (прочность, устойчивость, эстетические особенности). Многослойная клееная фанера производится из прессованных фанерных листов; направление волокон каждого листа перпендикулярно предыдущему. Фасады покрыты двойным слоем шпона ценных пород дерева; направление волокон верхнего слоя перпендикулярно нижнему, обеспечивая максимальную прочность покрытия.

Клееная древесина производится из реек из массива, соединенных между собой, и спрессованных между двумя фанерными листами. Фасады покрыты двойным слоем шпона ценных пород дерева; направление волокон верхнего слоя перпендикулярно нижнему, обеспечивая максимальную прочность покрытия.

Тамбурат состоит из деревянной рамы из массива, внутри которой находятся рейки, расположенные по типу пчелиных сот. Такая конструкция используется при изготовлении мебели для которой помимо прочности важна и легкость. Morelato не использует в производстве свое мебели ДСП.

ТЕХНИЧЕСКИЕ ОСОБЕННОСТИ

Одна из самых ценных особенностей мебели Morelato это соединение деталей. Все детали мебели крепятся между собой при помощи специальной системы креплений, выполненных с использованием фрез и встречного фрезирования, которые передают уникальную ценность ручной работы итальянских мастеров. Еще одна особенность это деревянные полка-держатели, соединение ящиков «ласточкин хвост», соединение «расческа» для укрепления элементов сидения стула, итд.

ПОЛИРОВКА

Для полировки Morelato использует только самые лучшие материалы, присутствующие на международном рынке. Для полировки используются экологически чистые лаки, устойчивые к царапинам, и гарантируют устойчивость цвета. Все используемые отделки и их описание

находятся в папке с образцами тканей и отделок "Cartella Tessuti e Finiture". Для отделки по желанию клиента, необходимо отправить образец, или составляющую мебели. Мебель приобретенная в различное время может отличаться по цвету и тону. Отделки различных пород дерева представленные в образцах примерные. По уходу и эксплуатации необходимо использовать нейтральные жидкие чистящие средства для стекла, не использовать спирт, абразивные вещества и растворители.

ТКАНИ

Обивка стульев, кресел и диванов выполняется вручную. Все используемые образцы представлены в папке тканей и отделок "Cartella Tessuti e Finiture". Клиенты могут выбрать как представленные в каталоге образцы так и собственные.

Кожа и ткани. В производстве нашей мебели используются ткани и кожи высшего качества. Кожа, будучи натуральным материалом, может отличаться в оттенках и фактуре. Для чистки кожаных вставок следует использовать специальные средства. Естественная неоднородность поверхности кожи дефектом не считается.

Оттенки ткани, представленной в образцах, считаются ориентировочными, так как изготовление идентичных по цвету материалов технически невозможно. Фабрика считает себя в праве отклонить претензии по несоответствию в оттенке обивочных материалов мебели, приобретенной в разное время.

Для чистки мягкой мебели с несъемными чехлами следует использовать пенные моющие средства.

Для съемных чехлов: химчистка или деликатная машинная стирка при максимальной температуре в 30°, нейтральными моющими средствами. Не отжимать, не подвергать воздействию прямых солнечных лучей во время сушки. В случае необходимости гладить на низкой температуре.

СЕРТИФИКАТ КАЧЕСТВА

Вся производимая мебель имеет сертификат качества и является документом защиты прав потребителя при обнаружении дефектов мебели при ее получении. Кроме того клиентам так же предоставляется информация по уходу и эксплуатации для избежания дефектов возникающих при неправильном использовании.

МЕЖДУНАРОДНЫЙ СЕРТИФИКАТ КАЧЕСТВА 9001

Фабрика Morelato сертифицирована ICILA (Институт по Сертификации Мебельных Фабрик и Деревя) N 80 OT 1997. Производство мебели соответствует международному стандарту качества UNI EN ISO 9001

СЕРТИФИКАТ ГОСТ-R

Фабрика Morelato сертифицирована ГОСТ-R - N° РОСС IT.AE10 .BO2119

ЛАБОРАТОРНЫЕ ИСПЫТАНИЯ

Вся продукция подвергается периодическому тестированию для выявления характеристик функциональности в течение длительного периода использования мебели. Тесты выявляют качество полированной поверхности, прочность стульев, итд.

ИНСТРУМЕНТЫ ПРОДАЖ

Всем клиентам фабрика Morelato оказывает широкую информационную поддержку: технический каталог, папка с образцами тканей и отделок, прайс лист, брошюры, история фабрики. Действует сайт www.morelato.it Электронный адрес фабрики morelato@morelato.it или export@morelato.it, amministrazione@morelato.it, ordini@morelato.it.

СПОСОБ ПРИМЕНЕНИЯ

Стулья: стул должен касаться всеми ножками пола. Не вставать на стул. Не подвергать стул неблагоприятному воздействию окружающей среды. Не осуществлять ремонт составляющих деталей самостоятельно, при необходимости обращаться к продавцу или в технический офис Morelato. Для ухода и чистки следовать инструкциям согласно разделу «Уход и эксплуатация». Вышедшая из употребления продукция или ее составляющие должны быть направлены на переработку.

Столы: не вставать на стол. Не грузить стол близко к краю (особенно модели с ножкой по центру, и раздвижные столы в раздвинутом виде) во избежание опрокидывания. Беречь от ударов по стеклянной поверхности. Не осуществлять ремонт составляющих деталей самостоятельно, при необходимости обращаться к продавцу или в технический офис Morelato. Беречь от контакта с водой или другими жидко-

стями даже на короткий промежуток времени. Мебель не должна находиться в помещении, температура которого не превышает 45 градусов тепла. Не подвергать прямому воздействию солнечных лучей. Для ухода и чистки следовать инструкциям согласно разделу «Уход и эксплуатация».

Вышедшая из употребления продукция или ее составляющие должны быть направлены на переработку.

Фабрика Morelato не берет на себя ответственность за использование не по назначению.



SEDE E STABILIMENTO

LOC. VALMORSEL, 540
37056 SALIZZOLE - VERONA
TELEFONO 045 695 40 01
TELEFAX 045 695 40 30

SHOW ROOM

PALAZZO TAIDELLI
CORSO VITTORIO EMANUELE, 61
37058 SANGUINETTO - VERONA
TELEFONO 0442 36 52 50
TELEFAX 0442 36 52 44

WWW.MORELATO.IT
MORELATO@MORELATO.IT



VILLA DIONISI
LOC. CA' DEL LAGO, 70
37053 CERA - VERONA
TELEFONO 0442 36 51 12
TELEFAX 0442 36 52 44

WWW.FONDAZIONEALDOMORELATO.ORG

PRODOTTO IN ITALIA

