

**kettal**



04 – 15

Plumon

16 – 25

Giro

26 – 31

Grand Bitta

32 – 35

Tou

36 – 39

Altar

40 – 45

Pad

46 – 49

Arc

50 – 55

Paladin

56 – 61

Superfan

62 – 71

Base Kitchen

72 – 77

Hydroponic Garden



# Plumon, by Patricia Urquiola

The new outdoor family designed by Patricia Urquiola for Kettal is based on the concept of clothing, on dressing and undressing furniture. Adopting a tailoring approach, Patricia Urquiola designs the new family with a reference to the characteristic Brazilian spirit, which lives in abundant, roomy, comfortable furnishings, somehow evocative of distant landscapes and cultures. For Plumon, Urquiola designs a light structure, on which a tailored and padded dress is 'moored', wrapped. This

ribbed padding, characterized by stitching, as well as being an aesthetic figure, fulfills the comfort of the product. It is the fit that guides the aesthetics. With a few simple gestures, the dress is placed on the rigid teak structure and embraces it. An extreme ease of use that becomes a real plus for an outdoor collection. A comfort that is also emphasized visually, thanks to the padded dress that generously also embraces the armrests and the outside of the backrest.













3 Seaters Sofa

KS7400500

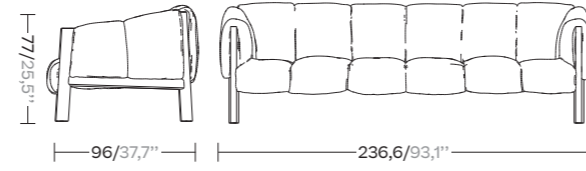

Dining Armchair

KS7400600/KS7401900

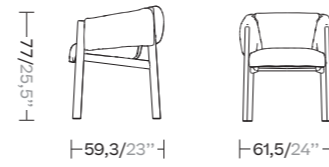

Central table

KS7400800

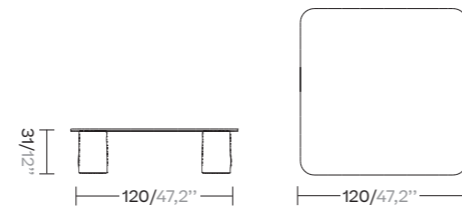

Side table

KS7400300

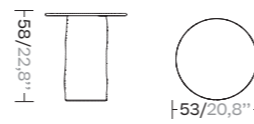



# Giro, by Vincent Van Duysen

The initial and core idea and research behind this collection was about the rope, using it in a different way by sewing them together in order to create the shape of the product itself. A big source of inspiration has been the Orkney Chair. As a great example of vernacular product design, this classic has inspired me to draw inspiration from the past with an eye to today's and Kettal's technology expertise. Whereas in the Orkney the rope was made of real ropes, Giro hinges on the flexibility of recycled polypropilente rope and

on the necessity to produce such a collection industrially. There is a respect for the tradition and craftsmanship but translated to an actual modern up to date version taking all the profit of the actual technology and know-how of Kettal. Based on a natural material to a very sustainable material that can face all kind of weather.







3 Seaters Sofa

KS7402300

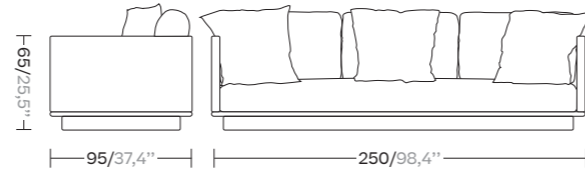

Seater Left or Right Corner module connection

KS7402700/KS7402800

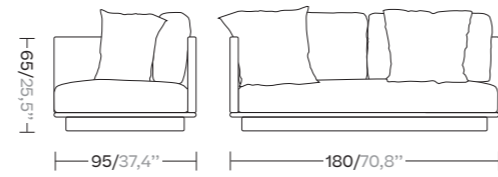

Seater Center Module

KS7402600

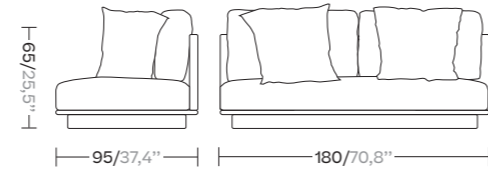

1-seater sofa

KS7402200

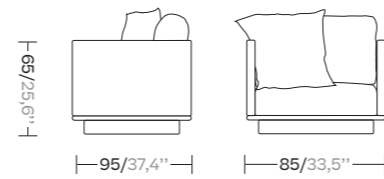



Centre Table ø90

KS7403000

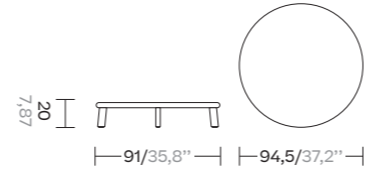

Centre Table ø135

KS7403100

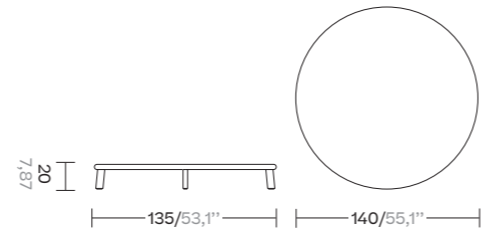

Low Side Table

KS7400900

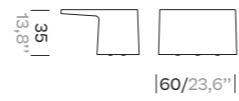

High Side Table

KS7401000

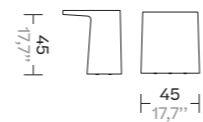

Dining Tables

2 sizes

220x100: KS7403200  
290x100: KS7403300

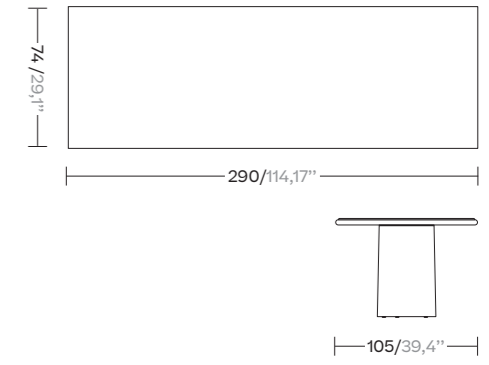

Side Table

KS7402900

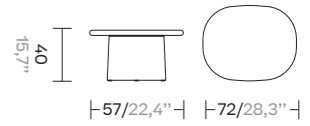



# Grand Bitta, by Rodolfo Dordoni

Grand Bitta is characterized by a combination of aluminum and teak legs, seats of braided polyester and comfortable cushions, with teak or stone table tops - all while using all waterproof materials. "The intention of the designer was to create dense braiding that would

still let the air through, reminiscent of the braiding of the ropes used to moor boats (hence the name Bitta, which means 'mooring' in Italian), which makes the pieces look lightweight but, at the same time, they look just like cozy nests in natural colors to sit back and relax in."







3-seater sofa

KS7003200

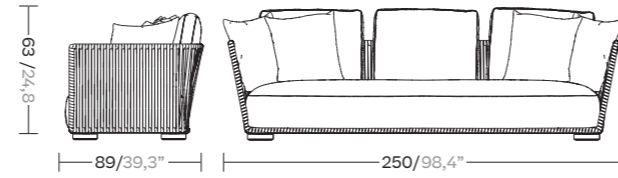

Central module

KS7003500

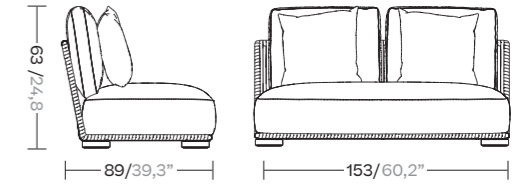

2-seater sofa

KS7003100

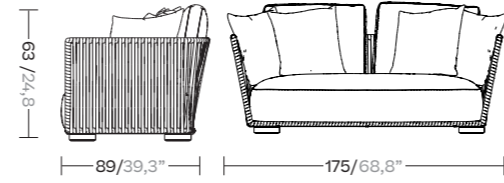

Centre Table

KS7002400



Left module

KS7003300

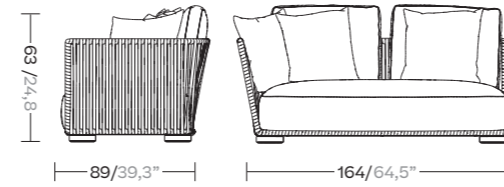

Right module

KS7003400

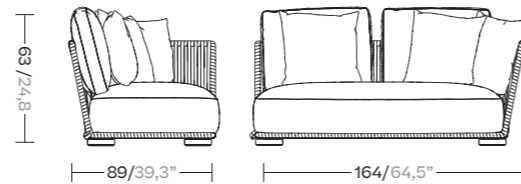



# Tou, outdoor version by Naoto Fukasawa

Tou is our modest tribute to the ancient handicraft of rattan and reed wickerwork, an essential element in the development of both Western and Eastern cultures. Historically, it has been used for all kinds of domestic utensils, furniture and more.

The manufacture combines traditional manual techniques with much more industrial processes. Instead of using the most common form of weaving,

we use striped vertical lines, which are lighter and much more expressive than mesh. The outline is smooth and soft, following the natural shapes provided by the material.



Club Armchair

KS6700200

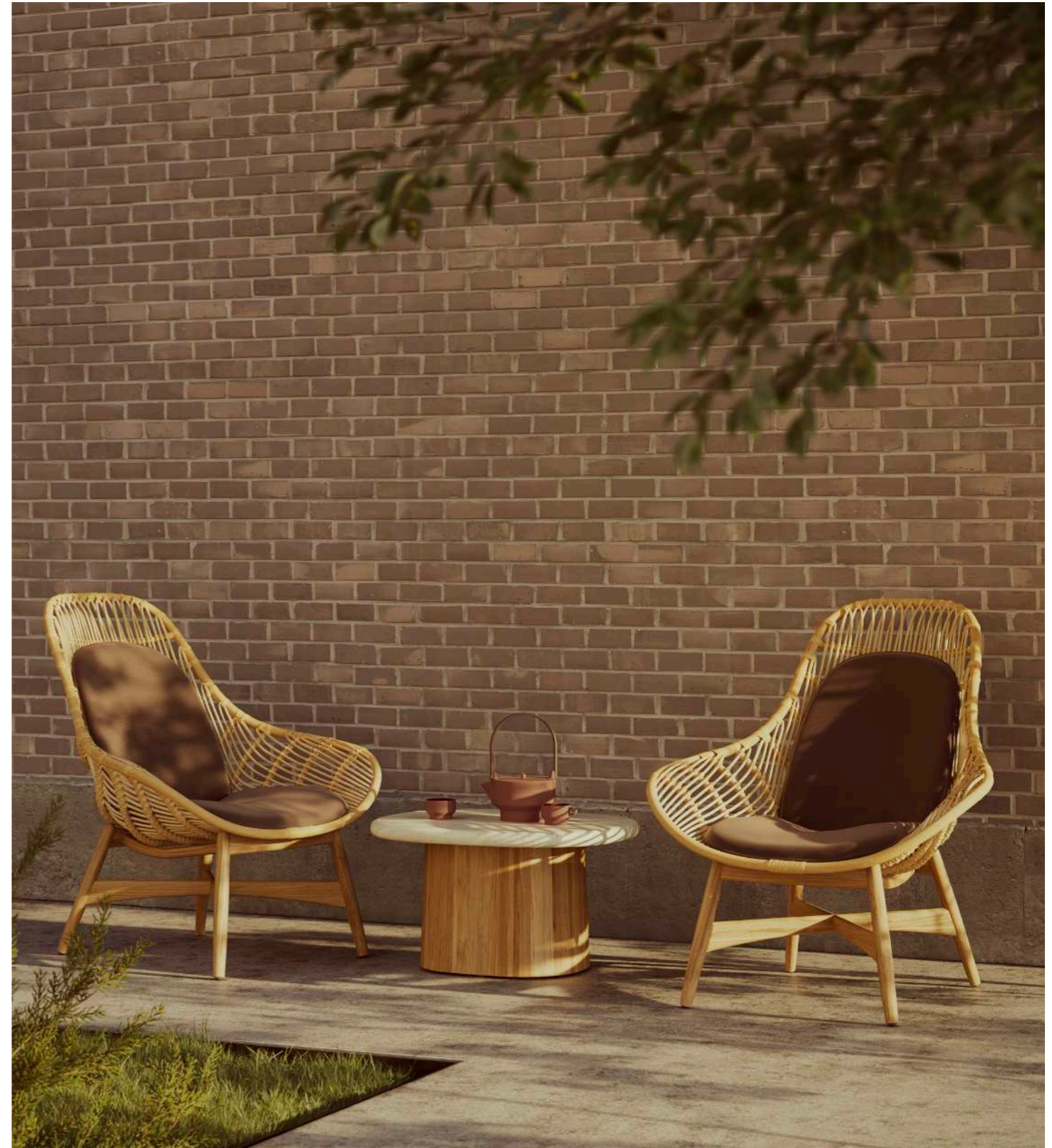
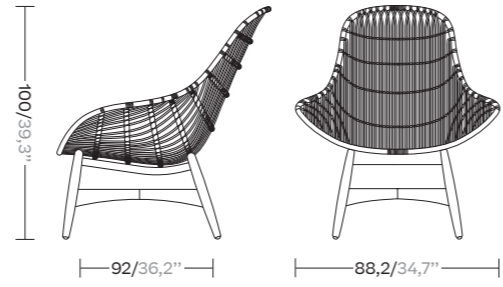



# Altar, by Miguel Milá

Miguel Milá designed this table in the mid-sixties as an altar for his wedding. It later became a table for everyday use, but was never produced. As if he were a master craftsman, Miguel Milá designed this piece based on the art of simplicity and efficiency. Its shape hides its complexity, but at the same time

reveals the wood's own character, giving it life and prominence. Its constructive logic makes it strong enough in terms of structure, but formally a beautiful piece. The beauty of logic and common sense understands neither time nor trend.



Dining table

KSA400200

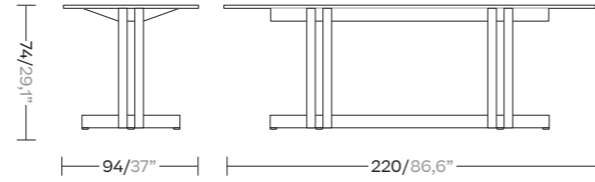

Dining table

KSA400100

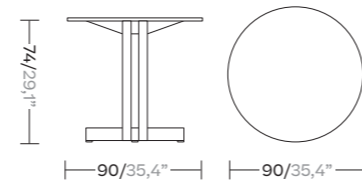



# Pad, by Kettal studio

Kettal has made deck chairs for decades, and always of the same excellent quality. This enables us to offer a product that garners all that experience: comfort, durability, stackability and so on. Pad is a sturdy, long-lasting deck chair system designed for relaxing in comfort. It is built to withstand continued

use. The sturdy seat guys and backrest can be easily changed. The ample seat surface and sandwich-style structure make it exceptionally comfortable. With a stretch guy attached to the aluminium frame and optional cushions that add extra comfort.





Deckchair

KSA700100

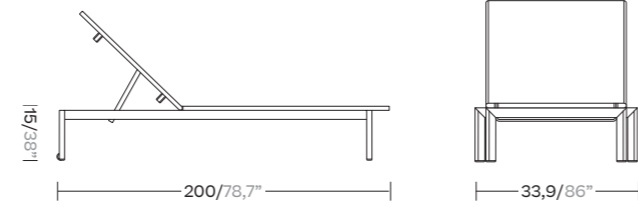





# Arc, by Kettal studio

The Arc collection features an enveloping backrest based on fundamental geometry: a constant radius arc. It shows restrained, elegant proportions. The light aluminium frame clearly expresses a desire to maintain armchair tradition. The backrest features simple yet sophisticated braided

strips, while the seat is padded with polyurethane foam covered in matching fabric and the fabric cushion has a removable cover.

The collection is used mostly in hotels, in lobbies and rooms, on cruise ships and also in domestic settings as light furniture in sofa and dining areas.



Dining armchair

KSA500100

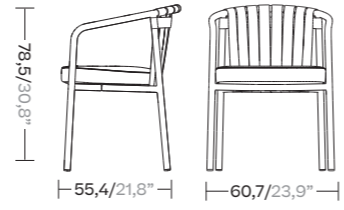

Club armchair

KSA500200

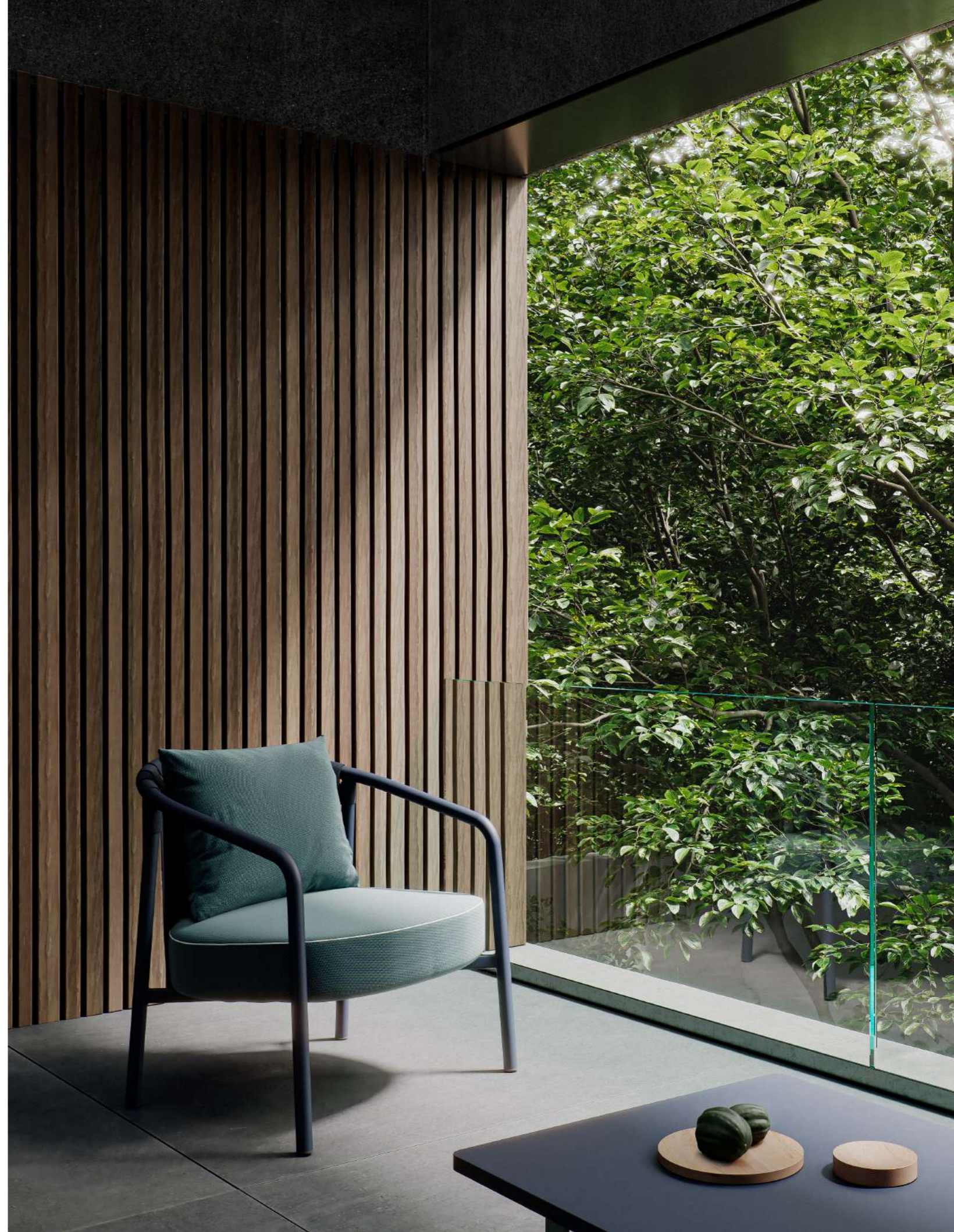
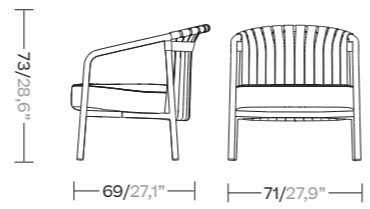



# Paladin, by Konstantin Grcic

Paladin is a wooden parasol for domestic and public use. Its canopy appears to be floating on top of an elegantly shaped mast. The design employs a mechanical principle which incorporates the tension of the canopy into its structural logic. With only the mast and four movable struts, the textile absorbs the tensile forces of the parasol when unfolded. The mast goes right through the center of the canopy,

leaving a central hole that is acting as an indirect skylight and allowing for air circulation. The wooden elements are made in natural teak with a reinforcing core in aluminium. The mechanical joints and fasteners in aluminium and stainless steel are designed to minimize the material input while offering maximum performance.





Paladin

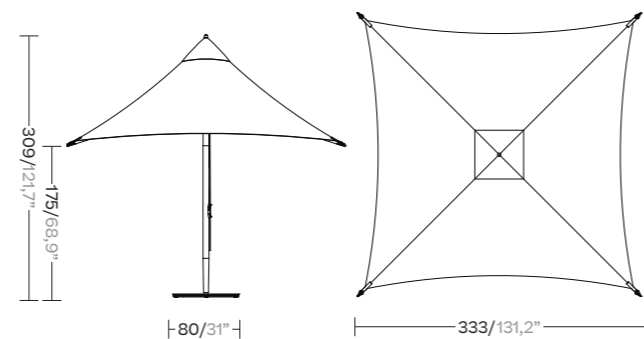

KSB100100

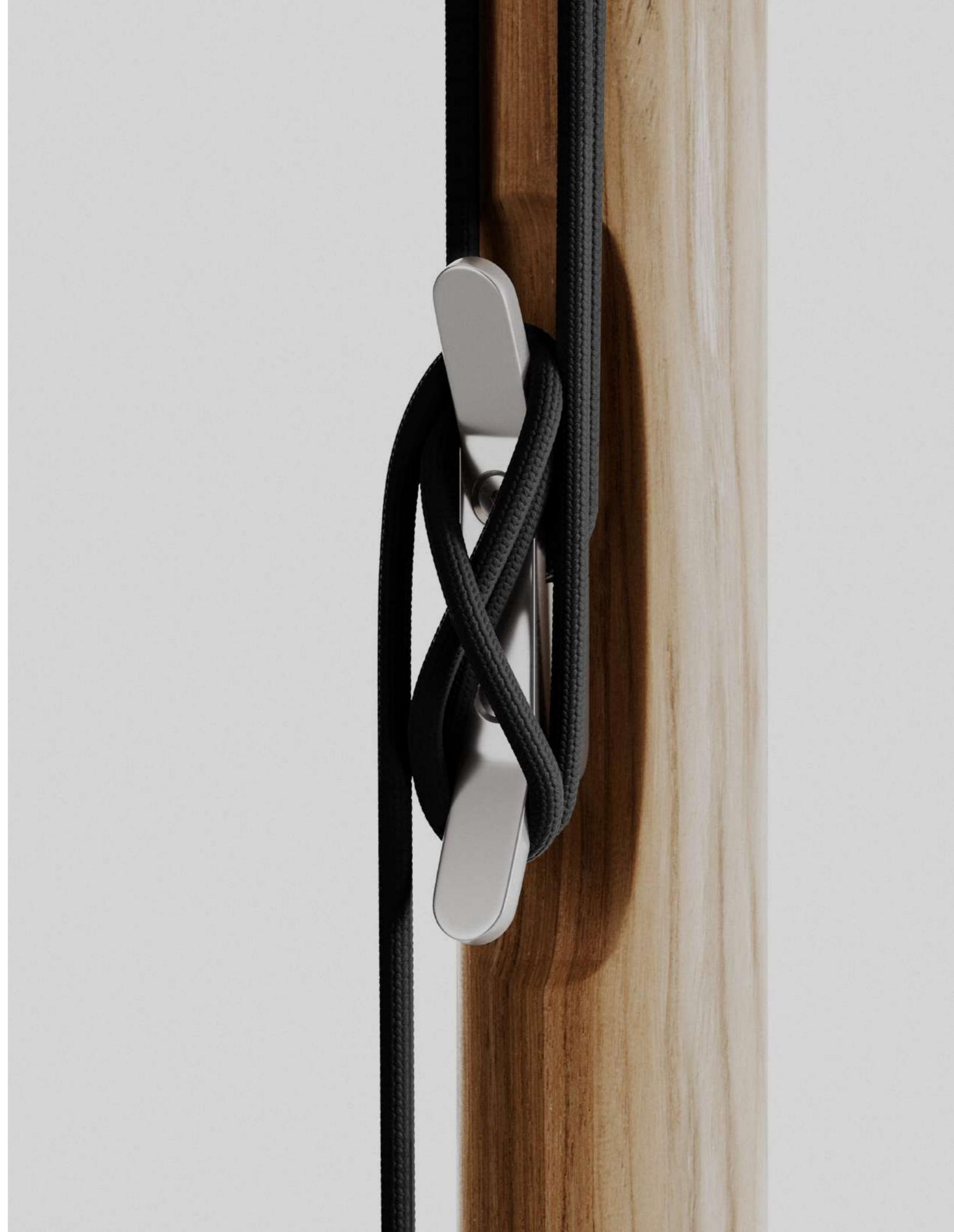



# Superfan by Michael Anastassiades

Superfan is a tri-blade fan whose geometry is simply defined through three angled blades, meeting at the rotating axis. All design decisions are made to maximise performance and improve efficiency: the angle of the blades, the lightness of the aluminium material and the selection of the motor for accurate speed control and quiet function.

The two fan versions operate with equal efficiency both with and without a pendant, offering flexibility of use for different ceiling heights.



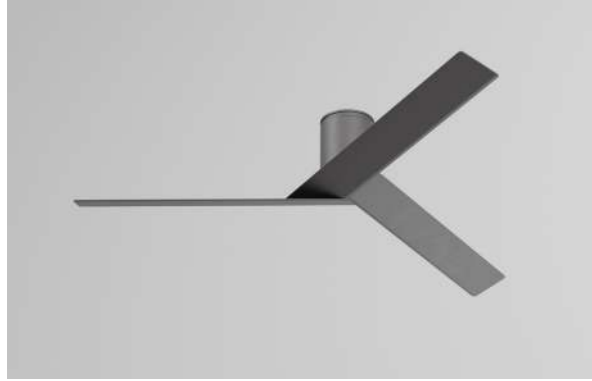

Ceiling fan

KSA900100

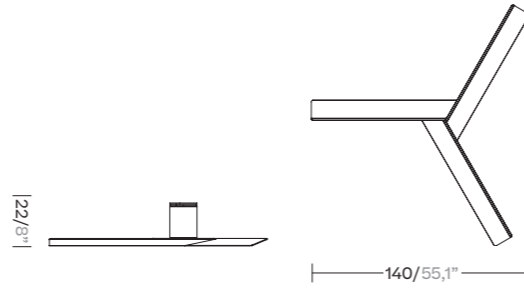

Ceiling fan downrod

KSA900200

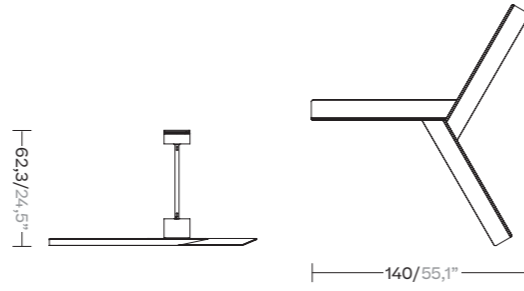



# Base Kitchen by Kettal Studio



This modular kitchen structure offers infinite solutions. An aluminium supporting frame can be teamed with a number of stoneware modules in various combinations whilst maintaining its authentic linear design. This design features clean, smooth surfaces, with no corners, for easy cleaning and maintenance.

It is available in two types of stoneware and two Iroko wood finishes for the doors. The modular aluminium structure comes in black only. Along with basic kitchen functions, it has a gas barbecue and can include several burners with a support for a wok. It can also include a bar.





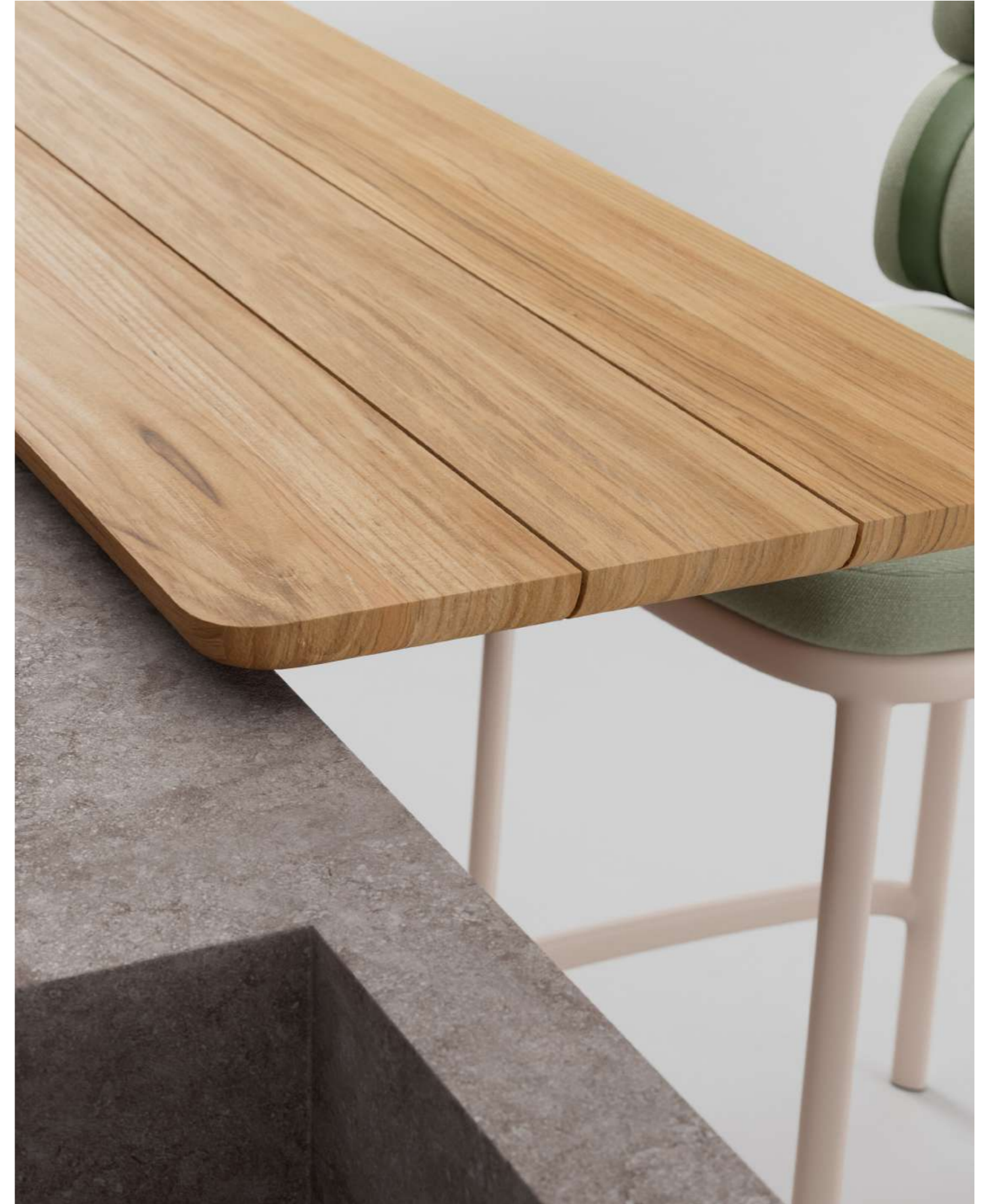



Cook

KSA602210 1 or 2 gas cooker

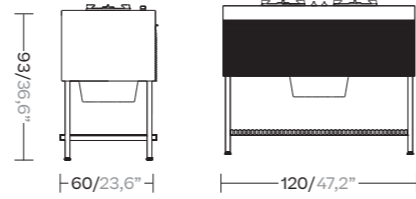

Barbaque

KSA602220

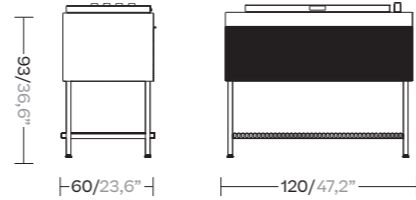

Sink top

KSA62200

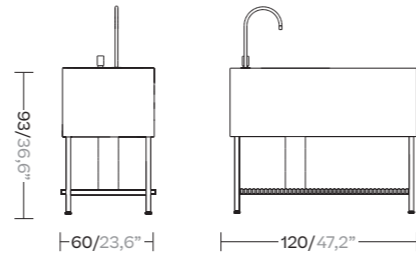

Work top

KSA602100

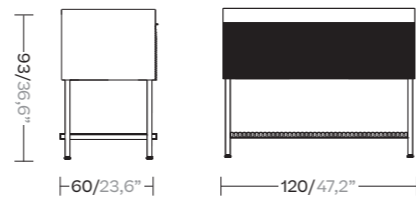

Fridge Module

KSA602230

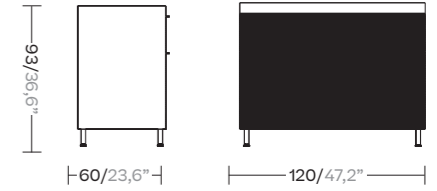

Kitchen bar

A6800BKT00

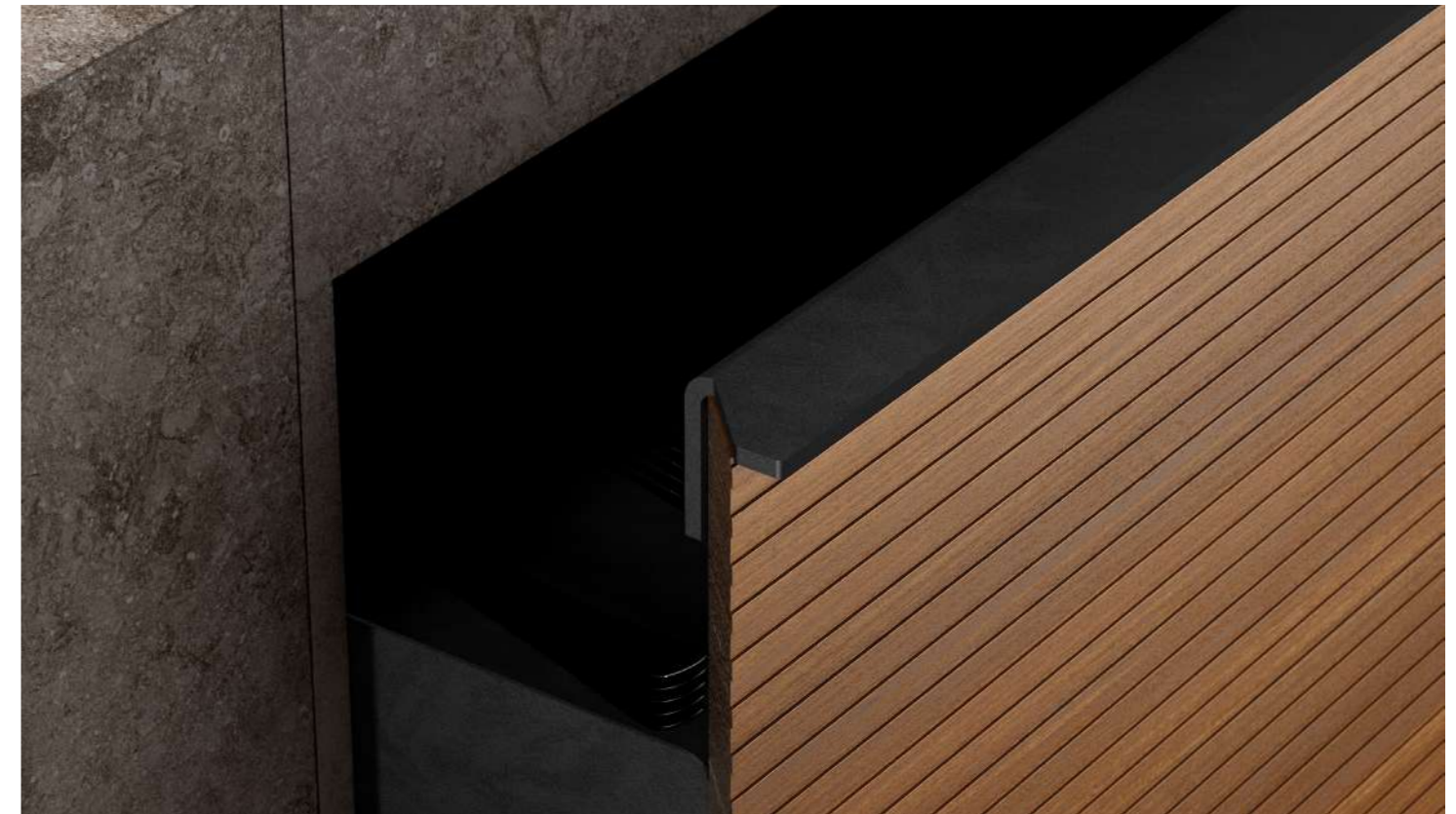
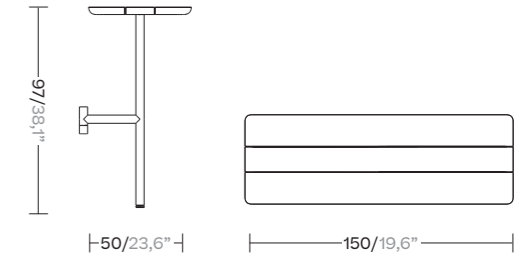



# Hydroponic Garden

Kettal and Tectum Garden present Hydroponic Garden, a hydroponic vegetable garden. Hydroponic Garden is based on edible renaturalisation. It is grown without soil in a light substrate to avoid excess weight. Watering is by drip, which reduces consumption and contains suitable water-soluble fertilisers; the nutrient-rich excess water is reused. The lighting, either artificial using LEDs or natural, is adapted to each crop. The materials used in the Hydroponic Garden are 75% recycled and 100% recyclable.

Hydroponic Garden was developed by an interdisciplinary team: environmentalists, agronomists, architects, designers, engineers, scientists... The aim of this creation is to ecodesign the spaces and offices of the future in order to address climate change, improve quality of life in cities, transform work environments to create a link with the natural environment by means of agri-productive areas, and foster a more sustainable future through the circular green economy.







# We would love to hear from you.

## Head office

Kettal Barcelona  
Aragón, 316  
08009 Barcelona, Spain  
T. (34) 93 487 90 90  
F. (34) 93 487 90 66



See all the finishes colors  
of the images here

## Showrooms

Miami Showroom  
147 Miracle Mile  
Coral Gables,  
Florida 33134, USA  
t. (1) 786 552 90 22  
miami.store@kettal.es

Paris Showroom  
80, Blvd Malesherbes  
75008 Paris, France  
t. (33) 1 43 59 51 40  
boutique.paris@kettal.es

London Showroom  
Contract & Workplace  
15-16 Dufferin St,  
London EC1Y 8UR, Reino Unido  
t. +44 7507 717891

Marbella Showroom  
Crtra. de Cádiz, Km.179  
(entre el Marbella Club  
y el Guadalpin)  
29600 Marbella, Spain  
t. (34) 95 277 89 89  
tienda.marbella@kettal.es

Chicago  
The Mart.  
222 Merchandise Mart Plaza,  
Suite 10-155  
Chicago, IL 60654 USA.  
T. 312.244.0527  
chicago.showroom@kettal.es

New York  
The D&D Annex:  
222 East 59th Street  
Suite 222-333  
New York, NY 10022, USA  
t. (1) 917-992-9419  
newyork.showroom@kettal.com

Kettal Barcelona  
Aragón, 316  
08009 Barcelona, Spain  
T. (34) 93 488 10 80  
tienda.bcn@kettal.es

London Showroom  
Residential  
567 Kings Road,  
London SW6 2 EB  
t. (44) 20 7371 5170  
sales@kettal.co.uk

## Press Kit



To download the Press Releases and  
high res images please register in the  
Press Area here