

GERVASONI™

**GRAY
NEXT
SILVER**



BRICK 99



BRICK 97



BRICK 96



SILVER 96



NEXT 121



NEXT 33



NEXT 123



NEXT 121

NEXT 33



SILVER 96

SILVER 95

MORE 07 L / 06 / 22 R

NEXT 148

NEXT 147

NEXT 999



NEXT 148

NEXT 147





SILVER 96

SILVER 95



SILVER 95

BRICK 98

BRICK 99

BRICK 97

SILVER 95

BRICK 96

GRAY 23

GRAY 33 AL

NEXT 25



NEXT 25

GRAY 33 AL



NEXT 121

GRAY 33 AL



SWEET 98



SILVER 95



NEXT 121



NEXT 36



NEXT 123

SWEET 98



SILVER 95



NEXT 123

NEXT 36





MORE 25 P

BOLLA 12

GRAY 61

MIK 12

NEXT 147

NEXT 148

BRICK 99

BRICK 97





NEXT 148

MORE 25



p. 6 / 7

- 1 MORE 07L, 06, 22R / DEUS Tritone – C (5350 Mare)
CUSHIONS:
 2 DEUS Tritone – C (5350 Mare)
 3 BIRDS Crow – C (6525 Grafite)
 4 POLY Inchiostro – B (6000 Denim)
 5 DEUS Bacco – C (8450 Rosa)



p. 12 / 13

- 1 NEXT 25 / MALTA 3 Notte – C (1050 Panna)

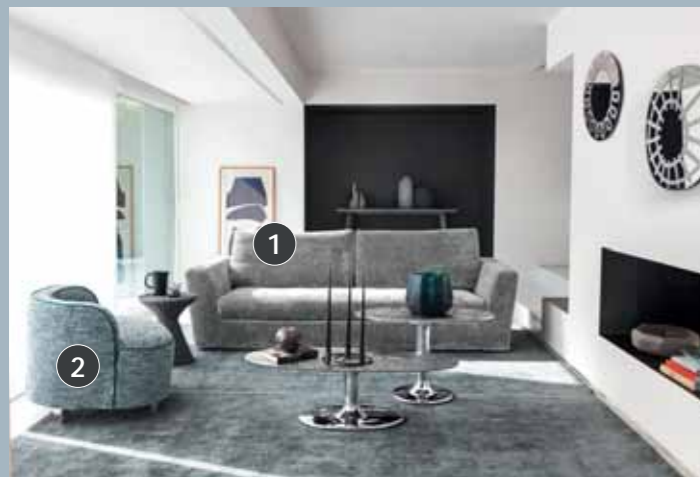

p. 22 / 23

- 1 MIK 12 / DEUS Atena – C (6375 Perla)
 2 MORE 25 P / ANIMALS Snake – C (4525 Spritz)



p. 26 / 27

- 1 MORE 25 / ATMOSFERA Tempesta – C (1050 Panna)

Gray 32 AL

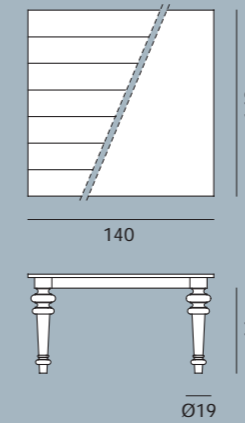

Tavolo quadrato con gambe in fusione di alluminio lucidato, piano fisso a doghe impiallacciate in noce o rovere, ardesia a spacco, marmo bianco Carrara o lamiera di ferro cerata. Finiture legno disponibili: noce Canaletto verniciato naturale; rovere sbiancato o rovere laccato bianco, grigio, avio, nero.

Square table with feet in cast polished aluminum, fixed veneered slat top made in walnut/ oak, rough-cut slate, Carrara white marble or waxed iron plate. Available wood finishes: natural lacquered American walnut; bleached oak; white, grey, air force blue, black lacquered oak.

Viereckiger Tisch, FüÙe aus Gussaluminium poliert., feste Leistenplatte aus Nussbaum / Eiche, aus gespaltenem Schiefer, aus weißem Carrara-Marmor, aus gewachsenem Stahl. Lieferbare HolzAusführungen: amerikanisches Nussbaum natur lasiert; Eiche gebleicht; Eiche weiß, grau, schieferblau, schwarz lackiert.

Table carrée en en fonte d'aluminium poli, plateau fixe plaqué à lattes de noyer / chêne, en ardoise naturelle sans ponçage, en marbre blanc de Carrare, en tôle de fer cirée. Finitions du bois disponibles: noyer américain verni naturel; chêne blanchi; chêne laqué blanc, gris, bleu ardoise, noir.

p. 12 / 13 / 15 / 16 / 17

Gray 33 AL

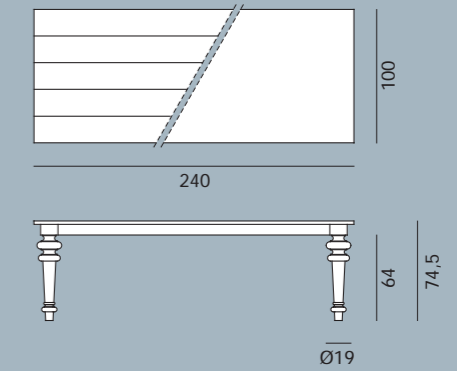

Tavolo rettangolare con gambe in fusione di alluminio lucidato, piano fisso a doghe impiallacciate in noce o rovere, ardesia a spacco, marmo bianco Carrara o lamiera di ferro cerata. Finiture legno disponibili: noce Canaletto verniciato naturale; rovere sbiancato o rovere laccato bianco, grigio, avio, nero.

Rectangular table with feet in cast polished aluminum, fixed veneered slat top made in walnut/ oak, rough-cut slate, Carrara white marble, or waxed iron plate. Available wood finishes: natural lacquered American walnut; bleached oak; white, grey, air force blue, black lacquered oak.

Rechteckiger Tisch, FüÙe aus Gussaluminium poliert., feste Leistenplatte aus Nussbaum / Eiche, aus gespaltenem Schiefer, aus weißem Carrara-Marmor, aus gewachsenem Stahl. Lieferbare HolzAusführungen: amerikanisches Nussbaum natur lasiert; Eiche gebleicht; Eiche weiß, grau, schieferblau, schwarz lackiert.

Table rectangulaire, pieds en en fonte d'aluminium poli, plateau fixe plaqué à lattes de noyer / chêne, en ardoise naturelle sans ponçage, en marbre blanc de Carrare, en tôle de fer cirée. Finitions du bois disponibles: noyer américain verni naturel; chêne blanchi; chêne laqué blanc, gris, bleu ardoise, noir.

Gray 34 AL

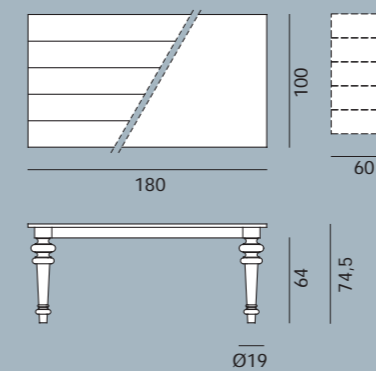

Tavolo rettangolare con gambe in fusione di alluminio lucidato, piano fisso a doghe impiallacciate in noce o rovere, ardesia a spacco, marmo bianco Carrara o lamiera di ferro cerata. Finiture legno disponibili: noce Canaletto verniciato naturale; rovere sbiancato o rovere laccato bianco, grigio, avio, nero. Disponibile anche con piano allungabile (+ 60 cm) a doghe di noce o rovere.

Rectangular table with feet in cast polished aluminum, fixed veneered slat top made in walnut/ oak, rough-cut slate, Carrara white marble, or waxed iron plate. Available wood finishes: natural lacquered American walnut; bleached oak; white, grey, air force blue, black lacquered oak. Available also with extendable slat top in walnut/ oak (+ 60 cm).

Rechteckiger Tisch, FüÙe aus Gussaluminium poliert., feste Leistenplatte aus Nussbaum / Eiche, aus gespaltenem Schiefer, aus weißem Carrara-Marmor, aus gewachsenem Stahl. Lieferbare HolzAusführungen: amerikanisches Nussbaum natur lasiert; Eiche gebleicht; Eiche weiß, grau, schieferblau, schwarz lackiert. Lieferbar auch mit ausziehbarer Leistenplatte (+ 60 cm) aus Nussbaum / Eiche.

Table rectangulaire, pieds en en fonte d'aluminium poli, plateau fixe plaqué à lattes de noyer / chêne, en ardoise naturelle sans ponçage, en marbre blanc de Carrare, en tôle de fer cirée. Finitions du bois disponibles: noyer américain verni naturel; chêne blanchi; chêne laqué blanc, gris, bleu ardoise, noir. Disponible avec plateau à lattes avec rallonge (+60 cm) en noyer / chêne.

Gray 35 AL

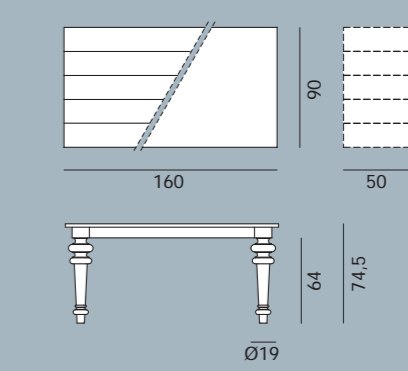

Tavolo rettangolare con gambe in fusione di alluminio lucidato, piano fisso a doghe impiallacciate in noce o rovere, ardesia a spacco, marmo bianco Carrara o lamiera di ferro cerata. Finiture legno disponibili: noce Canaletto verniciato naturale; rovere sbiancato o rovere laccato bianco, grigio, avio, nero. Disponibile anche con piano allungabile (+ 50 cm) a doghe di noce o rovere.

Rectangular table with feet in cast polished aluminum, fixed veneered slat top made in walnut/ oak, rough-cut slate, Carrara white marble, or waxed iron plate. Available wood finishes: natural lacquered American walnut; bleached oak; white, grey, air force blue, black lacquered oak. Available also with extendable slat top in walnut/ oak (+ 50 cm).

Rechteckiger Tisch, FüÙe aus Gussaluminium poliert., feste Leistenplatte aus Nussbaum / Eiche, aus gespaltenem Schiefer, aus weißem Carrara-Marmor, aus gewachsenem Stahl. Lieferbare HolzAusführungen: amerikanisches Nussbaum natur lasiert; Eiche gebleicht; Eiche weiß, grau, schieferblau, schwarz lackiert. Lieferbar auch mit ausziehbarer Leistenplatte (+ 50 cm) aus Nussbaum / Eiche.

Table rectangulaire, pieds en en fonte d'aluminium poli, plateau fixe plaqué à lattes de noyer / chêne, en ardoise naturelle sans ponçage, en marbre blanc de Carrare, en tôle de fer cirée. Finitions du bois disponibles: noyer américain verni naturel; chêne blanchi; chêne laqué blanc, gris, bleu ardoise, noir. Disponible avec plateau à lattes avec rallonge (+50 cm) en noyer / chêne.

Next 33

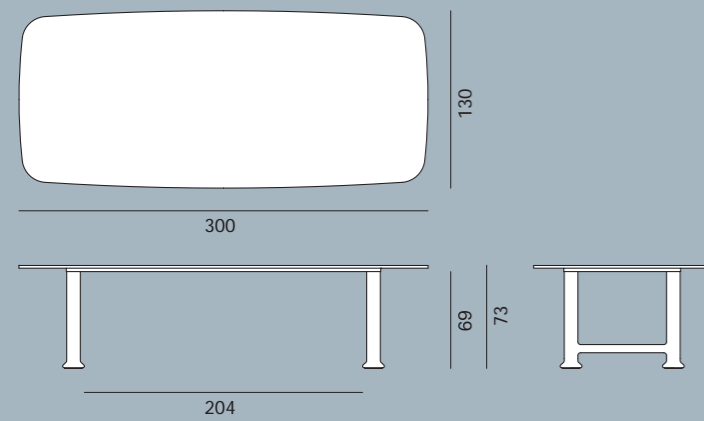

Tavolo rettangolare con gambe in fusione di alluminio lucidato e piano in marmo bianco Carrara.
 Rectangular table with feet in cast polished aluminum and white Carrara marble top.
 Rechteckiger Tisch, FüÙe aus Gussaluminium poliert, Platte aus weiÙem Carrara-Marmor.
 Table rectangulaire, pieds en fonte d'aluminium poli, plateau en marbre blanc de Carrare.

Next 34

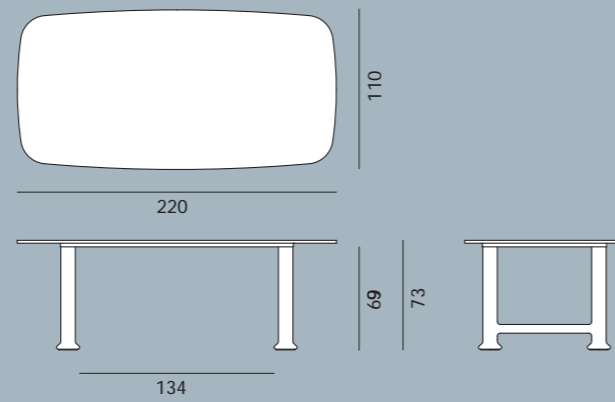

Tavolo rettangolare con gambe in fusione di alluminio lucidato e piano in marmo bianco Carrara.
 Rectangular table with feet in cast polished aluminum and white Carrara marble top.
 Rechteckiger Tisch, FüÙe aus Gussaluminium poliert, Platte aus weiÙem Carrara-Marmor.
 Table rectangulaire, pieds en fonte d'aluminium poli, plateau en marbre blanc de Carrare.

Next 121

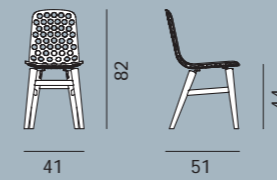

Sedia, scocca in fusione di alluminio lucidato decorato con macrofori, gambe in noce o rovere. Finiture legno disponibili: noce Canaletto verniciato naturale; rovere sbiancato o rovere laccato bianco, grigio, avio, nero.
 Shell chair in cast polished aluminum decorated with macropores, wooden legs in walnut / oak. Available wood finishes: natural lacquered American walnut; bleached oak; white, grey, air force blue, black lacquered oak.
 Stuhl, Sitzschale aus Gussaluminium poliert, mit Lochdekor, Beine aus Nussbaum / Eiche. Lieferbare Holzausführungen: amerikanisches Nussbaum natur lasiert; Eiche gebleicht; Eiche weiß, grau, schieferblau, schwarz lackiert.
 Chaise, coque en fonte d'aluminium poli avec déco à grands trous, pieds en noyer / chêne. Finitions du bois disponibles: noyer américain verni naturel; chêne blanchi; chêne laqué blanc, gris, bleu ardoise, noir.

Next 123

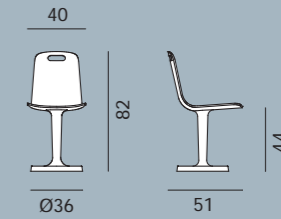

Sedia, scocca e gamba centrale in fusione di alluminio lucidato. Disponibile con base girevole.
 Shell chair with central base in cast polished aluminum. Available with swivel base.
 Stuhl, Sitzschale und Unterbau aus Gussaluminium poliert. Lieferbar mit Drehfunktion.
 Chaise avec coque et piètement en fonte d'aluminium poli. Disponible avec piètement pivotant.

Next 25

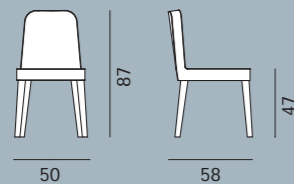

Sedia, struttura in noce o faggio, seduta e schienale imbottiti in poliuretano espanso. Rivestimento sfoderabile con cucitura taglia e cuci e fondo libero. Finiture legno disponibili: noce Canaletto verniciato naturale o faggio laccato bianco, grigio, avio, nero.
 Side chair in walnut or beechwood, seat and back upholstered with polyurethane foam, removable cover with stitching and free fastening. Available wood finishes: natural lacquered American walnut; white, grey, air force blue, black lacquered beechwood.

Stuhl aus Nussbaum oder Buche, gepolsterte Sitz und Rückenlehne, abziehbar mit Overlock-Nähten (lose Ausführung). Lieferbare Holzausführungen: amerikanisches Nussbaum natur lasiert oder Buche weiß, grau, schieferblau, schwarz lackiert.

Chaise en noyer ou hêtre, assise et dossier rembourrés en mousse polyuréthane, housse flottante amovible avec surpiqûres. Finitions du bois disponibles: noyer américain vernis naturel ou hêtre laqué blanc, gris, bleu ardoise, noir.

Next 32/36

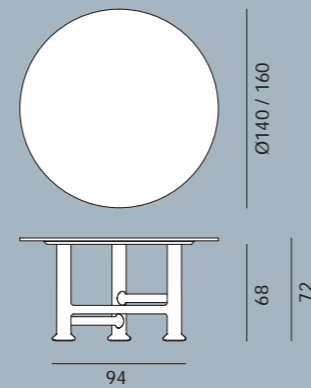

Tavolo rotondo con gambe in fusione di alluminio lucidato e piano in marmo bianco Carrara.
 Round table with feet in cast polished aluminum and white Carrara marble top.
 Runder Tisch, FüÙe aus Gussaluminium poliert, Platte aus weiÙem Carrara-Marmor.
 Table ronde, pieds en fonte d'aluminium poli, plateau en marbre blanc de Carrare.

Next 147/148

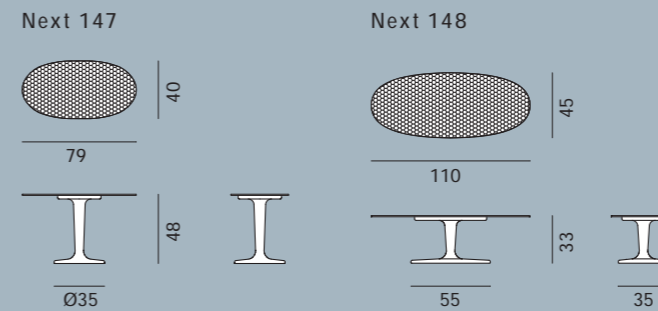

Tavolino in fusione di alluminio lucidato. Piano decorato effetto martellato.
 Coffee table in cast polished aluminium. Hammered top.
 Couchtisch aus Gussaluminium poliert. Platte gehämmert.
 Table basse en fonte d'aluminium poli. Plateau en aluminium martelé.

Silver 95/96

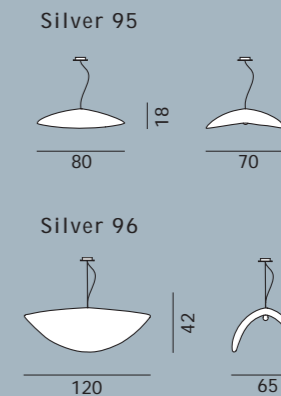

Lampada a sospensione in ottone finitura nichelata martellato. Potenza max. applicabile 18W, 220 Volt, attacco E 27, lampadina non fornita (lunghezza cavo elettrico 250 cm; lunghezza cavo in acciaio 200 cm).
 Suspension lamp in hammered nickel-plated brass. Max. power 18 W, 220 Volt, bulb holder E 27, bulb not included (electrical cable length 250 cm; steel cable length 200 cm).
 Deckenleuchte aus vernickeltem Messing, gehämmert. Maximale Stärke 18 W, 220 Volt, Lampenfassung E 27, Birne nicht mitgeliefert (Elektrokabellänge 250 cm; Stahlkabellänge 200 cm).
 Suspension en laiton nickelé martelé. Puissance max. 18 W, 220 Volt, douille de lampe E 27, ampoule non fournie (longueur du câble électrique 250 cm; longueur du câble d'acier 200 cm).

GERVASONI™

Gervasoni spa.
Viale del Lavoro, 88
33050 Pavia di Udine, Italia
ph +39 0432 656611
fax +39 0432 656612
info@gervasoni1882.com
www.gervasoni1882.com



ITALIAN DESIGN BRANDS™

Gervasoni fa parte del gruppo
Italian Design Brands
Gervasoni is part of Italian
Design Brands Group

Gervasoni spa è dotata di un Sistema di Qualità Certificato UNI EN ISO 9001, di un Sistema per la gestione della Sicurezza e della Salute dei lavoratori Certificato OHSAS 18001 e di un Sistema di Gestione Ambientale Certificato UNI EN ISO 14001.
Gervasoni spa is certified to: UNI EN ISO 9001 Company Quality System Certification, OHSAS 18001 Certification for Health and Safety Management Systems and UNI EN ISO 14001 Environmental Management Systems Certification.



CREDITS:

creative direction **PAOLA NAVONE**
product design **OTTO / DOMENICO DIEGO,**
MARCO OLGIATI, TATIANA KHNYZHOVA
style coordinator **OTTO / CRISTINA PETTENUZZO**
photo **ALESSANDRO PADERNI / EYE STUDIO**
styling **BEPPE MANGIA**
graphic **GENNY CANTON STUDIO**
separations **LUCE SRL**

THANKS TO:

VATTOLO, UD



CATNEXT19

GERVASONI™