



Il giardino di legno

Fantasie en plein air





Il giardino di legno

Fantasia
en plein air

NANT03B6
NANT0413
TILT2501



IL GIARDINO DI LEGNO

Il Giardino di Legno progetta e produce con passione nel settore dell'arredamento, con particolare attenzione alla lavorazione del legno ed ai materiali per l'outdoor.

Il carisma silenzioso e le eclettiche competenze professionali ne caratterizzano non solo la produzione ma anche il supporto offerto al cliente e al progettista. La combinazione armonica di molteplici professionalità scaturisce in un gruppo di lavoro che affronta ogni progetto come una sfida, ogni richiesta del cliente come una mission, ogni ricerca di un nuovo materiale come uno stimolo per l'approfondimento delle proprie esperienze e conoscenze.

Una raccolta di oggetti d'arredo in cui differenti essenze, materiali e cromie si mescolano e si miscelano nel processo creativo per offrire nuove soluzioni ed essere fonte d'ispirazione per l'arredamento del vostro Giardino di Legno.

Il Giardino di Legno designs and produces furniture with passion, focusing in particular on woodwork and outdoor materials.

The quiet charisma and the versatile professional skills characterize not only our production but also the support offered to all customers and designers. Our many different abilities combine seamlessly to give birth to great teamwork: we consider every project as a challenge, every request as a mission, every search for a new material as a way to boost and broaden our knowledge and experience.

In our furniture line, different essences, materials and colours are mixed and blended in the creative process so as to offer new solutions and become a source of inspiration when decorating your garden.

CORD02A3
CORD03B2
CORD08C1
PILW5050
RADIO4E1
SRI00234
TILT2501



PALE0889
PILW6060
PILW6030
SRTS02B2
SRTS02B3
SRTS04H8
SRTS02B4
TILT2501



SRI00210
SRI00226
SRI00227
SRI00228
SRTS03B5
SRTS04I2
TILT2501



SRI00270
SRTS04H9
SRTS04I1
SRTS0577
SRTS0578
SUAR0407
TILT2501



CHAR02A8
CHAR03B4
SRI00270
SRI00271
SRI00228
SRI00229
SRTS0411
SUAR0407
TILT2501



CHAR03B3
CHAR0571
MACR08C4
SRIO0233
SRIO0285
TILT2501





ANTI08A6
ANTI08A7
TILT2501

CHAR03B4
SRI00272
SRI00273
SRI00274
TILT2501



CHAR02A8
MACR0574
SRI00226
SRI00227
SRI00233
SRI00285
SRI00288
TILT2501

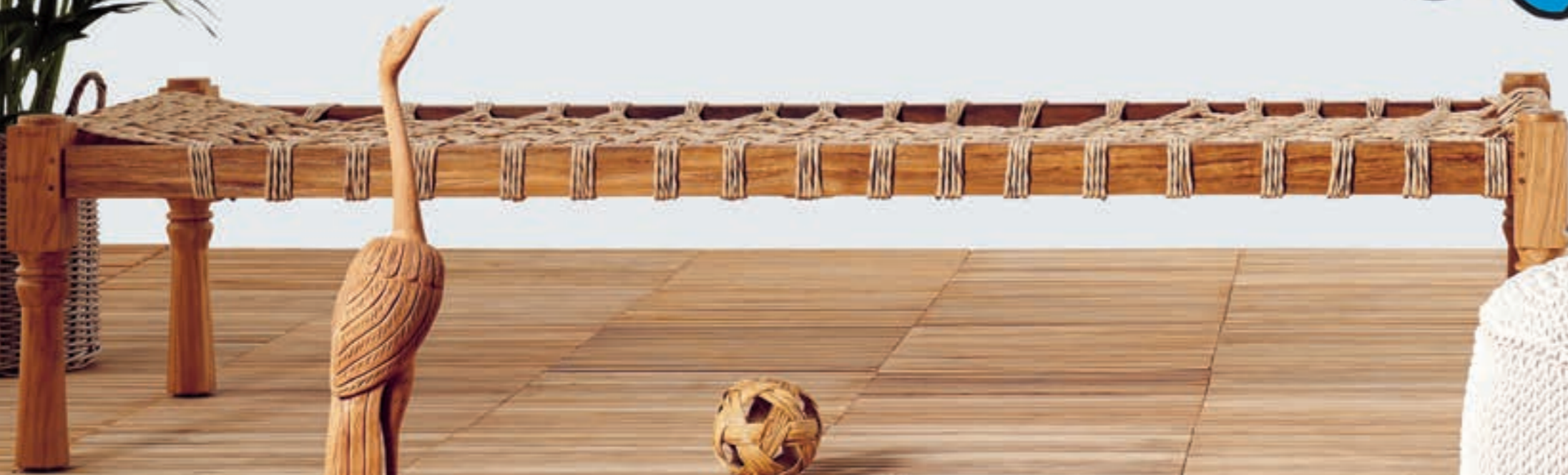

JENG04G2
JENG04G5
MACR08C3
SRI00209
SRI00300
TILT2501
VENE0507
VENE0854
ZOCM2500
ZPIS0322



JENG04G3 PILW4030
JENG04G4 SRI00272
MACR0573 SRI00247
MACR0574 TILT2501
MACR08C5



ACCP0824
ACCS0832
BIST0709
KARE03A5
SRI00272
SRI00285
TILT2501

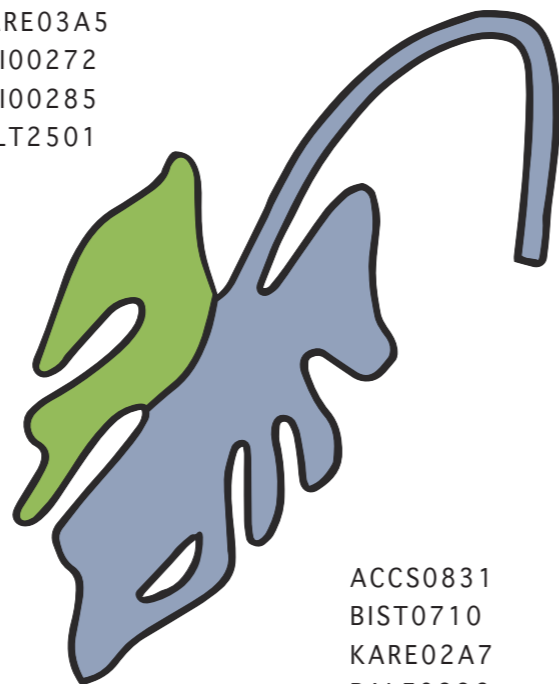

ACCS0831
BIST0710
KARE02A7
PALE0886
PALE08A3
SRI00285
TILT2501



PNSL02A9
PNSL02B1
PNSL04H7
TILT2501



PNSL04H3
PNSL0575
PNSL08C6
TILT2501



PNSL04H6
PNSL05H5
PNSL0576
TILT201





FMGL03B2
FMGL04H2
FMGL0570
PALE08A5
SRI00250
TILT2501

FMGL0570



ANTI02A6

ANTI0390
ANTI04E6





ANTI04E5
ANTI08A6



ANTI02A5



ANTI08A7
ANTI04E5

TOUT0561
TOUT0562





CODE0487
KROS03A6
KROS03A7



CODE0487
KROS03A5





GIPS0461
KROS03A8

CLAS0218
PALE0899
SRI00247
SRI00281
VENE0346
VENE0389
VENE0454
WALL08B1





VENE0389
VENE0454
PALE0899
SRI00246

SRI00268
SRI00302
SRI00303
VENE0548
ZOCW2500
ZPIS0322



SAVA0467
VENE03B1



PALE0885
PALE0899
PALE0895
PALE0889
PALE0897
PALE0893
PALE0883
PALE08A2
PALE0886
PALE08A2
PALE0883
PALE0897
PALE0889
PALE08A4
PALE0891
PALE0887
PALE0895





WALL04E8
WALL0396
SERE03A2
SRI00291



WALL04E8
WALL0396
SERE03A2
SRI00291



WALL04E8
WALL0397
SERE0398
SERE03A1
PALE08A2
SRI00291



WALL0296
ANTI04E5
SRI00265



KROS03A5
RMIX041A
PALE0893

KARE03A5
EMIL0459



ALIC0395
ALIC0476
TARA0291

ALIC04D6
ALIC0564
PALE08A4



CAPR04D4
CAPR0394
CAPR08B9
CAPR04D5
RMIX0563
SUAR04D7



CAPR0293
CAPR0294
CAPR04F4
CAPR04F5
SR100294



RADI0497
RMIX04E2
SERE0565
SERE0566
SRI00288



RMIX04G6
SERE02A1
SERE0299
SR100212
TARA02A2
TARA0392
VENE04E7





PALE0883
PALE0885
PALE0889
SERE0297

PALE0897
SERE0298
SRI00295
SUAR04D8
TETI04F8
TETI04G1





DESI0292
PALE0885
PHOE04F3



DESI0292
DESI04F7
PALE08A4
SRI00232



SUAR08B3
SUAR0411

DESI08B8
SRI00214
SRI00233





ANTI08B5
ANTI04E4
PALE0887
TOUT0561
TOUT0562

ACCT0810
PALE08A2
SRI00233

SUAR04D7
TILT2501
WAIK0569



BERB0712
PALE08A1
SRI00273
SUAR04G9
TILT2501





ACCS0834
EMIL4322
PALE0887
SRI00229
SRI00288
STRA0711
SUAR04G8
TILT2501

RING0567
RING0568
TILT2501
WALL08A8



The background is a vibrant, tropical-themed collage. It features various elements: a large green monstera leaf with a brown stem, a colorful parrot with yellow, orange, and green feathers, a bright yellow sun with rays, a pink and orange hibiscus flower, a large light blue leaf, and several other smaller leaves in shades of green, blue, and brown. The overall style is flat and colorful.

TECHNICAL DATA

RIEPILOGO TECNICO

ALICE

ADDENDUM full collection: CATALOGO GENERALE

Realizzata in rattan naturale intrecciato a mano e finito con finitura pigmentata natural semi-lucida e dettagli in nero. Tavolini con piano intrecciato in vimini e sovra-piano in vetro. La linea comprende i tavolini bassi rotondi, dalla base perforata, e la poltrona rotonda ad alcova nello stile delicato ed elegante della linea Alice: un piccolo rifugio per rilassarsi in spazi outdoor come giardini, terrazze o piscine.

Made of hand-woven natural rattan with semi-glossy natural color finish and black details. Occasional and low tables with woven wicker and glass top. The line includes low round tables, with perforated base, and a round alcove armchair in the delicate and elegant style of the Alice collection

ALIC0564



ALIC0564

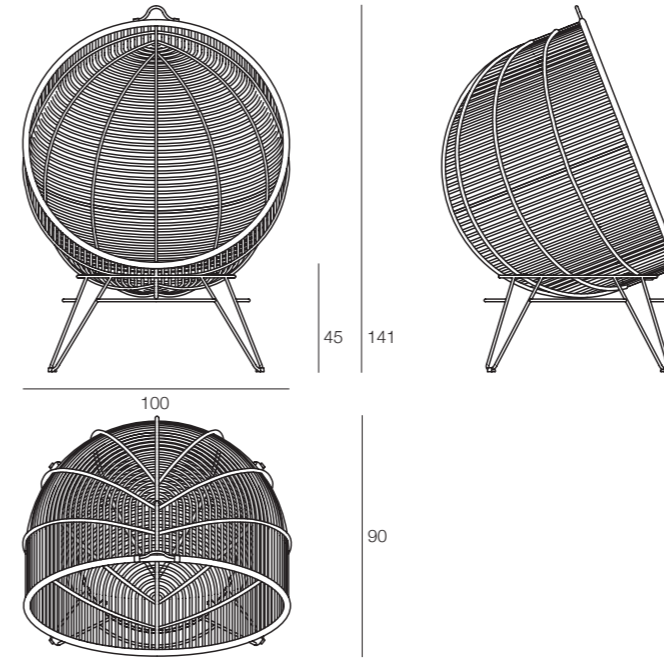

ALIC04D6



ALIC0476



ALIC04D6

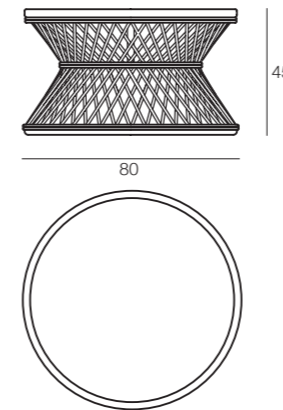

ALIC0476

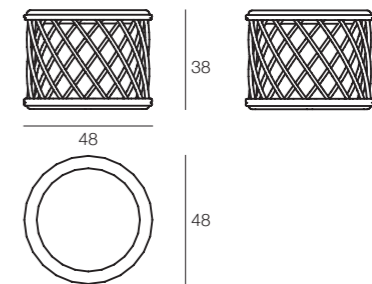

ALIC0395



ALIC0395

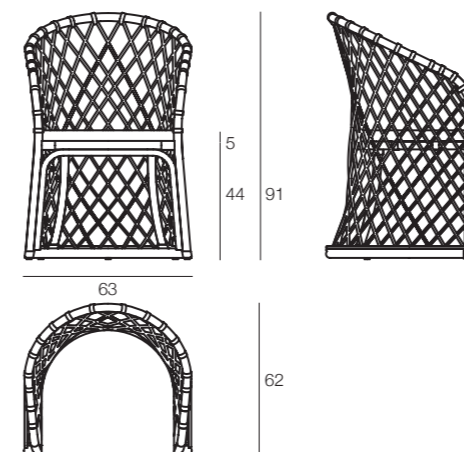

ANTIPODI

design by STUDIO SALARIS

La collezione Antipodi deve il suo nome all'accostamento di opposti che, uniti, creano un insieme unico e armonico. E' una collezione outdoor&indoor con una forte connotazione grafica. Ogni pezzo è progettato per sottrazione, riducendo al minimo il numero degli elementi del loro archetipo. Realizzata in finitura a polveri nera opaca ruvida e corda Talpa 5 mm tonda nella versione standard, è disponibile in altri colori e finiture.

The Antipodi collection owes its name to the combination of opposites that, united, create a unique and harmonious whole. It's an outdoor&indoor collection with a strong graphic connotation. Each piece is designed by subtraction, minimizing the number of elements of their archetype. Made with black doff powder coated metal and cord gray colour 5 mm in standard version, is available in other finishing and colours.

ANTI02A4_DBGC



ANTI02A5



ANTI02A6



ANTI02A4

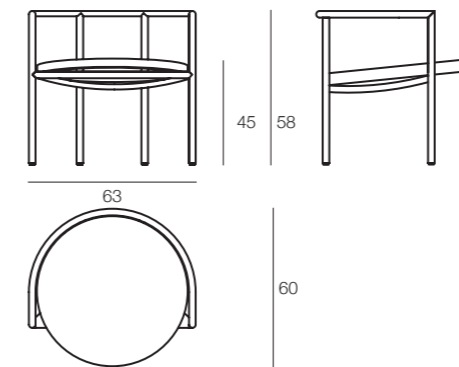

ANTI02A5

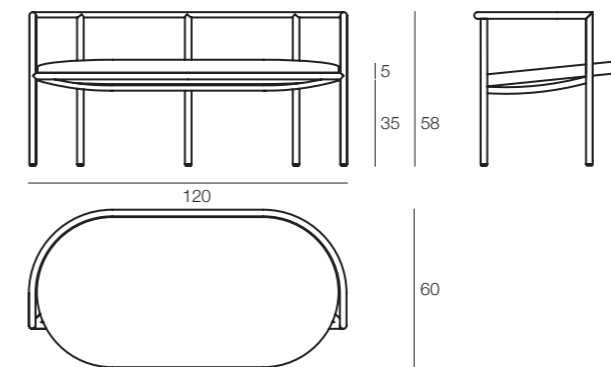

ANTI02A6

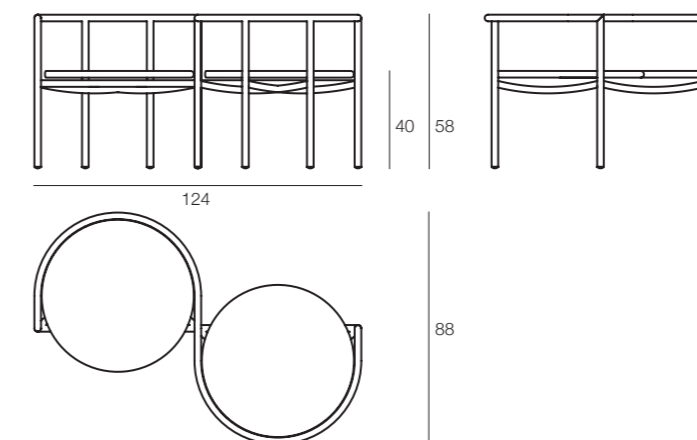

ANTI0390



ANTI0390

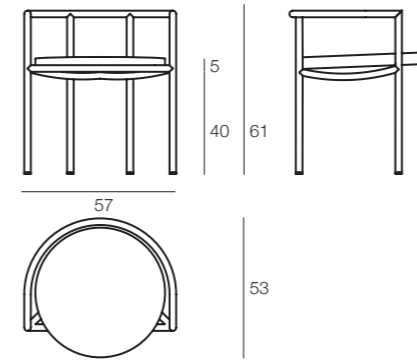

ANTI04E5



ANTI04E3



ANTI04E5

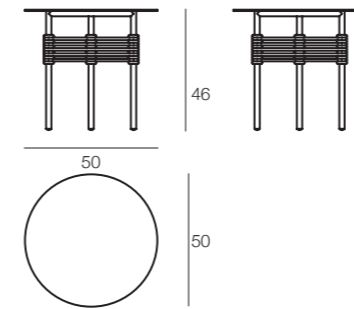

ANTI04E3

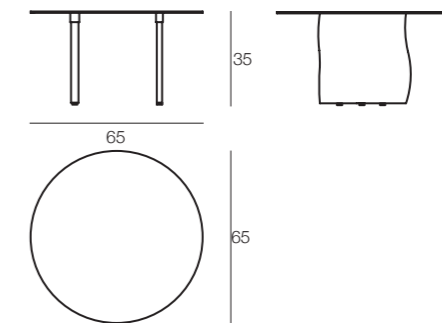

ANTI04E4



ANTI04E4

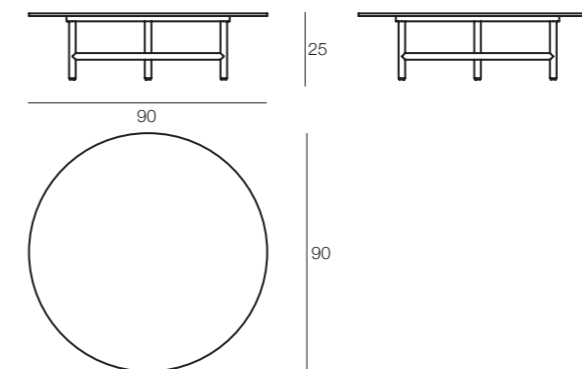

ANTI04E6



ANTI04E6

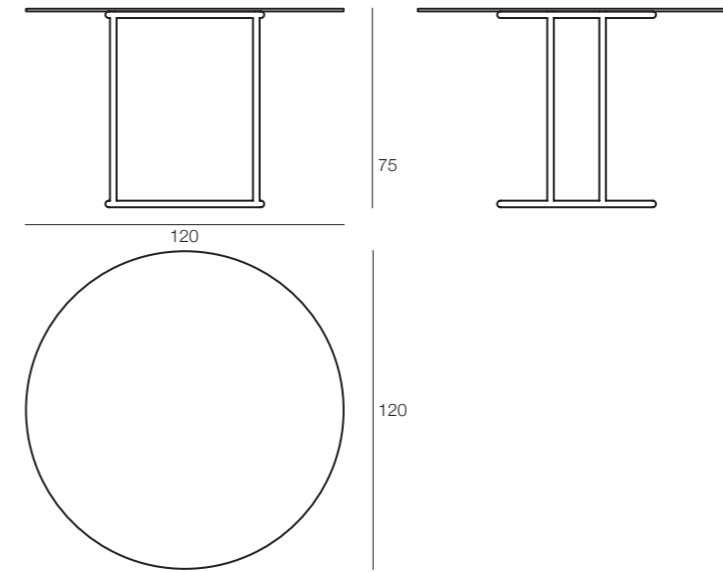

ANTI08A6



ANTI08A7



ANTI08A6

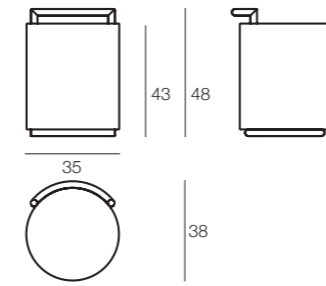

ANTI08A7

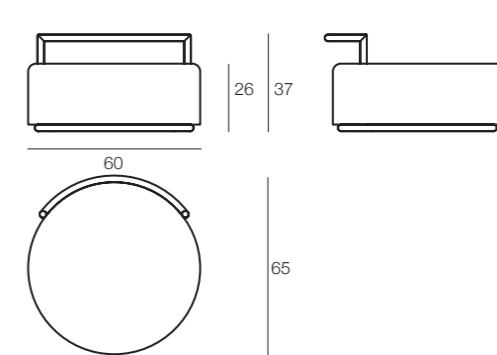

ANTI08B5



ANTI08B6



ANTI08B5

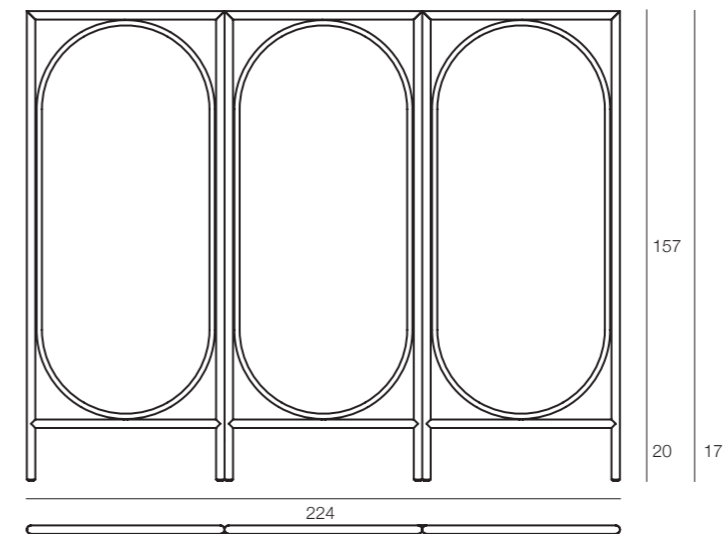

ANTI08B6

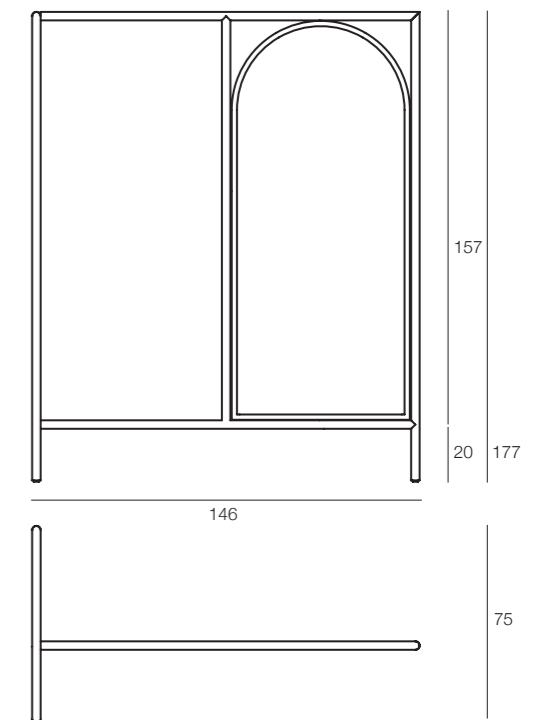

BISTROT

design by CRS SILAT

Bistrot è una collezione di tavolini con una base in metallo con finitura a polveri nera opaca: una linea che unisce la modernità del materiale con un design semplice ed estremamente elegante, per un outdoor contemporaneo. Pensata per il contract è anche adatta a terrazze cittadine o a giardini con uno stile senza tempo.

Bistrot is a collection of coffee tables with black doff powder coated metal base: a line that combines the modernity of the material with a simple and extremely elegant design, for a contemporary outdoor. Designed for contract, it is also suitable for city terraces or gardens with a timeless style.

BIST0709+ACCS0832



BIST0710+ACCS0831



BIST0709+ACCS0832

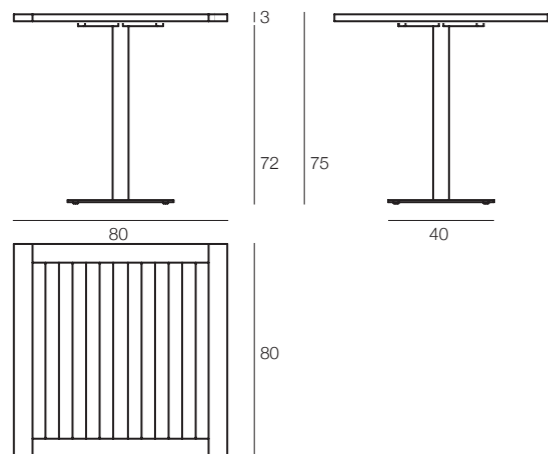

BIST0710+ACCS0831

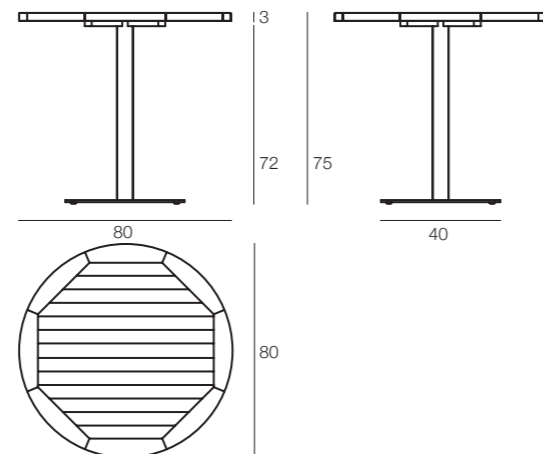

BERBEDA

ADDENDUM full collection: CATALOGO GENERALE

Gli abbinamenti curati, le finiture eleganti, i colori accesi e le sfumature classiche esaltano questa collezione dalle linee semplici ma ricercate. La struttura della base è disponibile nella finitura a polveri nera opaca ruvida o acciaio, il piano è proposto in Teak finito con levigatura fine naturale.

The well-finished combinations, elegant finishes, bright colors and classic shades intensify this collection with simple but refined lines. The table base is available with powder coated black matte or stainless steel with satin finish. Top in Fine Sanded Teak wood.

BERB5408_FSDB



BERB5408_FS



BERB5408

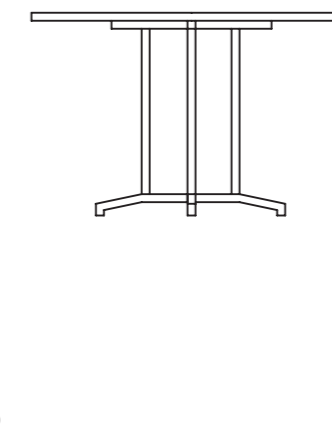
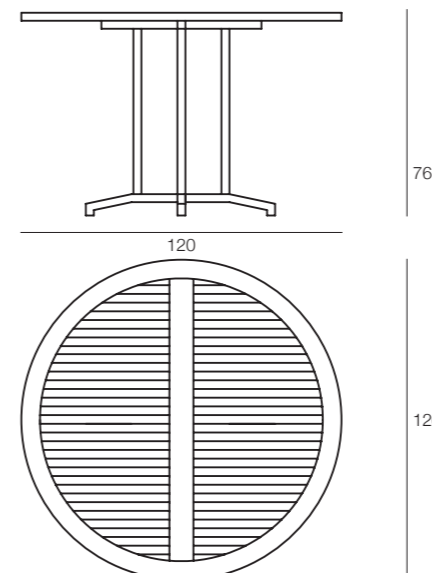

CAPRICCIO

BAMBOO AND NATURAL RATTAN FINISHING

Capriccio è una collezione leggera come i materiali che utilizza: la canna di Malacca, delicato e allo stesso tempo robusto; il rattan naturale e la corda sono invece l'intreccio che regge queste strutture ariose. Tutti gli arredi lasciano vedere la loro struttura, sempre curva e morbida, senza rinunciare alla solidità e al comfort dato dal design ergonomico e aiutato dalla presenza dei cuscini per divani e sedute. Il dettaglio della corda blu, usata per caratterizzare i punti di giunzione, è il "capriccio" che dà il nome alla collezione.

Capriccio is a collection as light as the materials it uses: the rattan pole, delicate and at the same time robust; the natural rattan skin and the rope are the braiding that supports these airy structures. All the furnishings show their structure, always curved and soft, without sacrificing the solidity and comfort given by the ergonomic design and helped by the presence of cushions for sofas and seats. The detail of the blue rope, used to characterize the junction points, is the "whim" that gives its name to the collection.

CAPR0293



CAPR0293

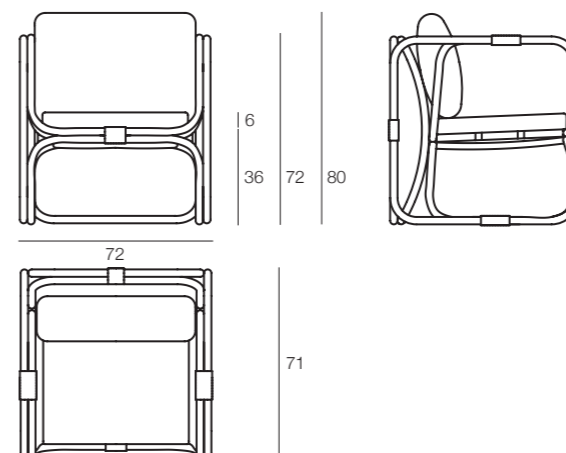

DETTAGLI CHE FANNO LA DIFFERENZA - ACCENT DETAILS

La corteccia della canna di Malacca viene tradizionalmente usata per assicurare tra loro le diverse parti della struttura degli arredi in midollino. Per impreziosire la collezione Capriccio, questo dettaglio è stato sostituito con corda colorata, disponibile in diverse colorazioni e melange.

Rattan skin is traditionally used to fasten the different parts of natural wicker furniture.

To enhance the Capriccio collection, this detail has been replaced with coloured rope, available in different colours and melange.



CAPR0294



CAPR0294

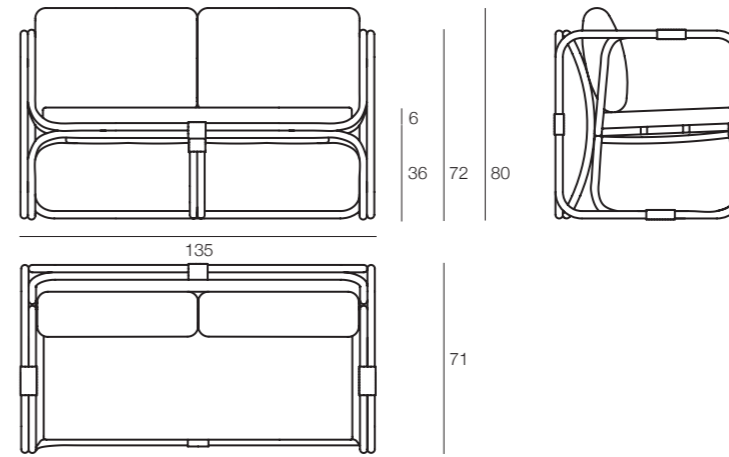

CAPR0394



CAPR0394

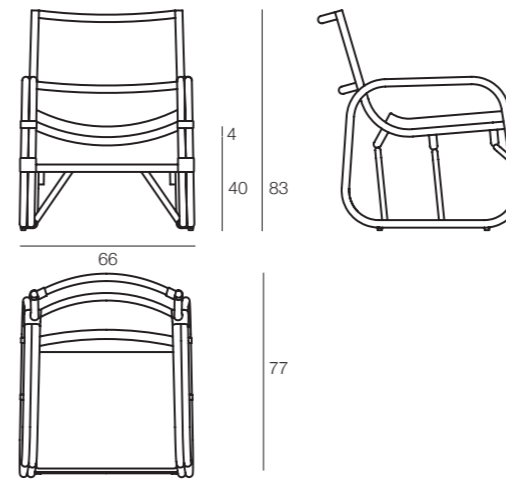

CAPR04D4



CAPR04D5



CAPR04D4

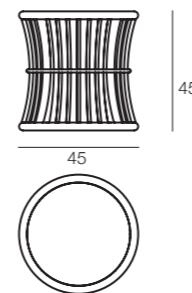

CAPR04D5

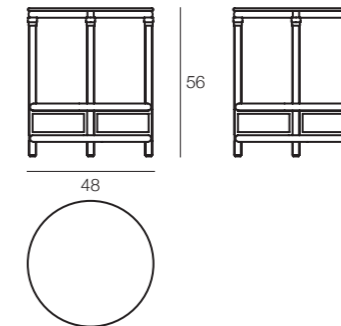

CAPR04F4



CAPR04F4

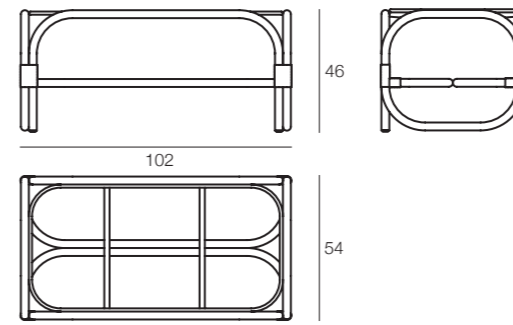

CAPR04F5



CAPR04F6



CAPR04F5

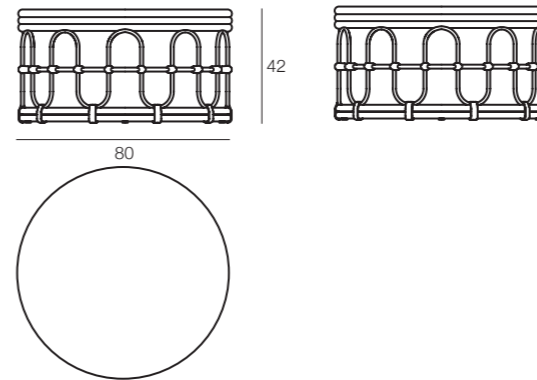

CAPR04F6

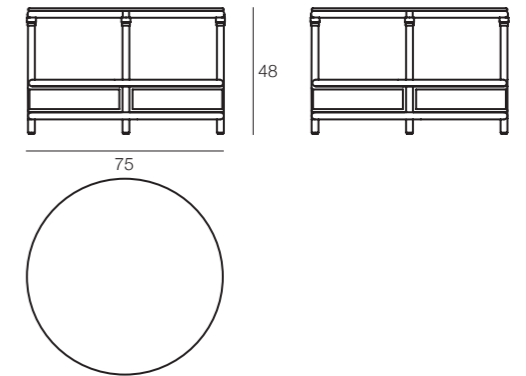

CAPR08B9



CAPR08B9

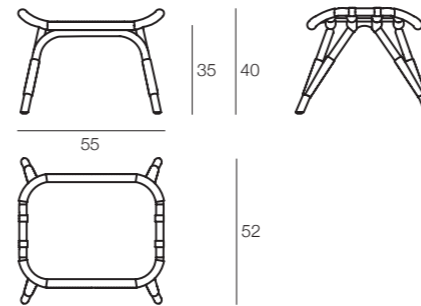

CAPR04H1



CAPR04H1

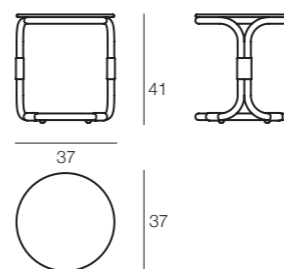

CLASSICA

full collection: CATALOGO GENERALE

Design e materiali legati alla tradizione e grande varietà di misure e accessori disponibili. Interamente realizzata in legno massello di teak a finitura naturale o oliata con ferramenta in ottone. Le panchine, con o senza schienale, sono disponibili in differenti misure.

Tradition-bound design and materials and a wide choice of sizes and accessories. Entirely made solid teak wood Fine Sanded or oiled finishing and brass hardware. The benches, with or without backrest, are available in various sizes.

CLAS0878_DO



CLAS0878

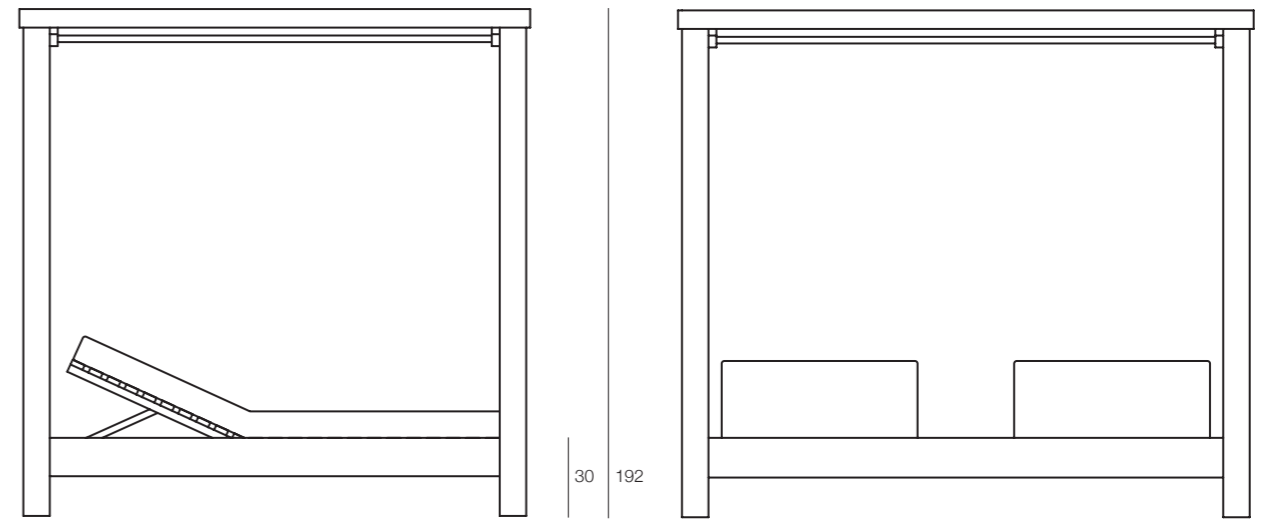

CLAS04G7



CLAS04G7

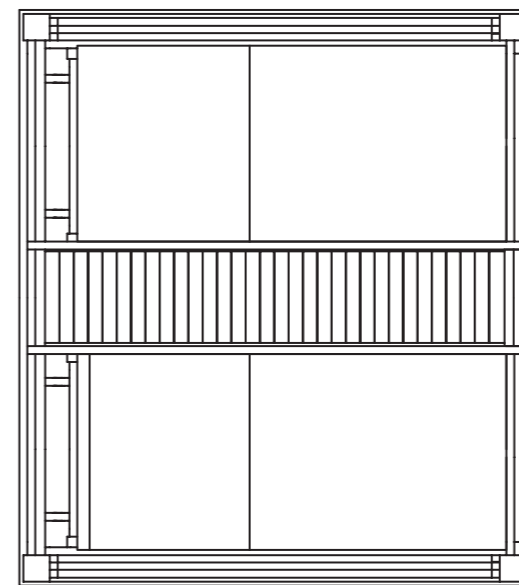
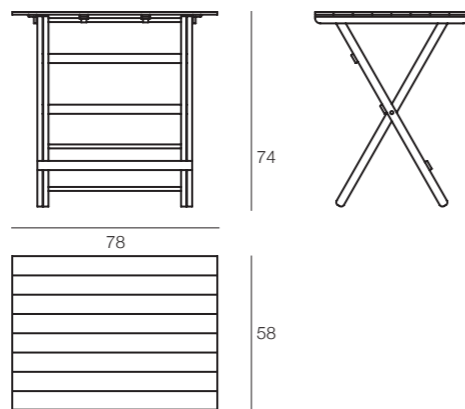

CLAS0218



CLAS0219



CLAS0218

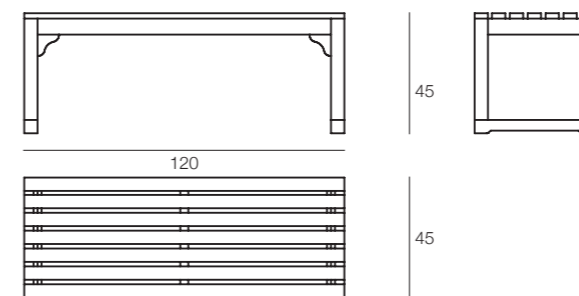

CLAS0219

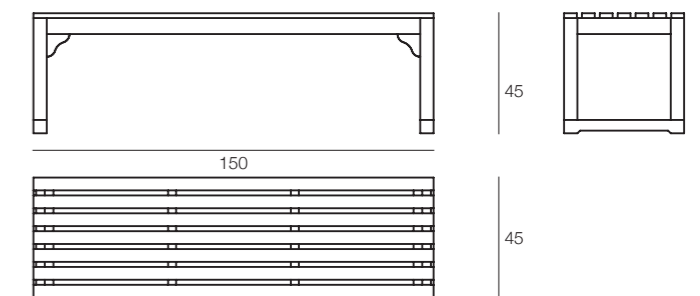

CHARPAI

design by CRS Silat

Struttura in Teak a finitura effetto riciclato con intreccio in corda da esterno in vari colori. I modelli proposti sono bianco e nero alternati con motivo a rombo, rosso, grigio, arancio e natural alternati a ecru con motivo a spina di pesce longitudinale; Natural ed ecru con motivo a spina di pesce trasversale. Oppure nella versione in giacinto d'acqua sintetico ad intreccio aperto, denominato Bali.

Structure in Teak with natural reclaimed wood finishing, with woven rope for outdoor use in various colors. The proposed models are white and black alternating with diamond, red, gray, orange and natural alternating with ecru with a longitudinal herringbone pattern; Natural and ecru with a transverse herringbone pattern, four fibers of Single Rope Hyacinth synthetic 5.4 mm with an open plot, called Bali.

CHAR02A8



CHAR02A8

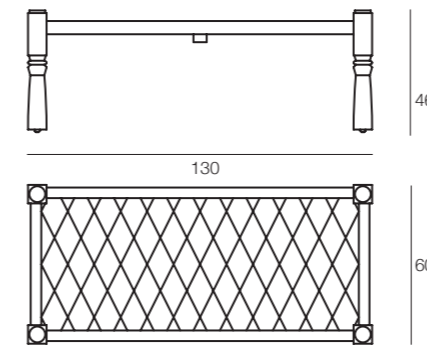

CHAR03B4

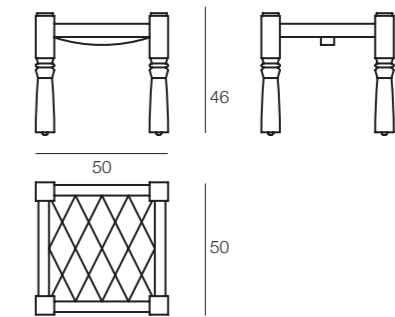

CHAR03B4



Black and white diamond weaving



Mixed colour "W" weaving



Natural zig-zag weaving

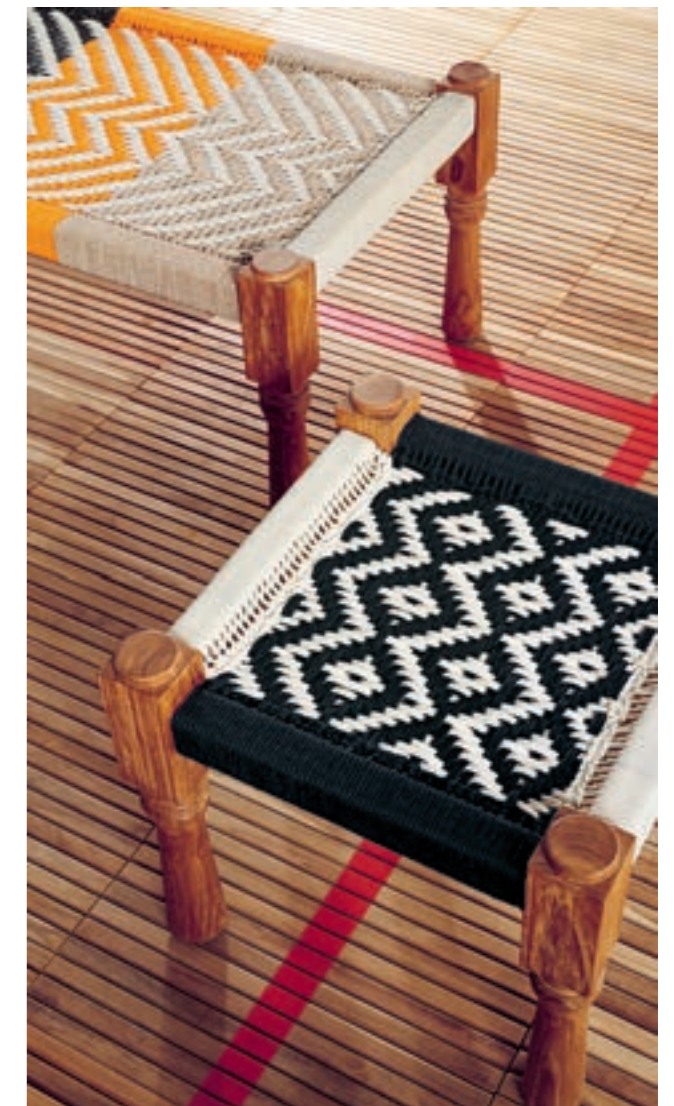

CHAR03B3



CHAR03B3

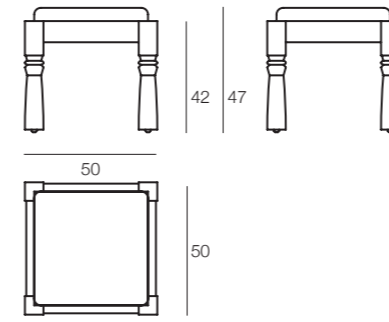

CHAR0571



CHAR0571

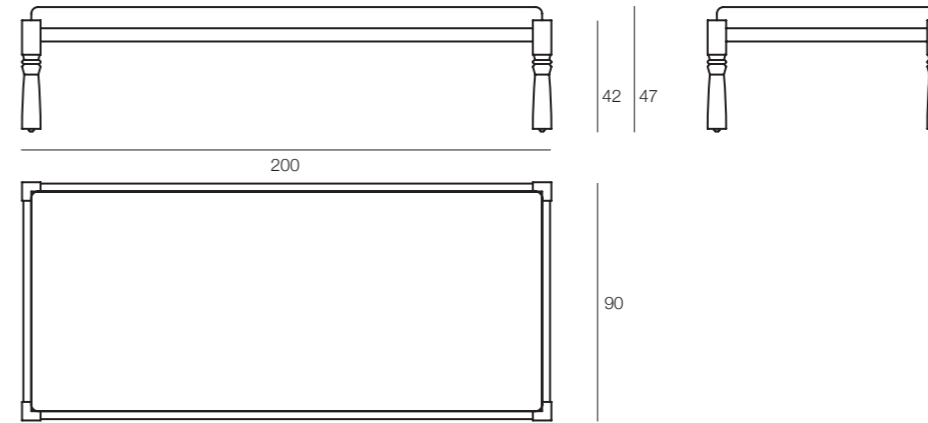

CHAR03B4



CHAR03B4

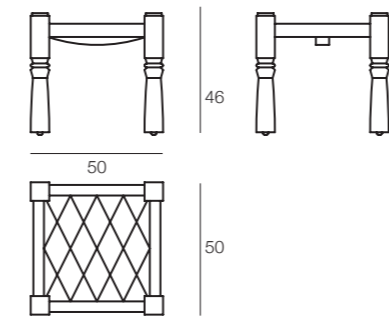

CHAR0572



CHAR0572

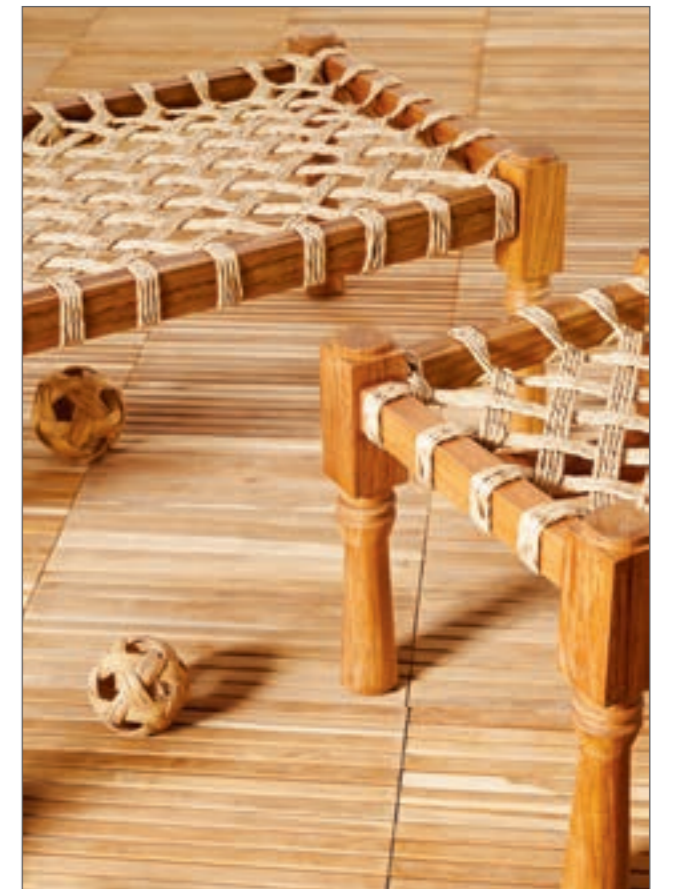
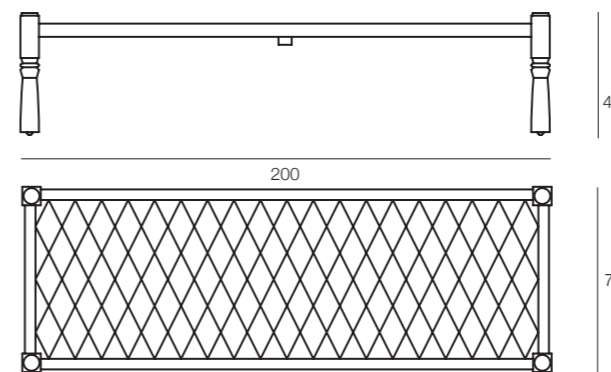

CODE

full collection: VIAGGIO TROPICALE

Struttura in legno di teak con finitura standard Fine Sanded a levigatura fine. I listelli in teak sono disposti in modo non simmetrico, con alcuni listelli più vicini tra loro e altri più lontani: in questo modo viene ricreato l'effetto del "codice a barre" (bar code) da cui la collezione trae il nome. I piani dei tavoli sono in marmo bianco, disponibile in varie forme e dimensioni a seconda del modello, o in teak.

The line is composed by pieces of furniture with a Fine Sanded teak wood structure. The teak slats are positioned in an asymmetric way: some of them are closer each other and some other are farther to create a "bar code" effect, after which the collection is named. The table tops are in teakwood or in white marble and are available in different shapes and dimensions, according to the model.

CODE0487



CODE0487

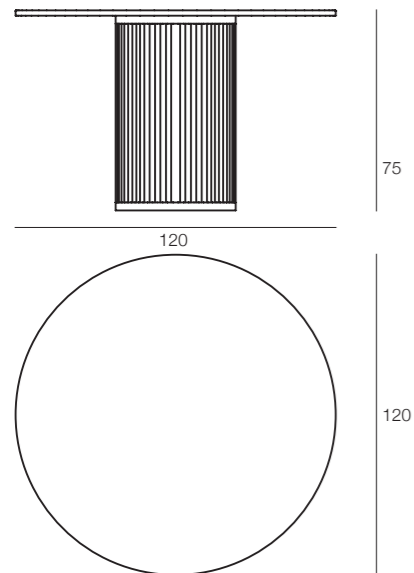

CORD

designed by CRS SILAT

La collezione Corda unisce la corda intrecciata, materiale che le dà il nome, con l'inimitabile teak, il legno perfetto per l'arredo outdoor e per il giardino, modellato in modo da essere leggermente curvo, quasi arcuato. Il look è classico, ma l'uso della corda rende la linea moderna e robusta, comoda e confortevole. Realizzata in Teak finitura oliata intreccio in corda color cenere.

The Corda collection combines the braided rope, the material after that it is named, with the inimitable teak, the perfect wood for outdoor furniture and for the garden, shaped to be slightly curved, almost arched. The look is classic, but the use of rope makes the line modern and robust, cosy and comfortable. Oiled teakwood frame and ash woven rope.

CORD0382



CORD0382

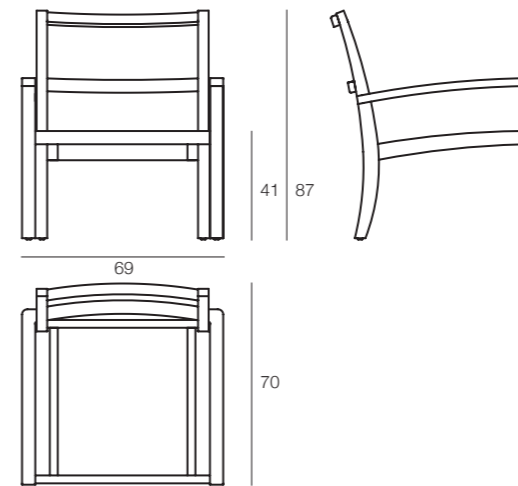

CORD08C1



CORD08C1

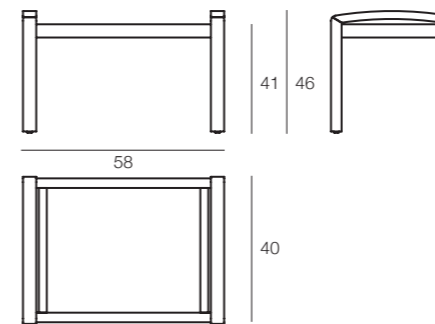

CORD02A3



CORD02A3

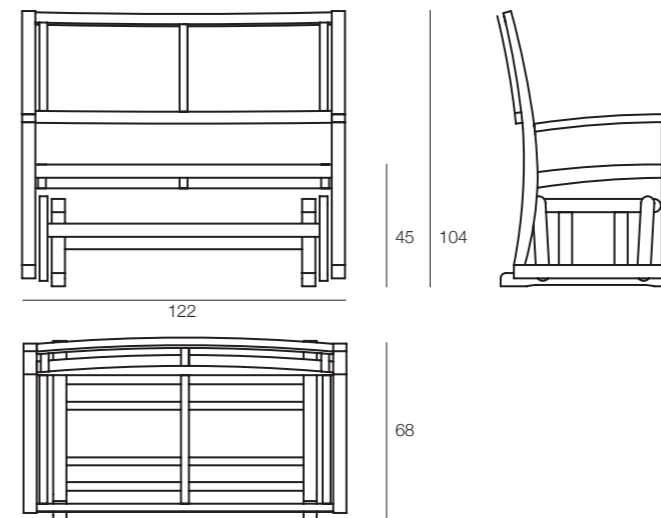

DESIRE

designed by CRS SILAT

Desire è una collezione interamente in rattan, un materiale versatile e senza tempo. Tutti gli arredi sono costruiti su una struttura fitta e regolare: il rattan forma una sorta di "armatura" che diventa accogliente nella poltrona e crea un assetto forte negli altri arredi, dando vita a un design che amerete al primo sguardo, un vero oggetto del desiderio

Desire is a collection entirely made in rattan, a versatile and timeless material. All the furnishings are built on a dense and regular structure: the rattan forms a sort of "armor" that becomes cozy in the armchair and creates a strong setting in the other furnishings, giving rise to a design that you will love at first glance, a true object of desire.

DESI0292



DESI0292

IC00720 - 042

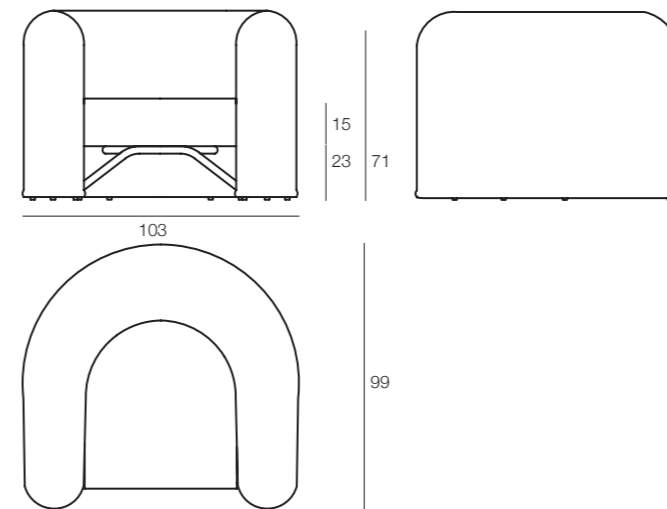

DESI04F7



DESI04F7

IC00721 - 043

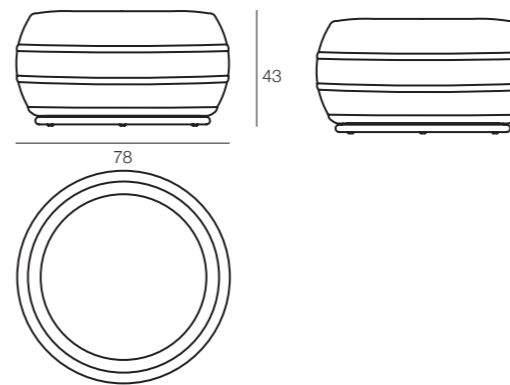

DESI08B8



DESI08B8

IC00731 - 058

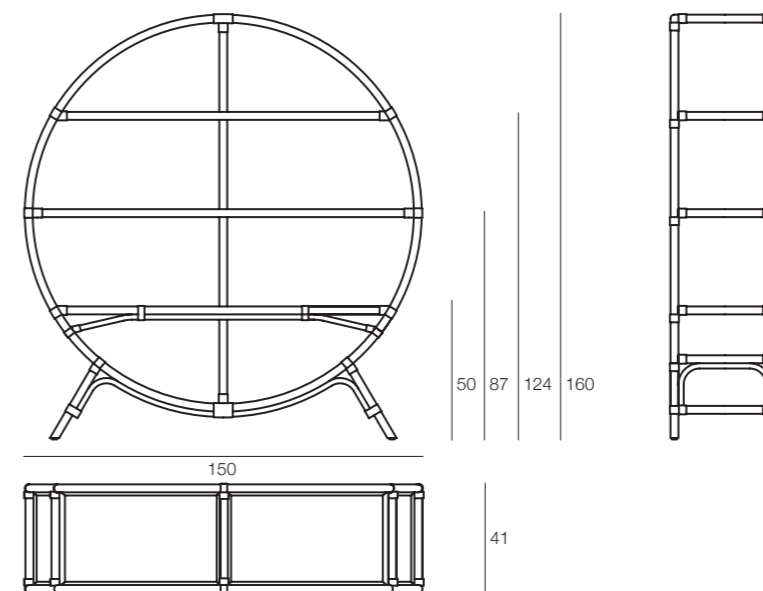

EMILY

full collection: CATALOGO GENERALE

La collezione Emily ha un design pulito e lineare, senza rinunciare all'eleganza formale. Tavolo: gambe e struttura in legno massello di Teak con finitura protettiva e piedini antigraffio in Teflon. Piano proposto in HPL o granito nero. Poltroncina: gambe e struttura in legno massello di Teak con finitura protettiva e piedini antigraffio in Teflon. Intreccio in fibra sintetica Core rotonda senza pigmentazione.

The Emily collection has a clean and linear design, without renounce to a formal elegance. Table: frame, legs and arms are made of weather-resistant Teak wood with a layer of protective finishing and non-scratch Teflon glides. Top in HPL or black granite. Armchair: frame, legs and arms are made of weather-resistant Teak wood with a layer of protective finishing and non-scratch Teflon glides. Woven with Core transparent wicker.

EMIL4322



EMIL0459



EMIL4322

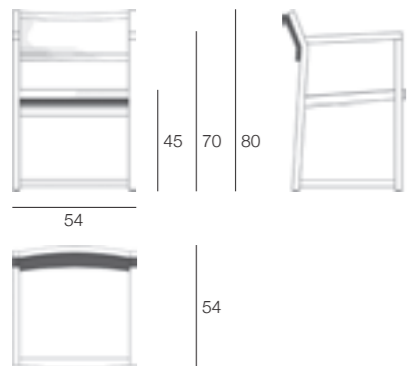

EMIL0459

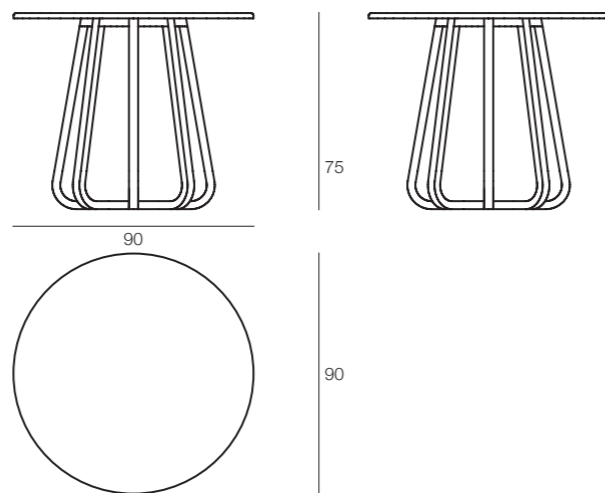

FAMIGLIA

design by STUDIO SALARIS

Gli arredi della collezione Famiglia conquistano per la graziosa combinazione dell'intreccio in corda che riveste la struttura in alluminio, disponibile nella variante grigia e arancio perlato. Gli intrecci, a volte laschi a volte strettissimi, che contraddistinguono le relazioni in una famiglia, insieme alla leggerezza e alla facilità di utilizzo di questa collezione hanno dato il nome alla serie di arredi Famiglia, che sono pensati come una solida struttura in metallo a cui la fibra intrecciata, una corda da esterno disponibile in vari colori, si aggancia e si sostiene.

The furnishings of the Famiglia collection are captivating thanks to the graceful combination of the rope weave that covers the aluminium structure, available in grey and naced orange. The interweaving, sometimes very tight, that characterize the relationships in a family, together with the lightness and ease of use of this collection have given the name to the series of furniture Family, which are designed as a solid metal structure to which the woven fiber, an outdoor cord available in various colors, hooks and supports.

FMGL03B2

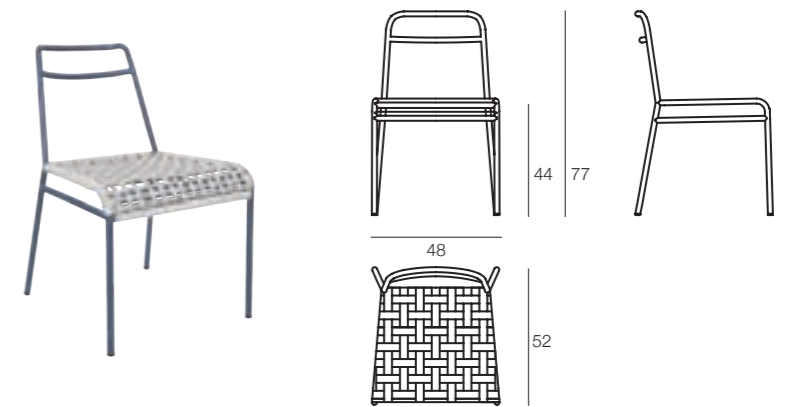

FMGL04H2

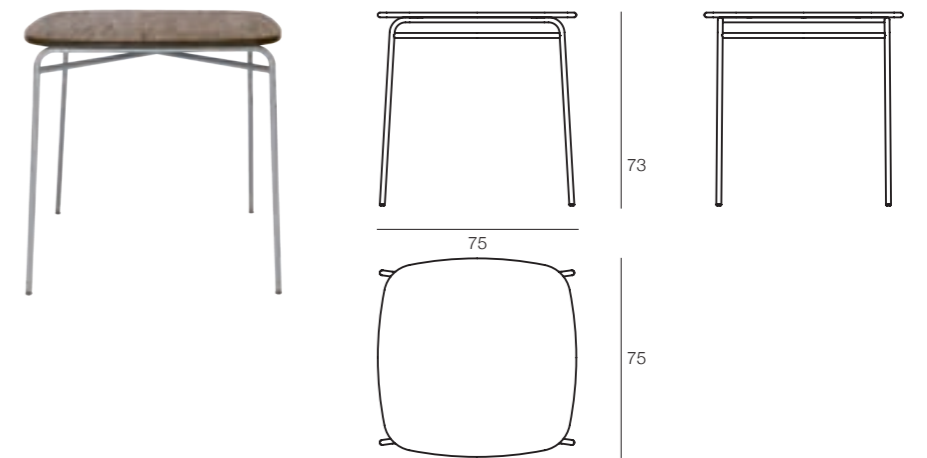

FMGL0570

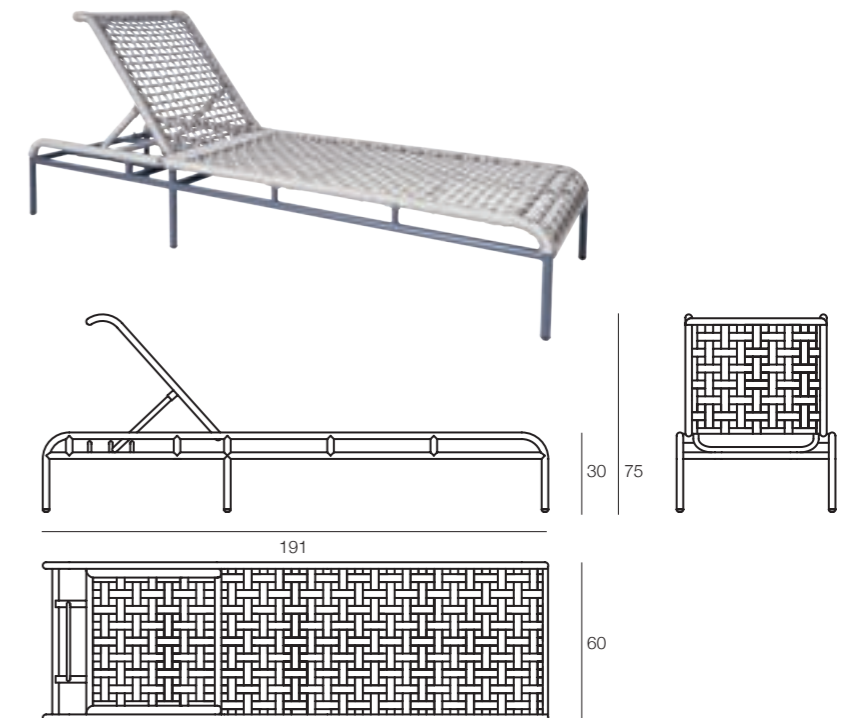

GIPSY

full collection: CATALOGO GENERALE

Il design anni sessanta e la grande eleganza formale sono i punti di forza di questa collezione dall'estrema comodità. Tavoli in massello di Teak proposti in finitura naturale.

Its Sixties design and great formal elegance are the main assets of this extremely comfortable collection. Tables with top and frames in solid Teak Standard with Fine Sanded finishing.

GIPS0461



GIPS0460



GIPS0461

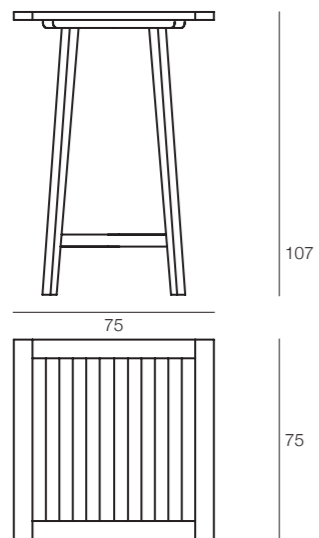

GIPS0460

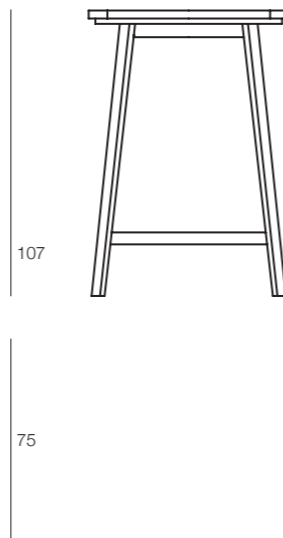
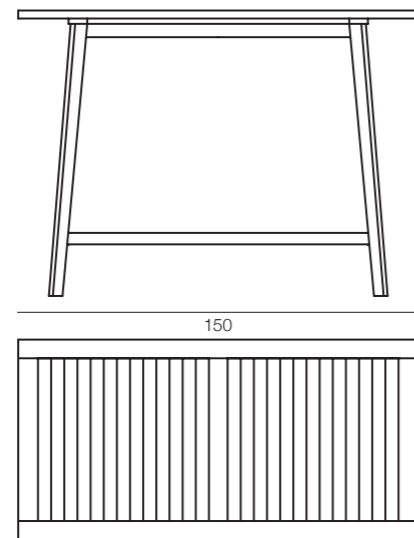

JENGA

designed by STUDIO SALARIS

Jenga è una collezione di tavolini e sgabelli ispirata ai tradizionali giochi in legno impilabili e in lingua swahili significa "costruisci!": un nome perfetto per una collezione di tavolini dal design inedito, dove le forme scultore e minimali, scavate nella materia, non sono altro che una ripetizione di moduli che si sovrappongono ritmicamente. Proposto in Suar finitura oliata.

Jenga is a collection of tables and stools inspired by the traditional stackable wooden games and in the Swahili language means "build!": a name perfect for a collection of tables with an original design, where the sculptural and minimal shapes, carved into the material, are nothing more than a repetition of modules that overlap rhythmically. Proposed in oiled wood finishing.

JENG04G2



JENG04G3



JENG04G4



JENG04G5



JENG04G2

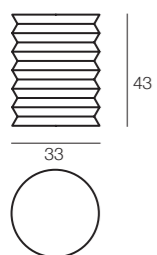

JENG04G3

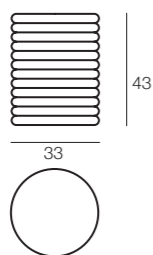

JENG04G4

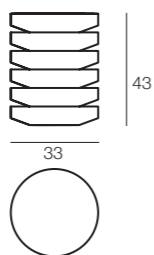

JENG04G5

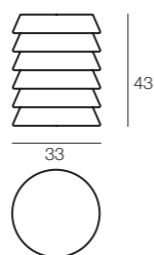

KARENITA

design by CRS SILAT

Sedia di tipo regista in legno di Teak con finitura a levigatura fine con schienale e seduta in batilene colore nero nella versione standard. Divano modulare con struttura in legno di Teak con finitura a levigatura fine e cuscino in poliuretano espanso a densità differenziata e dacron, con rivestimento colore denim per la versione standard.

Director chair in Teak wood with fine sanded finish with back and seat in black batilene in the standard version. Modular sofa with structure in Teak wood with fine sanded finish and cushion in differentiated density polyurethane foam and dacron, with canvas denim cover for the standard version.

KARE03A5

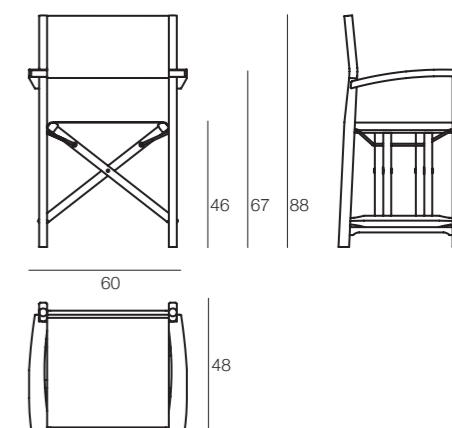

KARE02A7



KARE02A7

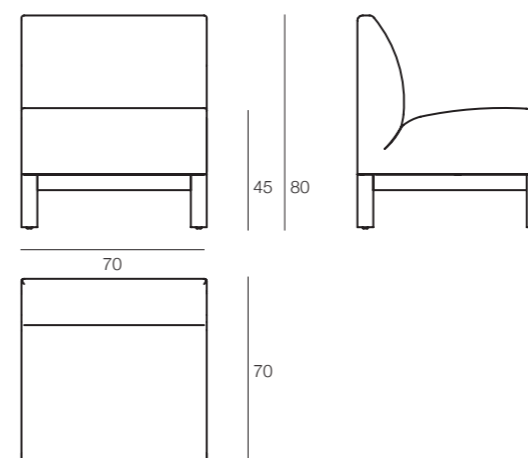

KARE08C2



KARE08C2

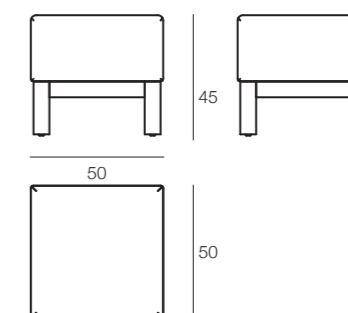

KROSS

design by CRS SILAT

Caratterizzata da forme geometriche e decise, con poche curve, per un design essenziale ed efficace. Struttura in legno massello di Teak sulla quale viene intrecciata una fibra estrusa di polietilene ad alta densità o pelle sintetica o naturale a scelta. Piedini antigraffio in Teflon. Le sedie dining della collezione sono disponibili con o senza braccioli. Proposto in Teak finitura decapata white wash e fibra sintetica colore White wash, oppure in Teak finitura oliata e intreccio in pelle.

Made of teak wood, with clean-cut geometrical shapes and minimalist curves for an essential, eye-catching design. Kross Collection has a solid Teak structure, hand-woven with Extruded High Density Polyethylene. Non-scratch Teflon glides. The dining chairs of this collection are available with or without armrests. Standard finishes are White wash teak wood and White Wash synthetic fibre, or oiled wood finishing and cognac color leather.

KROS03A5_TOPC



KROS03A5_WTWW



KROS03A6



KROS03A7



KROS03A8



IC00764 - 65 - 086

KROS03A5

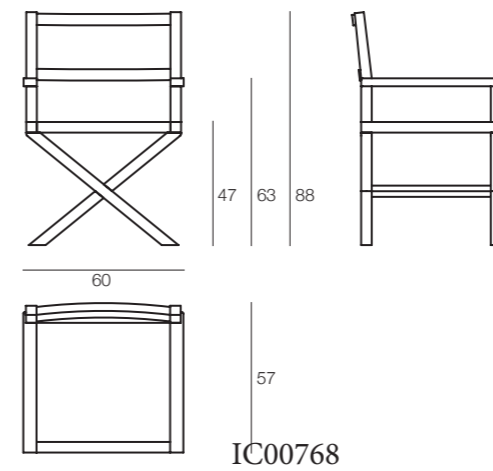

IC00768

IC00769

KROS03A6

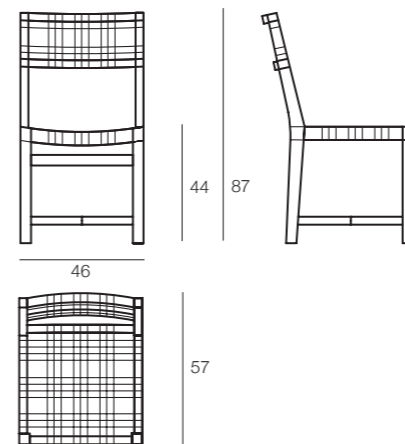

IC01080

KROS03A7

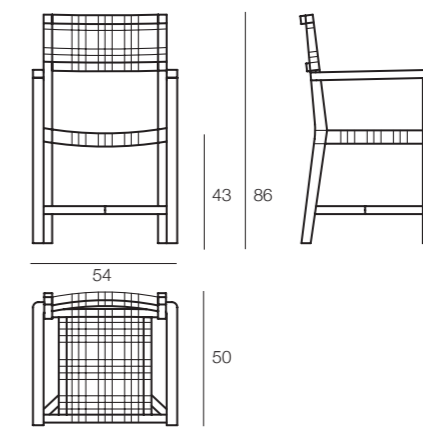

KROS03A8

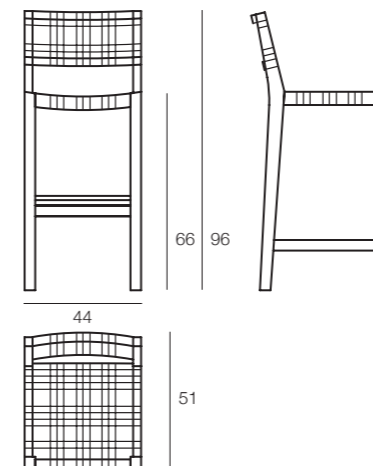

MACRAME'

design by CRS Silat

Corda acrilica da esterno, proposta in colorazine ecrù, intrecciati e annodati a mano con la tecnica del macramè. Componenti in legno con finitura oliata. Cuscini da pavimento con imbottitura in polistirene espanso oppure in gommapiuma ecologica, in quanto ottenuta da ritagli avanzati da altre lavorazioni che altrimenti andrebbero sprecati.

Outdoor acrylic rope, proposed in ecru colors, woven and knotted by hand with the macramé technique. Wood components with oiled finish. Floor cushions with lining in expanded polystyrene or in ecological foam rubber, as obtained from leftover scraps from other processes that would otherwise be wasted.

MACR0573



MACR0574



MACR0573

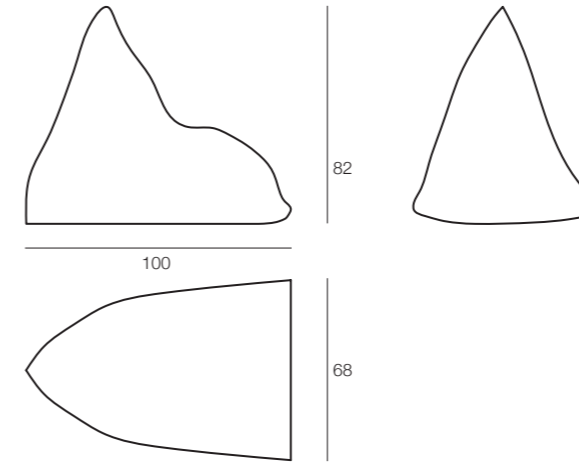

MACR0574

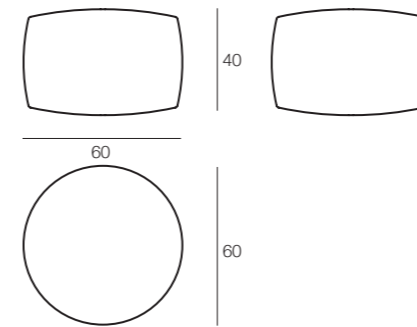

MACR08C3



MACR08C4



MACR08C3

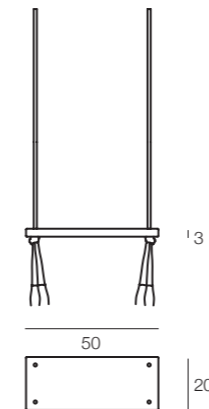

MACR08C4

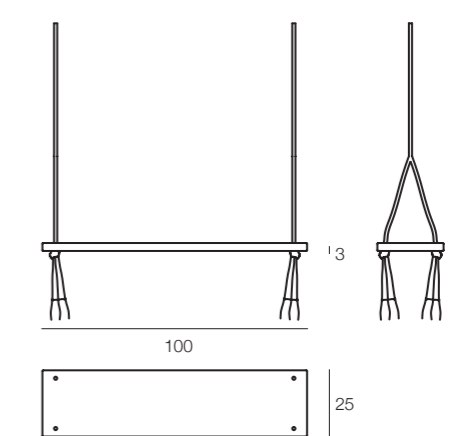

ZOCM2500



ZOCM2500

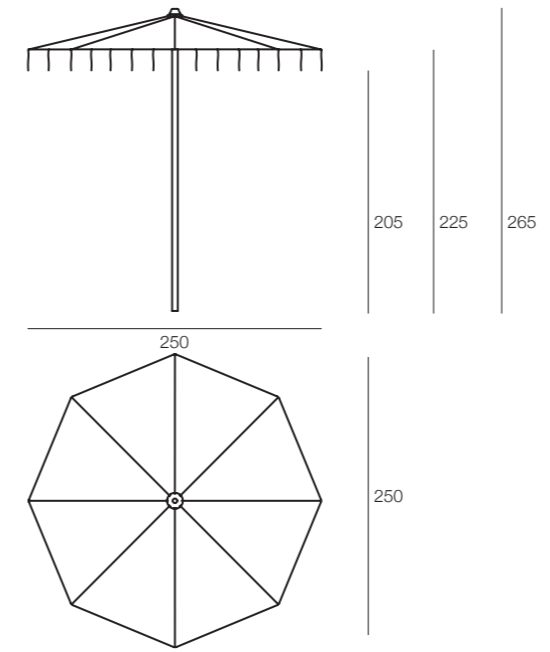

VENE0507



VENE0854



VENE0507

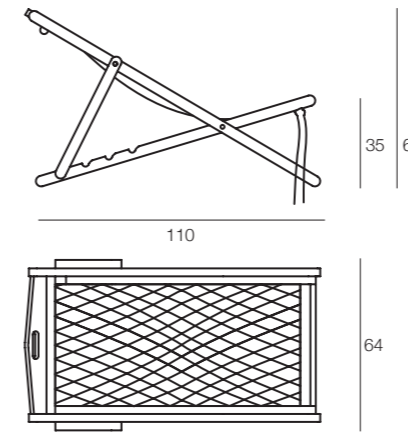

VENE0854

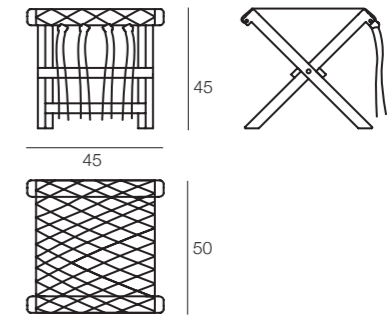

MACR08C5



MACR08C5

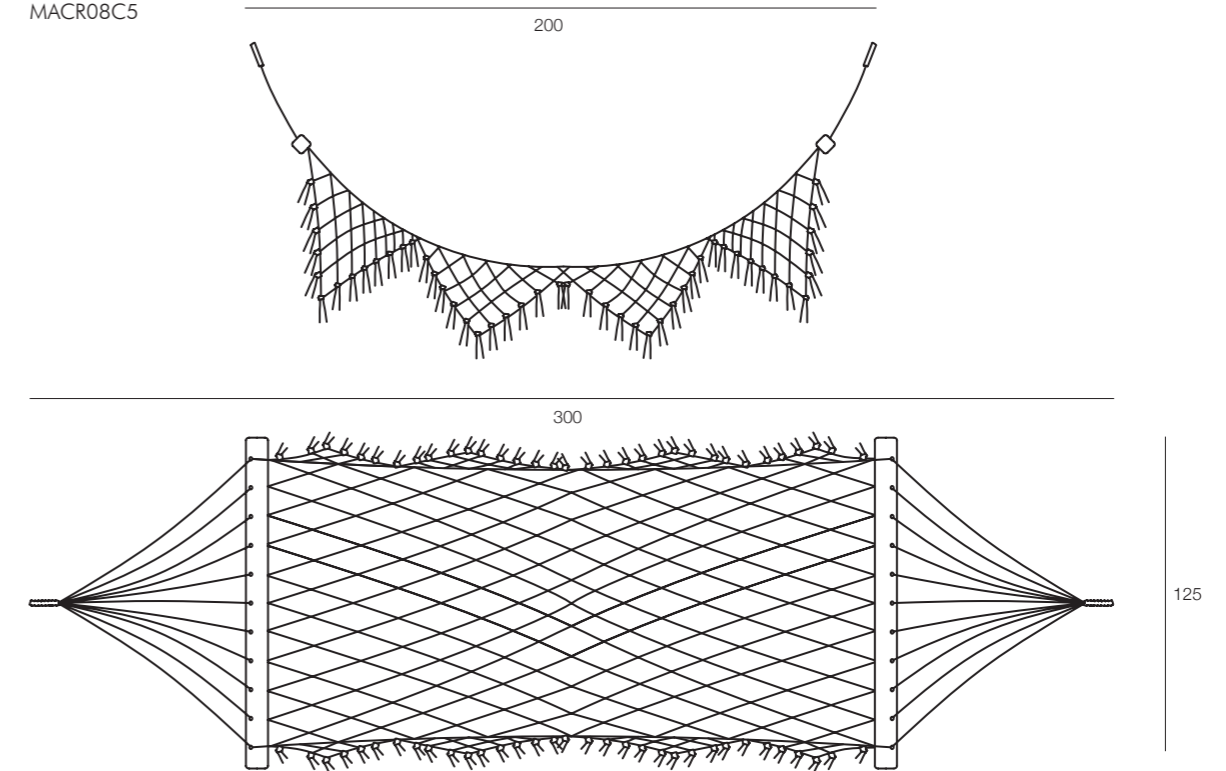

NANTO

design by CRS Silat

Sedia e tavolino in legno di teak finitura olio e cera opaca e tavolino con ripiano in vetro satinato. Seduta imbottita in poliuretano espanso e rivestimento ecrù per la versione standard. Lavorazione artigianale per ogni singolo pezzo. Un amore profondo per le finiture e le lavorazioni che solo i maestri artigiani sanno realizzare.

Teak wood chair and coffee table with oil and matt wax finish and coffee table with satin glass top. Upholstered seat in polyurethane foam and ecru cover for the standard version. Craftsmanship for each piece. A deep love for finishings and workmanship that only master craftsmen know how to make.

NANT03B6



NANT0413



NANT03B6

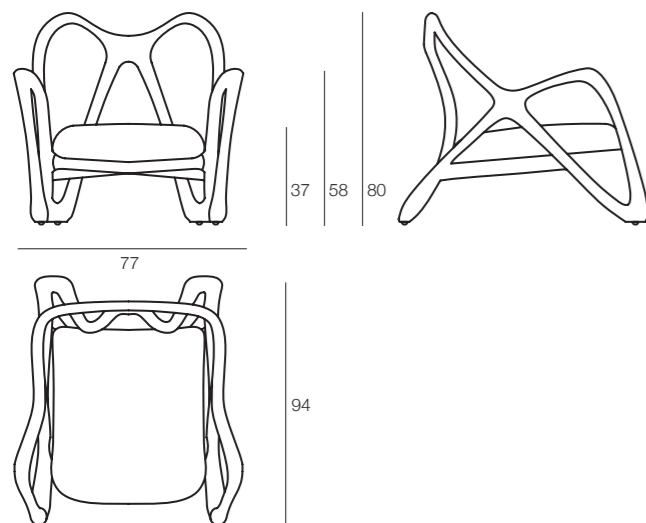

NANT0413

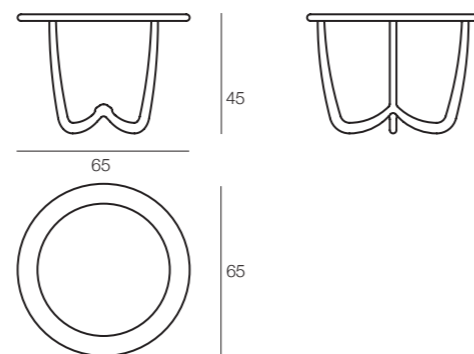

PALEOLITICA

designed by STUDIO SALARIS

I vasi decorativi in legno di Teak della linea Paleolitica richiamano i primi manufatti prodotti dall'uomo, la loro semplicità e bellezza. Attraverso forme pure e primordiali, scavate fra le irregolarità, investigano l'assenza di materia che la radice porta con sé. Le molteplici forme e dimensioni fanno sì che questi complementi siano perfetti per ambienti e spazi molto diversi, nessun oggetto è perfettamente uguale all'altro e ogni pezzo è realizzato a mano presentando caratteristiche di unicità. Proposti in finitura protettiva o legno nero vulcanizzato

The decorative vases in Teak wood of the Paleolitica line recall the first artifacts produced by man, their simplicity and beauty. Through pure and primordial forms, dug between irregularities, they investigate the absence of matter that the root carries with it. The multiple shapes and sizes make these complements perfect for very different environments and spaces, no object is perfectly equal to each other and each piece is handmade presenting unique characteristics. Standard finishings are protective -or black vulcanized wood finishing.

PALE0883



PALE0885



PALE0887



PALE0889



PALE0891



PALE0893

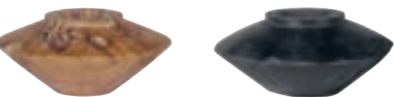

PALE0895



PALE0897



PALE0899



PALE08A2



PALE08A4



PALE0883

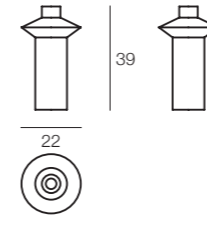

PALE0885

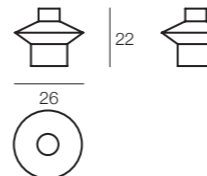

PALE0887

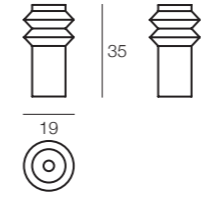

PALE0889

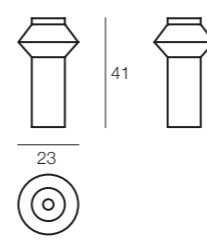

PALE0891

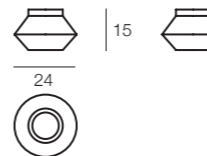

PALE0893

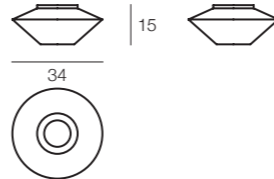

PALE0884

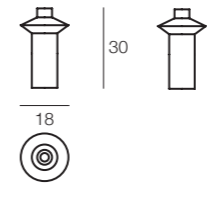

PALE0886

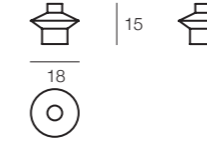

PALE0888

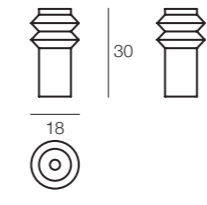

PALE0890

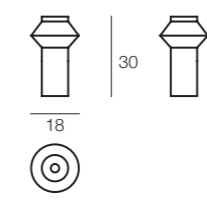

PALE0892

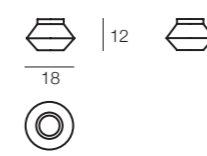

PALE0894



PALE0895

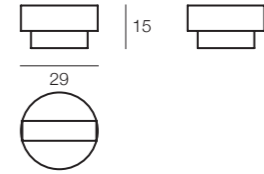

PALE0897

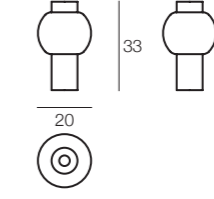

PALE0899

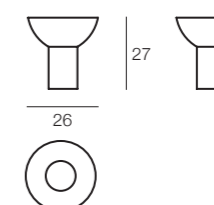

PALE08A2

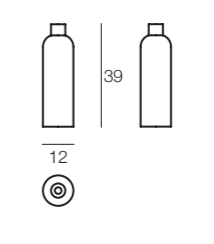

PALE08A4

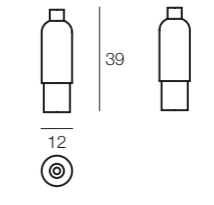

PALE0896

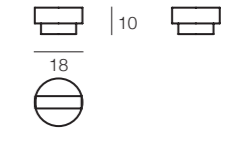

PALE0898

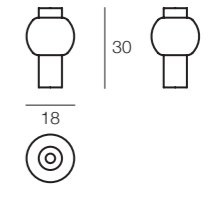

PALE08A1

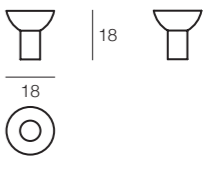

PALE08A3

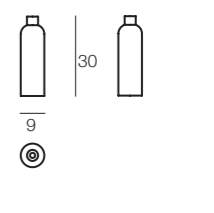

PALE08A5

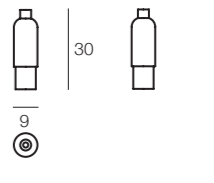

PENINSULA

design by CRS Silat

Legno di Teak o Mogano con finitura "mahogany yacht" Divano e poltrona con schienale con corda acrilica colore blu nella versione standard, tavolini con piano in marmo bianco. Sedia sdraio e tavolino pieghevole con ferramenta in acciaio. Sedute con cuscino in poliuretano espanso a densità differenziata e dacron, con rivestimento ecrù per la versione standard.

Teak or Mahogany wood with finish mahogany red. Sofa and armchair with back with blue acrylic rope in the standard version, coffee tables with white marble top. Deck chair and folding table with steel hardware. Seats with cushion in differentiated density polyurethane foam and dacron, with ecru cover for the standard version.

PNSL02B1



PNSL02B1

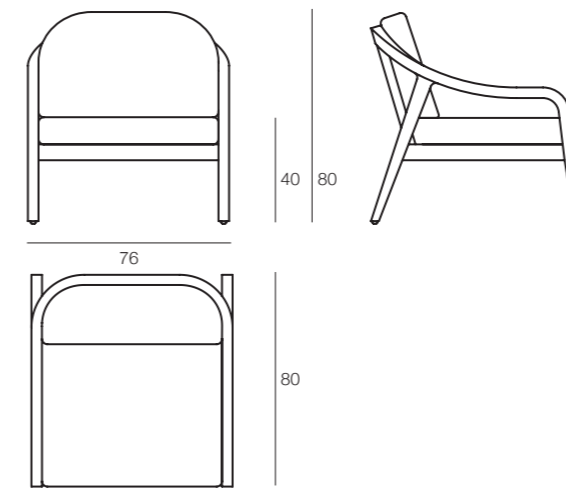

PNSL02A9



PNSL02A9

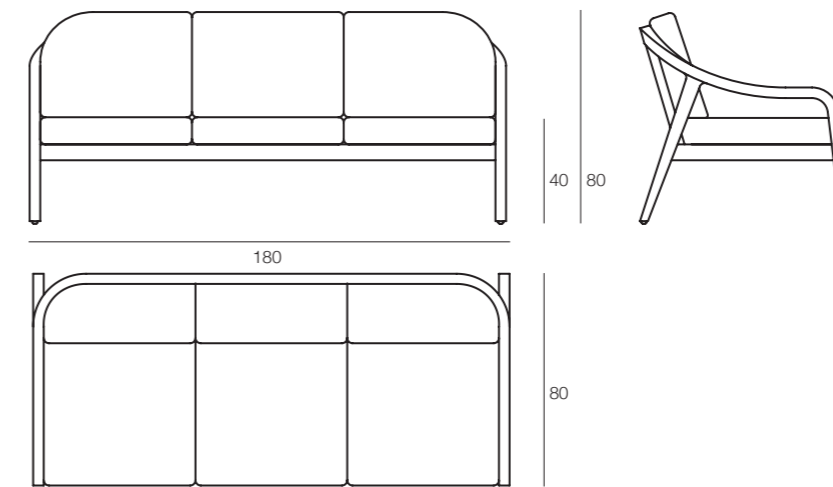

PNSL04H7



PNSL04H3



PNSL04H7

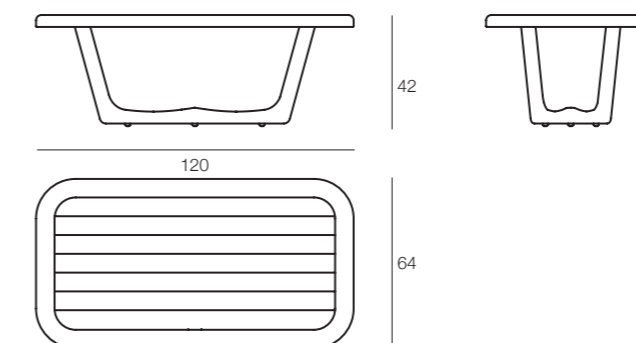

PNSL04H3

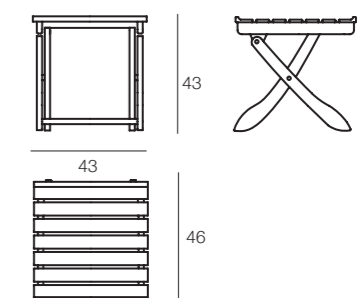

PNSL04H5



PNSL04H6



PNSL04H5

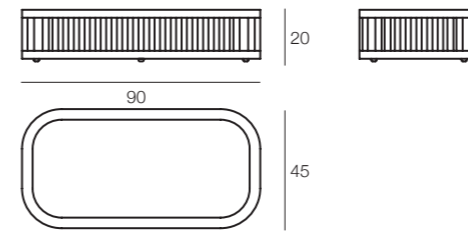

PNSL04H6

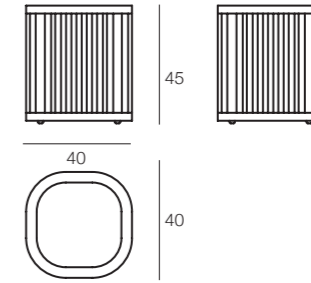

PNSL0576



PNSL0576

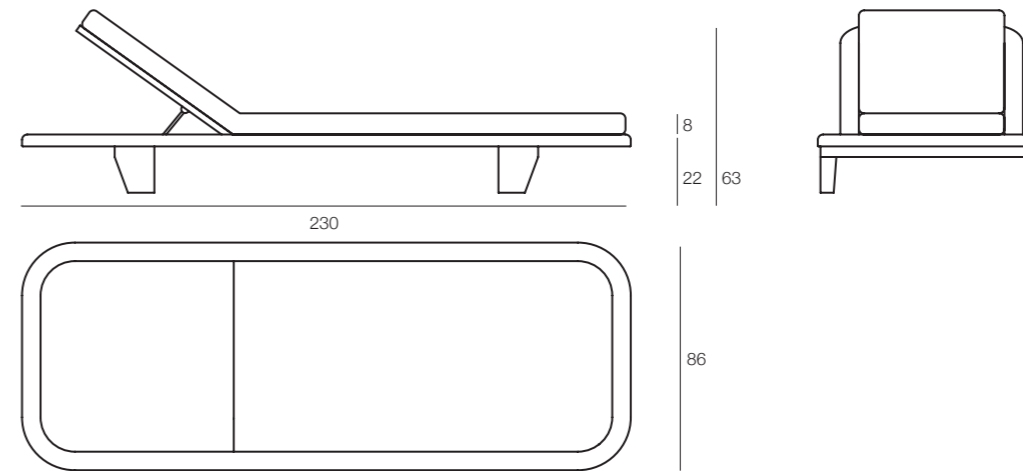

PNSL0575



PNSL08C6

PNSL0575

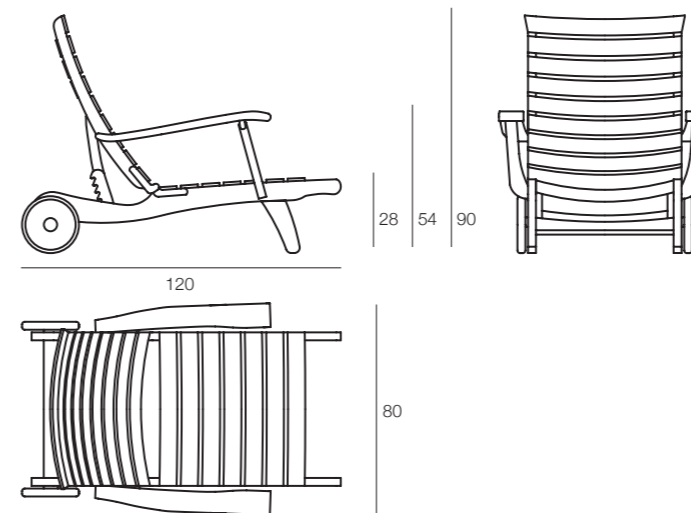

PNSL08C6

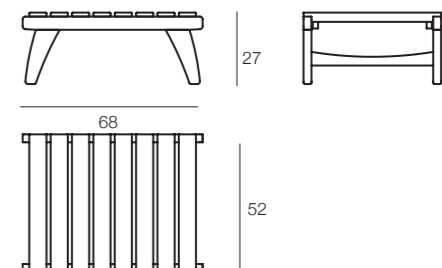

PHOEBE

designed by STUDIO SALARIS

Phoebe è una collezione in legno di Suar: tavolini dalla peculiare forma "a clessidra", caratterizzati da una vita sottile in centro che permette di spostarli con facilità, oltre ad essere estremamente accattivante per il suo look insolito ed elegante. Il legno conserva tutta la sua matericità, mentre le forme curve donano eleganza e morbidezza all'insieme. Disponibili in diverse misure e simmetrie. Proposto in finitura oliata.

Phoebe is a Suar wooden collection: tables with a peculiar "hourglass" shape, characterized by a slim waist in the center that allows you to move them easily, as well as being extremely eye-catching for its unusual and elegant look. The wood preserves all its materiality, while the curved shapes give elegance and softness to the whole. Available in different sizes and symmetries. Proposed in oiled finish.

PHOE04F3

PHOE04F2



PHOE04E9

PHOE04F1

PHOE04F2

PHOE04F3

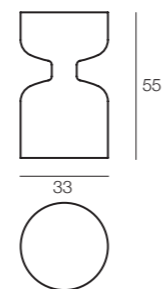
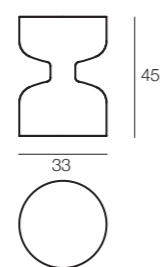
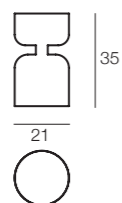
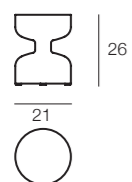

RADICE

design by NATURE

Questi arredi in Teak sono oggetti unici, recuperati dalle radici e da tronchi usurati dal tempo e rifiniti seguendo la loro natura. Il tavolino è proposto in finitura protettiva e gambe in metallo con finitura a polveri nera opaca ruvida.

Teak items with unique shapes, recovered from naturally worn roots and logs, well-finished following their natural elements. Standard version of the side table with a layer of protective finishing and black doff powder coated metal legs.

RADI0497



RADI0497

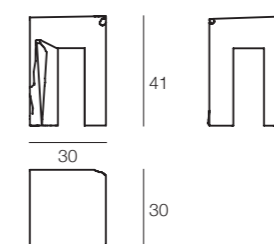

RADI04E1



RADI04E1

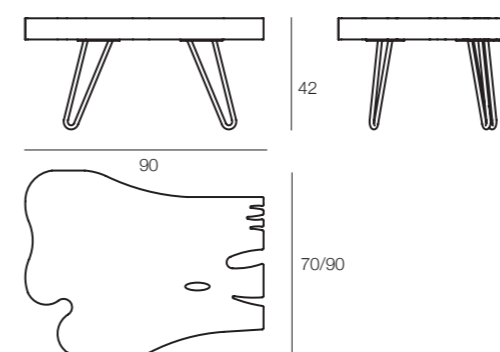

REMIX

design by CAMILLA LAPUCCI E LAPO BIANCHI LUCI

La linea presenta numerosi prodotti fatti da più materiali, anche molto diversi tra loro, uniti da un design armonico e unitario. Accessori, vasi e tavolini vengono creati con diversi tipi di legno: il teak e il suar, ma anche il mogano e il legno di palma, con finiture protettive o finitura a polveri nera ruvida per un effetto particolare e molto decorativo.

The lines present different products made of various materials, very different from each other, but joined together by a harmonic and unitary design. Accessories, flowerpots and coffee tables are created with different types of wood: teak and suar, but also mahogany and palm wood, with protective finishing or black doff powder coated finishing for a peculiar and very decorative effect.

RMIX041A



RMIX03A9



RMIX0376



RMIX04G6



RMIX04E2



RMIX045A



RMIX0563



RMIX041A

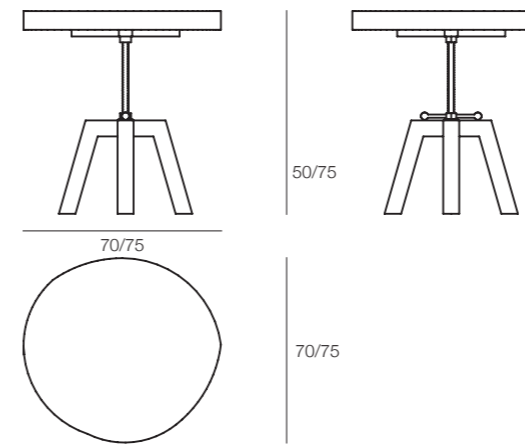

RMIX03A9

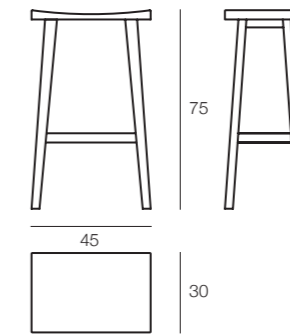

RMIX0376

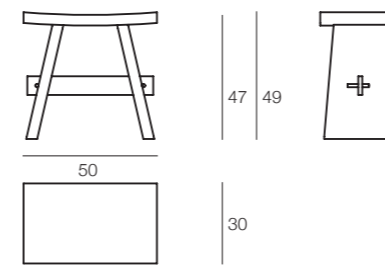

RMIX04G6

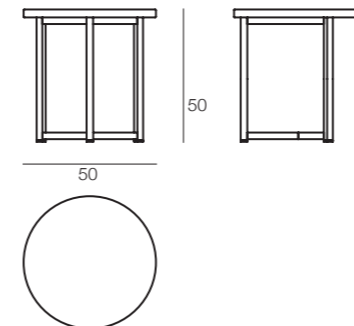

RMIX04E2

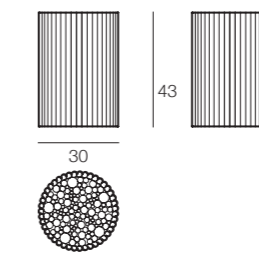

RMIX045A

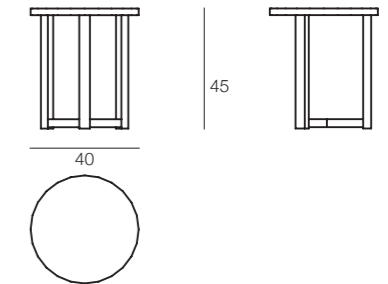

RMIX0563

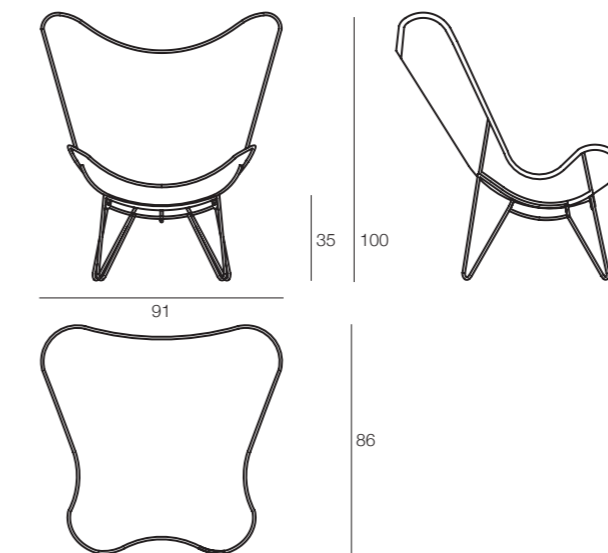

RING

ROUND SECTION TEAK FRAME

Questa collezione di mobili sono tutti caratterizzati da forme pulite e strutture poco invadenti. Divani e poltrone di diverso tipo con linee semplici e geometriche adatte ad ogni ambiente. Collezione realizzata interamente in legno di teak con finitura a levigatura fine naturale e Olio di Teak. Tavolini in due misure completano la collezione, pensata per spazi esterni contract o privati, anche di dimensioni contenute. Cuscini proposti con bordo alla francese.

All the pieces of furniture of this line feature clean shapes and not interfering structures. Different sofas and armchairs with simple and geometrical lines, suitable for any space. Collection entirely realized in fine sanded teak wood with Teak Oil finishing. Two sizes of side tables complete the collection, designed for contract or private outdoor spaces, even the small ones. Cushions with french seam.

RING0567



RING0568



RING0567

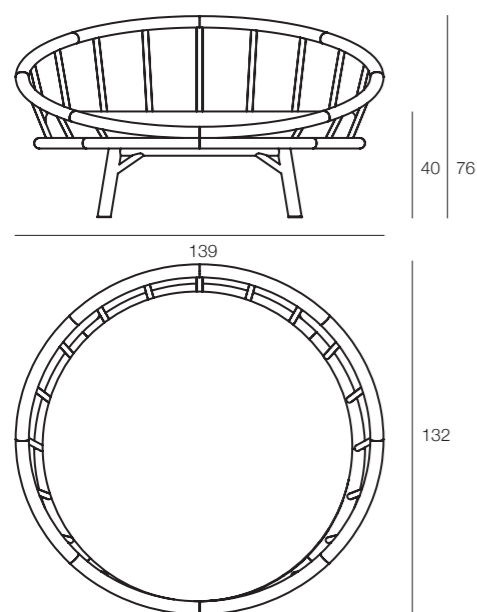

RING0568

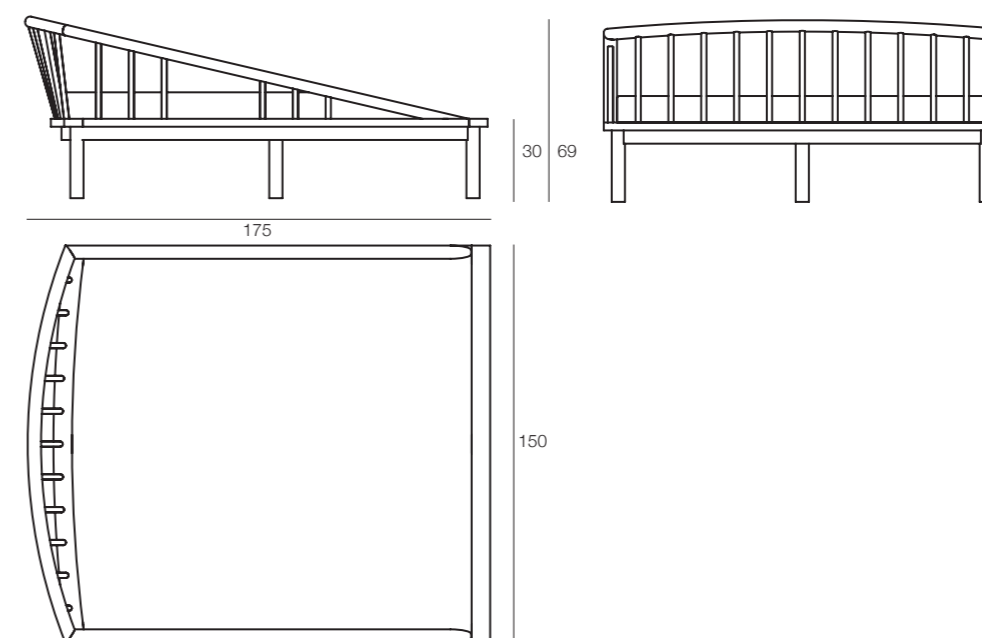

SAINT RAPHAEL

ADDENDUM full collection: CATALOGO GENERALE

La collezione Saint Raphael è perfetta per chi ama le strutture solide e robuste in legno di Teak e non vuole rinunciare ad uno stile elegante ed essenziale. Tavolo con piano in HPL e disponibile su richiesta in altre finiture. Lettini con ruote in Teflon e cuscinetti a sfera, ideali per pavimenti piani. Personalizzazioni per posizionamento in spiaggia da effettuarsi su richiesta. Il legno è proposto in finitura a levigatura fine naturale.

The Saint Raphael collection is perfect for those who love solid and sturdy structures in Teak wood and do not want to renounce to an elegant and essential style. Table with HPL top and other finishes available on request. Sun loungers with Teflon wheels and ball bearings, ideal for flat surfaces. Customisations for positioning on beach available on request. Fine Sanded is the standard wood finishing.

STRA0711_FS + ACCS0834_LB



STRA0711_FS + ACCS0834_LB

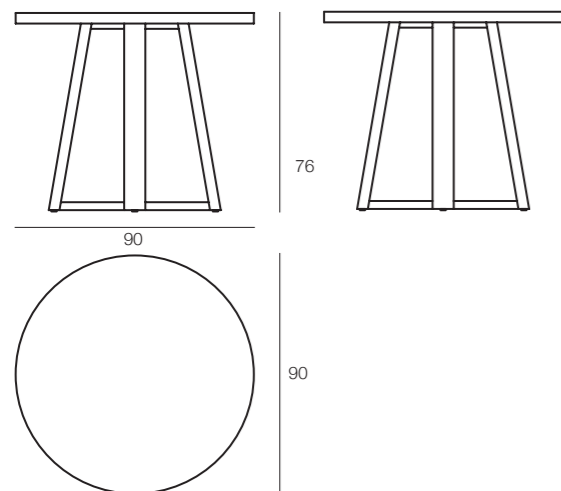

SAVANA

full collection: CATALOGO GENERALE

Realizzata in massello di Teak, è una collezione di sedute e tavolini da esterno con una linea discreta e funzionale. I tavoli bassi sono disponibili anche con doppio ripiano. I divani e le poltrone sono forniti con ampi cuscini sfoderabili in tessuto acrilico da esterno. Gli sgabelli alti, disponibili con o senza schienale, sono minimali e lineari nella forma e comodissimi nell'utilizzo, così come le sedie sdraio pieghevoli. Il legno è proposto in finitura a levigatura fine naturale.

A collection of solid Teak chairs and tables for outdoor use with an understated, functional design. The low tables are also available with double top. The cushions of the sofas and chairs are fully removable and made of acrylic fabric suitable for outdoor use. The high stools, available with or without backrests, are minimal and linear in shape and comfortable to use as well as the folding deck chairs. Fine Sanded is the standard finishing.

SAVA0427



SAVA0428



SAVA0467



SAVA0427

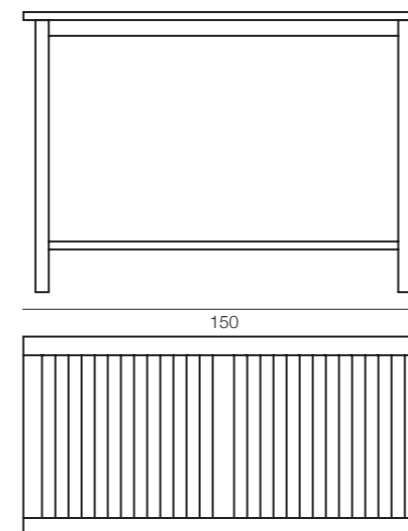

SAVA0428

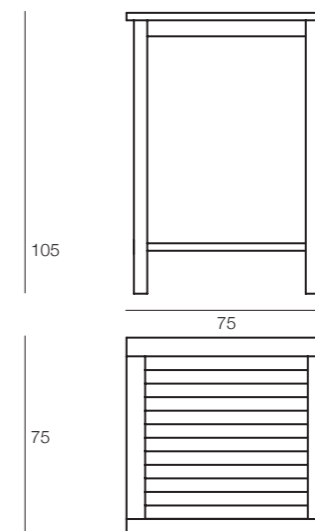

SAVA0467

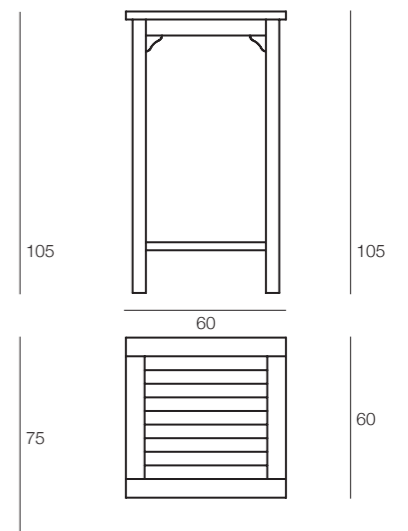

SERENGETI

designed by CRS SILAT

La linea Serengeti deve il suo nome al grande parco africano: il suo legno di teak è finito in modo da dare un effetto naturale, con un aspetto simile a quello dei tronchi d'albero e dei rami. L'altro materiale che caratterizza gli arredi Serengeti è la corda in Giacinto d'acqua sintetico, usato al naturale o ritorta.

The Serengeti line owes its name to the great African park: its teak wood is finished to give a natural effect, with an appearance similar to that of tree trunks and branches. The other material that characterizes the Serengeti furnishings is the synthetic water hyacinth rope, used natural or twisted.

SERE0297



SERE0298



SERE0299



SERE02A1



SERE0398



SERE0399



SERE0297

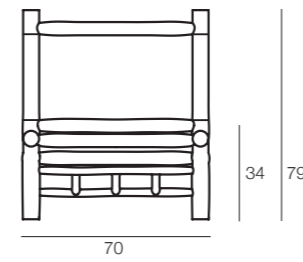

SERE0298

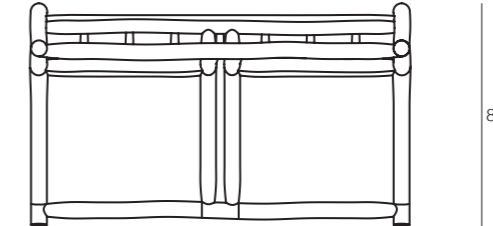
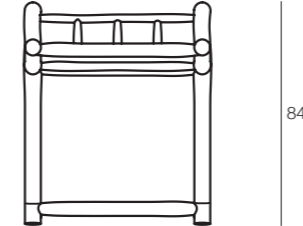
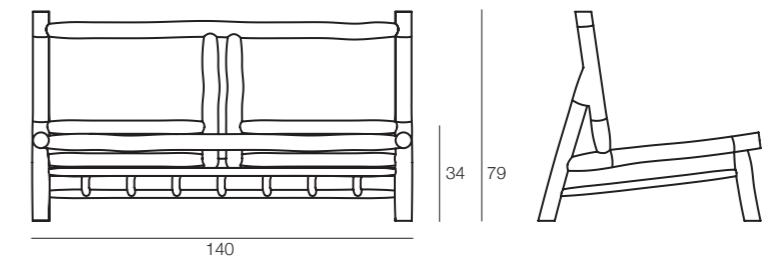

SERE0299

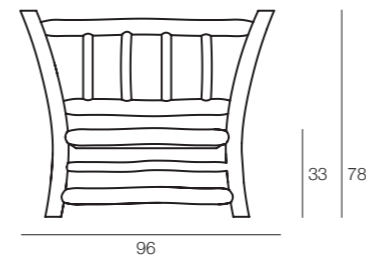

SERE02A1

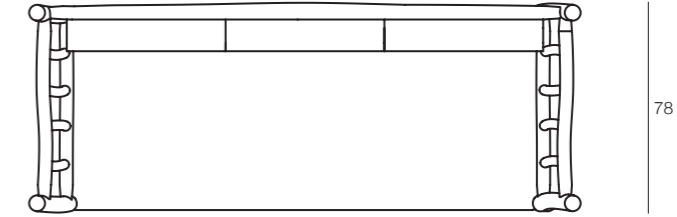
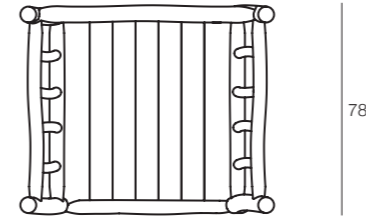
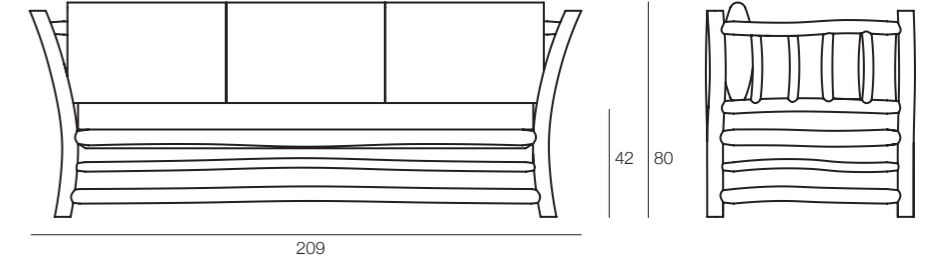

SERE0398

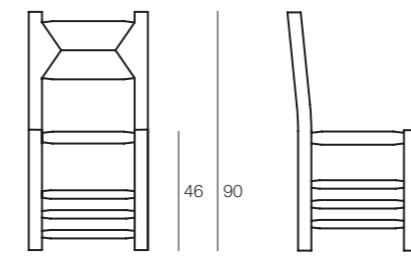

SERE0399

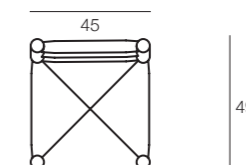
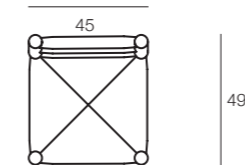
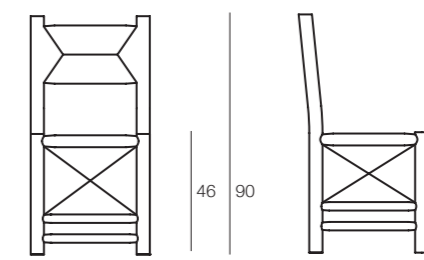

SERE03A1



SERE03A2



SERE03A1

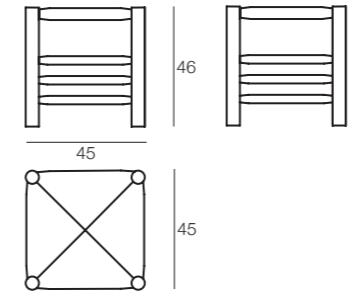

SERE03A2

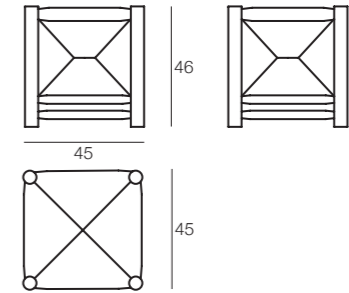

SERE03A3



SERE03A3

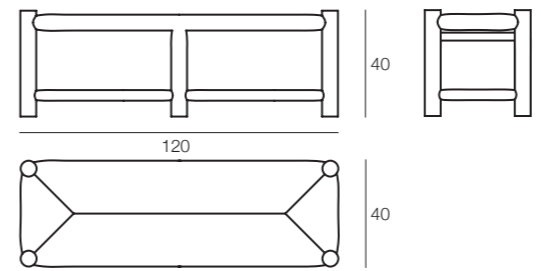

SERE0565



SERE0565

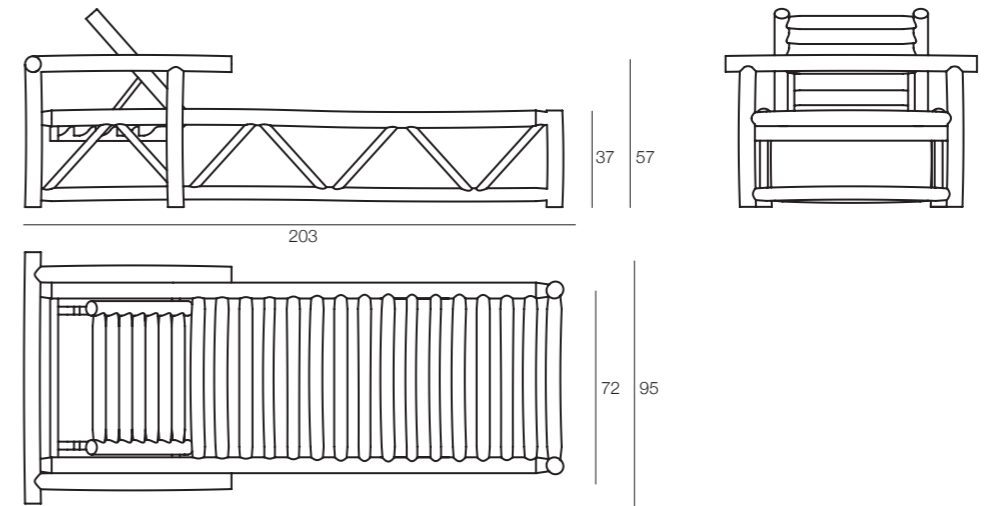

SERE0566



SERE0566

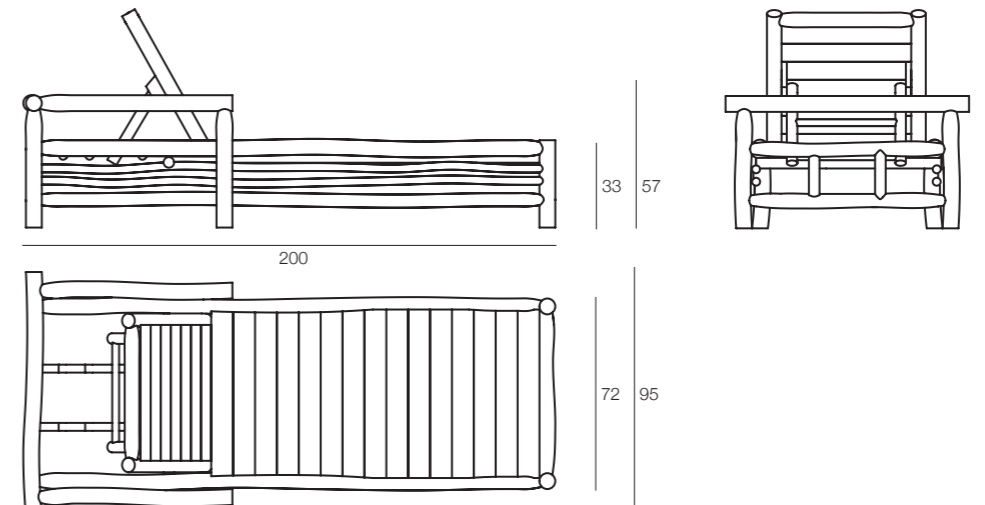

STRATOS

design by design by CAMILLA LAPUCCI E LAPO BIANCHI LUCI

Legno di Teak finitura effetto riciclato antichizzato. Tavolino disponibile con piano in granito lasciato con finitura grezza sul piano e segno della marcatura laterale degli scalpelli. Sedute con cuscino in poliuretano espanso a densità differenziata e dacron, con rivestimento ecru per la versione standard.

La poltroncina da pranzo può essere utilizzata con o senza cuscino dello schienale. Lettino doppio con schienali reclinabili indipendenti. Tavolo da pranzo con lati lunghi irregolari che mettono in evidenza la naturalità del legno.

Teak wood finish with weathered recycled effect. Coffee table available with top in unfinished granite left with raw finish on the top and sign of the lateral marking of the chisels. Seats with cushion in differentiated density polyurethane foam and dacron, with ecru cover for the standard version.

The dining chair can be used with or without back cushion. Double sunbed with independent reclining backs. Dining table with long irregular sides that highlight the naturalness of the wood.

SRTS02B2



SRTS02B2

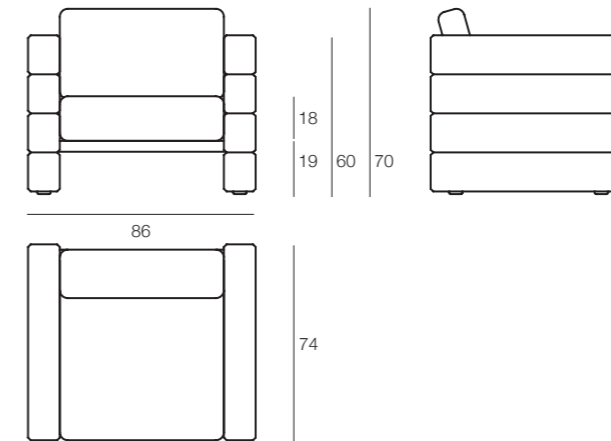

SRTS02B3

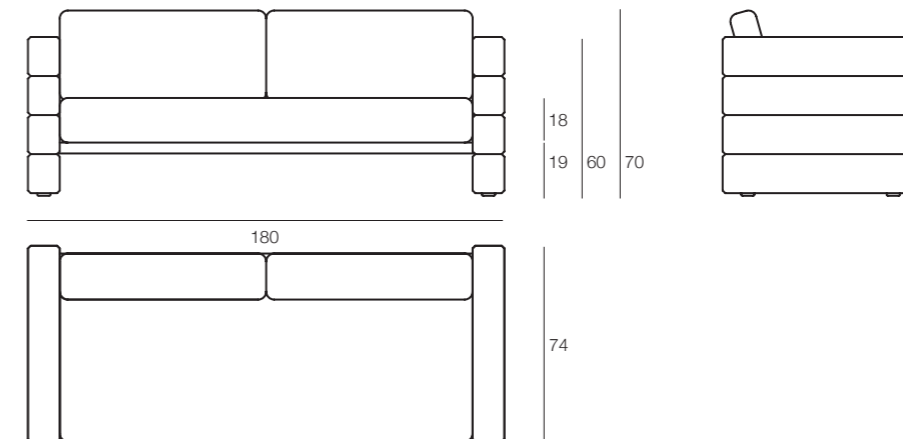

SRTS02B3



SRTS02B4



SRTS02B4

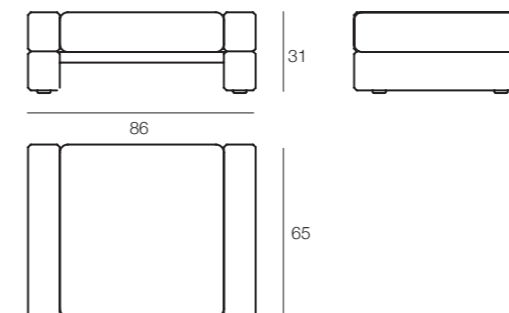

SRTS04H8



SRTS04H8

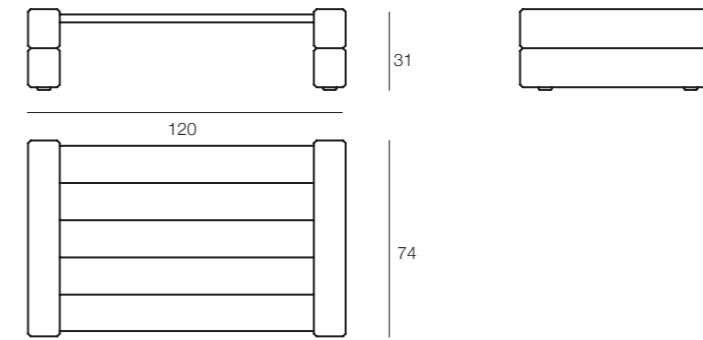

SRTS03B5



SRTS03B5

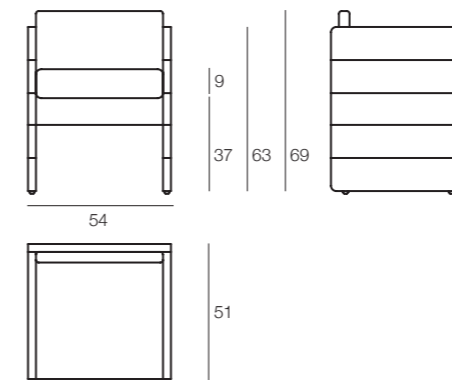

SRTS04I2



SRTS04I2

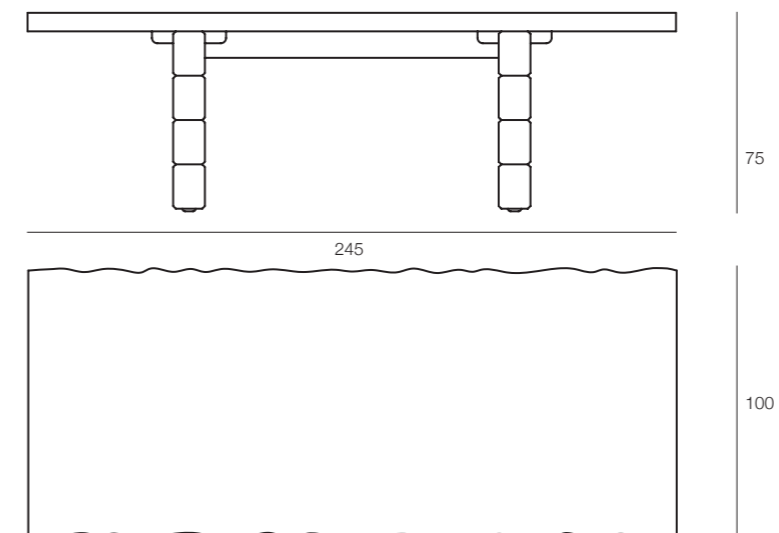

SRTS0577



SRTS0577

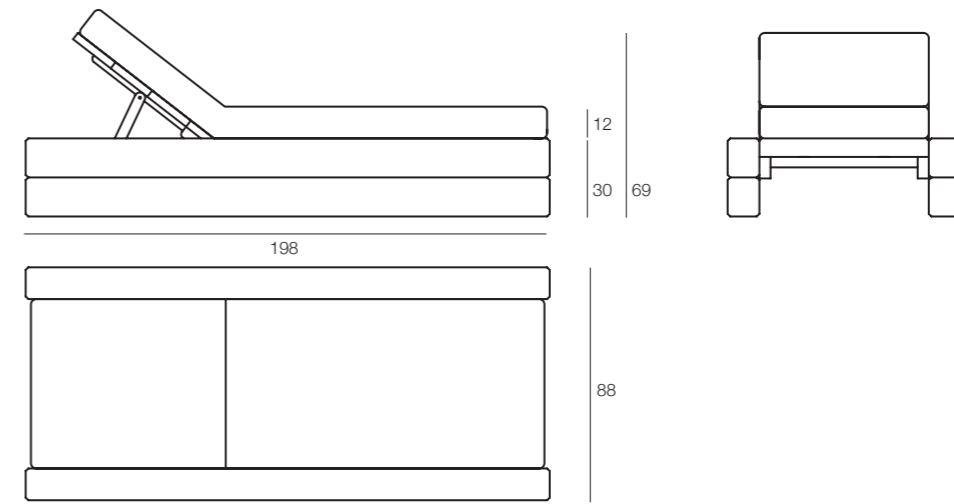

SRTS0578

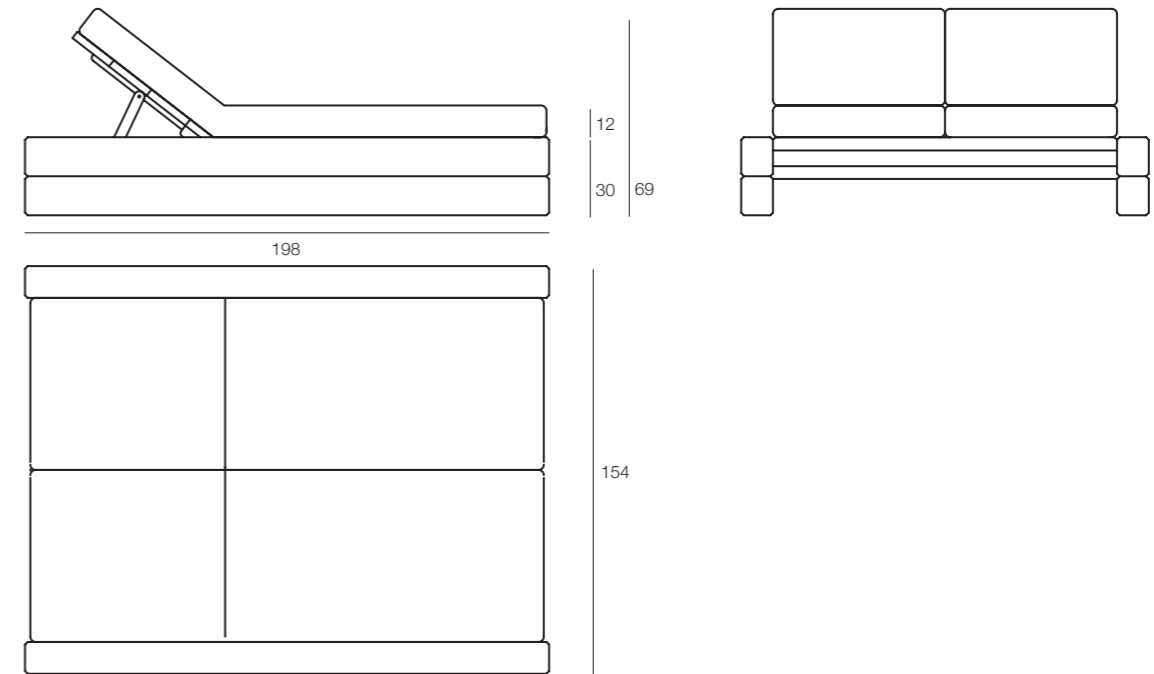

SRTS04H9



SRTS04I1



SRTS04H9

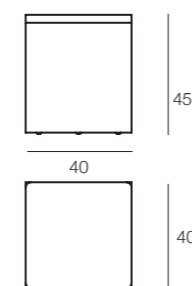

SRTS04I1

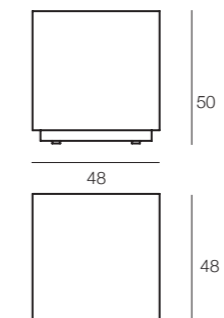

SUAR

ADDENDUM full collection: CATALOGO GENERALE

La collezione Suar esalta gli spessori del legno massello con una struttura slanciata, caratterizzata da braccioli e schienali dai tagli diagonali. La linea comprende panche in tronco, divano e poltrone, letti da esterno, elementi compositivi, tavolini e pouf, oltre a tavoli di grandi dimensioni creati con piani in un unico taglio di legno massello di Suar. La finitura oliata è la finitura standard per questo tipo di legno.

Suar collection enhances the thickness of solid wood with a linear design, featured by diagonal cut armrests and backrests. The collection includes log bench, sofa and lounge chairs, outdoor beds, compositional elements, tables and ottomans, and tables made out of a single slice of solid Suar wood. Oiled finishing.

SUAR0411



SUAR04D8



SUAR04G8



SUAR0407



SUAR0410



SUAR04D7



SUAR04D9



SUAR04G9



SUAR08B3



SUAR0407

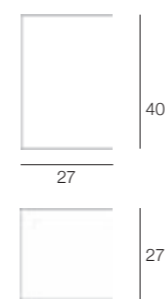

SUAR0410

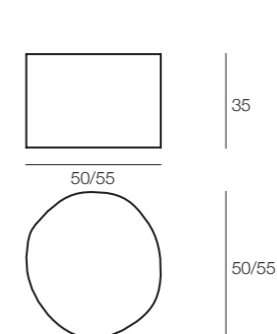

SUAR0411

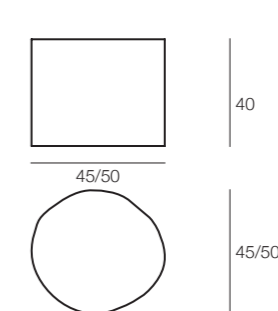

SUAR04D7

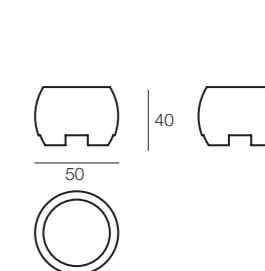

SUAR08B3

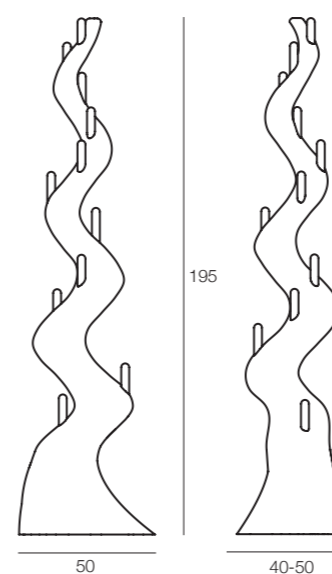

SUAR04D8

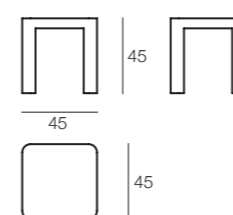

SUAR04D9

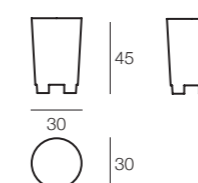

SUAR04G8

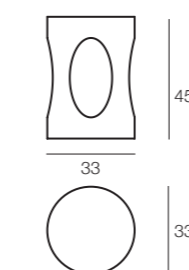

SUAR04G9

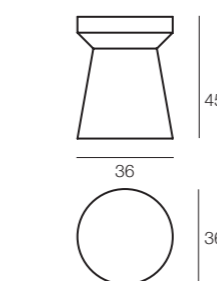

TARA

design by CRS SILAT

Tara è una linea di arredi outdoor che usa il rattan per avvolgere la struttura in legno di teak, esaltando il materiale e rendendolo il vero protagonista di queste sedute da giardino. Le forme sono sempre morbide ed ergonomiche, e alla comodità si aggiunge la struttura interna in teak, una garanzia di robustezza e stabilità, per arredi che avranno bisogno di poca manutenzione per essere sempre al top.

Tara is a line of outdoor furniture that uses rattan to wrap the teak wood structure, enhancing the material and making it the real protagonist of these garden chairs. The shapes are always soft and ergonomic, and the comfort is added to the internal structure in teak, a guarantee of strength and stability, for furniture that will need little maintenance to be always at the top.

TARA0291



TARA0291

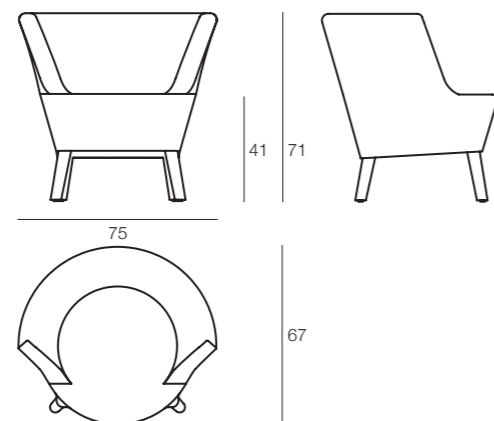

TARA0391



TARA0392



TARA0393



TARA02A2



TARA0391

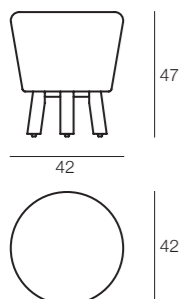

TARA0392

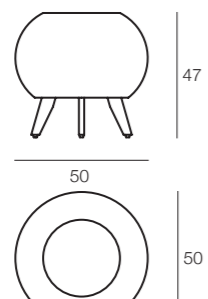

TARA0393

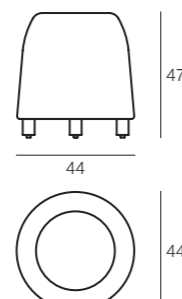

TARA02A2

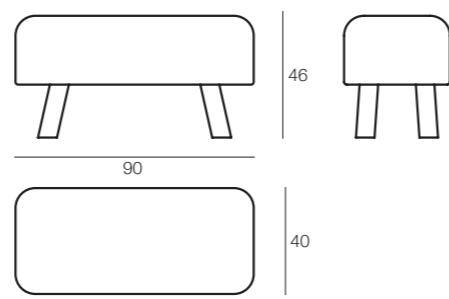

TEA TIME

designed by STUDIO SALARIS

Questa collezione in legno di Suar è declinata in tre tavolini di varia misura che possono essere usati insieme o singolarmente. Il nome deriva dalle piccole maniglie che, come per i vassoi dei più eleganti high tea anglosassoni, sono allo stesso tempo decorative e funzionali. La forma rastremata e raggiata è tornita a partire da un unico blocco di legno. Proposti in Suar finitura oliata.

This Suar wooden collection is available in three tables of various sizes that can be used together or individually. The name comes from the small handles that, as for the trays of the most elegant Anglo-Saxon high tea, are at the same time decorative and functional. The tapered and rounded shape is turned from a single block of wood. Standard finish is oiled wood.



TETI04F8

TETI04F9

TETI04G1



TETI04F8

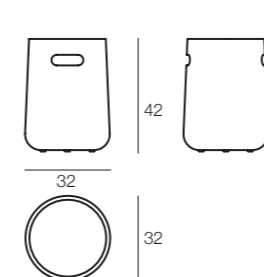

TETI04F9

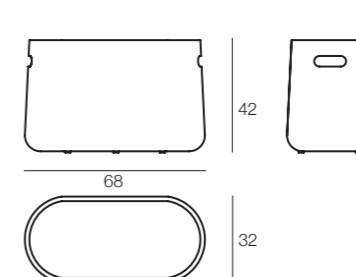

TETI04G1

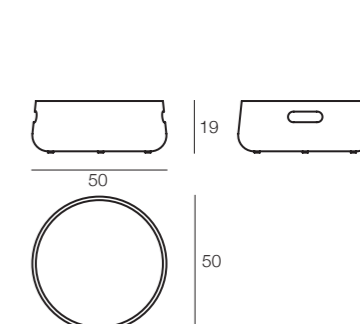

TOUT COURT

design by STUDIO SALARIS

Toutcourt è una collezione dal taglio minimalista, per un arredamento outdoor dal design semplice ed essenziale ma che non rinuncia all'eleganza delle linee e delle forme. La struttura è realizzata in tubolare metallico a doppia sezione - rettangolare e tonda - e l'ampia seduta, confortevole ed accogliente, è in corda completamente intrecciata a mano.

Toutcourt is a collection with a minimalist cut, for an outdoor furniture with a simple and essential design but that does not renounce the elegance of the lines and shapes. The structure is made of tubular metal with double section - rectangular and round - and the large seat, comfortable and cozy, is completely in handwoven rope. Made of powder coated metal and rope.

TOUT0561

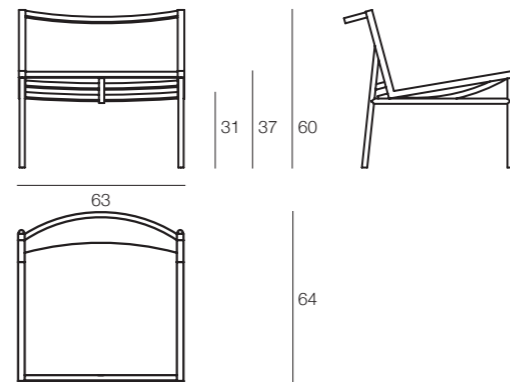

TOUT0562

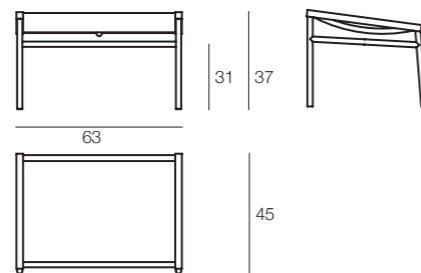

TOUT0561



TOUT0562

WAIKIKI

design by CRS SILAT

Realizzata in fibra sintetica HDPE Peel da 6mm in colore Natural intrecciata su una solida e leggera struttura in alluminio vergine. Piedini dotati di elemento antigraffio in Teflon.

Made of 6mm HDPE Peel synthetic fibre woven on a light but strong virgin aluminium frame. Antiscratch Teflon feet. Synthetic fibre is in Natural colour.

WAIK0569

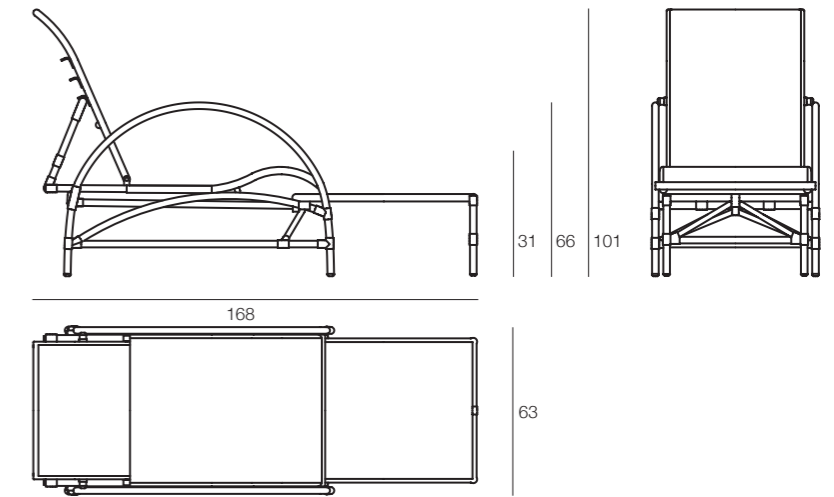

WAIK0569



VENEZIA

ADDENDUM full collection: CATALOGO GENERALE

Ad eccezione dei divani l'intera collezione è costituita da elementi pieghevoli caratterizzati da ingombri minimi quando chiusi. Le sedie regista sono in legno di Teak con seduta e schienale in tessuto Ecrù, così come la tela della sedia tripolina che può essere richiesta in versione normale a strato singolo oppure con imbottitura. Ferramenta in acciaio ed ottone cromato. Il legno è proposto in finitura a levigatura fine naturale.

The shape of canvas can be chosen from single layer or padding. Except the sofas, the whole collection is entirely composed of collapsible elements taking up very small space when folded. The director's chairs and Tripolina deck chair have wooden structure with seat and back in ecru fabrics. Hardware in stainless steel and chromed brass. The standard finishing for the Teak is Fine Sanded.

VENE0346 + K01



VENE0346

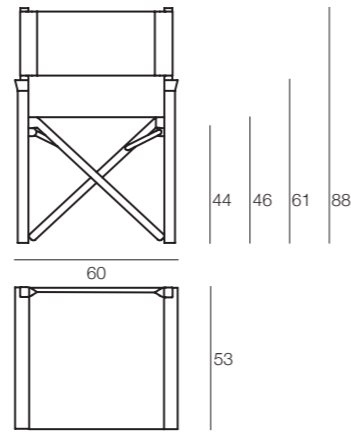

VENE0389



VENE0389

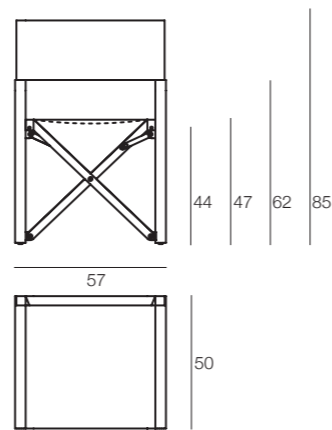

VENE03B1



VENE03B1

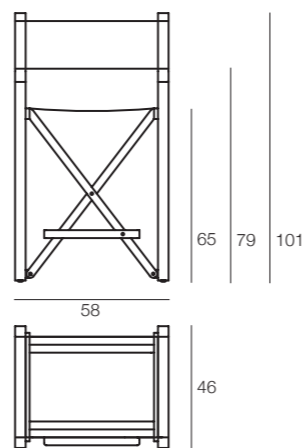

VENE0548



VENE0548

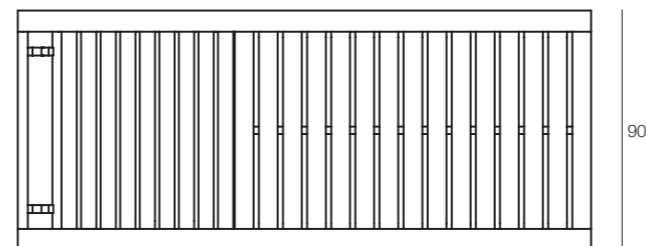
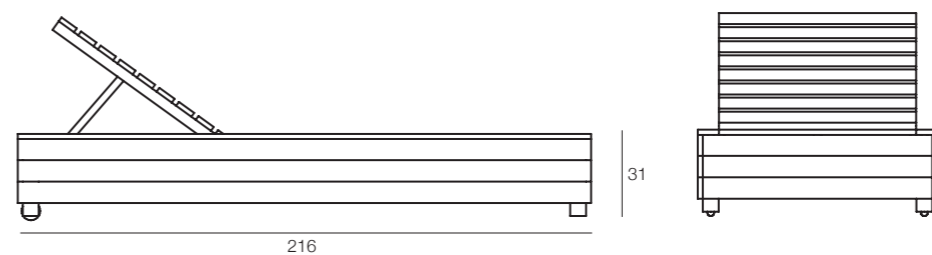

VENE04E7



VENE0452



VENE0453



VENE0454



VENE0455



VENE04E7

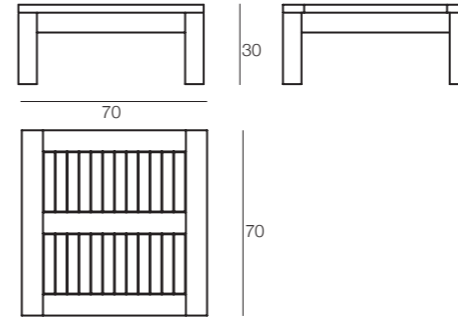

VENE0452

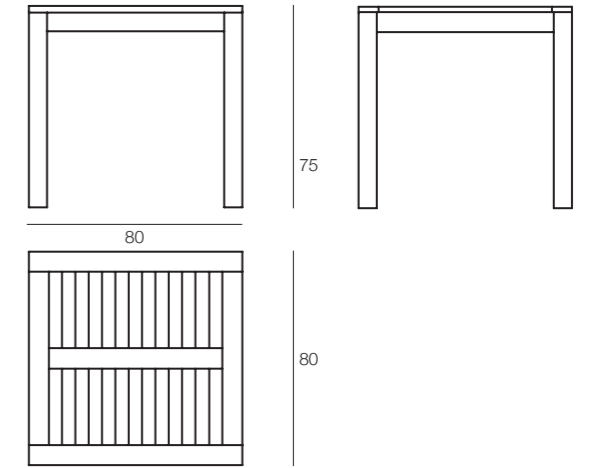

VENE0453

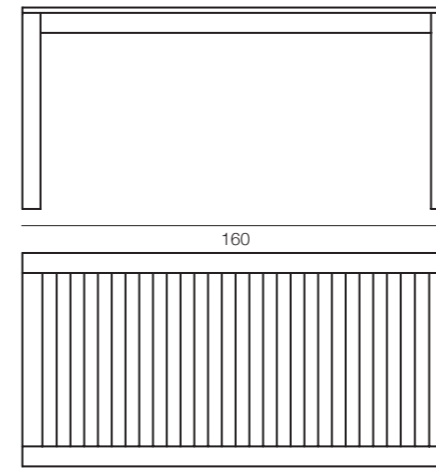

VENE0454

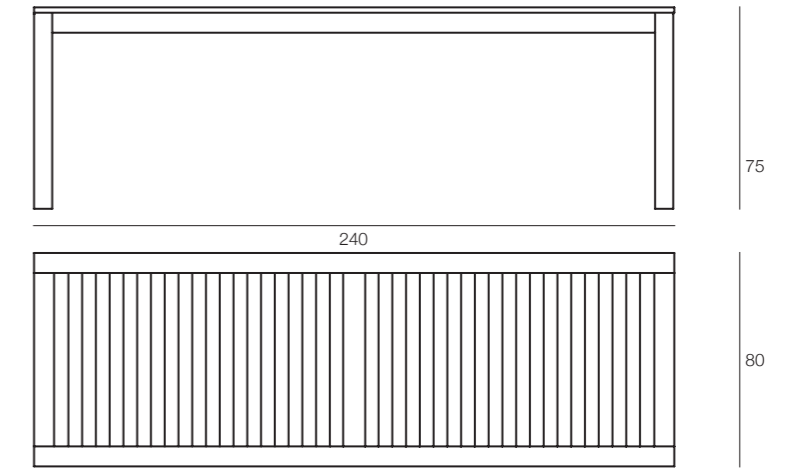

VENE0455

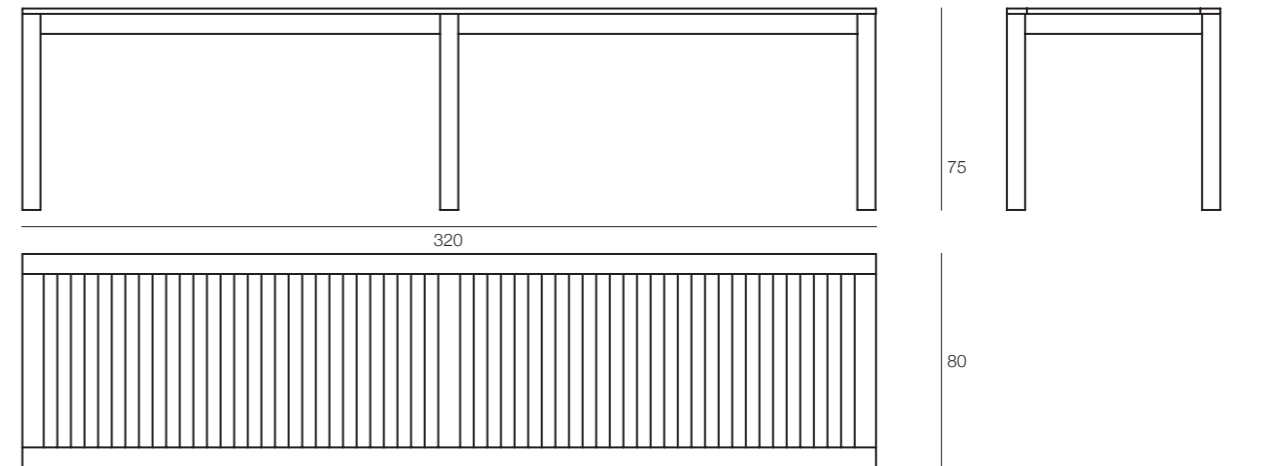

WALLY

designed by CRS SILAT

La collezione Wally si distingue dalle altre per la particolare finitura del legno grezzo: l'effetto della lavorazione da' così un'aria vissuta e "vintage" a tutta la linea. Wally offre ogni tipo di arredo: tavoli, panche e sedute di varie tipologie, oltre a una linea di taglieri che completano perfettamente il set, permettendo così la totale personalizzazione dell'arredo del proprio ambiente outdoor.

The Wally collection stands out from the others for the particular finish of the raw wood: the effect of the workmanship gives a lived and "vintage" air to the whole line. Wally offers any type of furniture: tables, benches and seats of various types, as well as a line of cutting boards that perfectly complement the set, allowing total customization of the furniture of your outdoor space.

WALL0295



WALL0296



WALL0295

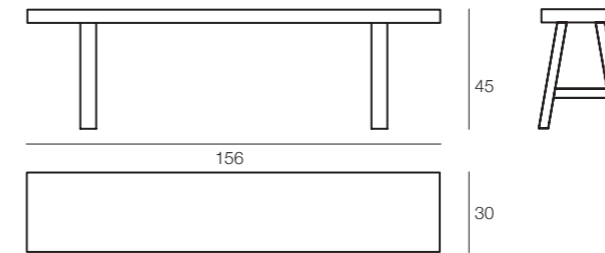

WALL0296

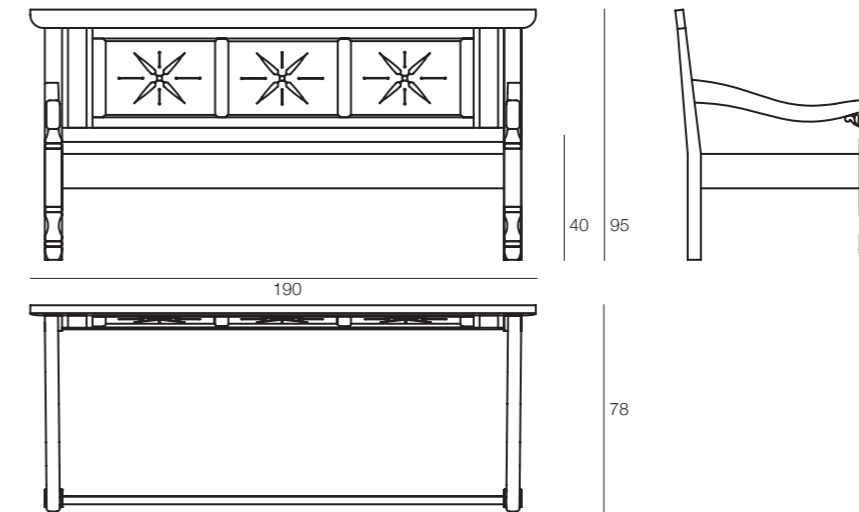

WALL0395



WALL0396



WALL0397



WALL0395

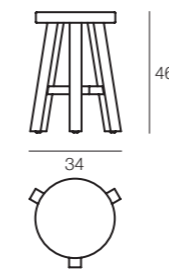

WALL0396

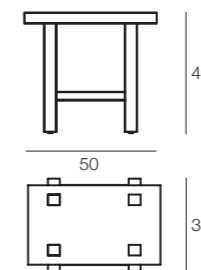

WALL0397

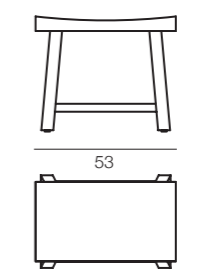

WALL08A8



WALL08A9



WALL08B1



WALL08B2



WALL08A8

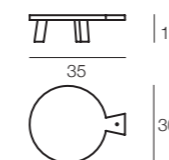

WALL08A9

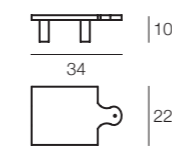

WALL08B1

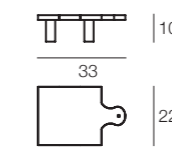

WALL08B2

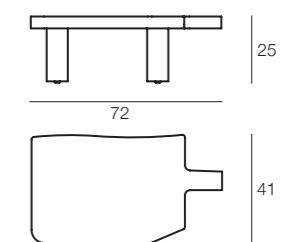

WALL04E8



WALL04E8

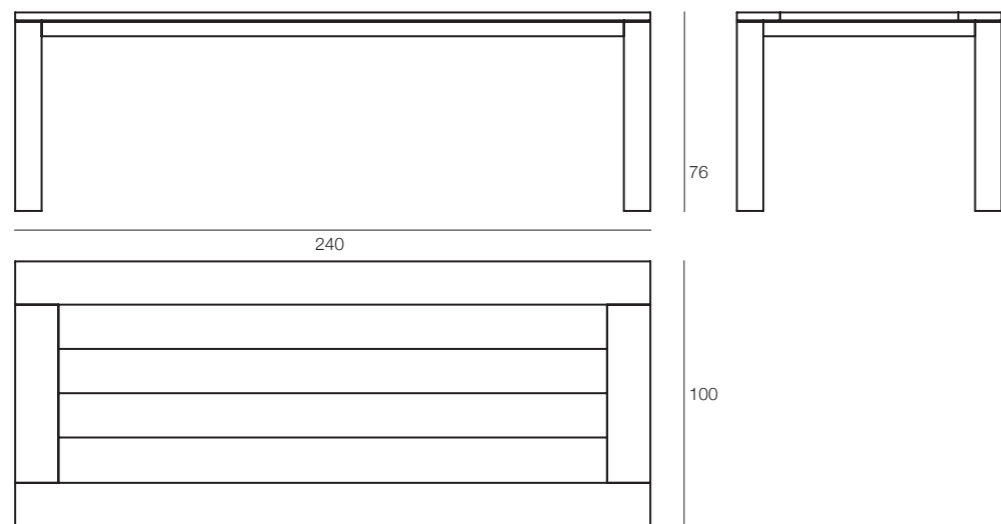

OMBRELLONI

Durability, comfort and strenght

Struttura a palo centrale, disponibile in legno o in metallo. Dimensioni personalizzabili. Basi in metallo, cemento o marmo. Possibilità di fissaggio diretto a terra. Su richiesta disponibili accessori per il riscaldamento, il raffrescamento, l'illuminazione, la cablatura o le canaline. Copertura in tessuto acrilico o in tessuto tecnico microforato oppure in fibra ETFE impermeabile.

Structure with central pole, available in wood or metal. Customisable dimensions. Metal, cement or marble bases. It can be fixed directly in the ground. Heating, cooling, lighting accessories, wiring or cable ducts available on request. Acrylic fabric or microperforated technical fabric or waterproof ETFE fibre cover.

ZOCW2500



ZOCW2500

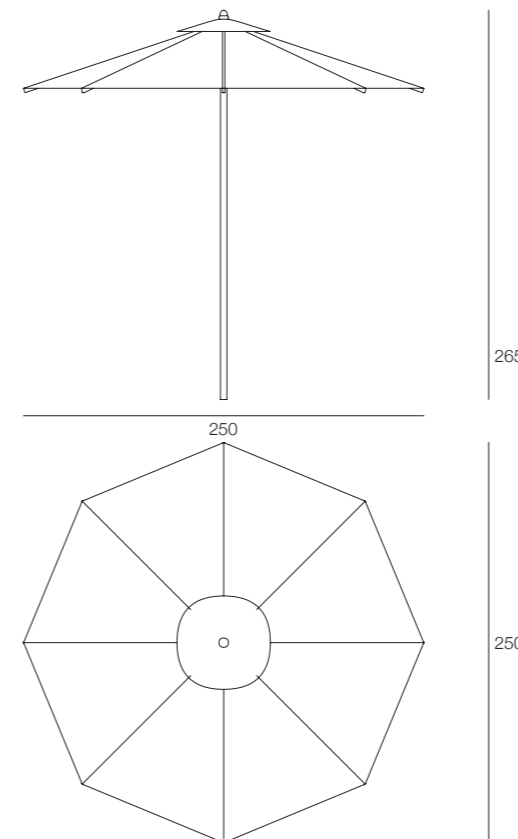

ZPIS0322



ZPIS0322

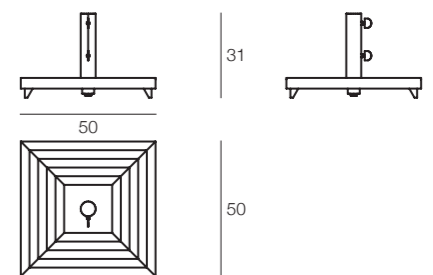

ACCESSORI

full collection: CATALOGO GENERALE

Accessori e complementi in Teak o in fibra sintetica intrecciata su struttura in alluminio. Dettagli in acciaio e piedini antigraffio su molti degli elementi proposti. Interni in zinco disponibili su richiesta per i portavasi. La finitura standard degli accessori è levigatura fine per il Teak e White Wash foc 6mm per la fibra sintetica intrecciata.

Accessories and complements in Teak wood or synthetic fibre woven on aluminium frame. Many of the elements proposed feature steel accents and anti-scratch feet. Zinc interior available on request for plant pot holders. The standard finishing is Fine Sanded Teak wood and White Wash foc synthetic fibre.

SRI00209



SRI00210



SRI00212-SRI00213-SRI00214



SRI00219



SRI00209

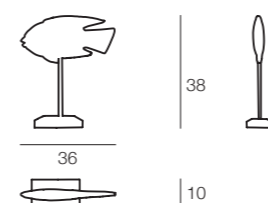

SRI00210



SRI00212

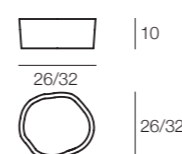

SRI00213

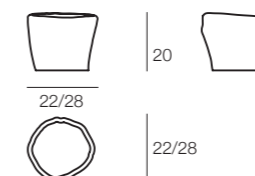

SRI00214

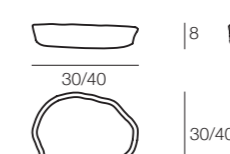

SRI00219

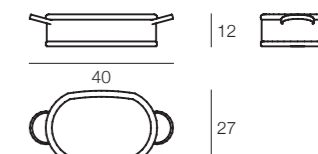

SRI00222



SRI00234



SRI00222

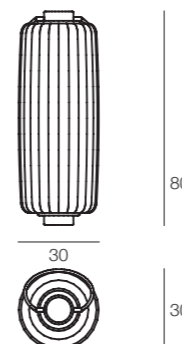

SRI00234

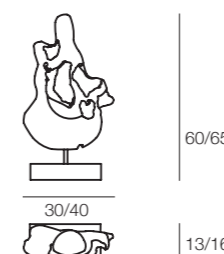

SRI00223

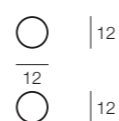

SRI00224

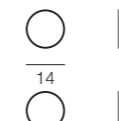

SRI00225

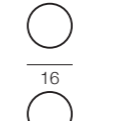

SRI00226

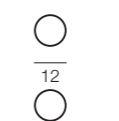

SRI00227

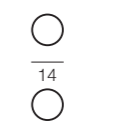

SRI00228

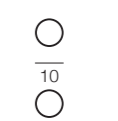

SRI00229

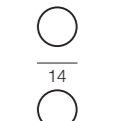

SRI00230 - SRI00231 - SRI00232 - SRI00233



SRI00230

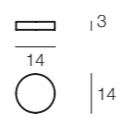

SRI00231

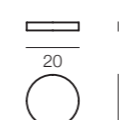

SRI00232

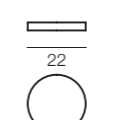

SRI00233

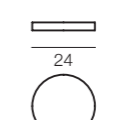

SRI00224 - SRI00225
SRI00223



SRI00226 - SRI00227



SRI00228 - SRI00229



SRI00246



SRI00247



SRI00248



SRI00249



SRI00250



SRI00246

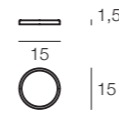

SRI00247

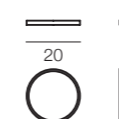

SRI00248

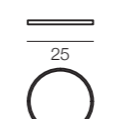

SRI00249

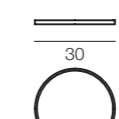

SRI00250

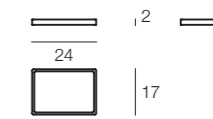

SRI00265



SRI00267



SRI00268



SRI00265

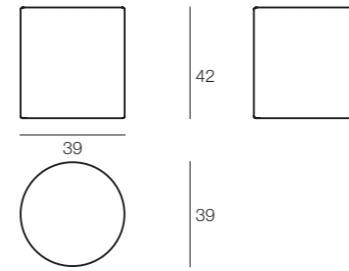

SRI00267

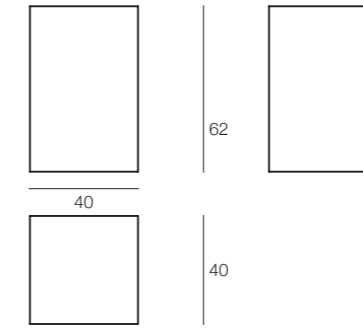

SRI00268

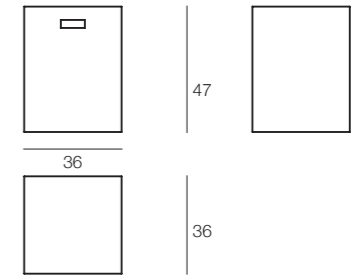

SRI00270



SRI00271



SRI00270

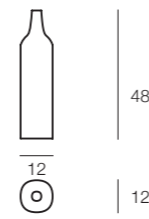

SRI00271

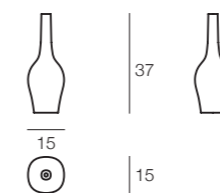

SRI00285

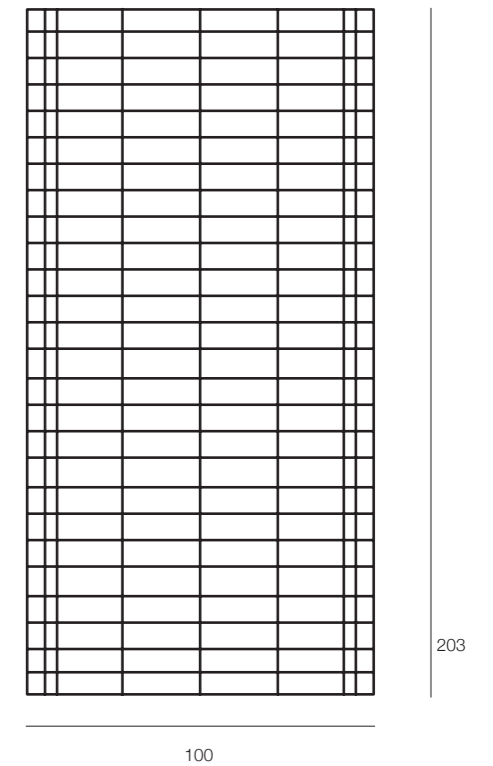

SRI00285



SRI00272



SRI00273



SRI00274



SRI00272-275

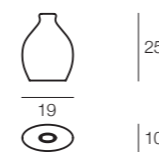

SRI00273-276



SRI00274-277

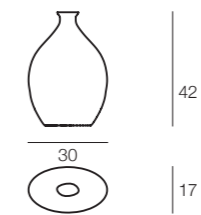

SRI00281



SRI00288



SRI00289



SRI00290



SRI00281

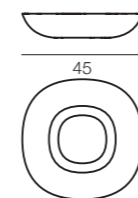

SRI00288

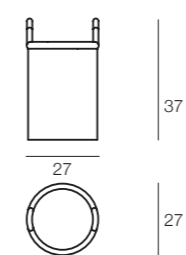

SRI00289

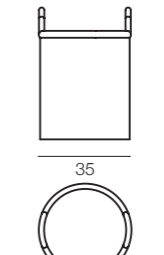

SRI00290

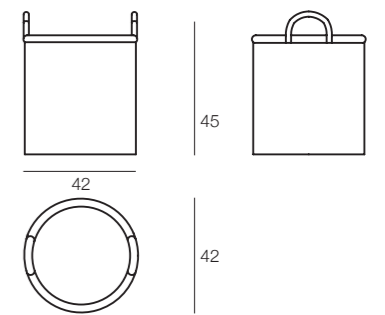

SRI00291



SRI00291

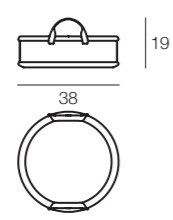

SRI00292



SRI00292

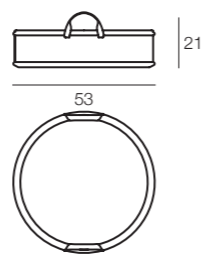

ACCT0810

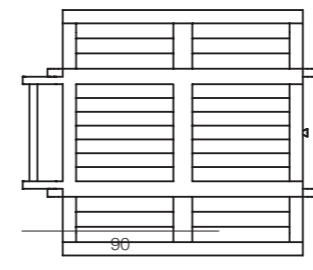
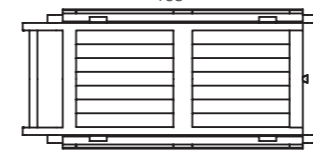
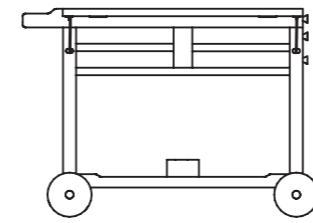

90

78

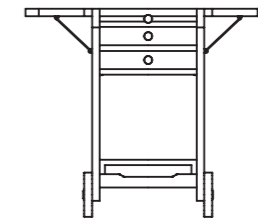
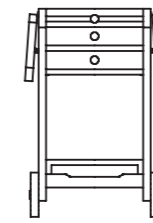

52

ACCT0810

ACCT0810

92



SRI00293



SRI00294



SRI00295



SRI00296



SRI00297



SRI00298



SRI00299



ACCP0824



ACCP0824



45

45

SRI00300



SRI00301



SRI00302



SRI00303



IKAT PILLOWS - Traditional ikat tenun fabrics with outdoor treatment



TILES

design by CRS SILAT

Pavimentazione a quadrotti in legno di Teak. Disponibili nella misura 30x30cm con base in PVC ed incastro maschio-femmina che mantiene le piastrelle solidali tra loro. Oppure nella misura 50x50cm con base in Teak. Drenanti e di facile posa: possono essere appoggiati direttamente sulla pavimentazione esistente, su un battuto di cemento o direttamente sul terreno. I pavimenti sono realizzati con legno di Teak che proviene dai resti di taglio della lavorazione dei mobili da esterno. Quindi nessun albero è stato abbattuto per la realizzazione di questi pavimenti: belli, durevoli, originali e del tutto eco-compatibili. Il legno è proposto in finitura a levigatura fine naturale.

Teak flooring tiles. Available in 30x30cm size with PVC backing and male-female interlock which ensures that the tiles perfectly fit together. Or in 50x50cm size with Teak backing. Water runoff and easy to lay: can be laid directly on existing flooring or on a cement slab or even directly on the ground. Tiles for flooring are made of Teak wood coming from the cut wastage of the outdoor furniture production, so that no trees were cut for the construction of these beautiful, durable, original and completely eco-friendly floors. Fine Sanded is the standard wood finishing.

TILT2502



50 x 50 cm

TILT2501



50 x 50 cm

TILT2301



TILT2303



30 x 30 cm

COLLECTIONS

ALICE:	p 82	PALEOLITICA:	p 124
ANTIPODI:	p 84	PENINSULA:	p 126
BISTROT:	p 90	PHOEBE:	p 130
BERBEDA:	p 91	RADICE:	p 131
CAPRICCIO:	p 92	REMIX:	p 132
CLASSICA:	p 98	RING:	p 134
CHARPAI:	p 100	SAINT RAPHAEL:	p 136
CODE:	p 104	SAVANA:	p 137
CORDA:	p 106	SERENGETI:	p 138
DESIRE:	p 108	STRATOS:	p 142
EMILY:	p 110	SUAR:	p 148
FAMIGLIA:	p 111	TARA:	p 150
GIPSY:	p 112	TEA TIME:	p 151
JENGA:	p 114	TOUT COURT:	p 152
KARENITA:	p 115	VENEZIA:	p 154
KROSS:	p 116	WAIKIKI:	p 153
MACRAME':	p 118	WALLY:	p 158
NANTO:	p 122	TILES:	p 168
OMBRELLONI:	p 161		

MORE

DESIGNERS:	p 170	FINISHING:	p 172-174
ACCESSORI:	p 162	MAINTENANCE:	p 173

CAMILLA LAPUCCI LAPO BIANCHI LUCI



Camilla Lapucci e Lapo Bianchi Luci, l'uno architetto e l'altro designer, lavorano insieme dal 2002 esplorando differenti territori che spaziano dall'architettura all'interior design, dalla direzione artistica al graphic design.

Le differenti singole precedenti esperienze in prestigiosi studi di Architettura di Firenze sono confluite in un percorso comune che ha poi permesso di iniziare un'intensa collaborazione con il mondo dell'interior design e del wellness, occupandosi di progetti di architettura e di interni a livello nazionale ed internazionale, coprendo diversi settori.

Ogni progetto è concepito attraverso un'accurata scelta di materiali e di superfici, di volumi, di pieni e di vuoti in reciproca relazione.

Nel settore delle SPA hanno ricevuto diversi riconoscimenti e premi tra cui il premio del Gran Prix Casalgrande e la menzione speciale al Wellness Design Awards.

Camilla Lapucci and Lapo Bianchi Luci, the first architect and the other designer, have been working together since 2002 to explore different areas, ranging from architecture to interior design, from art direction to graphic design.

The different individual previous experience in prestigious Architecture firms in Florence have merged into a common path that has allowed them to begin an intense collaboration with the world of interior design and wellness dealing with architectural and interior design projects at national and international levels.

Each project is conceived through a careful choice of materials and surfaces, volumes, solids and voids in a mutual relationship.

Concerning the SPA projects, they have received several awards and prizes, including the 1st prize in the Grand Prix Casalgrande in 2007 and a special mention at the Wellness Design Awards 2008.



STUDIO SALARIS

Studio Salaris nasce a Milano città del design, nel cuore del centro storico di Brera.

A fondarlo è Alessandra Salaris che, dopo gli studi classici, si dedica all'interior design presso lo IED, a Londra e al Politecnico di Milano dove consegue la Laurea. Diverse sono le esperienze di lavoro in Italia e all'estero. Un master in comunicazione e marketing si rende indispensabile per meglio capire le dinamiche aziendali con le quali intende confrontarsi professionalmente.

Con esperienza più che decennale si confronta con le più importanti riviste e aziende, famose a livello sia nazionale che internazionale. La volontà è di offrire un supporto individuale e fortemente personalizzato aiutando i clienti ad esplicitare esteticamente, nella forma migliore, la loro intrinseca identità aziendale.

La *mission* è dare un contributo personale e riconoscibile che non sovrasti la vera anima e la storia delle aziende cliente.

Studio Salaris was born in the historic centre of Milan, capital of design.

Founder Alessandra Salaris topped her classical education with the study of interior design in London and Milan, where she attended IED and graduated from Politecnico di Milano. She later earned a Masters degree in Marketing and Communication to better understand the challenges of the business she faces everyday. As of today, she has worked internationally.

In the past decade she has collaborated with the top magazines and companies of the industry.

Her ambition has always been that of delivering a customized support to help her clients achieve an aesthetic expression of their brands.

Her *mission* is to give a personal and recognizable contribution that enhances the clients' story and core values.

FINITURE

Tutti i manufatti lignei vengono prodotti con legno certificato e sottoposto a rigorosi controlli sia interni che da parte delle autorità competenti, lungo tutto il processo produttivo dalla piantagione alla consegna, secondo la rigida normativa europea FLEGT. Il legno utilizzato è legno di Teak della migliore qualità, disponibile nelle finiture 'Fine Sanded', ossia levigatura fine, 'Oil & Wax' eseguita con olio e cera, 'Java Brown' caratterizzata dalla pigmentazione scura color testa di moro, 'White Wash' e 'White Sand' dall'effetto decapato.

Per le collezioni Jenga, Phoebe, Suar viene usato legno massiccio tropicale di Suar. Proposto con levigatura grezza e finitura ad olio.

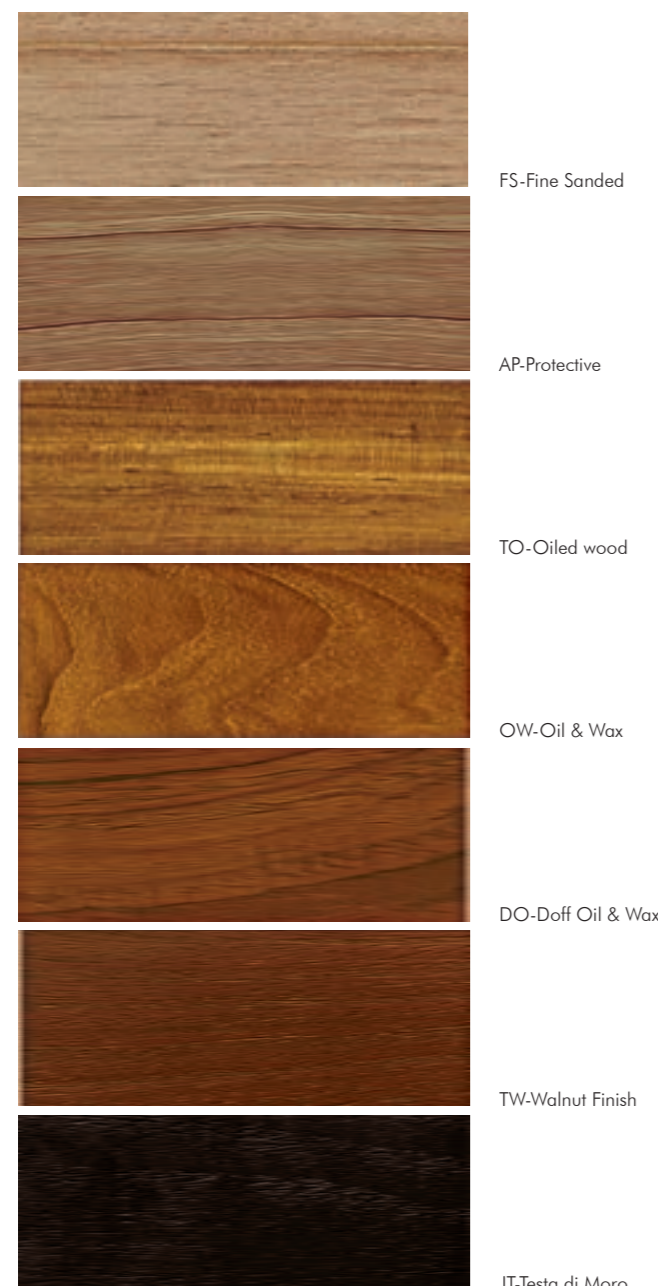

FINISHING

All the wooden manufactured products are made of certified wood accurately controlled both by our staff and by the competent authorities during the entire production, from plantation to delivery, in compliance with the FLEGT strict European regulations

Wooden collections are made with the best quality teak wood available in different finishes: 'Fine Sanded', 'Oil & Wax', 'Java Brown' characterized by dark brown pigmentation, 'White Wash' and 'White Sand' with pickled effect.

Items of Jenga, Phoebe and Suar collections are made of Suar tropical hardwood with raw sanding and oil finish.

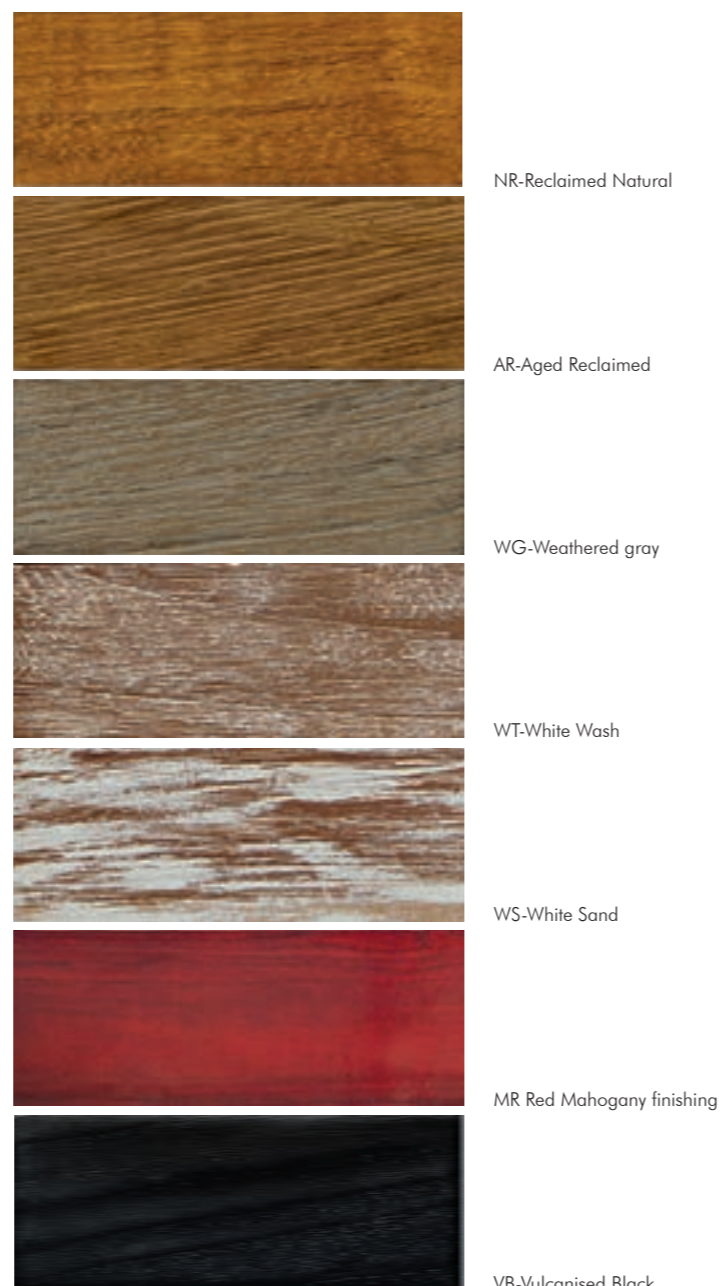

MAINTENANCE

Il legno è un materiale 'vivo' che, in relazione al luogo in cui viene posizionato, può richiedere una particolare manutenzione. Con l'applicazione dell'olio e della cera, il Teak risulterà perfettamente protetto e ravvivato nel colore. L'olio per Teak può essere usato su legno grezzo come unico e completo agente protettivo, oppure su legno già trattato, purchè preventivamente pulito, come prodotto per la manutenzione. La cera fornisce uno strato protettivo ulteriore, pressoché invisibile, che riduce la penetrazione di macchie di oli e liquidi sulla superficie del legno. Si tratta di una cera in pasta di colorazione neutra, costituita da una miscela di elementi naturali selezionati tra cui cera d'api, cera carnauba ed essenza di trementina. I kit di manutenzione de Il Giardino di Legno sono ideali per lucidare e proteggere i mobili e gli oggetti in legno di Teak.

Wood is a "living" material which, depending on where it is placed, can require a particular maintenance. The Teak wood will result perfectly protected and brightened up the colour applying oil and wax. The oil for teakwood can be used on raw wood as single and complete protective agent or on already treated wood, provided that it has been cleaned before, as maintenance product. The wax provides a further protective layer, almost invisible, avoiding the food, oil and liquid stains to seep through the wood surface. It consists of a colourless wax paste, made of a mix of selected natural elements among which beeswax, carnauba wax and turpentine gum. The maintenance kits by Il Giardino di Legno are suitable to polish and protect teakwood furniture and objects.

MAIN2001



MAIN2002

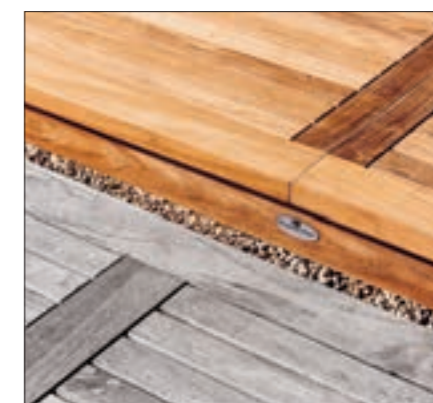

MAIN2003



MAIN2004



MAIN2005



FINITURE

L'acciaio inossidabile è una lega ferrosa che, grazie al contenuto di nichel e cromo, è molto resistente alla corrosione. L'alluminio viene utilizzato per creare le strutture interne dei mobili in rattan: preventivamente trattato e verniciato per una migliore protezione agli agenti atmosferici, viene successivamente utilizzato come supporto per l'intreccio della fibra sintetica. Per l'uso esposto vengono utilizzati tubolari di alluminio vergine oppure acciaio dolce sottoposti a bagni di pulitura e verniciati a polvere.

Per gli intrecciati sono impiegate fibre sintetiche a base polietilenica che hanno qualità uniche di resistenza ai raggi UV, di riciclabilità e di resistenza agli sbalzi di temperatura. Inoltre non necessitano di manutenzione e sono insensibili a funghi e parassiti.

Per gli arredi della collezione Antipodi viene usata una struttura in metallo con finitura a polveri nera opaca ruvida e corda talpa 5 mm tonda.

La corda utilizzata negli intrecci è una corda in polipropilene o in acrilico, da molto utilizzata nel campo nautico, presenta un'alta resistenza all'abrasione ed ai raggi UV mantenendo un carico di rottura molto alto che la rende idonea alla produzione di arredi esterni di altissima qualità anche per uso contract.

Agli articoli in fibra naturale viene applicata una finitura trasparente protettiva. E' comunque sconsigliato l'uso all'esterno non coperto.

I piani in vetro hanno differenti bordature a seconda del modello e sono disponibili trasparenti, satinati, o fumè.

Il Batyline® è un tessuto che combina l'eleganza delle fibre naturali con la performance del tessile industriale.

Gli imbottiti standard sono in poliuretano a densità differenziata, disponibili su richiesta imbottiture drenanti o a cella piena. I tessuti standard a rivestimento della cuscineria sono in acrilico colore ecrù.

Su richiesta possono essere usati tessuti colorati Sunbrella® o di altro tipo a scelta del Cliente.

FINISHING

The stainless steel is a ferrous alloy that, thanks to nickel and chromium, is highly corrosion-resistant. Aluminium is used for the internal frames of the rattan furniture. It is previously treated and painted to better resist to weather conditions and then used to bear the synthetic fiber weave. Cleansed and powder coated tubular virgin aluminium or steel structures are employed for an exposed use.

The polyethylenic based synthetic fibers used for the woven collections have unique UV ray resistant qualities, can be recycled and boast a good resistance to changes in temperature. Moreover they do not need any maintenance and are insensitive to fungus and parasites.

Items of Antipodi collections are made of black powder coated metal and cord grey color 5 mm.

The ropes used for the weaving are specific for outdoor use and made from a synthetic material (Acrylics or polypropylene) that is highly resistant to UV rays, abrasion and has a really high broken point. These will ensure an extremely functional and comfortable woven seat and backs ideal for high quality outdoor furniture also in a contract environment.

Natural fibers items are protected by a transparent, semi-glossy finishing. It is anyway suggested not using it in an uncovered outdoor space.

The glass tops have different edges according to the model and are available in transparent, satin or smoke-grey version.

The technical fabric Batyline® combines the elegance of the natural fibers to the performance of the industrial fabric.

The standard upholstered are made of low/high density polyurethane foam or flow-through foam on customer's request.

On customer request can be used coloured Sunbrella® fabrics or other brands.



RN Natural Rattan

RG Natural Rattan Grey colour



TC Cord Talp 12 mm flat

GC Cord Grey Colour



BIFB Black and Ice White rattan fishbone weaving

NA15 Rattan Natural 15 mm

CS Rattan Cognac colour



DC Cord Dove 6 mm round

HC Cord Brown mixed



RW Rattan White

RN Natural Rattan

RT Transparent finish Rattan

RN Natural Rattan



SC Cord Smoke Gray

KC Cord Khaki Colour



BH Single Rope Hyacinth (big)



TH Double Twisted Hyacinth RH Single Rope Hyacinth

