

Collections Catalogue 2023

copiosa
seating for design lovers

seating
for design
lovers



copiosa
seating for design lovers

La nostra anima è un punto fermo. Da sempre promuoviamo i valori del Made in Italy e della lunga tradizione manifatturiera del distretto della sedia. Nel 2021 il brand Copiosa propone una nuova veste: ha inizio un nuovo capitolo in cui la tradizione si fonde con la contemporaneità.

Attraverso una sintesi di artigianato e industria, esperienza, conoscenza del mercato e innovazione, realizziamo prodotti che parlano a tutti con un linguaggio universale.

La collezione Copiosa è ricca, varia, aperta per vocazione, desiderabile e raggiungibile da un pubblico vasto e multiforme. Con sguardo lungimirante, attraverso la selezione di materiali e processi produttivi, ci impegnamo a perseguire uno sviluppo attento all'ambiente, per un brand sostenibile.

I principi che ci hanno fatto crescere sedimentano, si uniscono a nuove riflessioni e confluiscono in un nuovo immaginario visivo che oggi rende Copiosa iconica, pop, fruibile, sostenibile.

Our soul is a fixed point. We have always embodied Made in Italy values and the long manufacturing tradition of the local chair district.

In 2021 Copiosa reveals its new look:

a fresh chapter begins in which tradition merges with all that is contemporary.

Through a synthesis of craftsmanship and industry, experience, market knowledge and innovation, we make products that speak to everyone through a universal language. The Copiosa collection is rich, varied, open by vocation, desirable and attainable by a vast and diverse public. Forward-thinking, through the selection of materials and production processes, we are committed to pursuing environmentally friendly development for a sustainable brand. The principles that have made us grow keep piling up, combining with new reflections to flow into a whole new look that today makes Copiosa iconic, pop, functional, sustainable.

Famiglie Families

Sedute, sgabelli, poltroncine, tavoli: Copiosa è un insieme ricco e articolato di famiglie, capaci di integrarsi con naturalezza nei contesti quotidiani. Prodotti versatili e infinite combinazioni di colori, materiali e finiture, che interpretano gli spazi nel tempo, proponendo soluzioni innovative per il lavoro e il vivere contemporaneo.

Chairs, barstools, armchairs, tables: Copiosa is a rich and complete set of families, each able to integrate naturally into everyday contexts. Versatile products and infinite combinations of colours, materials and finishes that interpret spaces over time, proposing innovative solutions for workspaces and contemporary living.



OUTDOOR Families



b. outdoor



0C97



0C99



0C89

serpentine



1C01

centouno



1C10



1C14



1C11



1C16

OPTIONAL CUSHION



galileo



0C01 round



0C02 round



0C03 round



0C04 round



0C01 square



0C02 square



0C03 square



0C04 square

iosa



0C10 square



0C11 square



0C10 round



0C11 round

CORPORATE Families



baby d.



0C17

0C18

0C19

billa



1C50

1C51

button down



7C20

7C22

7C25

7C21

7C23

7C24

bold



0C90

0C92

0C93

0C98

0C94

0C95

0C96

float



0C00

0C01

galileo



0C01 round

0C02 round

0C03 round

0C04 round

0C01 square

0C02 square

0C03 square

0C04 square

iosa



0C10 square

0C11 square

0C10 round

0C11 round

link



0C70

0C71

0C72

marilyn steel



7C40

7C41

7C58

rose steel



0C34

0C35

0C36

0C37

0C39

CORPORATE Families



my chair



1C40

1C41

1C42

serpentine



1C00

spoon



0C80

0C81

0C82

0C83

0C86

0C84

wrap steel



6C70

6C71

6C72

6C74

wround



6C80

6C81

6C82

6C83

COMFORTABLE CONTRACT Families



askew



5C35

5C36

5C37

billa



1C50

1C51

eileen



7C01

7C02

7C03

7C05

kursaal



7C10

7C12

marilyn wood



7C31

7C32

7C36

7C34

miami



4C00

4C01

my chair



1C40

1C41

1C42

spoon



0C80

0C81

0C82

0C83

0C86

0C84

wrap wood



6C60

6C61

6C62

6C63

6C64

6C65

Index

Askew	pag. 16 - 21
Baby D.	pag. 22 - 29
Billa	pag. 30 - 43
Bold	pag. 44 - 55
B. Outdoor	pag. 56 - 65
Button Down	pag. 66 - 75
Centouno	pag. 76 - 85
Eileen	pag. 86 - 93
Float	pag. 94 - 101
Galileo	pag. 102 - 109
Iosa	pag. 110 - 117
Kursaal	pag. 118 - 125
Link	pag. 126 - 133
Marilyn	pag. 134 - 143
Miami	pag. 144 - 151
My Chair	pag. 152 - 161
Rose	pag. 162 - 173
Serpentine	pag. 174 - 183
Spoon	pag. 184 - 193
Wrap	pag. 194 - 205
Wround	pag. 206 - 215
Finiture/Finishes	pag. 216 - 219



Askew

design Daniel Fintzi

Cornici scolpite e sinuose sorreggono cuscini dalle proporzioni geometriche: attraverso un equilibrio di elementi, Askew rende omaggio alle forme scultoree di epoca classica. Declinata nelle varianti poltroncina, poltrona e divanetto in massello di faggio, con rivestimento in tessuto, pelle o ecopelle, la collezione si propone come un esempio di classico-contemporaneo.

Geometric cushions are supported by sinewy and sculptured frames: through its perfectly balanced elements, Askew pays homage to sculptural figures of the Classical Age. Declined in armchair, lounge chair and two-seater sofa, in solid beech, with fabric, leather or eco-leather upholstery, the collection is an expression of contemporary-classic style.





copiosa

SEATING FOR CONTRACT

Askew

design Daniel Fintzi

Poltroncina, poltrona e divanetto in massello di faggio tinto o laccato, con rivestimento in tessuto, pelle o ecopelle.

Seat collection with stained or lacquered beechwood frame, with fabric, leather or eco-leather upholstery.

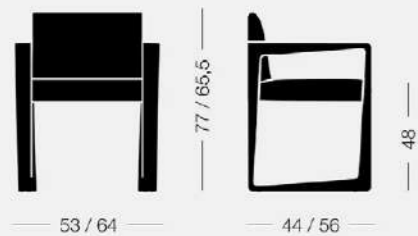

Askew 5C35 10,9 kg 0,30 m³ 1 pz

Poltroncina, struttura in legno
Armchair, wood frame

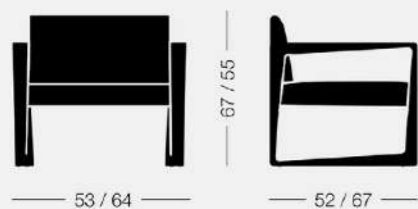

Askew 5C36 14,2 kg 0,37 m³ 1 pz

Lounge chair, struttura in legno
Lounge chair, wood frame

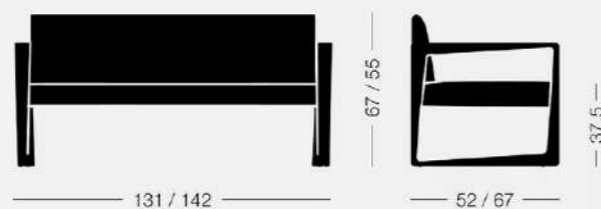

Askew 5C37 21,5 kg 0,72 m³ 1 pz

Divanetto, struttura in legno
Sofa, wood frame



Baby D.

design Billy Giuliani

Una seduta poliedrica di ispirazione nordica. La scocca dai contorni sinuosi si veste di pelle e tessuto e si adagia su una base in legno di faggio o acciaio verniciato. In un gioco di combinazioni infinite e colori audaci, Baby D. è la soluzione ideale per donare ad ogni ambiente una propria connotazione stilistica.

A many-side chair with a Nordic touch. The shell with sinuous outlines can be covered in leather or fabric and its placed on an beechwood or lacquered metal frame. In a play of infinite combinations and bold colours, Baby D. is the perfect product for giving a stylistic personalisation to any contract environment.







Baby D.

design Billy Giuliani

Collezione di sedute con base in faggio tinto o laccato, acciaio verniciato o base girevole, con rivestimento in tessuto, pelle o ecopelle.

Seat collection in stained or lacquered beechwood, lacquered steel frame or swivel base, with fabric, leather or eco-leather upholstery.

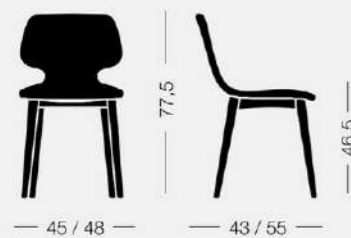

Baby D. 0C17 4,6 kg 0,32 m³ 2 pz

Sedia, base in legno
Chair, wood base

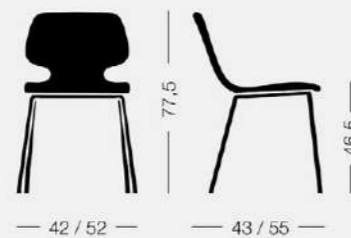

Baby D. 0C18 4,7 kg 0,34 m³ 2 pz

Sedia, struttura in acciaio
Chair, steel frame

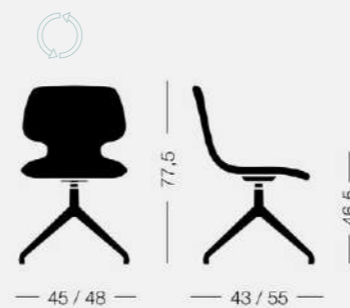

Baby D. 0C19 6,1 kg 0,32 m³ 2 pz

Sedia, base girevole
Chair, swivel base

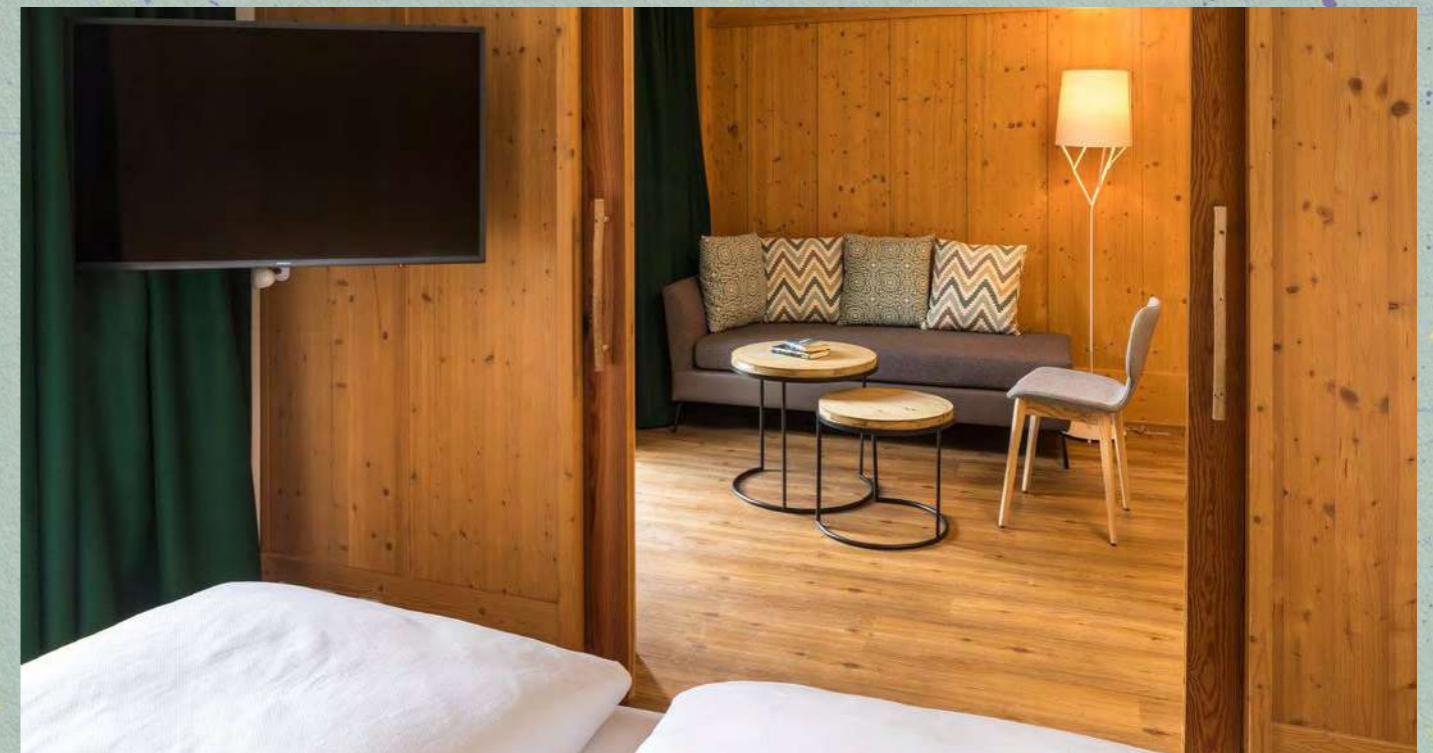

Billa

design Claudio Avetta

Billa coniuga in maniera armoniosa forme archetipe e familiari con un linguaggio formale fresco e contemporaneo. Lo schienale a tutta altezza abbraccia e avvolge il sedile, conferendo alla sedia unità e continuità organica, cui fa da contrappunto la struttura in legno massello di faggio: comoda la versione tutta legno, ancor di più se con sedile imbottito. Offerta in diversi colori che ne esaltano il carattere, Billa combina rigore e chiarezza costruttiva con una forma espressiva e dinamica in grado di esaltare le caratteristiche materiche del legno

Billa harmoniously combines well established shapes with fresh, contemporary formal language. The generous backrest wraps round to frame the seat, giving the chair unity and organic continuity, in line with its solid beechwood frame: the all-wood version is definitely comfortable and even more so with an upholstered seat. Billa comes in various colours that enhance its character, combining rigour and constructive clarity with a dynamically expressive shape that highlights the very essence of the wood itself..













copiosa

SEATING FOR CONTRACT

Billa

design Claudio Avetta

Sedia in faggio tinto o laccato, disponibile anche la versione con sedile imbottito.

Beechwood chair stained or lacquered, available with upholstered seat.



Billa 1C50 4,70 kg 0,34 m 2 pz

Sedia, sedile e schienale in legno.
Chair, wood seat and backrest.

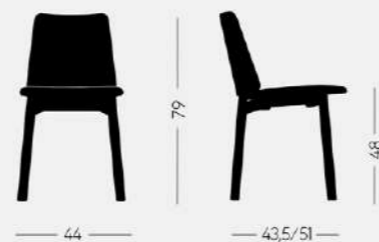

Billa 1C51 5,50 kg 0,34 m 2 pz

Sedia, sedile imbottito, schienale in legno.
Chair, upholstered seat, wood backrest.



Bold

design Studio Pastina

Aperto e flessibile per concezione, il sistema di sedute Bold nasce per rispondere alle nuove esigenze del vivere contemporaneo. Poltrone e divanetti, divisori in varie altezze, tavolini e accessori multifunzione: questi sono gli elementi con cui Bold ridisegna gli spazi attraverso infinite possibilità di configurazione. Le forme morbide seguono principi di modularità e accoglienza, garantendo comfort e privacy e al contempo condivisione degli spazi e convivialità.

Open and flexible, the Bold seating system is designed to satisfy all needs of contemporary living. Lounge chairs and sofas, dividers in various heights, side tables and multifunctional accessories: these are the elements through which Bold can create new spaces with infinite combinations. Soft shapes follow the principles of modularity and hospitality, and are able to offer comfort, privacy, sharing and conviviality.











copiosa

SEATING FOR CONTRACT

Bold

design Studio Pastina

Sistema di sedute con base in acciaio verniciato e rivestimento in tessuto. Tavolino con base in acciaio e piano in mdf.

Seating system with a lacquered steel frame and fabric upholstery. Table with a lacquered steel frame and mdf top.

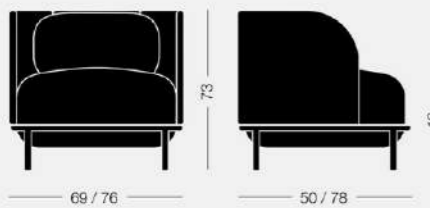

Bold 0C90 28,5 kg 0,50 m³ 1 pz

Lounge chair, schienale basso
Lounge chair, low backrest

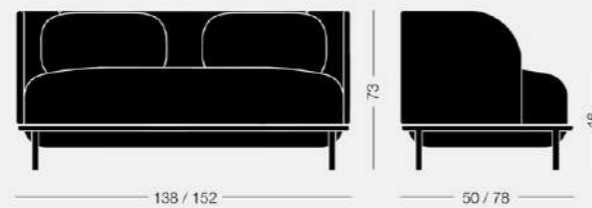

Bold 0C95 58 kg 0,96 m³ 1 pz

Divano due posti, schienale basso
Two seater sofa, low backrest

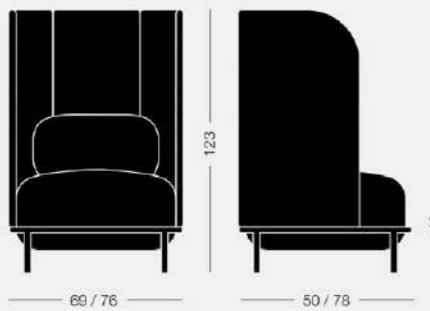

Bold 0C92 39,2 kg 0,82 m³ 1 pz

Lounge chair, schienale alto
Lounge chair, high backrest

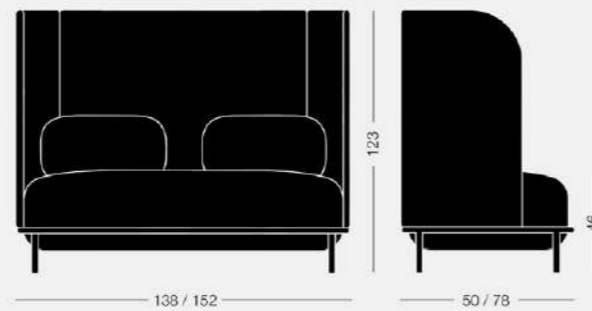

Bold 0C96 70 kg 1,70 m³ 1 pz

Divano due posti, schienale alto
Two seater sofa, high backrest



Bold 0C93 17,7 kg 0,31 m³ 1 pz

Pouf
Pouf



Bold 0C98 10,5 kg 0,15 m³ 1 pz

Tavolinetto
Side table



Bold 0C94 48 kg 0,60 m³ 1 pz

Ottoman
Ottoman



B. Outdoor

design Copiosa Lab

Toni glamour e dettagli di stile per uno spazio outdoor che esprime uno stile di vita fuori dagli schemi. La collezione è composta da divanetto due posti, lounge e tavolino. Struttura in metallo laccato, intreccio in cima nautica, spalliera in legno di frassino.

Glamorous tones and stylish details for an outdoor space that expresses an unconventional lifestyle. The collection consisting of a two-seater sofa, a lounge and a coffee table. Lacquered metal structure, nautical rope weave, ash wood back.

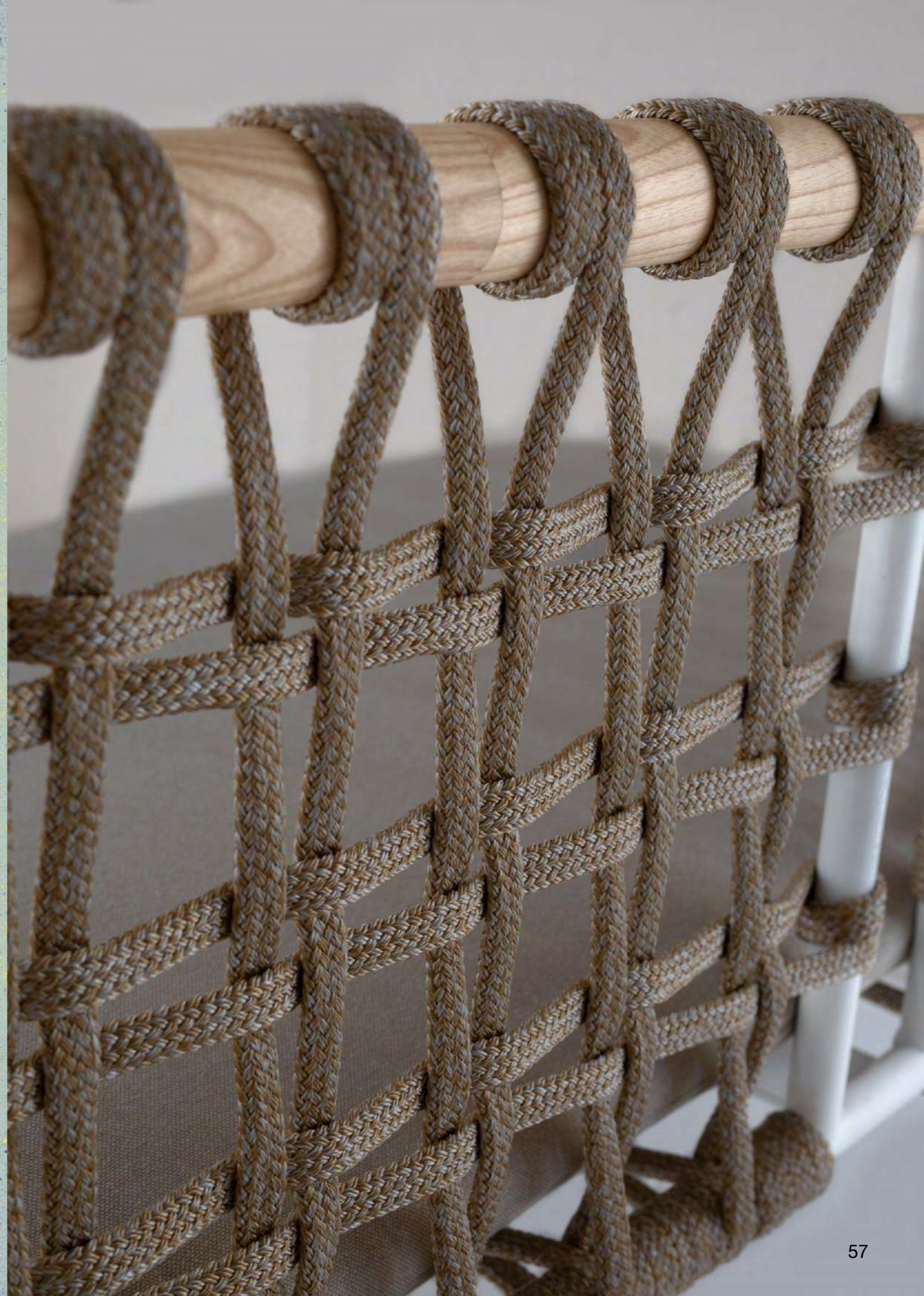







copiosa

SEATING FOR CONTRACT

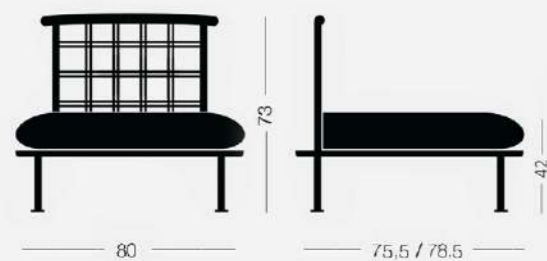

B Outdoor 0C97 12,4 kg 0,50 m3 1 pz

Lounge
Lounge chair

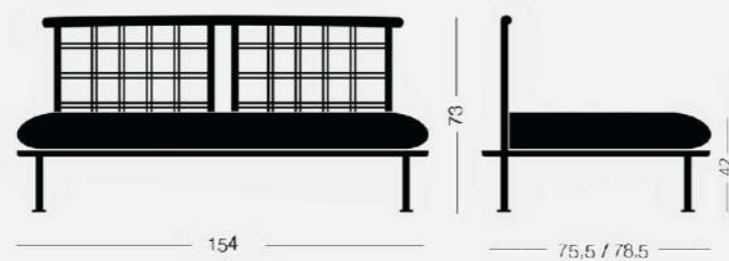

B Outdoor 0C99 22,5 kg 0,85 m3 1 pz

Divano due posti
Two seater sofa



B Outdoor

design Studio Pastina

Lounge e divano due posti con struttura in metallo laccato. intreccio in cima nautica e spalliera in legno. Tavolino con base in acciaio e piano in mdf.

Lounge chair and two-seater sofa with lacquered metal structure, nautical rope weave and wooden back. Table with a lacquered steel frame and mdf top.



B Outdoor 0C89 11,5kg 0,15m3 1 pz

Tavolinetto
Side table



Button Down

design Tom Kelly

Sedie, poltroncine e sgabelli, contraddistinti da una struttura delicatissima, diventano simbolo di leggerezza e carattere. Il dettaglio dell'innesto a bottone tra telaio e schienale è il tratto distintivo di una collezione iconica e trasversale. Disponibile in tondino di acciaio, con sedile e schienale imbottiti o in essenza di faggio e frassino, Button Down è un modello di grande versatilità.

Chairs, armchairs and barstools stand out for their strikingly delicate frame and are a symbol of lightness and personality. Distinguished by the way the back is buttoned into the frame, Button Down is an across-the-board iconic collection. Available in steel rod frame with seat and back either upholstered, or in beech or ashwood, it's a model of great versatility.





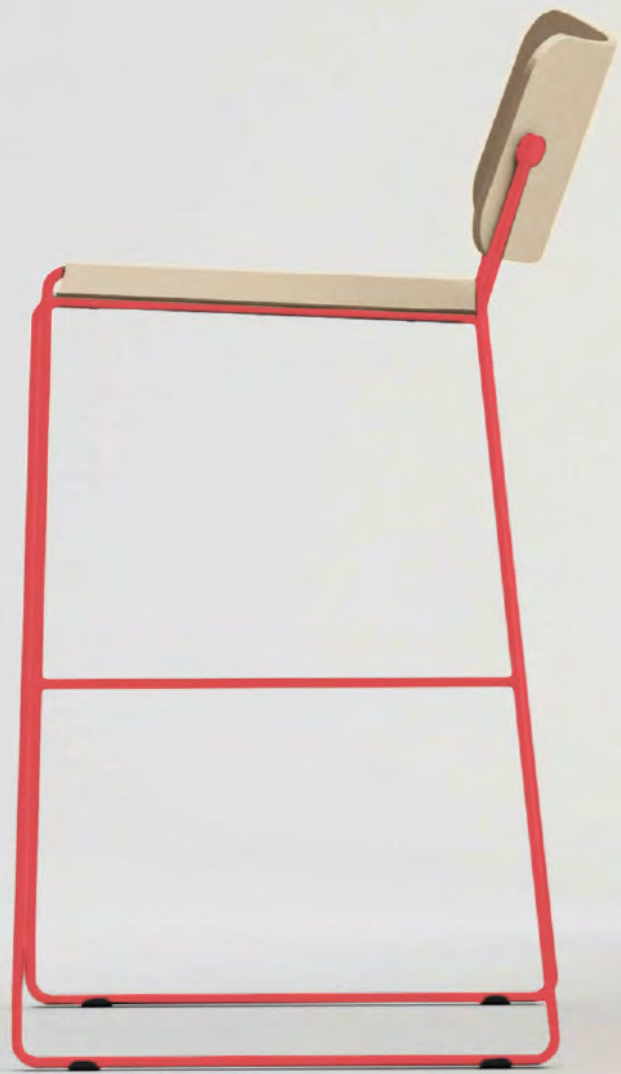



copiosa

SEATING FOR CONTRACT

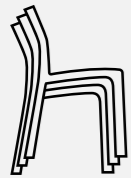

stackable
impilabile

Button Down

design Tom Kelley

Sedie impilabili, poltroncine e sgabelli con struttura in tondino di acciaio verniciato. Schienale e sedile in essenza di faggio e frassino oppure imbottiti.

Stackable chairs, armchairs and barstools with lacquered steel rod frame. Seat and back either upholstered, or in beech or ashwood.

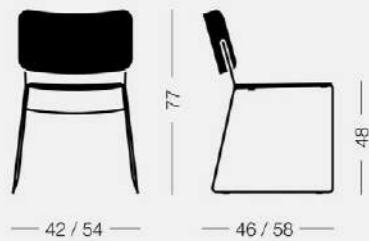

Button Down 7C20 7,3 kg 0,38 m³ 2 pz

Sedia, sedile e schienale in legno
Chair, wood seat and backrest

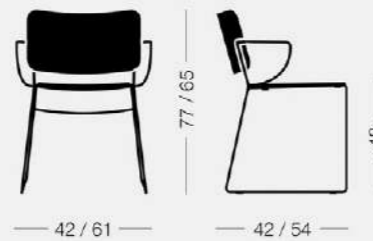

Button Down 7C22 8,1 kg 0,38 m³ 2 pz

Poltroncina, sedile e schienale in legno
Armchair, wood seat and backrest

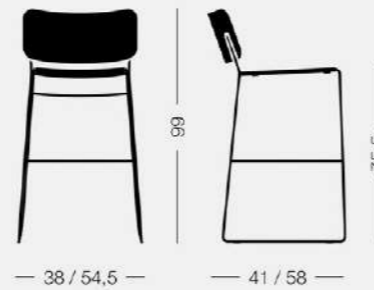

Button Down 7C25 9,5 kg 0,32 m³ 1 pz

Sgabello, sedile e schienale in legno
Barstool, wood seat and backrest

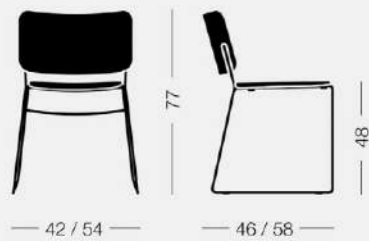

Button Down 7C21 7,3 kg 0,38 m³ 2 pz

Sedia, sedile e schienale imbottiti
Chair, upholstered seat and backrest

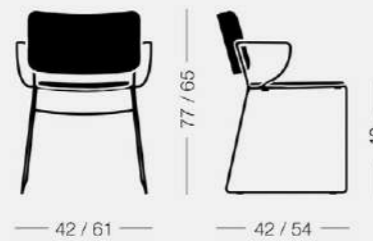

Button Down 7C23 8,1 kg 0,38 m³ 2 pz

Poltroncina, sedile e schienale imbottiti
Armchair, upholstered seat and backrest

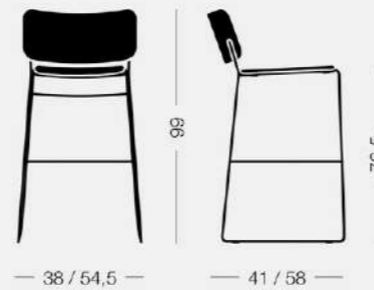

Button Down 7C24 9,5 kg 0,32 m³ 1 pz

Sgabello, sedile e schienale imbottiti
Barstool, upholstered seat and backrest



Centouno

design AtelierNanni

Leggera, versatile, impilabile, colorata... sedia e poltroncina arricchite dal cuscino opzionale.

Light, versatile, stackable, colorful ... chair and small armchair enriched by the optional cushion.









copiosa

SEATING FOR CONTRACT

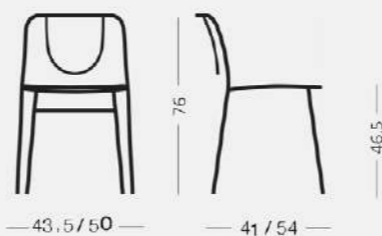

Centouno 1C10 4,10 kg 0,27 m 2 pz

Sedia, struttura in ferro
Chair, steel structure

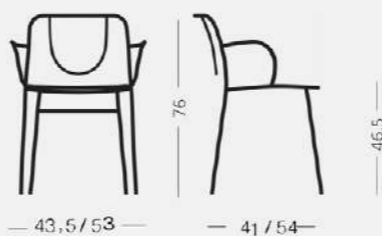

Centouno 1C14 4,70 kg 0,24 m 1 pz

Poltroncina, struttura in ferro
Armchair, steel structure

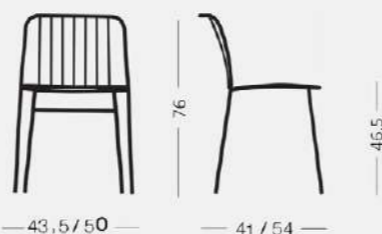

Centouno 1C11 4,10 kg 0,27 m 2 pz

Sedia, struttura in ferro
Chair, steel structure

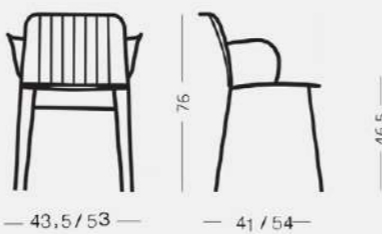

Centouno 1C16 4,70 kg 0,24 m 1 pz

Poltroncina, struttura in ferro
Armchair, steel structure

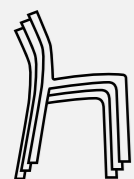

stackable
impilabile



outdoor

Centouno

design AtelierNanni

Sedia e poltroncina impilabile con struttura in tondino di ferro verniciato, cuscino opzionale.

Stackable chair and armchair with lacquered steel rod frame, optional cushion.



Eileen

design Werther Toffoloni

Classica per eccellenza, Eileen è una collezione senza tempo di marcata eleganza. Sedia, poltroncina, poltrona e sgabello: queste confortevoli sedute sono arricchite da dettagli costruttivi che esaltano le pregiate lavorazioni del legno. La pelle dei cuscini e le essenze di faggio della struttura si uniscono in un connubio ideale di classe e comfort.

Classic excellence. A timeless collection with distinctive elegance. Comfortable chairs, armchairs, lounge chairs and barstools are enriched by construction features that highlight the masterful woodwork. Leather cushions and a stained beech or american walnut structure are an ideal union of class and comfort.







Eileen

design Werther Toffoloni

Collezione di sedute in essenza di faggio tinto o laccato, rivestite in tessuto, pelle o ecopelle.

Seat collection in stained or lacquered beechwood, with fabric, leather or eco-leather upholstery.

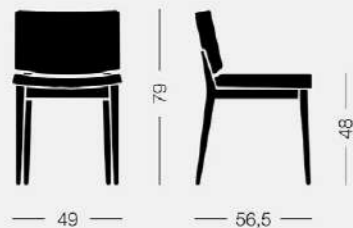

Eileen 7C01 9,5 kg 0,37 m³ 2 pz

Sedia, struttura in legno
Chair, wood frame



Eileen 7C02 10 kg 0,30 m³ 1 pz

Poltroncina, struttura in legno
Armchair, wood frame

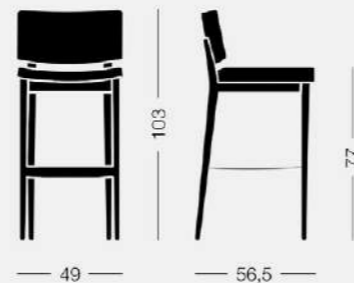

Eileen 7C03 11,2 kg 0,33 m³ 1 pz

Sgabello, struttura in legno
Barstool, wood frame

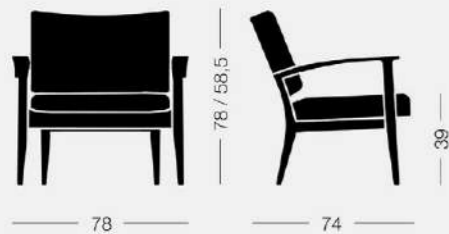

Eileen 7C05 15,5 kg 0,48 m³ 1 pz

Lounge chair, struttura in legno
Lounge chair, wood frame



Labs TLV, , Tel Aviv, Israele



Wellington Building, , Irlanda 93

Float

design Studio Pastina

La collezione Float offre soluzioni versatili per organizzare e rimodulare gli ambienti contemporanei. I pannelli imbottiti e rivestiti in tessuto, uniti a sostegni dalle linee pulite, donano personalità e colore allo spazio, adattandosi a ogni tipo di contesto sia domestico che lavorativo. Float permette la creazione di diverse composizioni, può essere personalizzata in un'ampia gamma di finiture e corredata da accessori che ne arricchiscono le funzionalità.

The Float collection offers adaptable solutions in organizing and redesigning contemporary spaces. These upholstered screen panels, together with cleanly designed pedestals, add personality and colour to the environment and are suitable for both domestic and work contexts. The Float collection gives the opportunity to create multiple compositions. It can be customized in a wide range of finishings and equipped with optional accessories in order to broaden its range of applications.







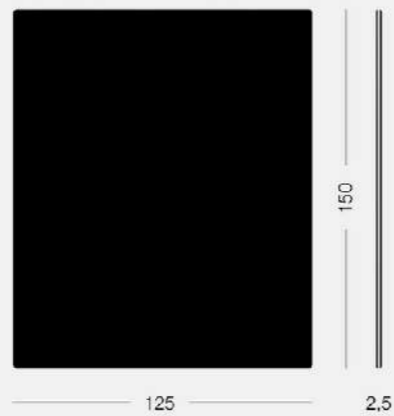

Float 0C00 8,50 kg 0,08 m³ 1 pz
Pannello, multistrato imbottito
Panel, upholstered wood

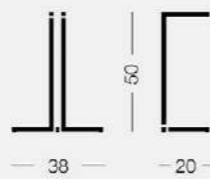

Float 0C00 2,25 kg 0,05 m³ 2 pz
Basamento, acciaio
Pedestal, steel



Float

design Studio Pastina

Pannello divisorio in multistrato di betulla rivestito in tessuto. Base in tubolare di acciaio tagliato laser e verniciato a polvere.

Room divider in upholstered birchwood. Pedestal in laser cut, powder coated steel.

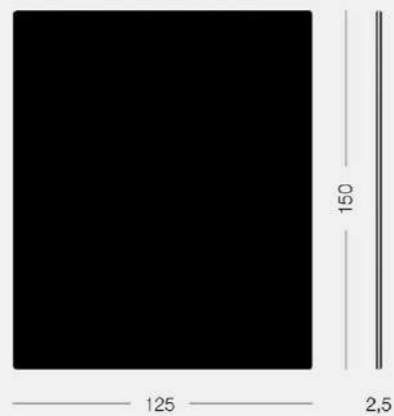

Float 0C01 8,50 kg 0,08 m³ 1 pz
Pannello, multistrato imbottito
Panel, upholstered wood

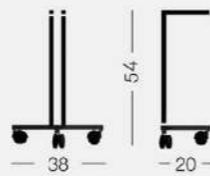

Float 0C01 2,25 kg 0,05 m³ 2 pz
Basamento, acciaio
Pedestal, steel



Galileo

design Studio Pastina

Con un disegno che rievoca suggestioni astronomiche, Galileo rielabora il tema del tavolo bistrot con base centrale. Le gambe sottili convergono in un unico elemento che sorregge con eleganza geometrica il piano d'appoggio. Disponibile nelle varianti con piano circolare o quadrato e in quattro altezze, Galileo si propone come soluzione di grande versatilità, grazie anche alle numerose varianti colore.

With a hint of astronomy in its design, Galileo revisits the idea of a bistro table with central column. Its slender legs converge stylishly and geometrically to support its table top. Available at four heights and with square or rounds tops, Galileo can slot into all kinds of settings thanks also to its wide choice of colourways.









Galileo

design Studio Pastina

Collezione di tavoli con struttura in acciaio verniciato, con piani in mdf o hpl tinto o laccato.

Table collection with lacquered steel base and stained or lacquered mdf or hpl top.

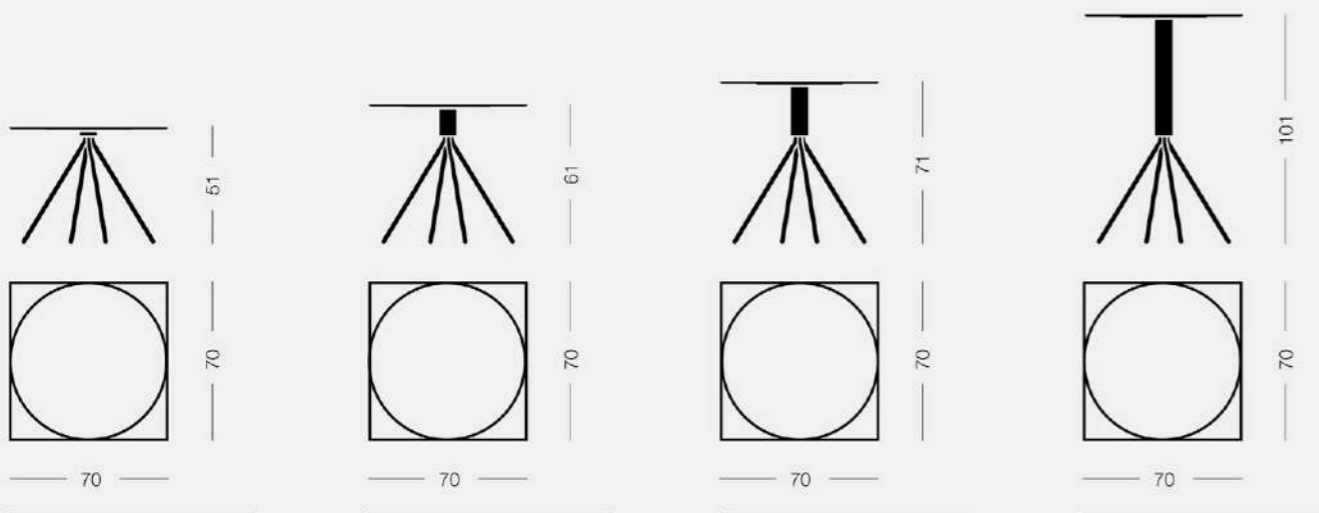

Galileo 0C01
3 kg 0,16 m³ 1 pz

Galileo 0C02
3,7 kg 0,17 m³ 1 pz

Galileo 0C03
4,4 kg 0,21 m³ 1 pz

Galileo 0C04
6,5 kg 0,40 m³ 1 pz



losa

design Copiosa Lab

Un piano adagiato su elementi tubolari che si diramano per creare una base stabile e leggera. Il tavolo losa è esempio di semplicità ed efficacia ed è disponibile in due altezze e con piano circolare o quadrato. Essenziale e discreto, risponde senza esitazioni ad ogni esigenza.

Tubular splayed steel legs with a round or square table top gently resting on it. This simple and functional combination allows the losa table discreetly and effectively to fulfill any needs. Available at a choice of heights.







copiosa

SEATING FOR CONTRACT



losa

design Copiosa Lab

Collezione di tavoli con struttura in acciaio verniciato, con piani in mdf o hpl tinto o laccato.

Table collection with lacquered steel base and stained or lacquered mdf or hpl top.

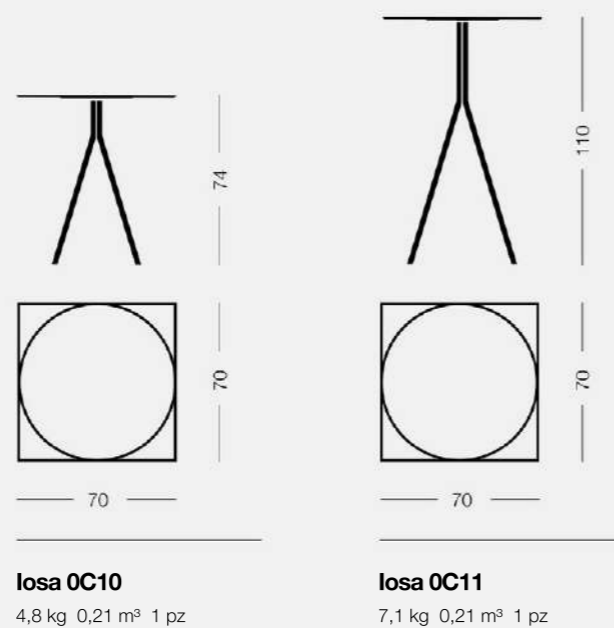

Kursaal

design Emilio Nanni

Grande comfort e resistenza per rispondere con efficacia alle esigenze degli spazi collettivi. Elegante e versatile: offre la possibilità di uno schienale dall'ampio sostegno oppure più basso e snello. Struttura in massello di faggio, sedile e schienale imbottiti con rivestimento in tessuto.

Exceptional comfort and durability make Kursaal ideal in heavy-duty commercial settings. Stylishly versatile with a choice of a back rest: higher or lower. In solid Beechwood with seat and back upholstered in fabric.







Kursaal

design Emilio Nanni

Collezione di sedute in faggio tinto o laccato, rivestite in tessuto.

Seat collection in stained or lacquered beechwood, with fabric.



Kursaal 7C10 9,6 kg 0,30 m³ 1pz

Poltroncina, struttura in legno
Armchair, wood frame

Kursaal 7C12 11,9 kg 0,36 m³ 1pz

Lounge, struttura in legno
Lounge chair, wood frame



Link

design Studio Pastina

Link è una seduta iconica dalle linee sinuose e accoglienti. Materiali diversi, come l'elegante frassino a poro aperto, il tessuto e l'acciaio, si legano in un'armonia di contrasti, dando vita ad una seduta originale e contemporanea. Disponibile con sedile e schienale in frassino, solo sedile imbottito o entrambi imbottiti, Link è esempio di versatilità. Grazie alle molteplici possibilità di combinare materiali e finiture è un prodotto dalla spiccata personalità, capace di valorizzare ogni ambiente.

The sinewy lines and curves of the Link chair make it quite iconic. Various materials such as fine, open-pore ashwood, quality fabrics and metal, all bind together harmoniously to bring life to this original and contemporary design. Link is available: with seat and back in ashwood; with seat upholstered; or with both seat and back upholstered. These multiple combinations of fabrics and finishes give Link a feisty personality and allow it to enhance any setting whatsoever.







copiosa

SEATING FOR CONTRACT

Link

design Studio Pastina

Seduta con gambe posteriori in frassino tinto o laccato e gambe anteriori in acciaio verniciato. Schienale e sedile in essenza di frassino oppure imbottiti.

Chair with stained or lacquered ashwood back legs and lacquered steel front legs. Seat and back either in ashwood or upholstered.

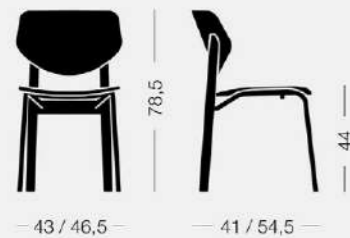

Link OC70 5,2 kg 0,38 m³ 2 pz

Sedia, sedile e schienale in legno
Chair, wood seat and backrest

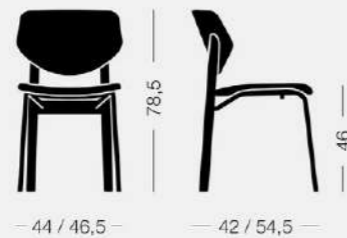

Link OC71 5,8 kg 0,38 m³ 2 pz

Sedia, sedile imbottito, schienale in legno
Chair, upholstered seat, wood backrest

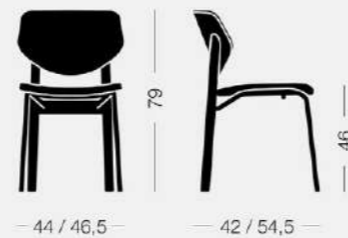

Link OC72 6,4 kg 0,38 m³ 2 pz

Sedia, sedile imbottito, schienale in legno con cuscino
Chair, upholstered seat, wood backrest with cushion



Marilyn

design Graziella e Renzo Faciglietti

Le linee morbide e dolci della collezione Marilyn infondono immediata accoglienza e ricordano iconiche figure. Le varianti poltroncina, lounge e sgabello sono disponibili con struttura in massello di faggio o in metallo e scocca con rivestimento in tessuto, pelle o ecopelle. Grazie alle proporzioni generose e avvolgenti, Marilyn è un invito alla comodità.

The sweet and gentle lines of the Marilyn collection are instantly inviting and they recall iconic figures. Armchair, lounge chair and barstool are available with a solid beech or metal frame with shell upholstered in fabric, leather or faux leather. With its generous and enveloping proportions, Marilyn is an invitation to comfort.









copiosa

SEATING FOR CONTRACT



Marilyn Wood 7C31 5,4 kg 0,30 m³ 1 pz

Poltroncina, base in legno
Armchair, wood base

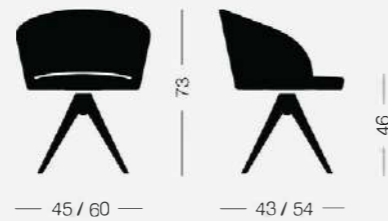

Marilyn Wood 7C32 7,5 kg 0,30 m³ 1 pz

Poltroncina, base girevole in legno
Armchair, swivel wood base



Marilyn Wood 7C36 8 kg 0,34 m³ 1 pz

Sgabello, base in legno
Barstool, wood base

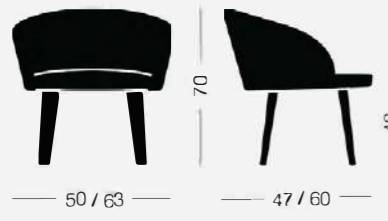

Marilyn Wood 7C34 7,4 kg 0,42 m³ 1 pz

Lounge chair, base in legno
Lounge chair, wood base

Marilyn Wood

design Graziella e Renzo Faciglietti

Collezione di sedute con base in massello di faggio tinto o laccato, con rivestimento in tessuto, pelle o ecopelle.

Seat collection in stained or lacquered beechwood, with fabric, leather or eco-leather upholstery.

Marilyn Steel

design Graziella e Renzo Faciglietti

Collezione di sedute con struttura in acciaio verniciato, con rivestimento in tessuto, pelle o ecopelle.

Seat collection with steel frame, with fabric, leather or eco-leather upholstery.

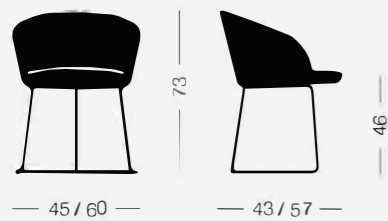

Marilyn Steel 7C40 7 kg 0,30 m³ 1 pz

Poltroncina, struttura in acciaio
Armchair, steel frame



Marilyn Steel 7C41 8 kg 0,30 m³ 1 pz

Poltroncina, base girevole
Armchair, swivel base



Marilyn Steel 7C58 6,5 kg 0,30 m³ 1 pz

Poltroncina, struttura in acciaio
Armchair, steel frame



Miami

design Tom kelley

Attraverso poche e semplici linee, Miami sintetizza uno stile di ispirazione art deco. Nelle varianti sedia e sgabello, le proporzioni ampie e lineari suggeriscono solidità e comfort. Disponibile con struttura in legno di faggio con sedile e schienale imbottiti e rivestiti in stoffa o pelle, Miami dona calore ed eleganza ad ambienti ricercati.

Thanks to few, simple lines, Miami summarizes an art deco inspired style. Chairs and barstools with wide and linear proportions suggest a feeling of solidity and comfort. Available with beechwood structure with seat and back upholstered in fabric or leather, Miami adds warmth and elegance to refined environments.







copiosa

SEATING FOR CONTRACT

Miami

design Tom Kelley

Sedia e sgabello in faggio tinto o laccato, con seduta e schienale rivestiti di tessuto, pelle o ecopelle.

Chair and barstool in stained or lacquered beechwood, with fabric, leather or eco-leather upholstery.

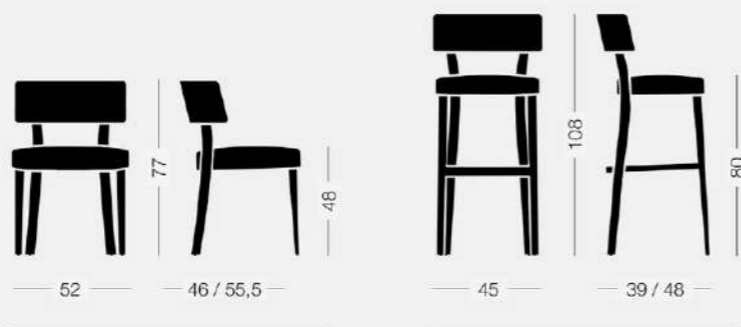

Miami 4C00 6,4 kg 0,36 m³ 2 pz

Sedia, base in legno
Chair, wood base

Miami 4C01 6,7 kg 0,28 m³ 1 pz

Sgabello, base in legno
Barstool, wood base



My Chair

design Emilio Nanni

Come non notare quelle caratteristiche “orecchie” che spuntano? My Chair ammicca con risolutezza irriverente mentre le gambe tornite, dalla base arrotondata, trasmettono una sensazione di morbidezza e delicatezza. La versione originale è completamente in legno di faggio, amplia il suo comfort nelle varianti con sedile imbottito.

You can't help but notice those characteristic sprouting “ears”! My Chair winks with bold irreverence while the turned legs from the rounded base transmit a feeling of softness and delicateness. The original version is completely in beech wood, adding comfort in the variant with upholstered seat.









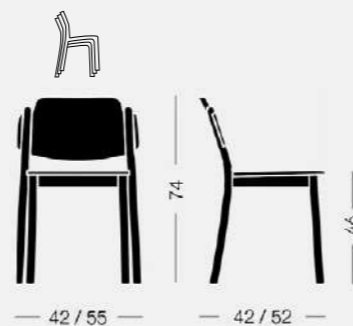

My Chair 1C40 5 kg 0,34 m³ 2 pz

Sedia, sedile e schienale in legno
Chair, wood seat and backrest

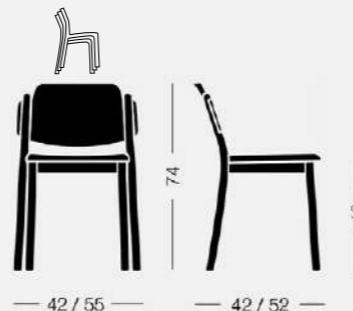

My Chair 1C41 5 kg 0,34 m³ 2 pz

Sedia, sedile imbottito, schienale in legno
Chair, upholstered seat, wood backrest

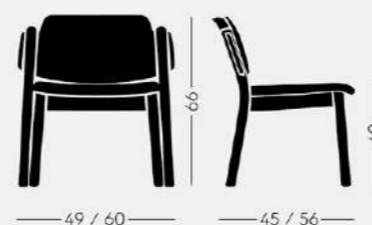

My Chair 1C42 6,5 kg 0,41 m³ 2 pz

Lounge, sedile imbottito, schienale imbottito.
Lounge Chair, upholstered seat, upholstered backrest

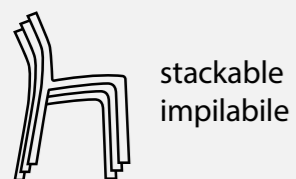

My Chair

design Emilio Nanni

Sedia e lounge in faggio tinto o laccato, disponibile anche la versione con sedile imbottito.

Beechwood chair and lounge chair stained or lacquered, available with upholstered seat.



Rose

design Billy Giuliani

Due petali di multistrato rivestiti in tessuto, pelle o ecopelle si sposano con le basi in faggio tinto o laccato e metallo. Rose è una seduta caratterizzata da linee sinuose che, nella versione poltroncina, si estendono in due ali avvolgenti e creano un appoggio confortevole per le braccia.

Two plywood petals covered in fabric, faux or genuine leather, combined with stained or lacquered beechwood and metal. Rose is a chair characterized by sinuous lines which expand, in the armchair version, into two enveloping wings that also serve as comfortable armrests.







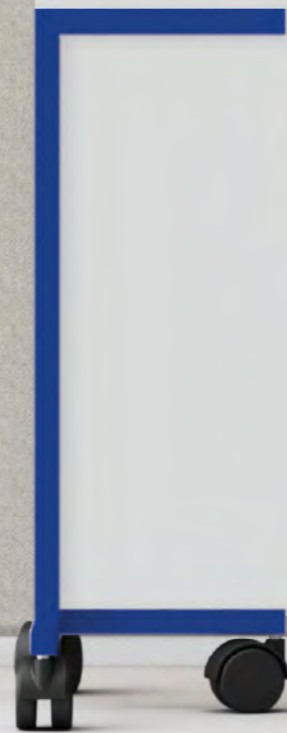



copiosa

SEATING FOR CONTRACT

Rose Wood

design Billy Giuliani

Sedia e poltroncina in faggio tinto o laccato, con rivestimento in tessuto, pelle o ecopelle.

Chair and armchair in stained or lacquered beechwood, with fabric, leather or eco-leather upholstery.

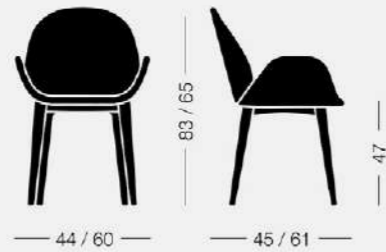
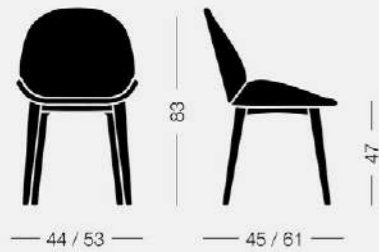

Rose 0C30 7,0 kg 0,30 m³ 1 pz

Sedia, base in legno
Chair, wood base

Rose 0C31 8,1 kg 0,33 m³ 1 pz

Poltroncina, base in legno
Armchair, wood base

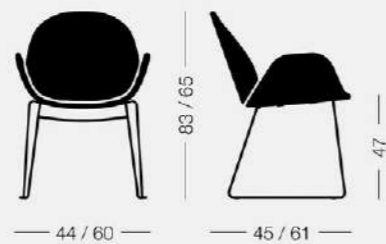
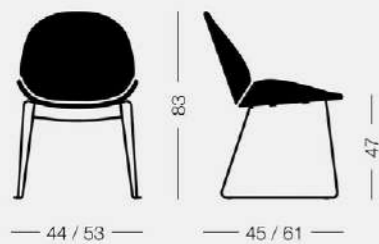

Rose 0C34 9,2 kg 0,30 m³ 1 pz

Sedia, struttura in acciaio
Chair, steel frame

Rose 0C35 10,3 kg 0,33 m³ 1 pz

Poltroncina, struttura in acciaio
Armchair, steel frame

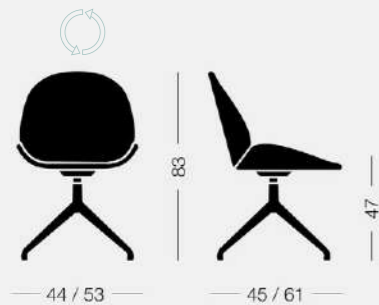

Rose 0C36 9,0 kg 0,30 m³ 1 pz

Sedia, base girevole
Chair, swivel base

Rose 0C37 10,1 kg 0,33 m³ 1 pz

Poltroncina, base girevole
Armchair, swivel base

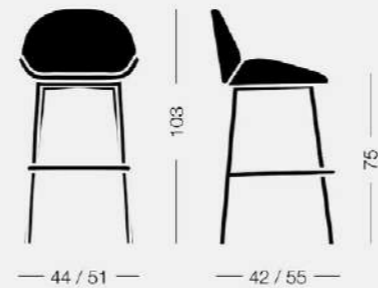

Rose 0C39 8,7 kg 0,31 m³ 1 pz

Sgabello, struttura in acciaio
Barstool, steel frame

Rose Steel

design Billy Giuliani

Sedia, poltroncina e sgabello con struttura in acciaio verniciato o base girevole, con rivestimento in tessuto, pelle o ecopelle.

Chair, armchair and barstool with a lacquered steel frame or swivel base, with fabric, leather or eco-leather upholstery.



Serpentine

design Miquadra

Una poltroncina essenziale ed elegante. Abbina un sottile accenno agli anni '50 a proporzioni e finiture contemporanee per un perfetto connubio che valorizza sia ambienti conviviali che professionali. La linea distintiva della struttura in acciaio sostiene e abbraccia l'utilizzatore, donandole ulteriore carattere e comfort. Nella versione outdoor l'elegante poltroncina in metallo viene impreziosita da un insolito intreccio in cima nautica.

An elegantly compact armchair that combines a subtle fifties touch with contemporary proportions and finishes in perfect harmony to enhance both professional and social environments. The distinctive lines of the steel frame support and embrace the user, assuring added character and comfort. In the outdoor version, the elegant metal armchair is embellished with an unusual nautical rope weave.









copiosa

SEATING FOR CONTRACT

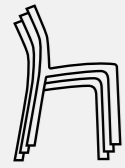

stackable
impilabile

Serpentine

design Miquadra Design

Poltroncina impilabile con struttura in tondino di acciaio verniciato, sedile e schienale imbottiti.

Stackable armchair with lacquered steel rod frame, upholstered seat and back.

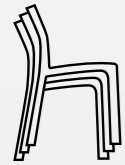

stackable
impilabile



outdoor

Serpentine Outdoor

design Miquadra Design

Poltroncina impilabile con struttura in tondino di acciaio verniciato, sedile e schienale intrecciati.

Stackable armchair with lacquered steel rod frame, woven seat and back.

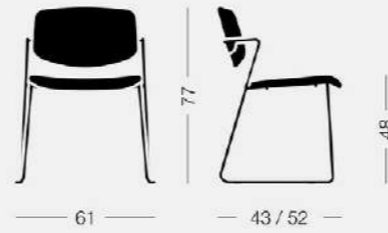

Serpentine 1C00 6,8 kg 0,36 m³ 2 pz

Poltroncina, struttura in acciaio
Armchair, steel structure

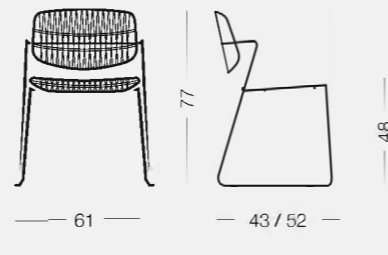

Serpentine Outdoor 1C01 6,00 kg 2 pz

Poltroncina, struttura in acciaio
Armchair, steel structure

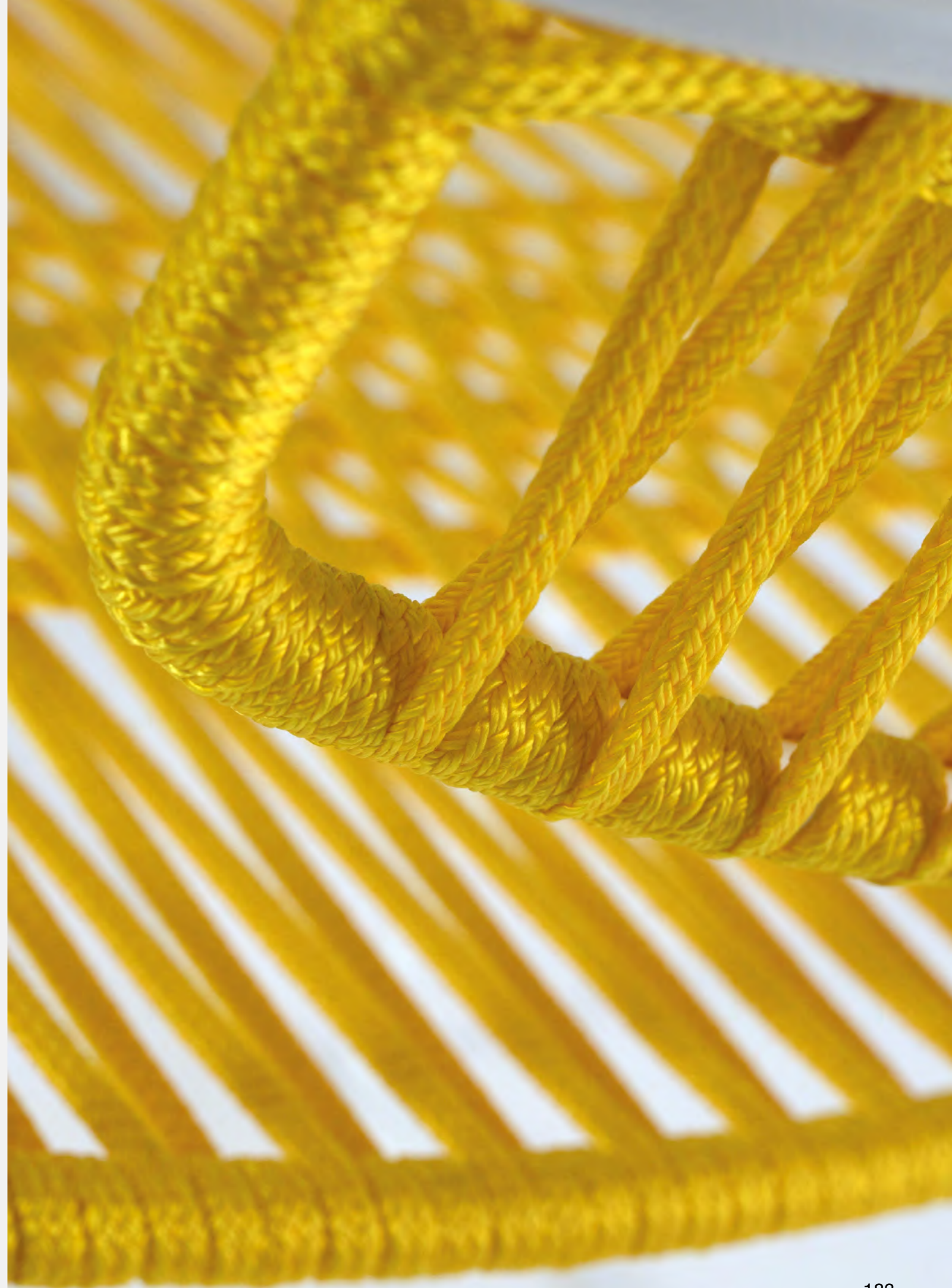

Spoon

design Studio Pastina

L'abbraccio fra uno schienale avvolgente e un morbido sedile si ispira ad antichi simboli di prosperità. Rotondità e abbondanza sono protagoniste in questa ricca collezione di sedute dalle linee accoglienti. Nelle varianti sedia, sgabello e lounge chair, rivestita in tessuto con base in legno di faggio, Spoon è una seduta di estremo comfort dalla personalità allegra e contemporanea.

The embrace between a backrest and a soft seat is inspired by ancient symbols of prosperity. Roundness and abundance are protagonists of this rich and welcoming collection. Available as chair, barstool and lounge chair, covered in fabric with an beechwood base, Spoon is a product of exceptional comfort with a cheerful and contemporary personality.









copiosa

SEATING FOR CONTRACT

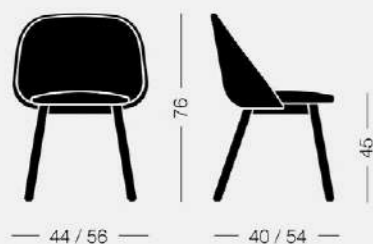

Spoon 0C80 7,0 kg 0,31 m³ 2 pz

Sedia, base in legno
Chair, wood base



Spoon 0C81 7,3 kg 0,30 m³ 1 pz

Sgabello, base in legno
Barstool, wood base

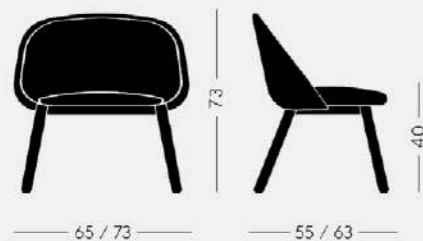

Spoon 0C82 8,0 kg 0,42 m³ 1 pz

Lounge chair, base in legno
Lounge chair, wood base

Spoon Wood

design Studio Pastina

Collezione di sedute con base in faggio tinto o laccato e schienale in poliuretano espanso rivestito in tessuto, pelle o ecopelle.

Seat collection in stained or lacquered beechwood, with polyurethane foam backrest upholstered in fabric, leather or eco-leather.

Spoon Steel

design Studio Pastina

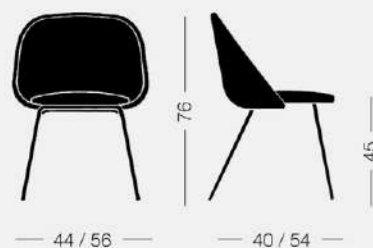

Spoon 0C83 7,5 kg 0,31 m³ 2 pz

Sedia, struttura in acciaio
Chair, steel base



Spoon 0C84 7,5 kg 0,31 m³ 2 pz

Sedia, base girevole
Chair, swivel base

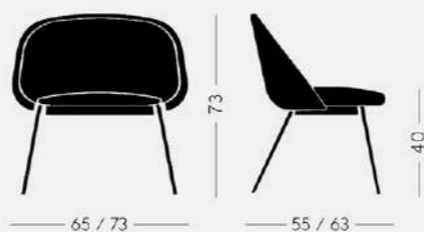

Spoon 0C86 8,5 kg 0,42 m³ 1 pz

Lounge chair, struttura in acciaio
Lounge chair, steel base



Wrap

design Copiosa Lab

Le sedute metal-chic che sanno coniugare la ricercatezza con la semplicità. Confortevole e funzionale, Wrap Family lancia segnali di uno stile trasversale. Due versioni di schienale, ampio o essenziale, la traghettano verso richieste diversificate che ottengono facili consensi sia in contesti di tendenza quanto in quelli più eleganti e formali.

The metal-chic collection that manages to combine elegance with simplicity. Comfortable and functional, Wrap emits signs of a transversal style. Two versions of backrest, wide or compact, make Wrap fulfil all types of requests as it slots easily into both trendy and more elegant and formal settings.





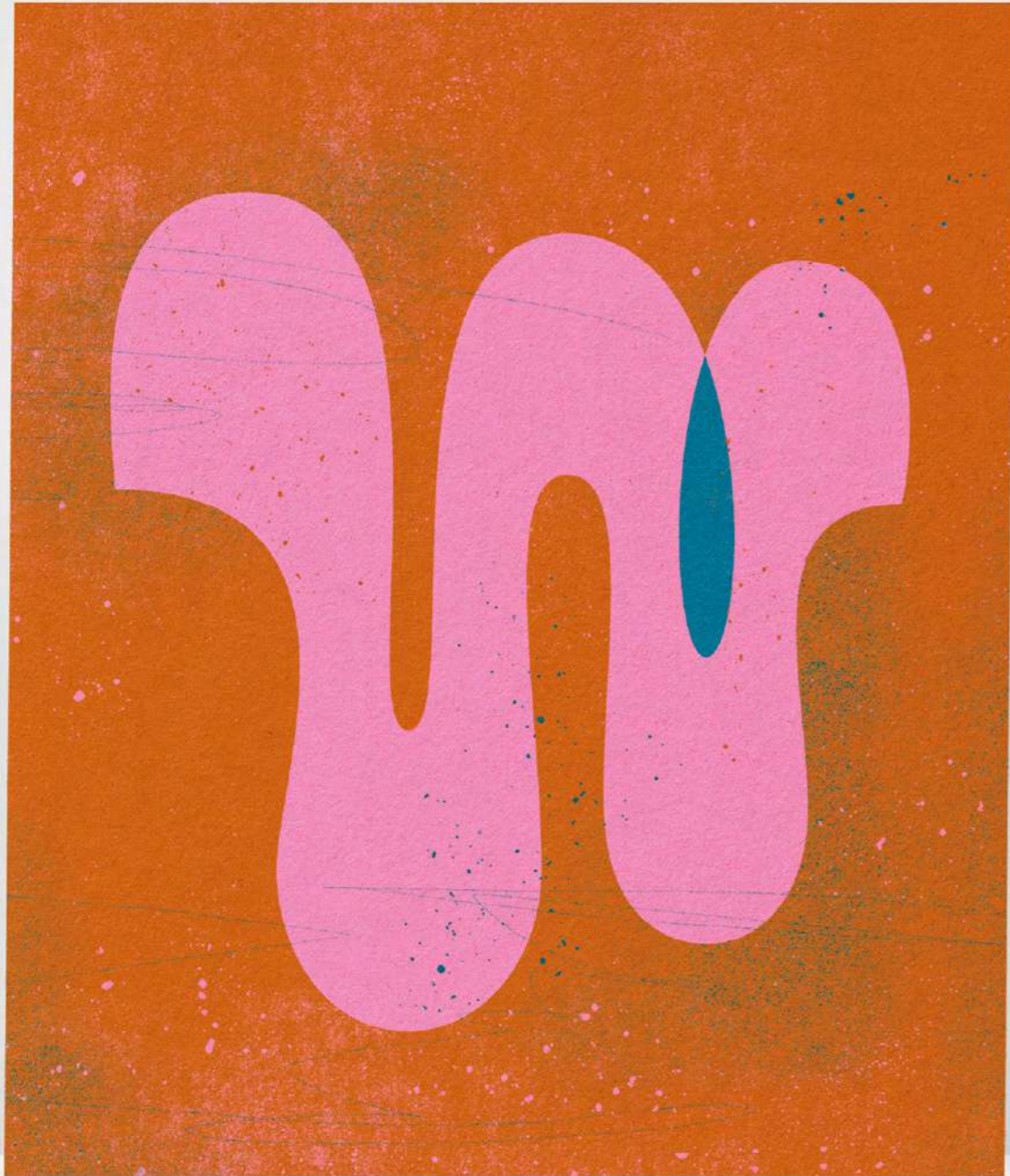





copiosa

SEATING FOR CONTRACT

Wrap Wood

design Copiosa Lab

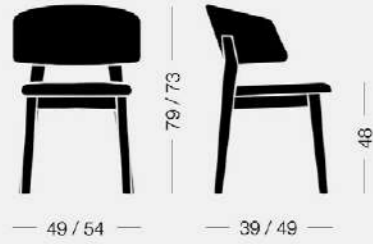

Wrap 6C60 7,2 kg 0,23 m³ 1 pz
Poltroncina, base legno
Armchair, wood base

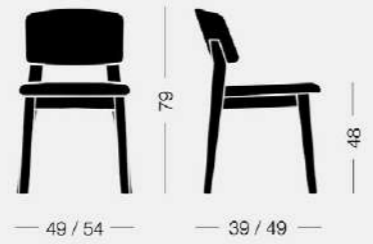

Wrap 6C62 7,0 kg 0,34 m³ 2 pz
Sedia, base legno
Chair, wood base



Wrap 6C64 8,2 kg 0,32 m³ 1 pz
Sgabello, base legno
Barstool, wood base

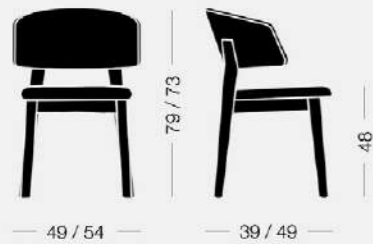

Wrap Wood 6C61 7,2 kg 0,23 m³ 1 pz
Poltroncina, base legno, schienale legno a vista
Armchair, wood base, show-wood backrest

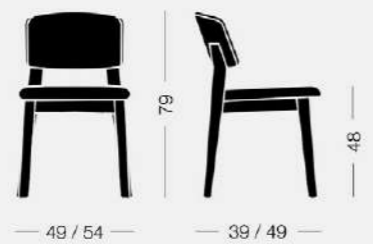

Wrap Wood 6C63 7,0 kg 0,35 m³ 2 pz
Sedia, base legno, schienale legno a vista
Chair, wood base, show-wood backrest



Wrap Wood 6C65 8,2 kg 0,32 m³ 1 pz
Sgabello, base legno, schienale legno a vista
Barstool, wood base, show-wood backrest

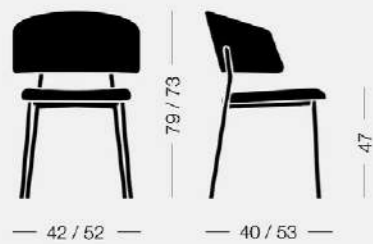

Wrap Steel 6C70 5,4 kg 0,24 m³ 1 pz
Poltroncina, struttura in acciaio
Armchair, steel frame

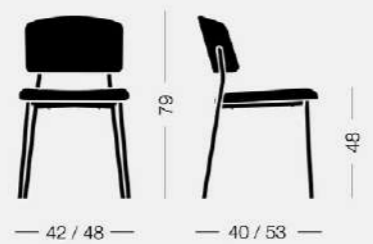

Wrap Steel 6C71 4,6 kg 0,38 m³ 2 pz
Sedia, struttura in acciaio
Chair, steel frame

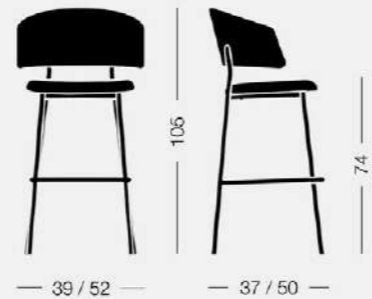

Wrap Steel 6C72 6,5 kg 0,30 m³ 1 pz
Sgabello, struttura in acciaio
Barstool, steel frame

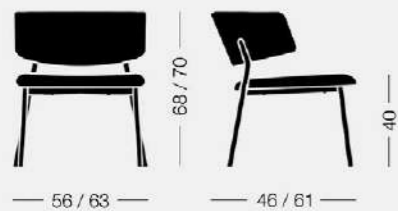

Wrap Steel 6C74 7,0 kg 0,29 m³ 1 pz
Lounge chair, struttura in acciaio
Lounge chair, steel frame

Wrap Steel

design Copiosa Lab

Collezione di sedute con struttura in acciaio verniciato, rivestite in tessuto, pelle o ecopelle.

Seat collection with a lacquered steel frame, with fabric, leather or eco-leather upholstery.



EQ Sky Bar, Kuala Lumpur, Malesia



Hotel Perles du Saveurs, Strasburgo, Francia



Dols, Belgio

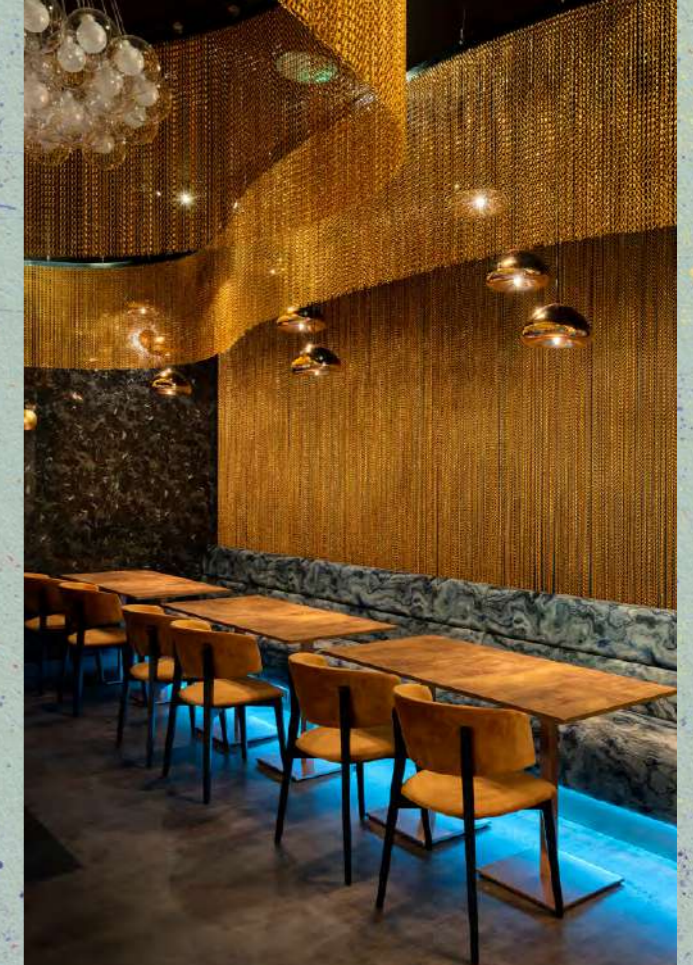

Rox Cocktail bar Club, Londra

Wround

design Copiosa lab

Una collezione di sedute dalle linee morbide e fresche, in grado di donare carattere ad ogni ambiente inserendosi con naturalezza nei molteplici contesti del vivere contemporaneo. La struttura in tondino d'acciaio sorregge con grazia una seduta e uno schienale dalle proporzioni accoglienti e compatte, imbottiti e rivestiti in tessuto.

A collection with a soft and fresh design, able to add personality to any location and to naturally integrate in many environments of contemporary living. The metal frame gracefully supports upholstered seat and backrest which have compact and cozy proportions.







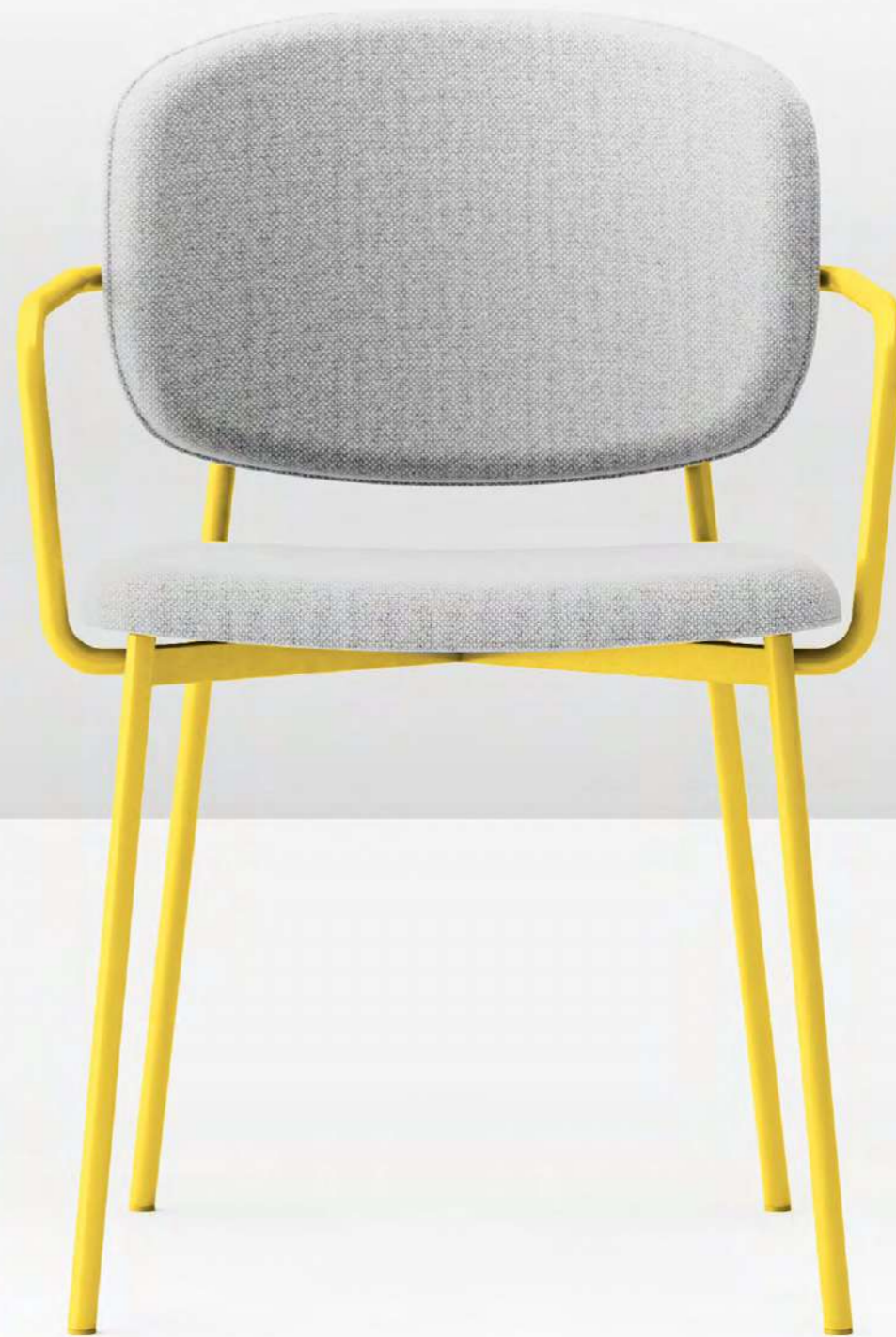
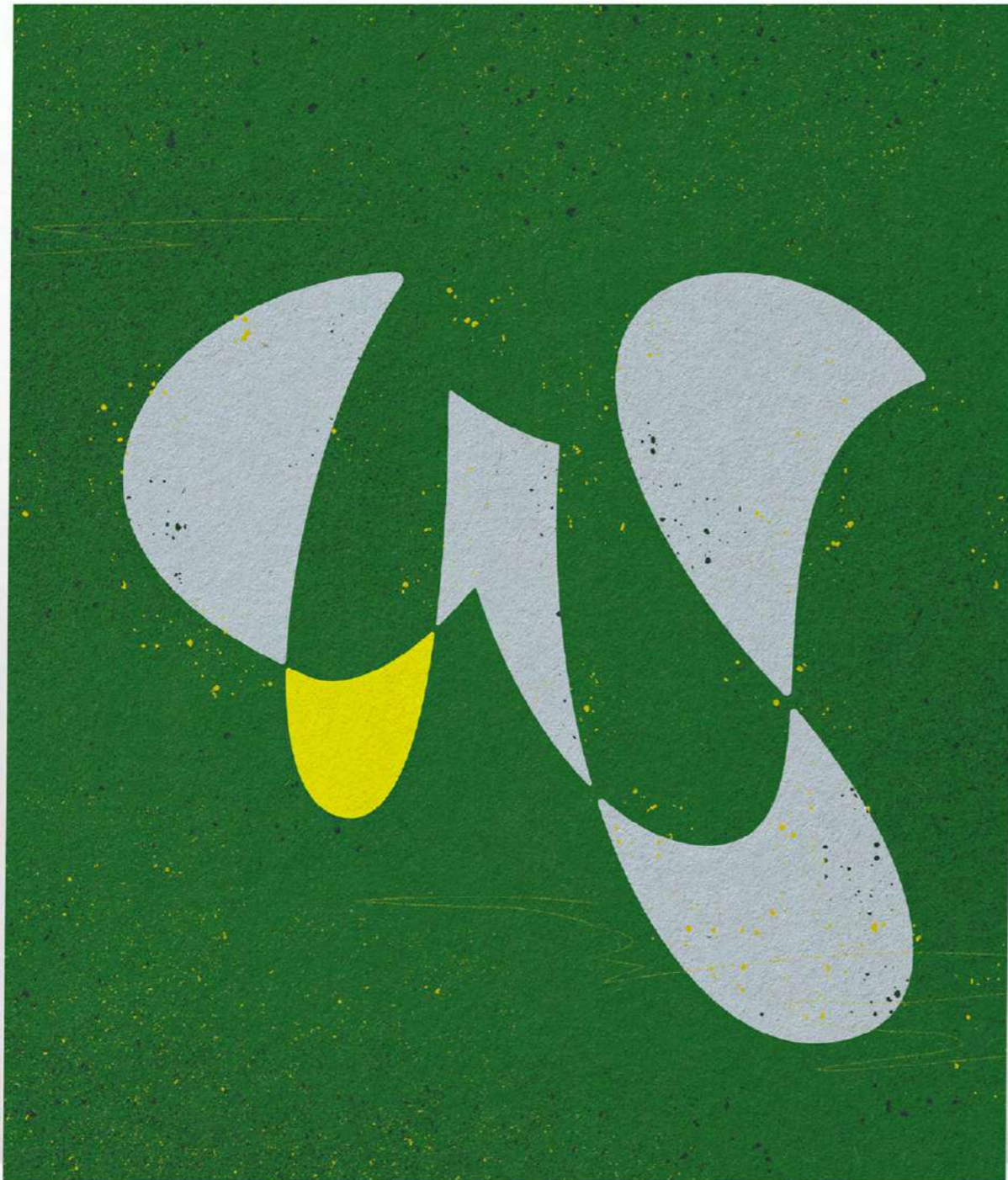

Wround

design Copiosa Lab

Sedia, sgabello, poltroncina e sedia impilabile con struttura in acciaio verniciato, rivestiti in tessuto, pelle o ecopelle.

Chair, barstool, armchair, stackable chair with lacquered steel frame and with fabric, leather or eco-leather upholstery.

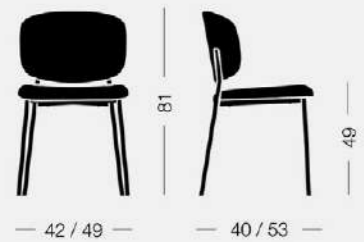

Wround 6C80 5,6 kg 0,38 m³ 2 pz

Sedia, struttura in acciaio
Chair, steel frame

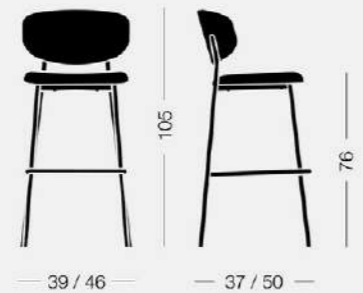

Wround 6C81 6,3 kg 0,27 m³ 1 pz

Sgabello, struttura in acciaio
Barstool, steel frame

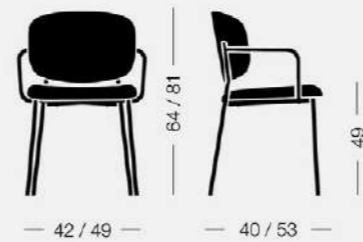

Wround 6C82 5,6 kg 0,29 m³ 1 pz

Poltroncina, struttura in acciaio
Armchair, steel frame

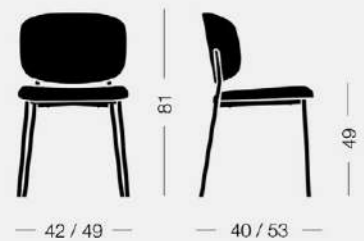

Wround 6C83 5,6 kg 0,38 m³ 2 pz

Sedia impilabile, struttura in acciaio
Stackable chair, steel frame



Finiture / Finishes

Legno - Wood

Faggio tinto — Stained Beechwood



Frassino tinto — Stained Ashwood



Legno tinto o laccato colori Collezione Copiosa — Stained or lacquered wood Copiosa collection colors

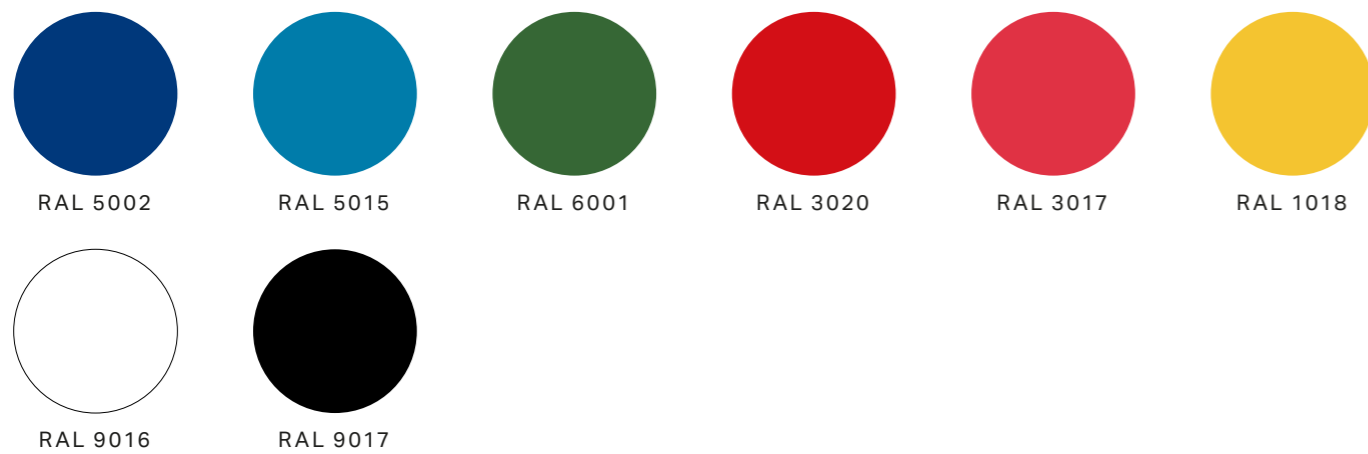

Metallo - Metal

Metallo laccato bianco e nero - Metal lacquered white or black



Metallo laccato colori Collezione Copiosa — Lacquered metal Copiosa collection colors

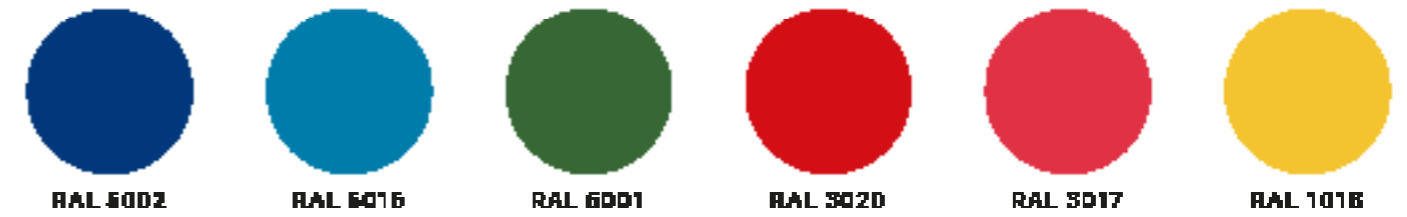

Tessuti - Fabrics

LUNA (Cat. Select)

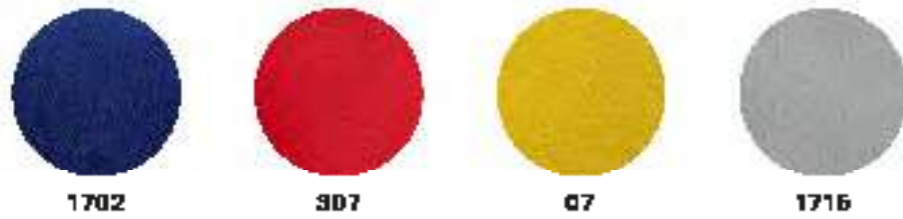

FLAMENCO (Cat. Select)



LASER N (Cat. Essential)



Ecopelle - Eco-leather

INCA (Cat. Essential)



Tessuti outdoor - Outdoor fabrics

VORTICE



KDNJAC GRISAGLIA

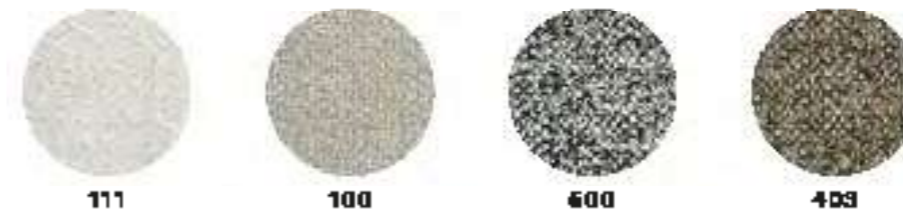

Corda - Rope

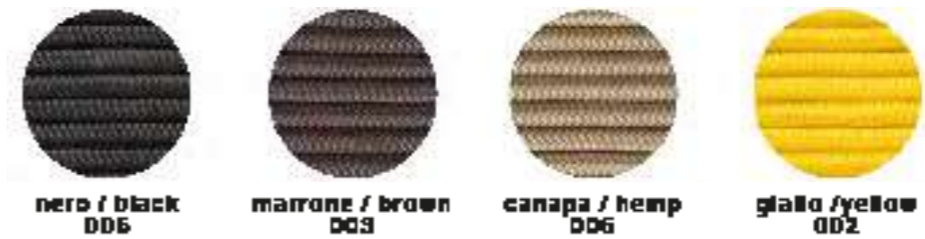

copiosa
seating for design lovers

via Udine, 20
33044 Manzano UD
Italy
info@copiosa.eu
www.copiosa.eu

