

infiniti



SIT AROUND [Y]OUR WORLD

Versable by Robin Rizzini

infiniti

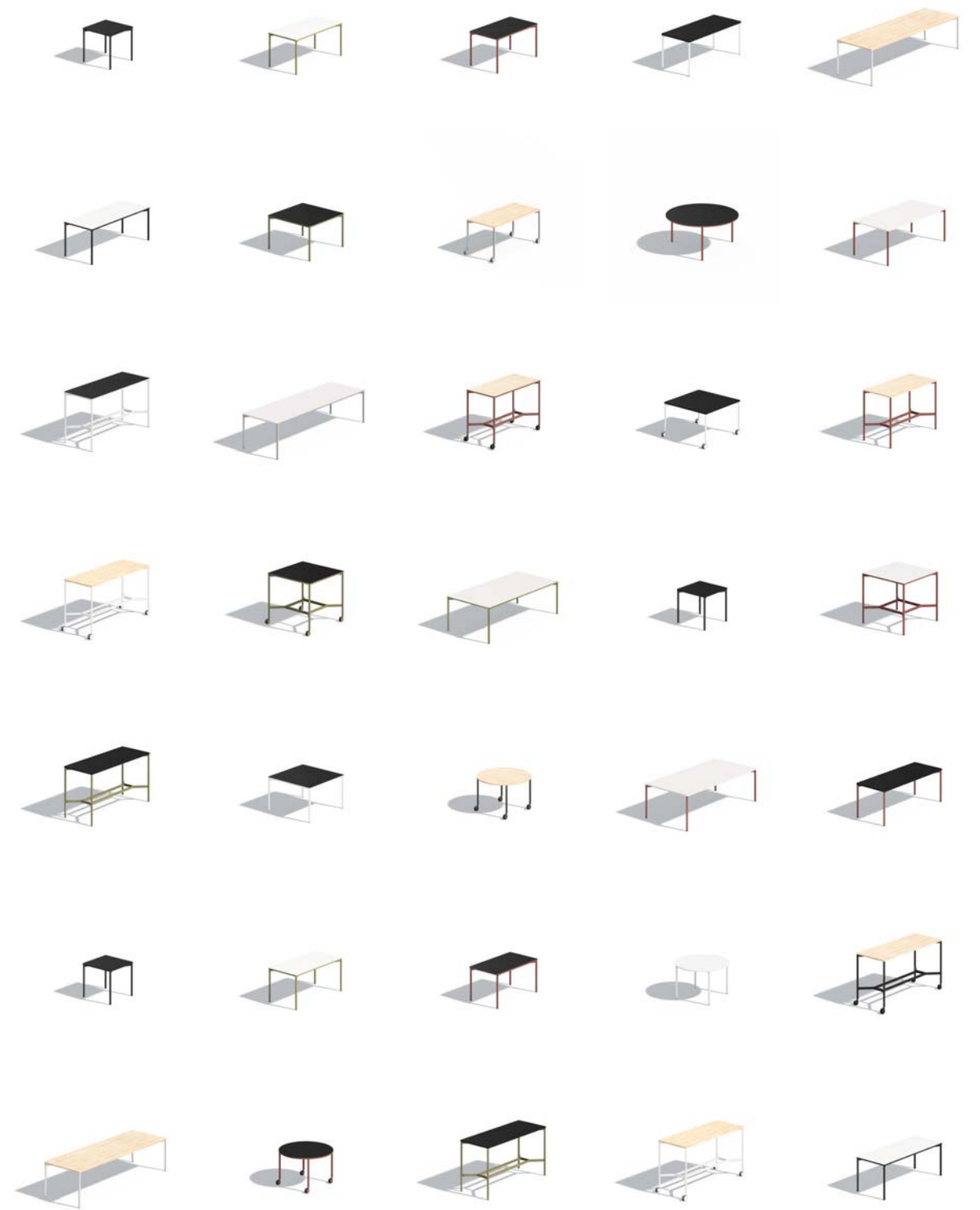

infiniti



MANIFESTO

IT - Pensiero circolare e innovazione tecnologica ci guidano ogni giorno nella creazione di complementi progettati per la vita contemporanea. I nostri arredi sono pensati per lavorare, rilassarsi e socializzare. Sedie, sgabelli, tavoli e divani della nostra collezione sanno valorizzare spazi corporate, strutture ricettive e luoghi pubblici con un design creativo e consapevole, che mette la persona e l'ambiente al centro dei processi.

EN - Circular thought and technological innovation inspire us every day as we create furniture designed for contemporary life. Our furniture is designed to be used for working, relaxing and socialising. Chairs, stools, tables and sofas from our collection add value to corporate spaces, hospitality facilities and public places through creative and mindful design that focuses on people and the environment.

DESIGNER

Robin Rizzini

IT - Designer Italo-Britannico, nasce a Genova nel 1973. Dopo una lunga esperienza nello studio di Antonio Citterio a Milano, apre il suo primo studio di progettazione nel 2006. Qualche anno dopo co-fonda ed è Design Partner dello studio Metrica a Milano. Dal 2019 torna ad essere Designer indipendente. Ha lavorato con diverse aziende dell'arredamento in Italia e all'estero lavorando su progetti destinati al mercato residenziale, contract e ufficio. Condensa il linguaggio tecnico-industriale e quello decorativo con equilibrio, con l'obiettivo di progettare oggetti e arredi essenziali, funzionali ed espressivi. Nel 2014 è stato premiato con il premio Compasso d'Oro.

EN - Italian-British Designer, he was born in Genoa in 1973. Following a consistent experience in Antonio Citterio's office in Milan he opens his first studio in 2006. After a few years he's co-founder and Design Partner of Metrica in Milan. In 2019, he's back as an independent Industrial Designer. He worked and collaborated with many companies in Italy and abroad, designing furniture for the residential, contract and office market. His main objective is to merge a technical – industrial language with a more decorative one with the aim to design essential, functional and expressive objects and furniture. In 2014 he's been awarded with the Compasso d'Oro.

[VERSABLE]

Designer interview

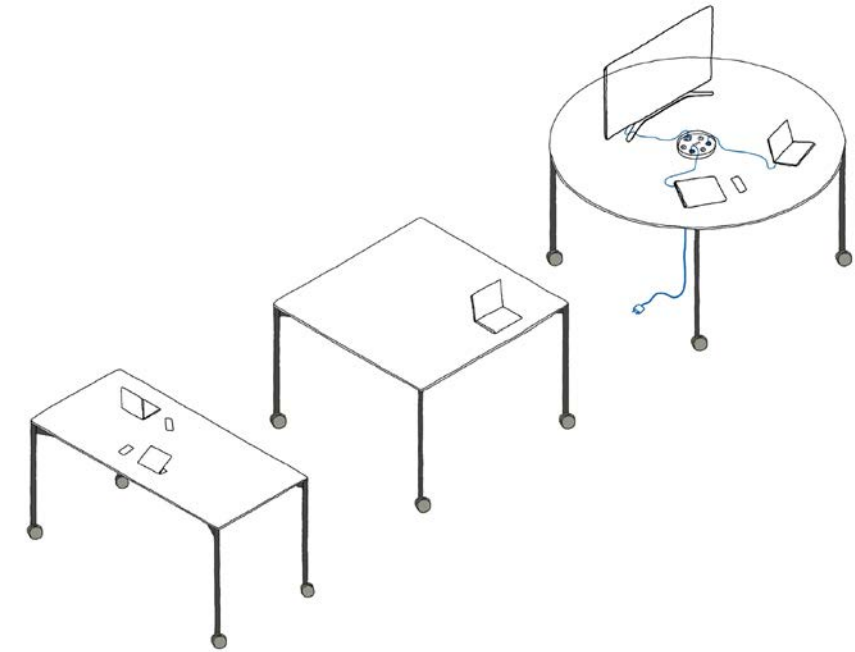

Il progetto:

IT - Qual è l'origine del nome del prodotto?

"Versable" è l'acronimo di "Versatile table" (tavolo versatile). L'idea era di trasmettere un concetto di versatilità semplice e funzionale, particolarmente adatta per lo spazio ufficio contemporaneo, che fosse la caratteristica principale del progetto.

Ricordi qualche aneddoto legato al progetto?

Beh, non so se possa essere considerato un vero e proprio aneddoto, ma la prima fase di sviluppo del prodotto si è svolta in piena pandemia. Questo ha reso le revisioni dei progetti diverse dal solito, con un approccio nuovo e inaspettato. Il secondo aggiornamento, più recente, è invece avvenuto in tempi più "normali".

Chi ti ha ispirato durante il processo creativo?

Sono un grande fan del lavoro di Richard Sapper. Anche se il suo risultato sarebbe stato probabilmente più geniale del mio, rimane uno dei miei principali riferimenti, nonostante non abbia disegnato molti mobili. È il suo linguaggio preciso che mi affascina.

Profilo personale:

Da dove vieni?

Sono nato a Genova da madre inglese e padre italiano. Mi sono trasferito a Milano intorno ai 18 anni per studiare design e da allora sono rimasto qui. Mi sento molto legato a entrambe le culture, anche se sono molto diverse tra loro.

Come descriveresti il tuo stile?

Non credo di avere uno stile preciso. Piuttosto, ho un approccio che mi porta a fare il meglio per l'azienda con cui lavoro, utilizzando la giusta quantità di materiali e cercando di inserire un tocco tecnico nel processo. Non mi considero una persona "decorativa".

Quali sono le tue fonti di ispirazione?

La buona architettura, i paesaggi mozzafiato, la buona musica e due maestri a cui penso sempre quando ho una matita in mano: Richard Sapper e Dieter Rams, per motivi diversi.

Quali sono le tue passioni?

I miei tre figli, che crescono in fretta! Inoltre, amo il tennis e la corsa. Quando posso, torno al mare genovese. Mi piace anche leggere, anche se il tempo per farlo è spesso limitato.

About the project:

EN - What is the origin of the product name?

"Versable" is an acronym for "versatile table." The idea was to convey a sense of easy versatility, designed for contemporary office spaces as the product's main feature.

Do you remember any anecdotes related to the project?

I'm not sure if this qualifies as an anecdote, but the initial development phase happened right in the middle of the pandemic, so project reviews were conducted in a new and unexpected way. The more recent update took place in more "normal" times.

Who inspired you during the creative process?

I'm a big fan of Richard Sapper's work. While his designs would undoubtedly be more ingenious than mine, he remains a key reference for me, despite not having designed much furniture. It's his precise design language that really draws me in.

Profile:

Where do you come from?

I was born in Genoa to an English mother and an Italian father. I moved to Milan around the age of 18 to study design and have stayed here ever since. I'm deeply connected to both cultures, though they are quite different from one another.

How would you describe your style?

I wouldn't say I have a specific style. I have an approach that pushes me to deliver the best results for the company I'm working with. I try to use materials efficiently and infuse a bit of technical language into the process. I certainly don't consider myself to be decorative.

What are your sources of inspiration?

Good architecture, breathtaking landscapes, great music, and two masters I always think of when I pick up a pencil: Richard Sapper and Dieter Rams, each for different reasons.

What are your passions?

My three fast-growing kids! Also: tennis and running. Whenever I have the time, I love going back to the Genoese seaside. I also enjoy reading, though time is often in short supply!

THE WORKPLACE

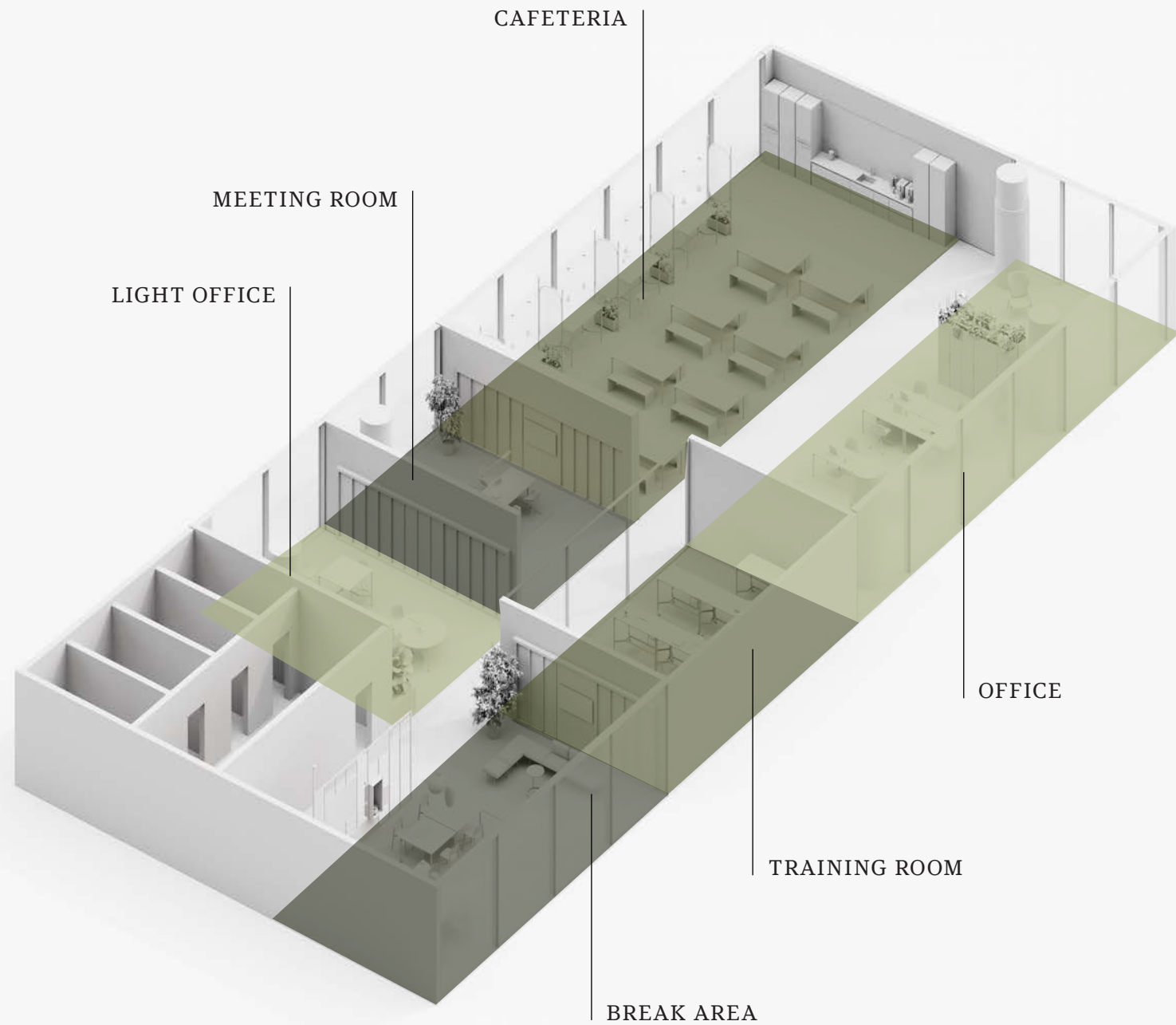

VERSABLE

[TABLE]

Design: Robin Rizzini

IT - La collezione Versable si amplia per rispondere alle esigenze dell'ufficio contemporaneo di mobilità e riconfigurabilità. La nuova gamma include tavoli da lavoro e tavoli meeting alti, aggregabili tra loro in diverse dimensioni, forme e finiture, pensati per uffici direzionali e operativi, open space, sale meeting, spazi coworking, aree relax. Ruote, elettrificazione e passacavi opzionali aiutano la produttività e il benessere.

EN - The Versable collection expands to meet the needs of contemporary offices for mobility and reconfigurability. The new range includes work desks and high meeting tables, which can be combined in various sizes, shapes, and finishes, designed for executive and operational offices, open-plan spaces, meeting rooms, coworking areas, and relaxation zones. Optional castors, electrification, and cable protector features contribute to productivity and well-being.

MEET AND DIS- CUSS



Export in 80+ countries
Born 2008
part of OMP GROUP (est. 1983)
Based in northern Italy (near Venice)
Manufacturing company
50,000 / 50,000

infiniti

PRODUCTS

[TECHNICAL DETAILS]

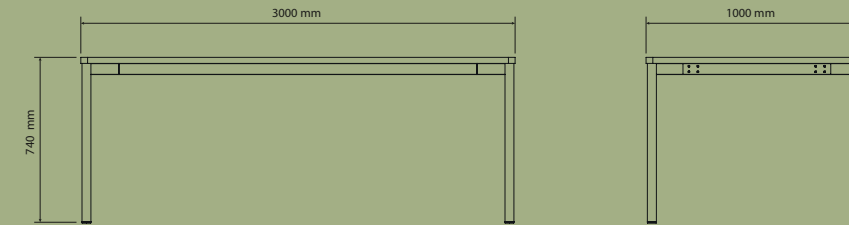

Versable

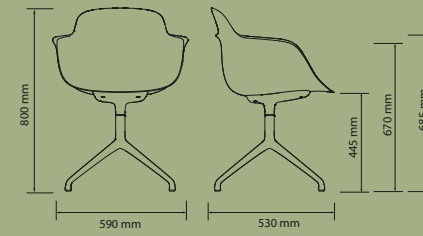

Sicla 4 star aluminium base

IT - Versable: telaio in acciaio verniciato rosso ossido fine textured 3009F, piano tavolo in laminato nero LM02, bordo in ABS rosso ossido ABS05

Sicla: monoscocca in polipropilene sabbia 514, base in alluminio verniciato sabbia fine textured 514F

EN - Versable: oxide red fine textured 3009F painted steel frame, black laminate LM02 table top, oxide red ABS05 edge

Sicla: sand 514 polypropylene monoshell, sand fine textured 514F painted aluminium base

TRAIN AND LEARN





PRODUCTS

[TECHNICAL DETAILS]

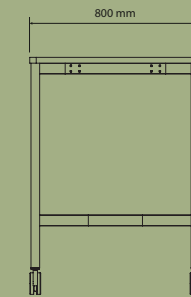
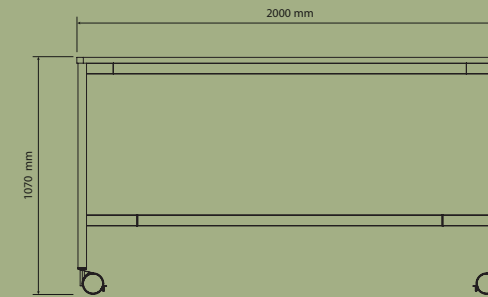

Versable Meeting

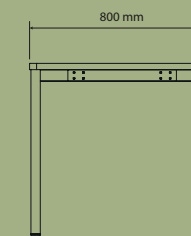
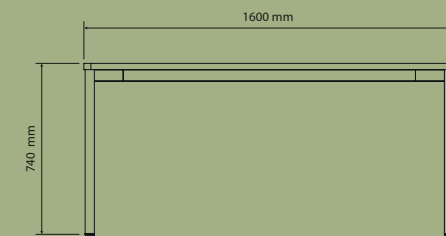

Versable

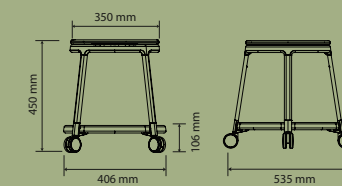

Round&Roll plastic seat - Swivel

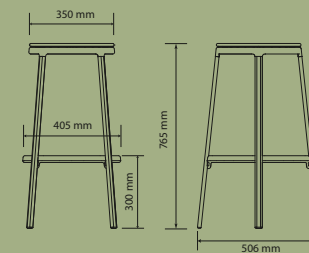

Round&Round plastic seat - Swivel

IT - Versable: telaio in acciaio verniciato verde canna 6013F, piano tavolo in laminato nero LM02
 Round&Roll: telaio in acciaio verniciato bianco gofrato 20, giallo ocra 79, rosso corallo 78; seduta in polipropilene bianco S020, giallo ocra S529, rosso corallo S527
 Round&Round: telaio in acciaio verniciato verde canna 6013F, seduta in polipropilene verde canna IR6013

EN - Versable: reed green 6013F painted steel frame, black laminate LM02 table top
 Round&Roll: embossed white 20, ochre yellow 79, coral red 78 painted steel frame; white S020, ochre yellow S529, coral red S527 polypropylene seat
 Round&Round: reed green 6013F painted steel frame, reed green IR6013 polypropylene seat

WORK AND ANALYSE





PRODUCTS

[TECHNICAL DETAILS]

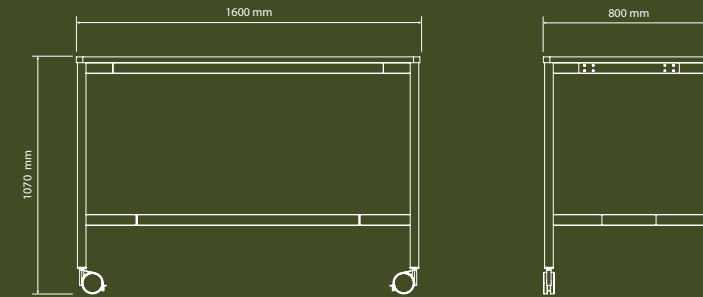

Versable Meeting

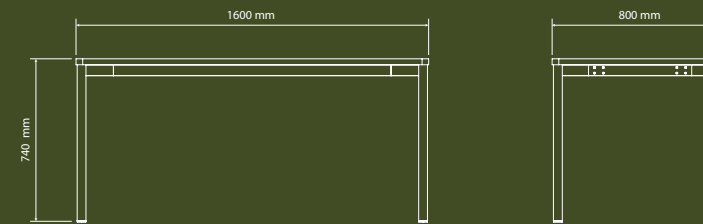

Versable

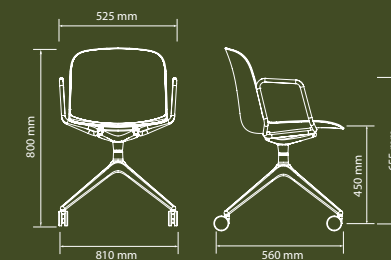

Relief swivel with castors with arms fully upholstered

IT - Versable: telaio in acciaio verniciato nero gofrato 03, piano tavolo in laminato nero LM02
 Versable Meeting: telaio in acciaio verniciato grigio 7040F, piano tavolo in laminato nero LM02
 Relief: monoscocca tappezzata con Steelcut by Kvadrat SQ434, base in alluminio verniciato nero opaco 31

EN - Versable: embossed black 03 painted steel frame, black laminate LM02 table top
 Versable Meeting: grey 7040F painted steel frame, black laminate LM02 table top
 Relief: monoshell upholstered with Steelcut by Kvadrat SQ434, matt black 31 painted aluminium base

THINK AND DREAM





PRODUCTS

[TECHNICAL DETAILS]

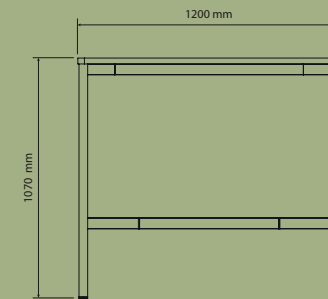

Versable Meeting

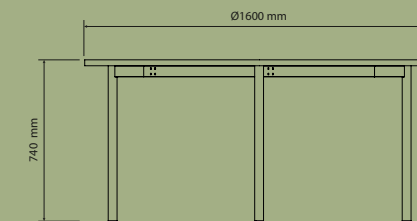
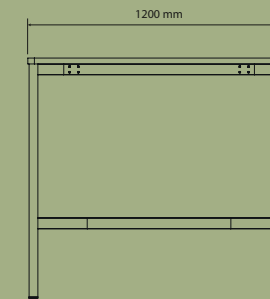

Versable Round

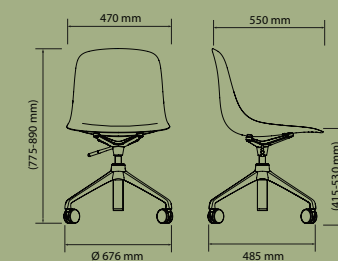

Pure Loop Mono 4 star updown upholstered seat panel



Pure Loop Mini dandy

IT - Versable Round: telaio in acciaio verniciato verde canna 6013F, piano tavolo in laminato acero LM09

Versable Meeting: telaio in acciaio verniciato verde canna 6013F, piano tavolo in laminato acero LM09

Pure Loop Mono: monoscocca in polipropilene verde canna IR6013, pannello tappezzato con Steelcut by Kvadrat SQ924, base in alluminio verniciato verde canna 6013F

Pure Loop Mini: monoscocca in polipropilene sabbia S514, telaio in acciaio verniciato sabbia fine textured 514F

EN - Versable Round: reed green 6013F painted steel frame, maple laminate LM09 table top

Versable Meeting: reed green 6013F painted steel frame, maple laminate LM09 table top

Pure Loop Mono: reed green IR6013 polypropylene monoshell, upholstered panel with Steelcut by Kvadrat SQ924, reed green 6013F painted aluminum base

Pure Loop Mini: sand S514 polypropylene monoshell, sand fine textured 514F painted steel frame

EAT AND DRINK





PRODUCTS

[TECHNICAL DETAILS]

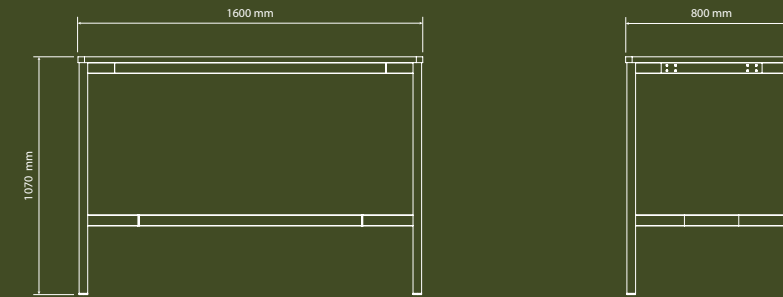

Versable Meeting

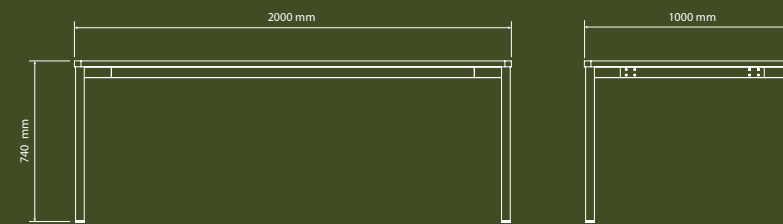

Versable

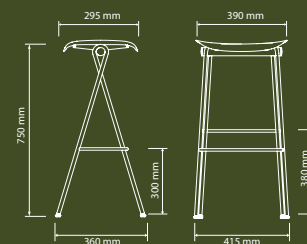

Flip bar stool plastic seat

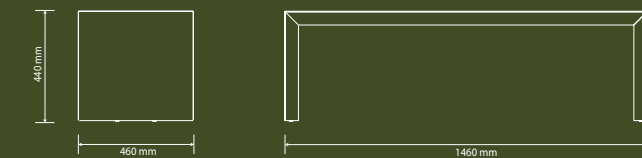

Museum 3 seats

IT - Versable: telaio in acciaio verniciato rosso ossido fine textured 3009F, piano tavolo in laminato nero LM02
 Versable Meeting: telaio in acciaio verniciato rosso ossido fine textured 3009F, piano tavolo in laminato nero LM02
 Flip: seduta in polipropilene nero carbone R8022, telaio in acciaio verniciato nero fine textured 9004F

EN - Versable: oxide red fine textured 3009F painted steel frame, black laminate LM02 table top
 Versable Meeting: oxide red fine textured 3009F painted steel frame, black laminate LM02 table top
 Flip: carbon black R8022 polypropylene seat, black fine textured 9004F painted steel frame

HAVE A BREAK



PRODUCTS

[TECHNICAL DETAILS]

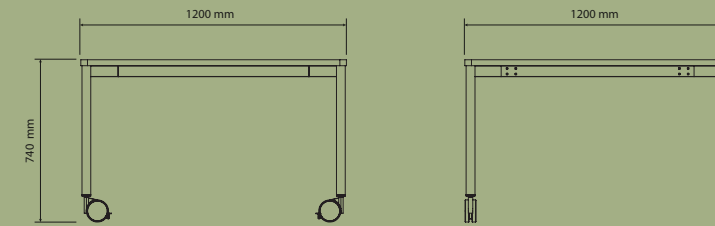

Versable Meeting

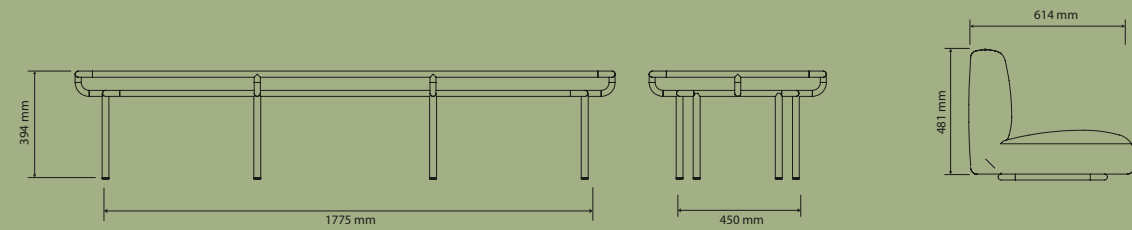

Sys

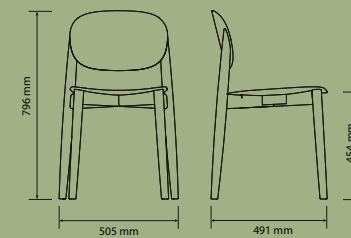

Harmo

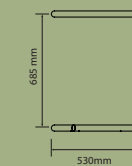

Rim: Serving tray

IT - Versable: telaio in acciaio verniciato bianco goffrato 20, piano tavolo in laminato bianco LM01

Harmo: seduta, schienale e struttura in rovere naturale ROVAN

Sys: struttura in acciaio verniciato bianco goffrato 20, modulo tavolo in laminato bianco LM01, moduli cuscini tappezzati con Oceanic by Camira OC05 e OC10

Rim: Struttura in acciaio verniciato bianco opaco 30, piano tavolo in HPL bianco HPL03

EN - Versable: embossed white 20 painted steel frame, white laminate LM01 table top

Harmo: seat, back and frame in natural oak ROVAN

Sys: embossed white 20 steel frame, white laminate LM01 table module, cushion modules upholstered with Oceanic by Camira OC05 and OC10

Rim: matt white 30 painted steel frame, white HPL HPL03 table top

VERSABLE

[TECHNICAL DETAILS]

DIMENSIONI - DIMENSIONS

Versable

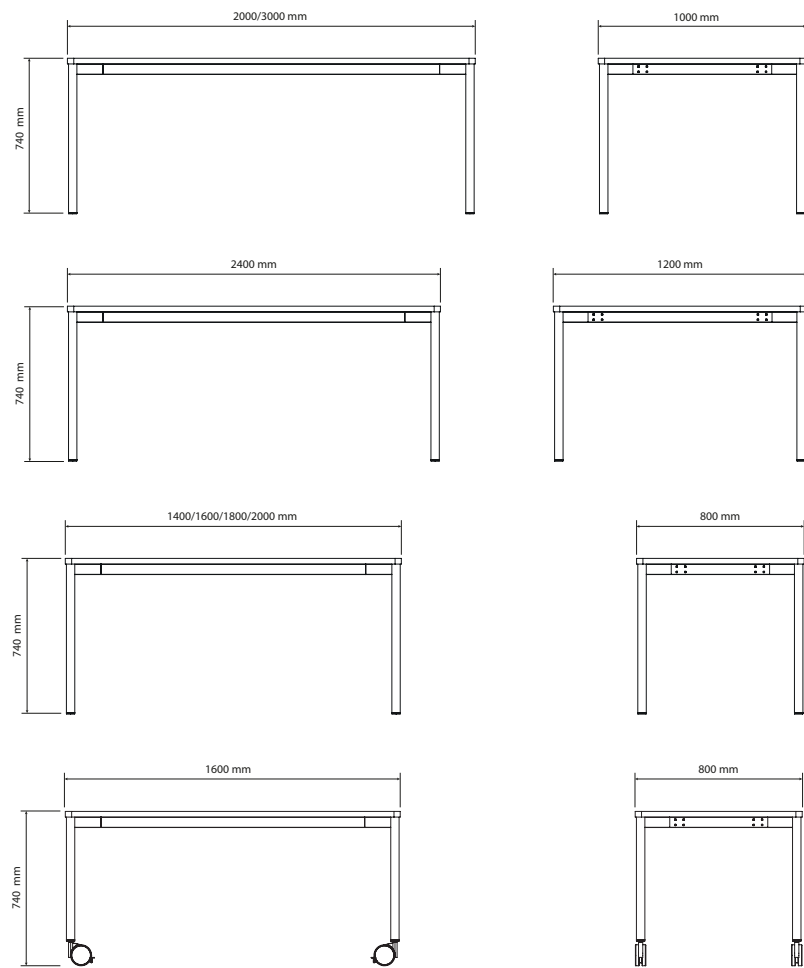

Versable Round

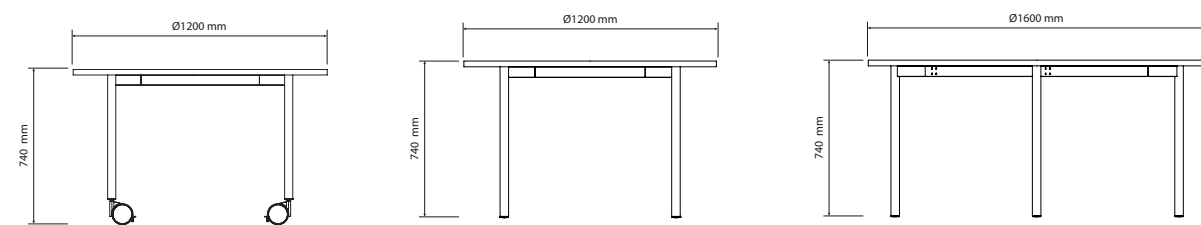

Versable Square

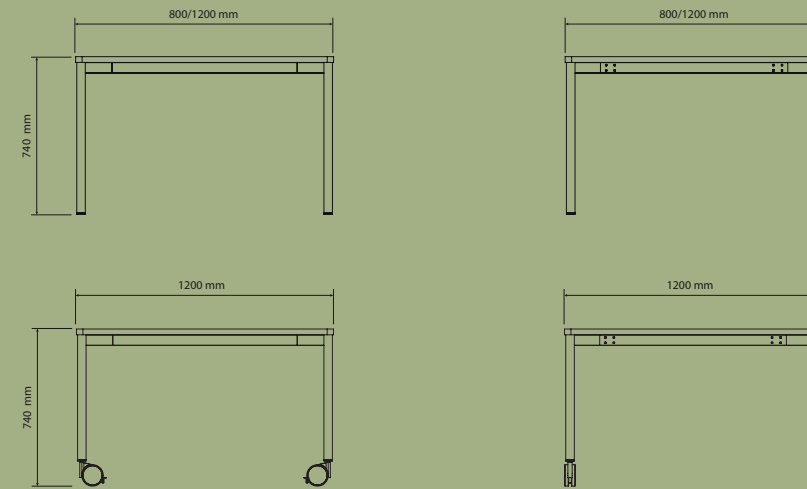

Versable Meeting

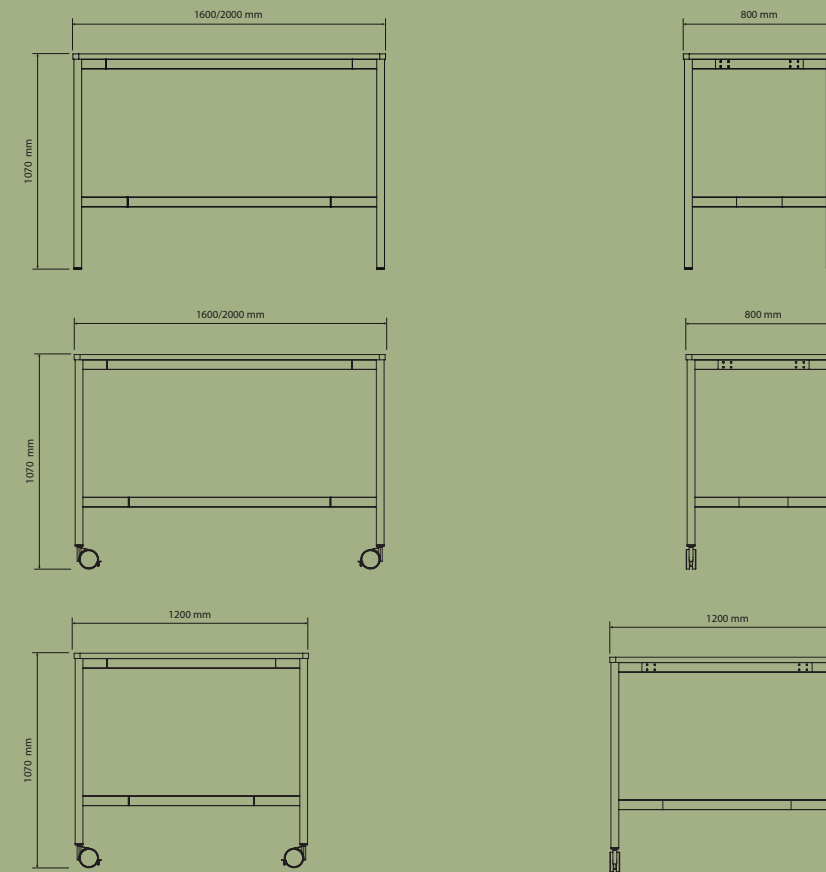

VERSABLE

[TECHNICAL DETAILS]

FINITURE - FINISHES

TELAIO METALLO - STEEL FRAME



03_nero gofrato
03_embossed black

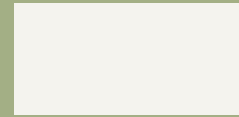

20_bianco gofrato
20_embossed white



3009F_rosso ossido
3009F_oxide red



6013F_verde canna
6013F_reed green



7040F_grigio
7040F_grey

PIANO TAVOLO LAMINATO - LAMINATED TABLE TOP

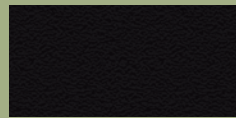

LM02_nero
LM02_black

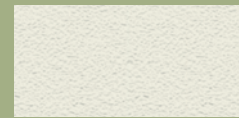

LM01_bianco
LM01_white



LM09_acero
LM09_maple

BORDO ABS - ABS EDGE (telai e bordo sempre in tinta - frame and edge always match)

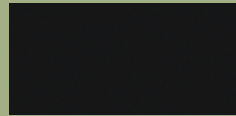

ABS02_nero
ABS02_black

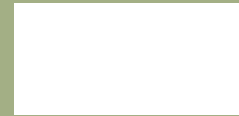

ABS01_bianco
ABS01_white



ABS05_rosso ossido
ABS05_oxide red



ABS04_verde canna
ABS04_reed green

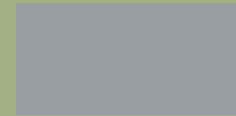

ABS07_grigio
ABS07_grey

ACCESSORI - ACCESSORIES

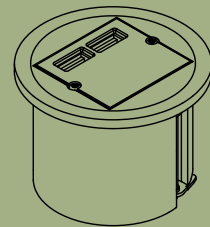

Pres a USB
USB socket

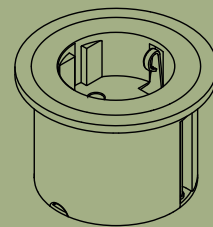

Pres a schuko
Schuko socket

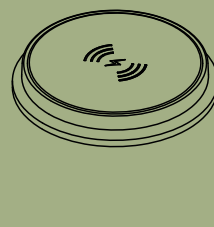

Pres a wireless
Wireless socket

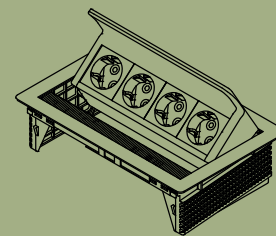

Pres a fliptop
Fliptop socket



Passacavi
Metal cable protector

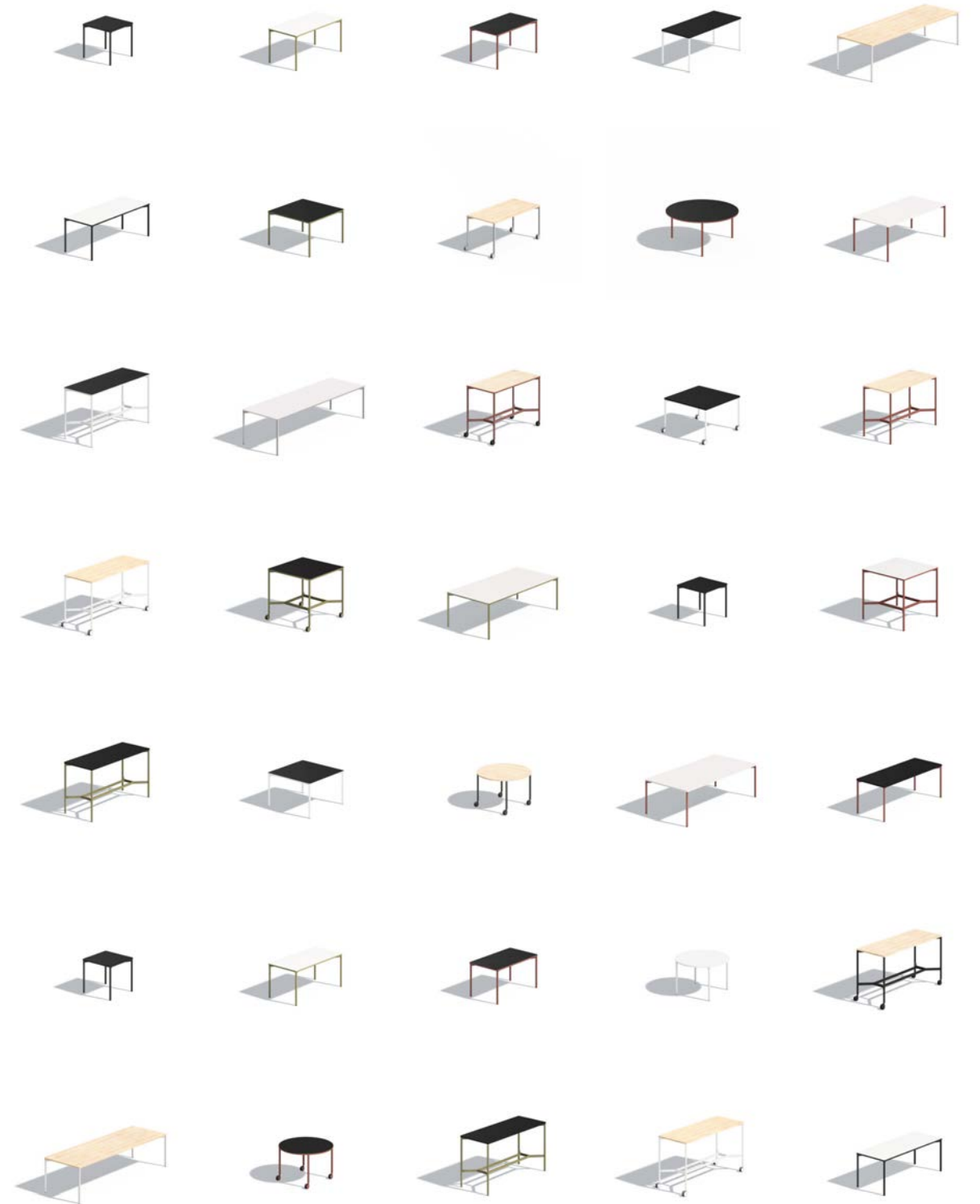

infiniti reserves the right to introduce any changes to its own models, without prior notice.

The printing ink cannot exactly reproduce the colours. For higher accuracy with suggest inspecting the colour samples.

Concept and
Art direction:

[BRUGER STUDIO]

Images:

[BRUGER STUDIO]

brugerstudio.com

Copywriting:

[VALENTINA CAVICCHIOLO]

valentinacavichio.com

Copyright:

infiniti 2024

*via Ca'Leoncino n° 2
31030 Castello di Godego
Italy*

infiniti
infinitidesign.it

infiniti