



arflex
italian design story

Products index

Sofas

9000	18
Ben Ben	6
Edo	34
Hall	30
Leenus	48
Tokio	24

Armchairs

9000	10
Botolo	52
Delta Vienna	32
Elettra	44
Hall	22
Marenco	54
Yuzu	38

Chairs

Lizzy	62
-------	----

Tables

Goya	62
------	----

Small tables

Arcolor	10
Goya	6
Scalea	6
Tablet	42
Tokio	10
Tokio open storage	15
Tokio service	44

Bookcases and sideboards

Alba	56
------	----

Accessories and complements

Match console	44
Tokio module with drawer	20
Tokio module with shelf	14
Radia	64
Radia freestanding	65



Grandi vetrate protese verso l'infinito sono le quinte che celano e svelano sia nuovi prodotti che pezzi ormai parte della collezione arflex, di design d'autore, che miscelano sapientemente segni essenziali, forme sinuose, volumi primitivi, materiali ricercati e lavorazioni artigianali.



The Lookbook



Large windows extended towards infinity are the backdrops, which conceal and reveal both new products and pieces, that are now part of arflex signature design collection, which masterfully blend essential signs, sinuous shapes, primitive volumes, refined materials and craftsmanship.

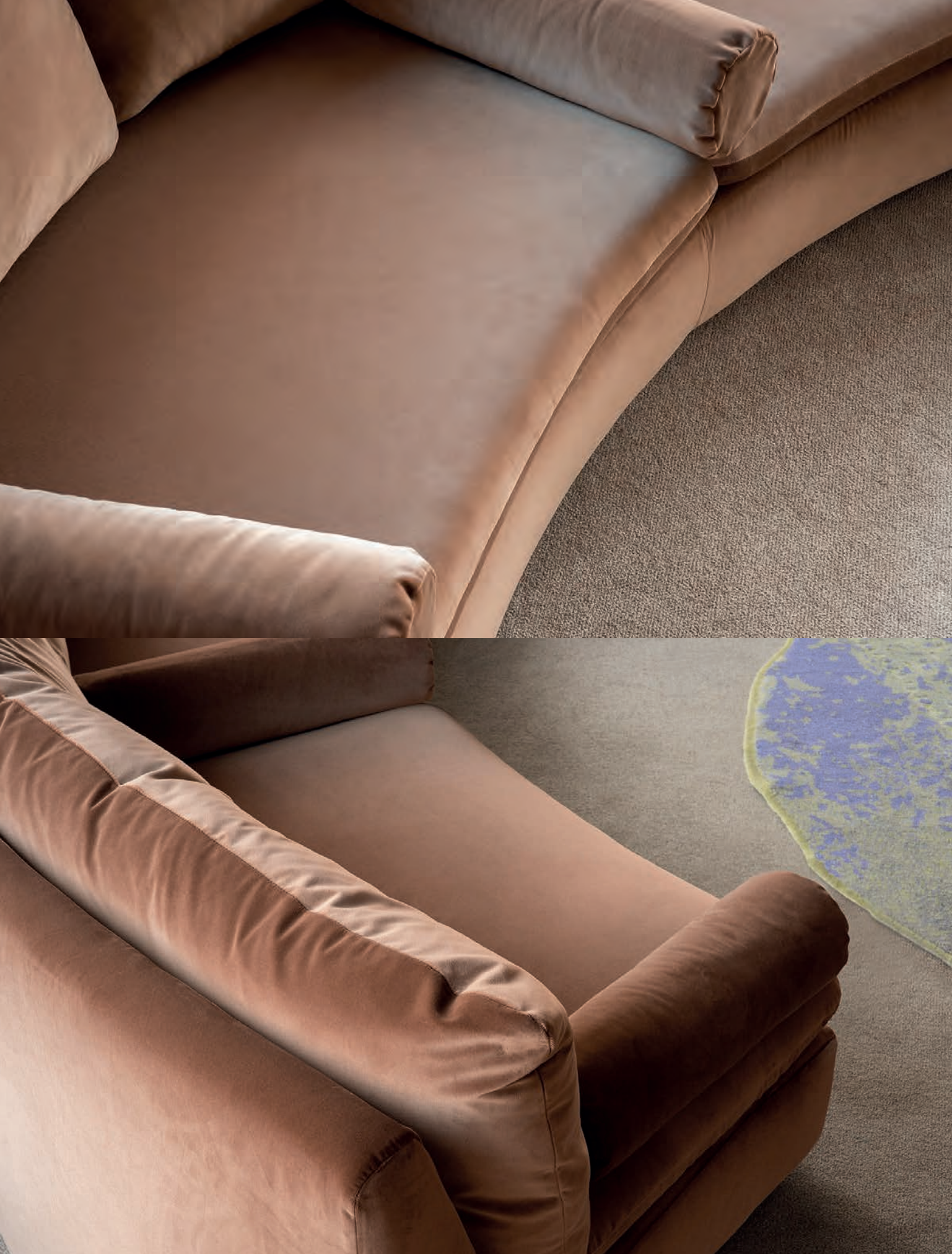

The Lookbook

Il set scelto è un avveniristico home tour nel verde del Varesotto, un'abitazione dai volumi decisi, che si srotolano dietro un'infilata di ampie vetrate.

Una meravigliosa villa storica anni Settanta, che incanta lo sguardo, dove i pezzi di design di arflex, che la abitano, si inseguono nella promenade domestica, muovendosi nella teatralità dello spazio.

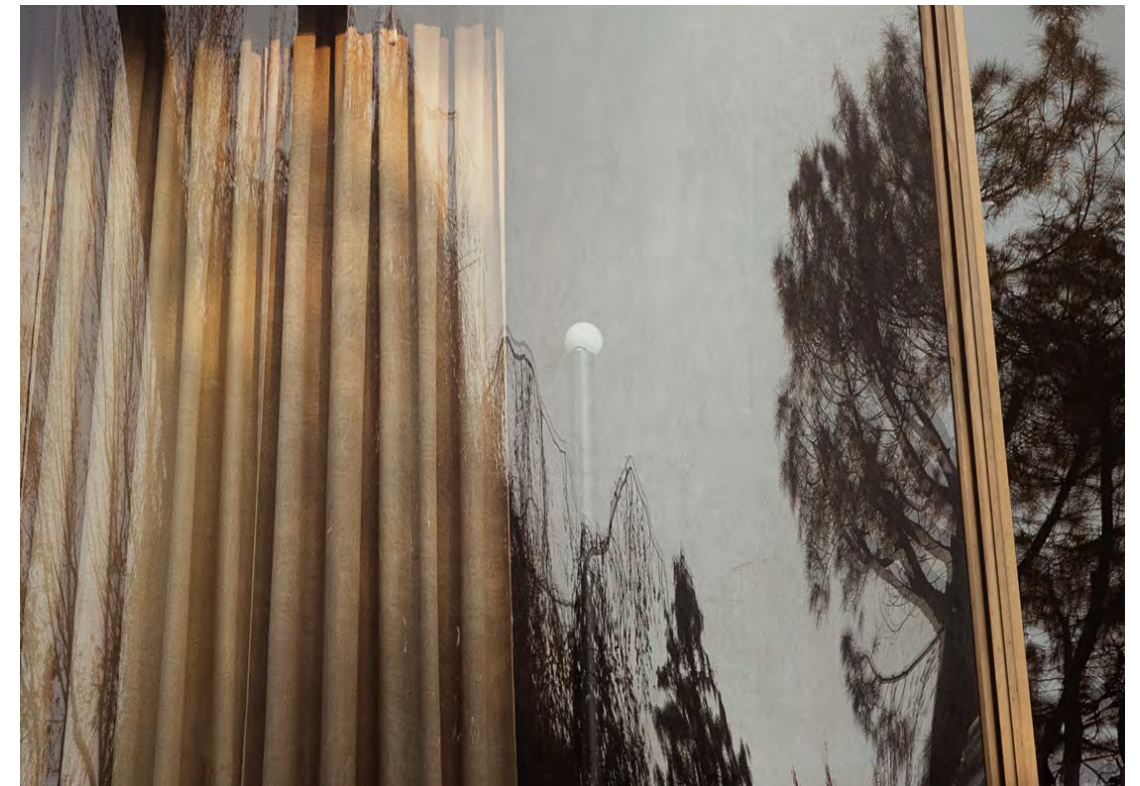

The chosen set is a futuristic home tour in the greenery of Varese area, a house with decisive volumes, that unroll behind a row of large windows. An enchanting seventies historic villa that charms the look, where arflex design pieces, that inhabit it, chase each other along the domestic promenade, moving in the theatricality of the space.

Ben Ben sofa composition B 6, Delta Vienna armchair, Goya small table, Scalea small table.





Ben Ben sofa composition B 6, Hall sofa – capsule collection Riga 002 category T6, Goya small table, Scalea small table, Delta Vienna armchair.





Tokio sofa composition T 16, 9000 armchair, Tokio module with shelf, Tokio open storage module, Tokio small table, Arcolor small table.



Tokio sofa composition T 16, 9000 armchair, Tokio small table, Tokio module with shelf, Tokio open storage module, Arcolor small table.



Tokio module with shelf.



Tokio open storage module.

Tokio sofa composition T 17/B, Tokio module with shelf, Tokio open storage module, Tokio module with drawer, 9000 sofa.





9000 sofa.



The Lookbook

Tokio module with drawer.



Tokio sofa composition T 17 / B, Tokio module with shelf, Tokio open storage module, Tokio module with drawer, Hall armchair – capsule collection Traccia category T5.

Tokio sofa composition T 17, Tokio module with shelf, Tokio module with drawer, Hall armchair – capsule collection Traccia category T5, Scalea small table.





Hall armchair – capsule collection Traccia category T5.



Il sistema di sedute **TOKIO** è stato ampliato con nuovi elementi di seduta curvi, provvisti di schienale, disponibili in diverse profondità, oltre ad altri elementi arrotondati. Le sedute curve consentono di creare divani ampi e curvilinei o composizioni ad angolo aperto. In questo modo, si offrono ulteriori soluzioni per estendere le estremità delle composizioni, in modo aperto e invitante.

L'inclusione di questi nuovi elementi rende ora possibile la creazione di tutte le combinazioni immaginabili e consente di realizzare soluzioni di seduta morbide e architettoniche all'interno degli spazi. Essi permettono, inoltre, a Tokio di essere utilizzato in modo invitante e rilassato, sia sui suoi elementi che intorno ad essi, migliorando la vita in modo vibrante e cool. I tavolini e contenitori Tokio rendono la collezione ancora più completa e flessibile.



Tokio sofa
composition T 24.

Tokio sofa composition T 30,
Tokio open storage module.



Tokio sofa composition T 22,
Tokio module with drawer.



Tokio sofa composition T 20,
Tokio open storage module.

The Lookbook

The **TOKIO** sofa system has now been expanded to include new curved seat elements, with corresponding backrest elements, are available in selected depths, as well as other rounded elements. The curved seats allow for the creation of large, sweeping curved sofas, or other open-angled sofas. The other rounded elements are intended to offer solutions to extend the ends of sofa configurations in an open and inviting manner. The inclusion of these new elements now makes almost every imaginable sofa combination possible and allow the manifestation of powerful, architectural soft seating solutions within interior spaces. Furthermore, they allow Tokio to invite a relaxed use and behaviour on and around them, making for a vibrant and cool enhancement for life. Tokio small tables and modules make the collection even more complete and flexible.



Tokio sofa composition T 25,
Tokio open storage module.

The Lookbook



Tokio sofa
composition T 26.



Hall sofa – capsule collection Riga 002 category T6, Delta Vienna armchair, Scalea small table.





Delta Vienna armchair.

The Lookbook

Il nuovo sistema di sedute **EDO**, progettato dallo studio di architettura svedese Claesson Koivisto Rune, si ricollega alla collezione Tokio, per quanto riguarda le dimensioni e la gamma completa di elementi, oltre a mantenere l'espressione morbida ma architettonica. Edo offre un altro tipo di soluzione per il design della seduta, separando il cuscino dalla base. Mentre l'espressione generale è quella di un'unica forma di seduta complessiva, la costruzione interna è stata riprogettata, per raggiungere un grado di comfort sempre più elevato.

Anche il sistema di sedute Edo, come il modello Tokio, prende il nome dalla capitale del Giappone del XVII secolo. I giapponesi hanno storicamente utilizzato forme più morbide e organiche nei loro giardini, nel design industriale e nell'architettura. Di solito si riferiscono al tocco tattile di un oggetto arrotondato. Abbiamo quindi pensato che fosse un nome appropriato per la collezione Edo.



Edo sofa composition E 32,
Tokio service.

The Lookbook

Edo sofa composition E 33,
Tokio module with shelf.



The Lookbook



Edo sofa composition E 24/B, Tokio open storage module.



Edo sofa composition E 24/C, Tokio open storage module.



Edo sofa composition E 24/D, Tokio module with shelf.

The Lookbook

The new **EDO** sofa system, designed by the Swedish architectural studio Claesson Koivisto Rune, is related to the Tokio sofa system in terms of general dimensions and the full range of elements as well as retaining the softened yet architectural expression. The new Edo sofa system offers another type of solution for the seat design, separating the seat cushion from the seat base. While the general expression is of a single overall seat shape, the inner construction has been completely reengineered, to be able to reach an ever higher degree of comfort. The Edo sofa system, like the related Tokio design, also takes its name from the 17th century name for the capital of Japan. The Japanese have historically used softer and more organic forms in their gardens, industrial design and architecture. Usually referring to the tactile touch of a rounded object. We therefore thought it would be a fitting name for the Edo collection.



Edo sofa composition E 30, Tokio open storage module.

The Lookbook



The Lookbook

Yuzu is a small - but very comfortable - armchair with a big personality. Design-wise iconic, and looking slightly like a small and cute animal, or maybe even a fictional Japanese Pokemon character. The organic and softly rounded design of the Yuzu armchair combines the Italian luxury design heritage from historical Italian brand arflex, with a Scandinavian contemporary touch signed by the Swedish architectural studio Claesson Koivisto Rune, collaborators with arflex since more than a decade.

The Yuzu armchair with its high degree of comfort, can be used in a large variety of furnishing situations. From a classical interior to the most contemporary room, the Yuzu armchair will always fit in, due to its friendly design character.

Yuzu is named after the Japanese citrus fruit Yuzu, until fairly recently unobtainable in Europe, but today a staple in contemporary high-level restaurant cuisine. It tastes somewhat like a cross between a grapefruit and a mandarin orange.





Yuzu è una poltrona piccola, ma molto comoda, con una grande personalità. Iconica dal punto di vista del design, assomiglia un po' a un piccolo e simpatico animale, o forse a un personaggio immaginario dei Pokemon giapponesi.

Il design organico e morbidamente arrotondato della poltrona Yuzu combina l'eredità del design di lusso italiano dello storico marchio italiano arflex, con un tocco contemporaneo scandinavo firmato dallo studio di architettura svedese Claesson Koivisto Rune, che collabora con arflex da oltre un decennio.



La poltrona Yuzu, con il suo elevato grado di comfort, può essere utilizzata in una grande varietà di situazioni d'arredo. Da un interno classico alla stanza più contemporanea, la poltrona Yuzu si adatta sempre, grazie al suo amichevole carattere progettuale. Yuzu prende il nome dall'agrume giapponese Yuzu, fino a poco tempo fa introvabile in Europa, ma oggi punto fermo della cucina contemporanea di alto livello. Il suo sapore somiglia ad un incrocio tra un pompelmo e un mandarancio.

The Lookbook



The Lookbook

Leenus sofa, Tablet small table.





Leenus sofa composition LU 05, Elettra armchair – capsule collection Mosso category Leather “N”, Match console, Tablet small table, Tokio service.



Leenus sofa composition LU 05, Match console, Tablet small table,
Tokio service.



The Lookbook

Il sistema di sedute Leenus è l'ultimo nato della famiglia Lee e Low Land, progettate dall'Arch. Ballardini, per permettere un alto potenziale di progettualità, oltre a molte possibilità di combinazioni, per rispondere ai vari gusti stilistici dello spazio living. Leenus ha un aspetto accattivante, generoso e confortevole, grazie al gioco di sovrapposizione dei cuscini di schienale e ai diversi moduli combinabili tra loro, che permettono di realizzare composizioni con un elegante movimento di volumi.

Leenus sofa composition LU 06/B.



Leenus sofa composition LU 06.





Leenus sofa, Tokio module with shelf.



Leenus seating system is the latest addition to Lee and Low Land family, designed by the architect Ballardini, in order to allow a high potential design, as well as many combination possibilities, to meet the various stylistic tastes of the living space.

Leenus has an appealing, generous and comfortable look, thanks to the play of overlapping back cushions and the different modules, that can be combined each other, allowing for compositions with an elegant movement of volumes.



Bracciolo stretto
Thin armrest



Bracciolo standard
Standard armrest

Leenus sofa composition LU 02, Tokio module with shelf, Tokio small table, Tokio service, Marenco armchair, Botolo armchair – capsule collection Tiger.





Marenco armchair.

Alba si arricchisce di una nuova versione fissata a parete mediante perni in ottone satinato, di ripiani in alluminio anodizzato satinato, nella dimensione di 90 cm, e due nuovi accessori: il ring contenitore e il fermalibri in ottone satinato.

Il ring contenitore è composto da un anello sostenuto da cilindretti realizzati su misura. L'altro complemento è il fermalibri, costituito da piccoli cilindri che reggono in modo elegante i libri.

La libreria Alba è disponibile sia a soffitto che a parete. I diversi materiali dei ripiani la rendono molto versatile e permette molteplici configurazioni per gli ambienti domestici, dall'area living all'home-office.



The Lookbook

Alba is enriched with a new wall-fixed version through satin-finished brass pins, satin-finish anodised aluminium shelves, in the 90 cm size, and two new accessories: the storage ring and the satin-finish brass bookend.

The storage ring consists of a circle supported by custom-made cylinders. The other complement is the bookend, composed by small cylinders, that hold in an elegant way the books.

Alba bookcase is available both with ceiling fixing and wall fixing. The different materials of the shelves make it so versatile and allow many configurations for domestic environments, from living areas to home-offices.







Lizzy chair.

The Lookbook

“Le radici sono solide, racchiudono forza ed essenzialità. Gli steli e le foglie giocano tra di loro sfiorandosi per poi prendere direzioni diverse.”

Nella sedia Lizzy è forte il richiamo a strutture e andamenti tipici del mondo vegetale. Il progetto nasce con una forte vocazione sostenibile. È una delle poche sedie presenti sul mercato realizzata con l'utilizzo di soli 7 elementi unici di massello, più la seduta in multistrato curvato.

La particolare costruzione della sedia, con le 4 gambe che si innestano singolarmente nello schienale in massello, ne aumenta la resistenza dell'intera struttura, permettendo così una riduzione delle sezioni e quindi un minor impiego di materiale.

L'utilizzo della curvatura al vapore del legno, come principale tecnologia impiegata per la realizzazione del prodotto, consente di ridurre al minimo gli sfridi di legno massello. La struttura è in legno massello curvato di frassino, mentre la seduta è in multistrato di faggio placcato frassino. Era inevitabile che Lizzy, nata di puro legno, si vestisse un giorno dei magnifici tessuti che rappresentano l'anima di arflex. Viene aggiunta, così, la versione della sedia con la seduta imbottita, ad aumentarne ulteriormente il comfort.



The Lookbook

The roots are solid, enclosing strength and essentiality. Stems and leaves are playing and brushing against one another to then take different directions.”

In the Lizzy chair there is a strong reference to structures and trends typical of the natural world.

The project was born with a strong sustainable vocation. It is one of the few chairs on the market made with the use of only 7 unique elements of solid wood, with an additional element of the seat constructed in curved plywood.

The unique construction of the chair, with the 4 legs that are grafted individually in the solid wood backrest, increases the strength of the entire structure, allowing a reduction of sections and therefore less use of material. The use of steam bending of the wood, as the main technique applied for the creation of the product, results in the minimization of the waste of solid wood.

The structure is in solid bended Ash, while the seat is in multilayer beech plated Ash.

It was inevitable that Lizzy, born of pure wood, would one day dress in the magnificent fabrics that represent the soul of arflex. And so an upholstered version of the chair comes to life, further elevating its comfort.



Lizzy chair, Goya table.

The Lookbook

Radia è l'espressione della forza di un gesto semplice. Un oggetto magico nella sua essenzialità e al tempo stesso estremamente ricco.

Nasce da un'idea forte perché pura, che ha come punto di partenza l'arte giapponese dei kirigami di carta. Un foglio unico che attraverso una piega lineare interrotta da un foro dà vita a una superficie organica tridimensionale.

Tanto la versione a parete come quella da tavolo/appoggio sono oggetti nati per decorare, per dar vita agli ambienti, animandoli di riflessi imprevedibili in un dialogo costante con gli oggetti e l'architettura che li circonda.

Entrambi gli oggetti sono realizzati con un unico foglio di acciaio Ultra Mirror colorato con trattamento PVD. La versione a parete è caratterizzata da un'unica superficie circolare del diametro di 100 cm, mentre la versione da appoggio, dell'altezza di 50 cm, oltre al fronte in acciaio, presenta una base-contrappeso in marmo con finitura satinata opaco, il cui foro cieco può all'occorrenza diventare alloggio per una luce d'ambiente.



Radia wall hanging,
Marenco armchair.

The Lookbook

Radia freestanding.



Radia is the expression of the strength of a simple gesture. A magical object in its essentiality that is at the same time profoundly rich.

It arises from a strong and pure idea, which takes the Japanese art of kirigami paper cutting as its starting point. A single sheet of paper, through a linear fold interrupted by a hole, gives life to an organic three-dimensional surface. The wall and the table/support versions are objects designed to decorate and enliven environments with unpredictable reflections, in constant dialogue with the objects and architecture surrounding them.

Both objects are made with a single sheet of Ultra Mirror steel colored with PVD treatment. The wall version is characterized by a single circular surface with a diameter of 100cm, while the table/support version, with a height of 50 cm, has a steel front and a marble counterweight base with an opaque satin finish, whose blind hole can be used as a housing for an ambient light if needed.

EDO - TOKIO



Edo

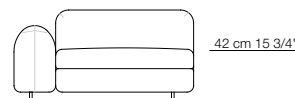

Tokio



Divani Sofas

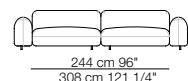
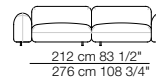
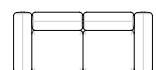
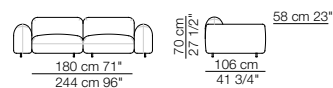

Elementi con 1 bracciolo P.106 Units with 1 armrest D.106

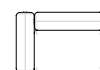
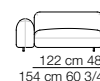
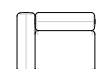
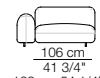
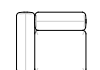
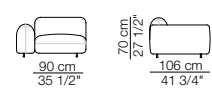

Elementi con 1 bracciolo P.122 Units with 1 armrest D.122

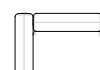
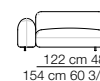
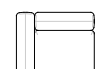
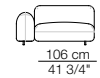
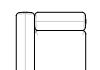
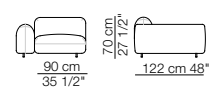

Elementi senza braccioli P.106 Units without armrests D.106

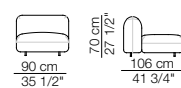

Elementi senza braccioli P.122 Units without armrests D.122

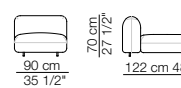

Elementi senza braccioli P.138 Units without armrests D.138

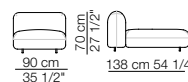

Elementi angolo P.106 Corner units D.106

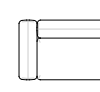
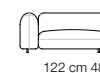
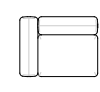
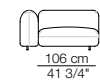
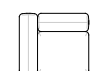
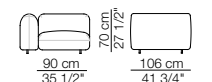

Elementi angolo P.122 Corner units D.122

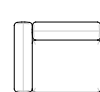
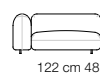
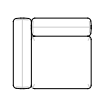
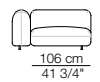
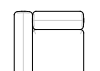
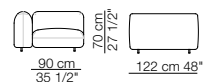

Pouf

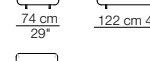
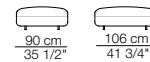
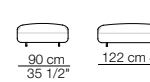
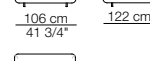
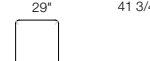
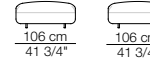
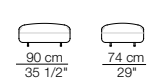

EDO - TOKIO

Divano curvo senza braccioli Curved sofa without armrests

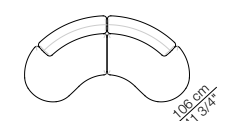
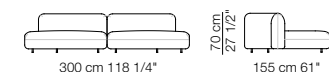

Divano curvo con 2 braccioli Curved sofa with 2 armrests

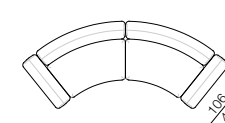
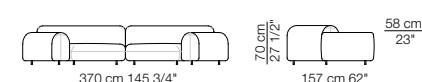

Elementi curvi con 1 bracciolo Curved units with 1 armrest

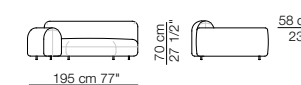

Elementi curvi senza braccioli Curved units without armrests

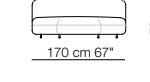
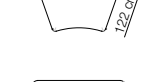
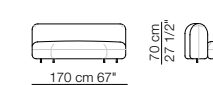
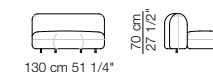

Elemento isola senza braccioli Isle unit without armrests

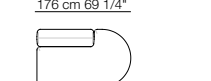
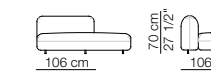

Elemento curvo isola senza braccioli Curved isle unit without armrests

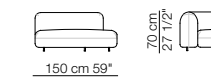

Pouf



TOKIO MODULI / MODULES



Modulo con ripiano 106 x 32 Module with shelf 106 x 32

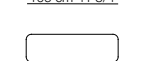
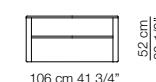

Modulo con cassetto 106 x 74 Module with drawer 106 x 74

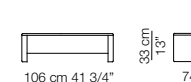

Modulo contenitore aperto 106 x 32 Open storage module 106 x 32

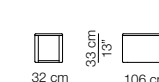

TOKIO SMALL TABLES



Service Ø 40

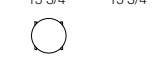
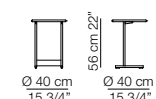

Service 106 x 32

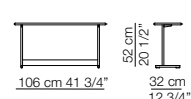

Tavolino 106 x 106 Small table 106 x 106

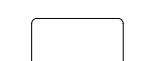
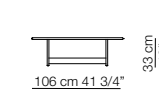

Tavolino Ø 120 Small table Ø 120

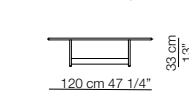

EDO - TOKIO

Esempi di composizione
Examples of compositions

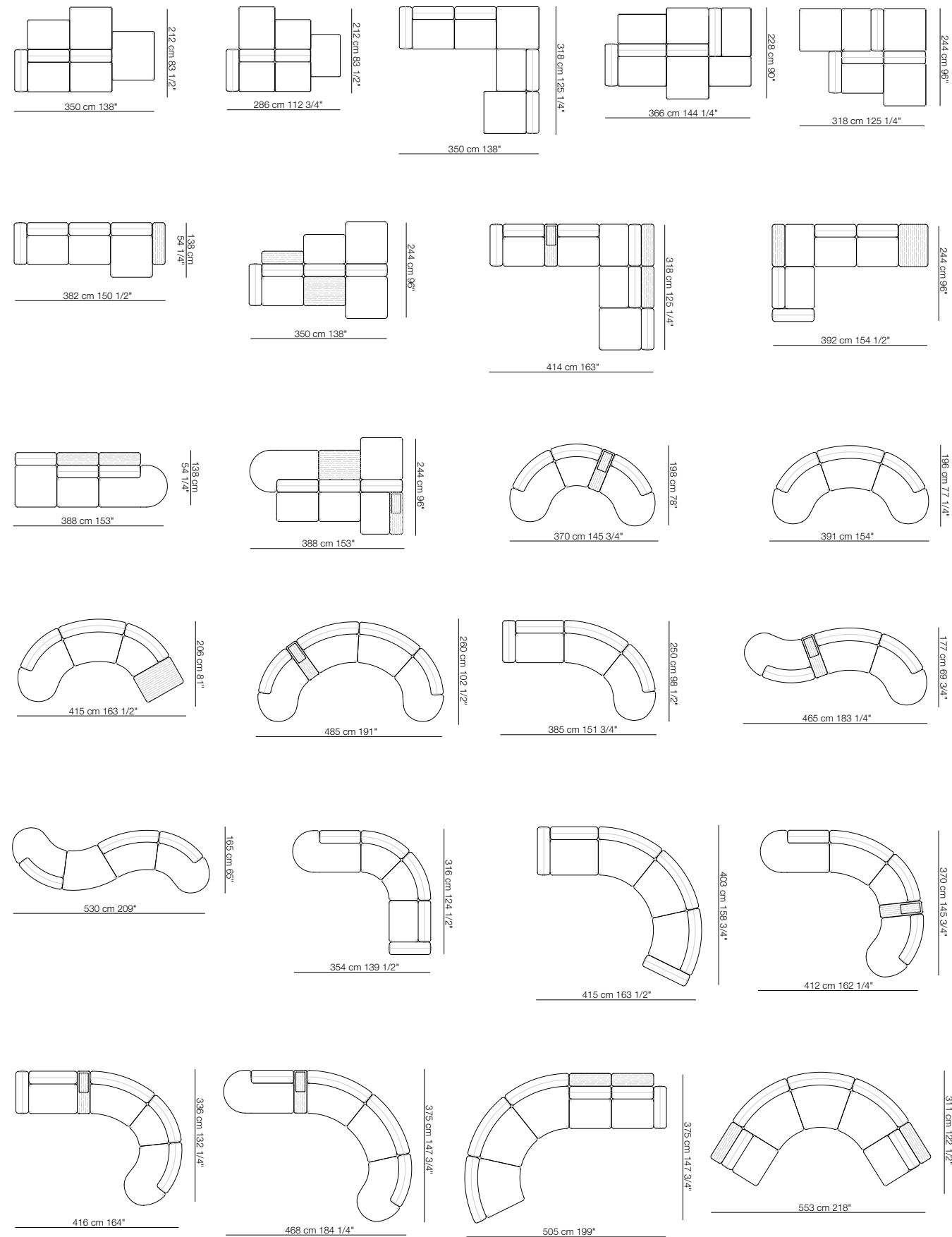

LEENUS



Bracciolo standard
Standard armrest

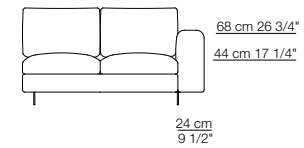

Bracciolo stretto
Thin armrest

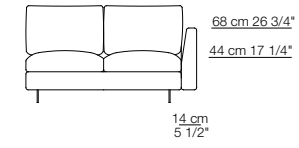

Divani
Sofas

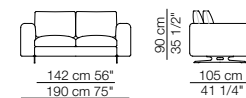

Divani con braccioli stretti
Sofas with thin armrests

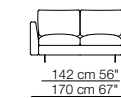

Elementi con 1 bracciolo
Units with 1 armrest

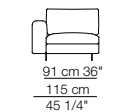

Elementi con 1 bracciolo stretto
Units with 1 thin armrest

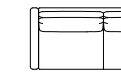
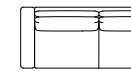
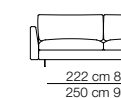
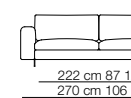
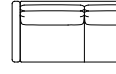
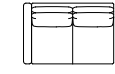
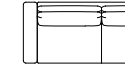
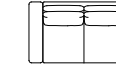
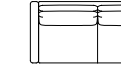
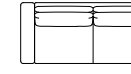
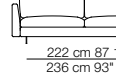
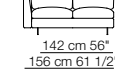
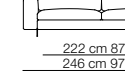
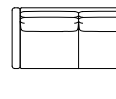
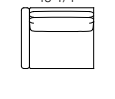
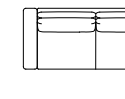
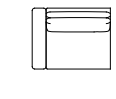
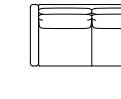
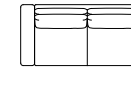
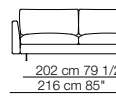
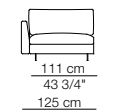
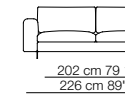
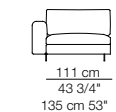
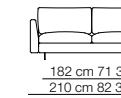
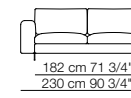
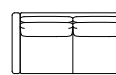
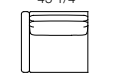
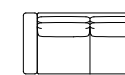
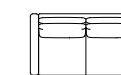
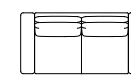
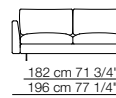
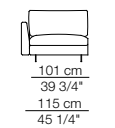
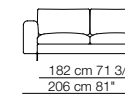
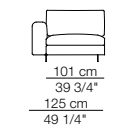
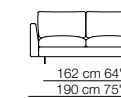
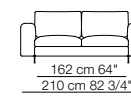
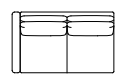
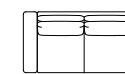
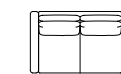
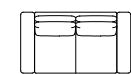
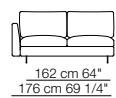
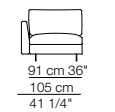

Elementi senza braccioli
Units without armrests

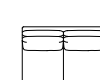
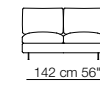
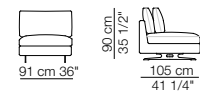

Elementi senza braccioli
Units without armrests

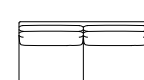
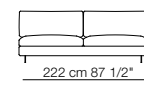
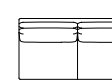
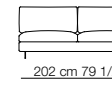
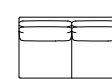
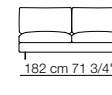
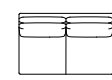
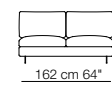

Elementi angolo
Corner units

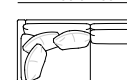
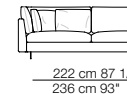
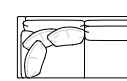
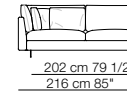
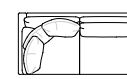
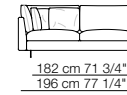
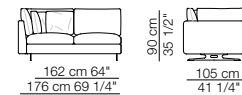

Chaise longue con 1 bracciolo
Chaise longue with 1 armrest

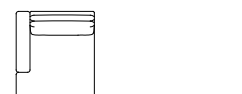
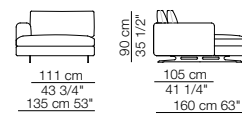

Elementi isola con angolo
Isle units with corner

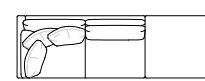
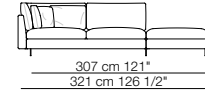
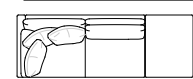
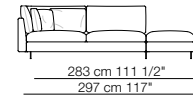
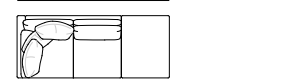
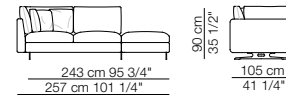

Pouf

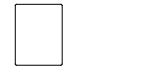
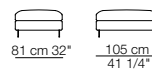

Esempi di composizione
Examples of compositions

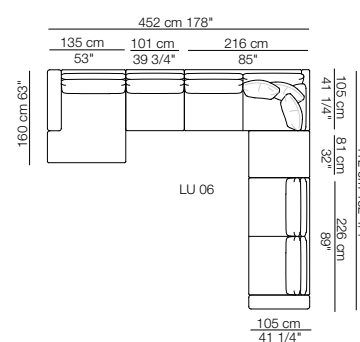
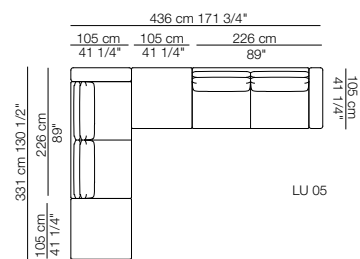
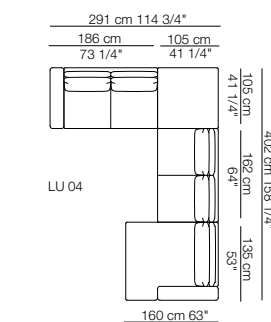
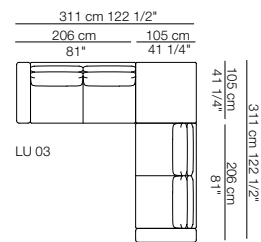
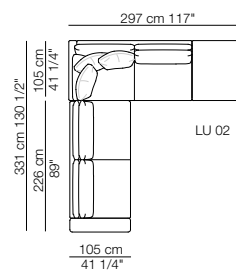
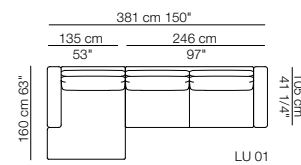

ALBA

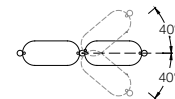

Versione fissata a parete
Wall fixing version
H. from 246 cm to 270 cm /
97" to 106 1/4"



Versione fissata a soffitto
Ceiling fixing version
H. from 240 cm to 300 cm /
94 1/2" to 118 1/4"

Composizione libreria con 2 moduli
Bookcase composition with 2 units

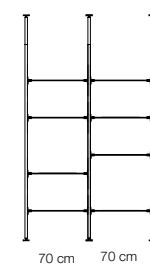

70 cm 70 cm
max. 159 cm 62 3/4"

Composizione libreria con 2 moduli
Bookcase composition with 2 units

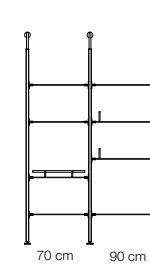

70 cm 90 cm
max. 180 cm 71"

Composizione libreria con 2 moduli
Bookcase composition with 2 units

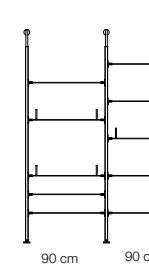

90 cm 90 cm
max. 200 cm 79"

Composizione libreria con 3 moduli
Bookcase composition with 3 units

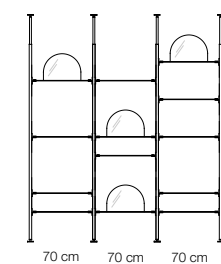

70 cm 70 cm 70 cm
max. 235 cm 92 1/2"

Composizione libreria con 3 moduli
Bookcase composition with 3 units

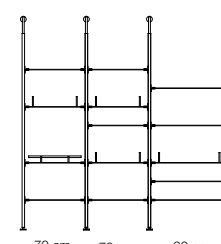

70 cm 70 cm 90 cm
max. 256 cm 101"

Composizione libreria con 3 moduli
Bookcase composition with 3 units

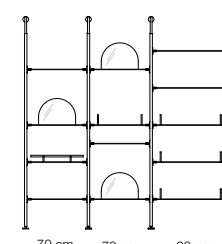

70 cm 70 cm 90 cm
max. 256 cm 101"

Composizione libreria con 4 moduli
Bookcase composition with 4 units

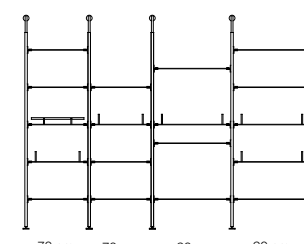

70 cm 70 cm 90 cm 90 cm
max. 352 cm 138 3/4"

Composizione libreria con 4 moduli
Bookcase composition with 4 units

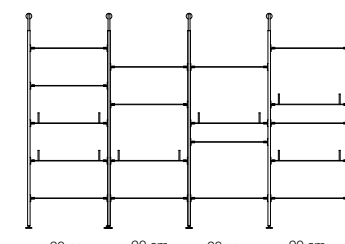

90 cm 90 cm 90 cm 90 cm
max. 392 cm 154 1/2"

YUZU

Poltrona
Armchair



LIZZY

Sedia
Chair



RADIA freestanding

Scultura decorativa da appoggio
Decorative standing sculpture

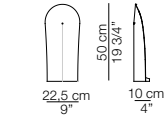

RADIA wall hanging

Scultura decorativa a parete
Decorative wall sculpture

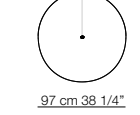

CONTACTS

arflex

via Pizzo Scalino 1
20833 Giussano (MB)
Italy
Tel +39 0362 853043
Fax +39 0362 354010
Skype : arflex design
www.arflex.com
info@arflex.it

CREDITS

Photography

IKB
Pagani Thomas

Styling

Bernhardt & Vella

Printed

April 2023

Copyright

seven salotti spa
All rights reserved 2023

Thanks to

Atelier Areti
CCtapis

I colori, le finiture, le illustrazioni e le descrizioni del presente catalogo sono a titolo indicativo e non vincolanti.

arflex, qualora ne ravvisi la necessità e per non arrestare il continuo processo di miglioramento ed aggiornamento tecnico della produzione, si riserva di apportare ai suoi prodotti, senza alcun preavviso, tutte le modifiche tecniche e strutturali che riterrà opportune.

The colours, finishing, illustrations and descriptions in this catalogue are provided solely by way of example.
arflex, if necessary and in order not to stop the continuous improvement process and updating of the technical production, reserves the rights to change its models, without giving prior notice, amending them with all the technical and structural modifications considered appropriate.

