

WE MAKE SUMMER

SCREENS





## Professional patio design – MAY-screens perfectly complement your al fresco business



An intimate environment

### Sound arguments for the use of MAY-screens

- Maximization of profit and sales as a result of more customer space.
- Longer al fresco season as customers are better sheltered from the wind and cold.
- Your patio looks neat and tidy: this way your business is visually upgraded and stands out against your neighbours.
- The screens provide ample space for individual printing motifs.
- The enclosed area is likely to attract families with small children.
- The intimate environment evokes a feeling of privacy.
- Your customers are better protected against pickpockets.



Corporate design down to the limits

### Advantages of MAY-screens

- Easy mounting of the robust screens.
- MAY-screens give a feeling of "see-and-be-seen" stylishness. You feel sheltered and, yet, have an unobstructed view.
- The mobile screen elements can easily be removed and reassembled. Thus permission from the town authorities should not be a problem.



Enclosed area

### Better turnover

Arouse attention and increase turnover with this eye-catcher. The textile panels are ideal for corporate printing. Always in direct view, your individual logo will immediately strike the eye.

We offer durable silk-screening on any colour textile as well as full-colour digital printing (only on white fabric).

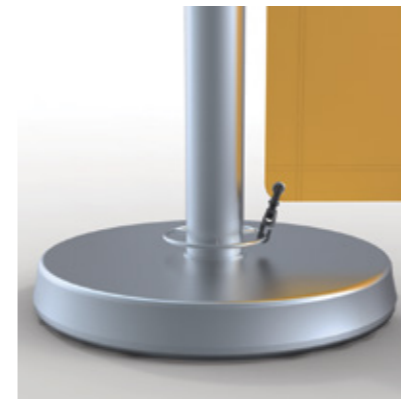

Fastening the textile panel with a hook



Rolling the base

### Uniform appearance

Corporate design begins with your company letterhead and continues on your patio. A well-thought out concept with matching or possibly the same material for your umbrellas, awnings and enclosure screens will convince your customers. Should you, at a later stage, wish to change your corporate appearance, you can bring your patio up to date simply by exchanging the textiles.

### Easy handling

MAY-screens can be mounted in just a few steps. They can easily be moved to make room for the weekly market or a special event or when a storm comes in. Just do the following: Place the crossbar in the post. Fix by turning the end cap and then fasten the textile panel with the hook at the bottom end.

### The metal components

Seawater-proof stainless steel posts manufactured in V4A (1.4401, AISI 316). The crossbar (up to 2.5 m in length) is made of aluminum and powder-coated in RAL 9006. That is, all parts are weather-resistant and rustproof. The screens can be secured against theft with the help of the special spanner supplied.

### The textiles

Choose one of our durable fabrics, developed specifically for outdoor use. We offer our textiles in a wide range of shades to enable optimal colour combinations to match the walls of your building, patio furniture and umbrellas or awnings.

### Textile options

- MayTex Acryl classic awning fabric also available for MAY sunshades
  - MayTex Mesh coarse-meshed lattice structure for transparency.
- See page 6 for details of materials and colours.

### Durability

While in use during the season MAY-screens do not require any maintenance. If the metal parts get dirty, they can be cleaned with a conventional stainless steel cleaner.

### Mobile base

With a weight of 21 kg and a diameter of 40 cm the base of the metal construction is extremely stable and sturdy. For wind-sheltered indoor areas we offer a lighter version with a base weight of 15 kg. The rim of the base is rounded off, which makes it easy to roll the post and base into the house in the evening. Or the base can be carried in. The stainless steel posts are screwed to the base. This makes it possible to remove the posts in winter and save space for storage. The bottom of the base is padded to avoid scratching the patio floor. This is particularly important for marble or granite floors.

## MAY-screens series A

Single segment with 21 kg bases

Measurements	cm
<b>a</b> post to post axis*	
<b>b</b> length of crossbar	a - 6.4
<b>c</b> length of textile panel	a - 14.4
<b>d</b> total length	a + 40
<b>e</b> base Ø	40
<b>f</b> base radius	20
<b>g</b> vertical gap	4
<b>h</b> post diameter	6.4
<b>i</b> height of post	93 / 156
<b>j</b> total height	99 / 162

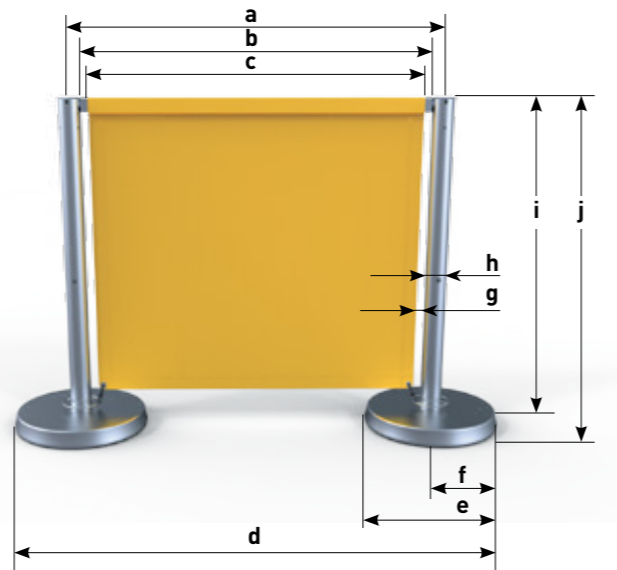

\*customized choice of length, cm gradation, min. 60 cm, max. 250 cm

## Printable surface

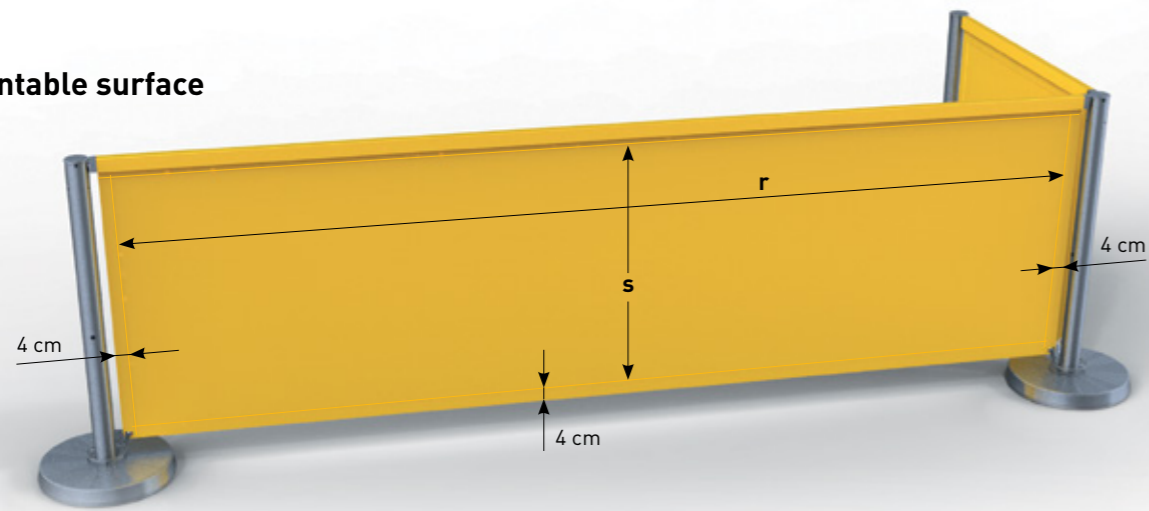

Maximum printing area	cm
<b>r</b> width	a - 22.4
<b>s</b> height	post height - 20

Digital printing only possible single-sided. If the height of the upright post is 1.56 m, a cross seam is applied 42 cm above bottom edge.

## Adjustable crossbars

Four grooves in the upright posts allow the crossbars to be positioned at an angle of 90°. In addition, the angle of the crossbars can be varied by a maximum of 20° either way. The most common ways of arranging the screens are shown under the heading "Frequently chosen patio layouts".

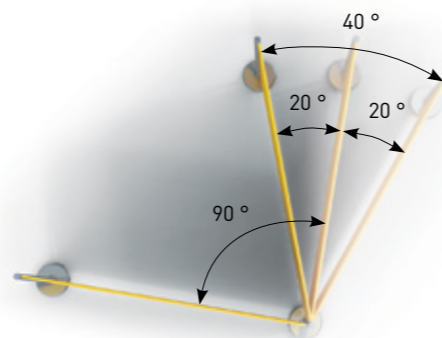

All measurements given in this brochure are to be understood as approximate figures.

## Frequently chosen patio layouts

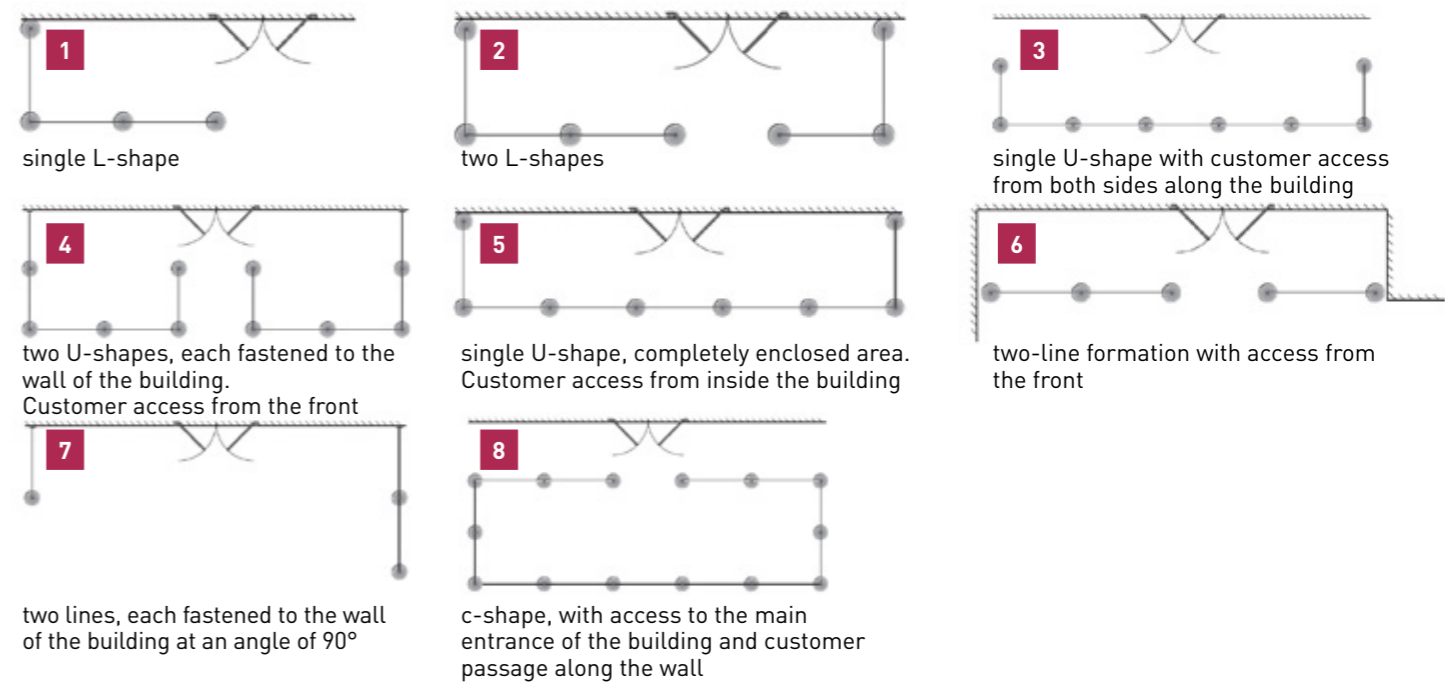

## Sample layout of patio

top view, axial dimensions

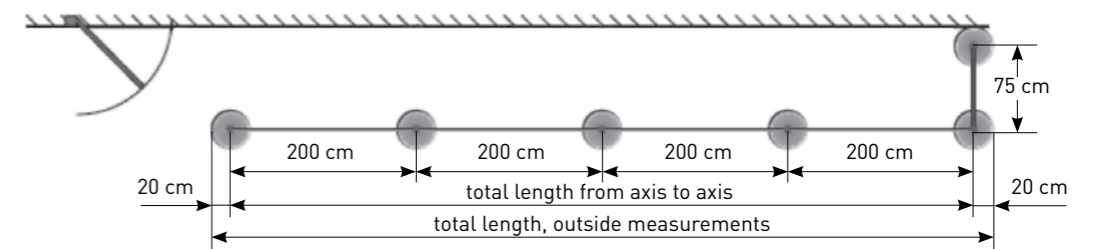

side view of printed panels

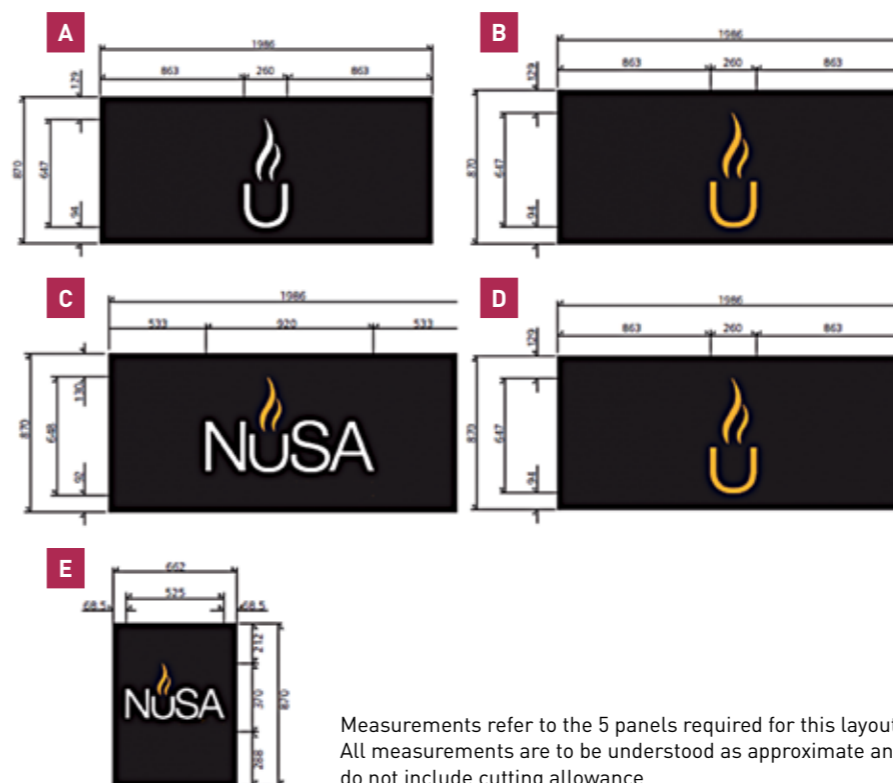

top view of printed panels

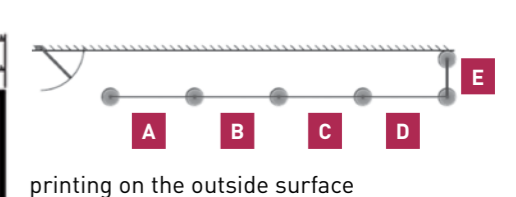

printing on the outside surface



full view of sample patio

Measurements refer to the 5 panels required for this layout. All measurements are to be understood as approximate and do not include cutting allowance.

## MayTex-Acryl with Texgard impregnation

- material: 100% polyacrylic, spun-dyed, weight 300g/m<sup>2</sup> ±5%
- water column (fabric water tightness) 370 mm, European standard EN 20 811
- colour fastness: grade ≥7 (against bleaching), tested acc. to standard EN ISO 105-B02 (1= min., 8= max.)
- colour fastness to artificial weathering: grade ≥4-5 (against bleaching), tested acc. to standard EN ISO 105-B04 (1= min., 5= max.)
- protection against UV rays: UPF 40-80, tested acc. to UV standard 801
- weather-proof, high and low temperature resistant
- Texgard impregnation gives effective protection against oil, grease, mildew and algae, industrial pollution, exhaust fumes and other negative environmental factors
- tested acc. to Öko-Tex standard 100
- imprinted ads: on parasol canopy and valance in durable, brilliant screen-printing quality
- cleaning: easy to clean with CleanoMay 13, even when mounted

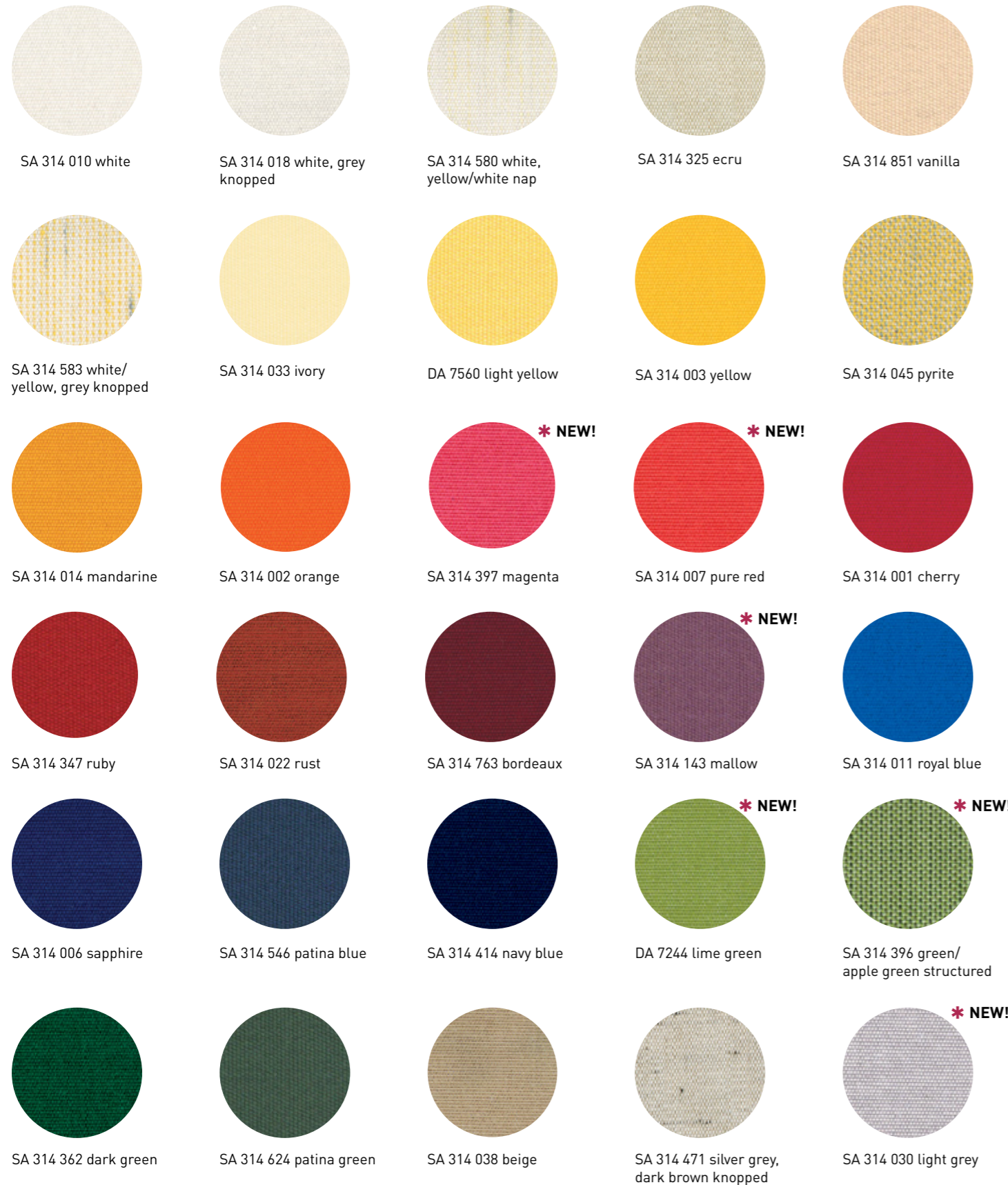

The colours printed on these pages may differ slightly from the original. On request we will send you a cloth collection with original textile samples.



## MayTex-Mesh

- polyester fabric, PVC-coated, heavy-metal and cadmium-free
- produced in accordance with The Environment Management norm DIN ISO 14001
- plain white; all other colours are printed
- fabric in mesh structure (mesh-size: approx. 1 x 1.4 mm)
- air permeability of 1800 l/m<sup>2</sup>/sec at 2mbar
- dirt and water-repellent PVC
- very good light and weather fastness (UV resistance)
- highly tear resistant (tear strength: 1300/1500 N/5 cm, acc. DIN 53354)
- low flammability acc. DIN 4102 B1 and M1; thus also suited for indoor areas

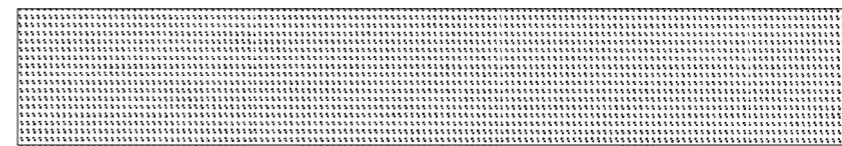

MayTex-Mesh, white



MayTex-Acryl

- weather-proof, resistant against high and low temperature extremes
- rot-resistant
- scratch-proof, dimensionally stable, easy care



MayTex-Acryl



MayTex-Mesh

## Stainless steel post

Height 93 cm, weight 2.72 kg, seawater-resistant V4A, outer  $\varnothing$  6.35 cm.

Order No. **WA0093**



## Stainless steel post

Height 156 cm, weight 4.25 kg, seawater-resistant V4A, outer  $\varnothing$  6.35 cm.

Order No. **WA0156**



## Base for indoor area

Weight 15 kg, cover of seawater-resistant V4A, outer  $\varnothing$  33 cm, height 5 cm.

Order No. **WA1015**



## Base for outdoor area

Weight 21 kg, cover of seawater-resistant V4A, outer  $\varnothing$  40 cm, height 5 cm.

Order No. **WA1021**



## Wall bracket

Needed if you wish to fasten a MAY-screen directly and flush to the house wall. As you require one postless, it is not only a practical but also a money-saving option. Moreover, your screen becomes very stable. In principle, the wall bracket can be fixed to any upright surface (brick, wood, glass etc.). Delivered without dowels.

Order No. **WA2001**

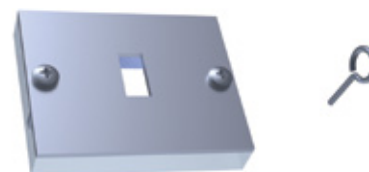

## Required Accessories

(at least 1 set necessary per patio)

### Tubular box wrench

to screw the stainless steel post to the base.

Order No. **WA9002**



### Face spanner

to turn the end cap into the stainless steel post.

Order No. **WA9003**



### Carry handle

for the stainless steel posts.

Order No. **WA9004**



### Spare parts Expanders

black, 10 per packaging unit.

Order No. **WA9001**



## MAY Gerätebau GmbH

Zum Mühlbach 1  
88422 Betzenweiler, Germany

info@may-online.com  
www.may-online.com

Management: Karl-Heinz May, Klaus-Peter May  
Amtsgericht Ulm HRB 650155