

*An iconic
design
for every
space.*



arflex
italian design story

PRODUCTS INDEX

Sofas

9000	5 - 29 - 112
Arcolor	146
Bel Air	96
Ben Ben	228
Banah	33 - 90
Bonsai	242
Claudine	272
Cousy	32 - 178
Cradle	108
Deep Cradle	110
Faubourg	298
Frame	294
Hall	191
Hollywood	236
Hug love seat	154
K2	284
Lee	126
Leenus	19
Low Land	132
Marechiaro	68
Marenco	42 - 46
Naviglio	8 - 156
Pecorelle	164
Rendez-Vous	260
Soft Beat	280
Strips	80
Tokio	246

Armchairs

Algon	232
Botolo	25 - 172
Butterfly	258
Cradle	106
Cross	196
Delfino	30 - 64
Delta Vienna	36
Elettra	22 - 60
Fiorenza	76
Giulietta	290
Gloria	138
Hall	26 - 188
Hug	150
Jules	192
Jim	194
Katrin	300
Ladle	134
Leafo	184
Marenco	54
Pecorelle	162
Serena	278
Suppli	16 - 86
Tellin	52
Virgola	58

Chairs and stools

Botolo	25 - 172
Elettra	218
Hug	155
Lizzy	38
Neptunia	214
Orfeo	222

Dormeuse and daybed

Banah	33 - 90
Bonsai	242
Cousy	179
Sigmund	204

Tables

Goya	102
Hug	208

Small tables

Arcolor	151
Bonsai	74
Capilano	266
Cradle	82
Goya	104
Infinity	12 - 149
Island	132 - 247
Match	170
Sigmund	202
Tablet	50 - 262
Tokio	250

Bookcases and sideboards

Alba	142
Match	166
Rubycon	268

Accessories and complements

Ciclope	243
Delfino pouf	241
Diva	221
Doge pouf	278
Match console	169
Papillon	66
Penta pouf	94
Ponti	224
Pouf	158
Sigmund writing desk	200
Threshold	6 - 120
Vela	176



a journey through Italy

Un grand tour romantico e incantevole, intimo e miracoloso, che porta ad una nuova interpretazione di alcuni prodotti senza tempo. Scendendo per viale delle Belle Arti a Roma, la verdeggiante arteria urbana che costeggia Villa Borghese ai margini del Giardino Zoologico, si incontrano alcuni dei più prestigiosi palazzi di nazioni straniere presenti a Roma. Stanze immaginate, grandi vetrate e colonnati protesi verso l'infinito sono le quinte, che celano e svelano sia nuovi prodotti che pezzi ormai parte della collezione di arflex, di design d'autore, che miscelano sapientemente segni essenziali, forme sinuose, volumi primitivi, materiali ricercati e lavorazioni artigianali. Design e architettura costruiscono un dialogo organico tra presente e passato, sempre orientato al domani, alla costruzione di paesaggi inediti, reali o interiori.

A romantic and enchanting grand tour, private and miraculous, leading to a new interpretation of some timeless products. Walking down Viale delle Belle Arti in Rome, the green urban artery, that runs alongside Villa Borghese at the edge of Giardino Zoologico, we meet some of the most prestigious palaces of foreign nations in Rome. Imagined rooms, large windows and arcades extended towards infinity are the backdrops, which conceal and reveal both new products and pieces, that are now part of arflex signature design collection, which masterfully blend essential signs, sinuous shapes, primitive volumes, refined materials and craftsmanship. Design and architecture build an organic dialogue between present and past, always oriented to the future, to the construction of new landscapes, real or internal.



4 / design collection

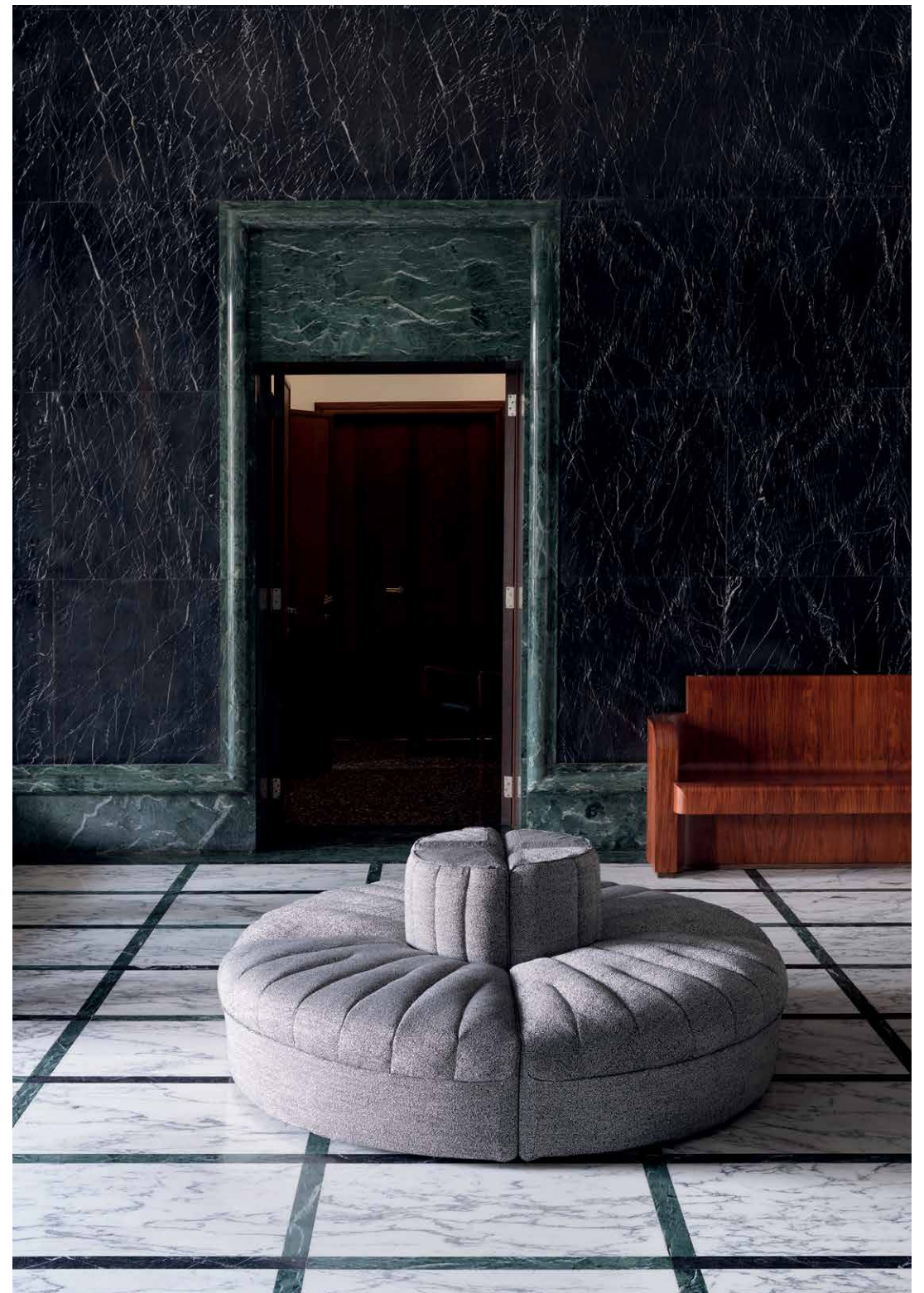

9000/sofa
composition NV 02

5 / design collection



Threshold/high
mirror cabinet

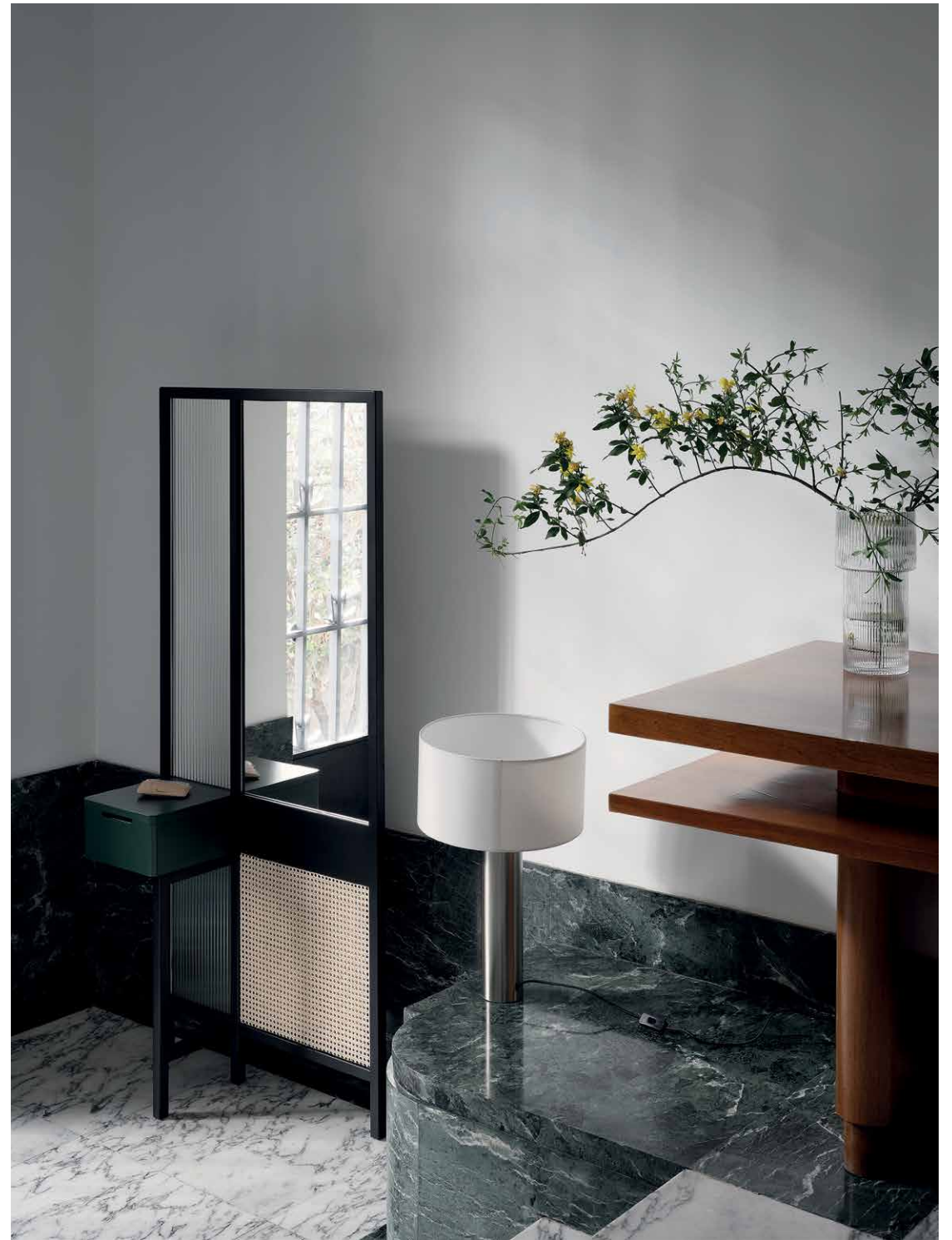



Naviglio/sofa
Tablet/small table
Botolo/armchair



Naviglio/sofa
composition N 06
Infinity/small table
Suppli/armchair



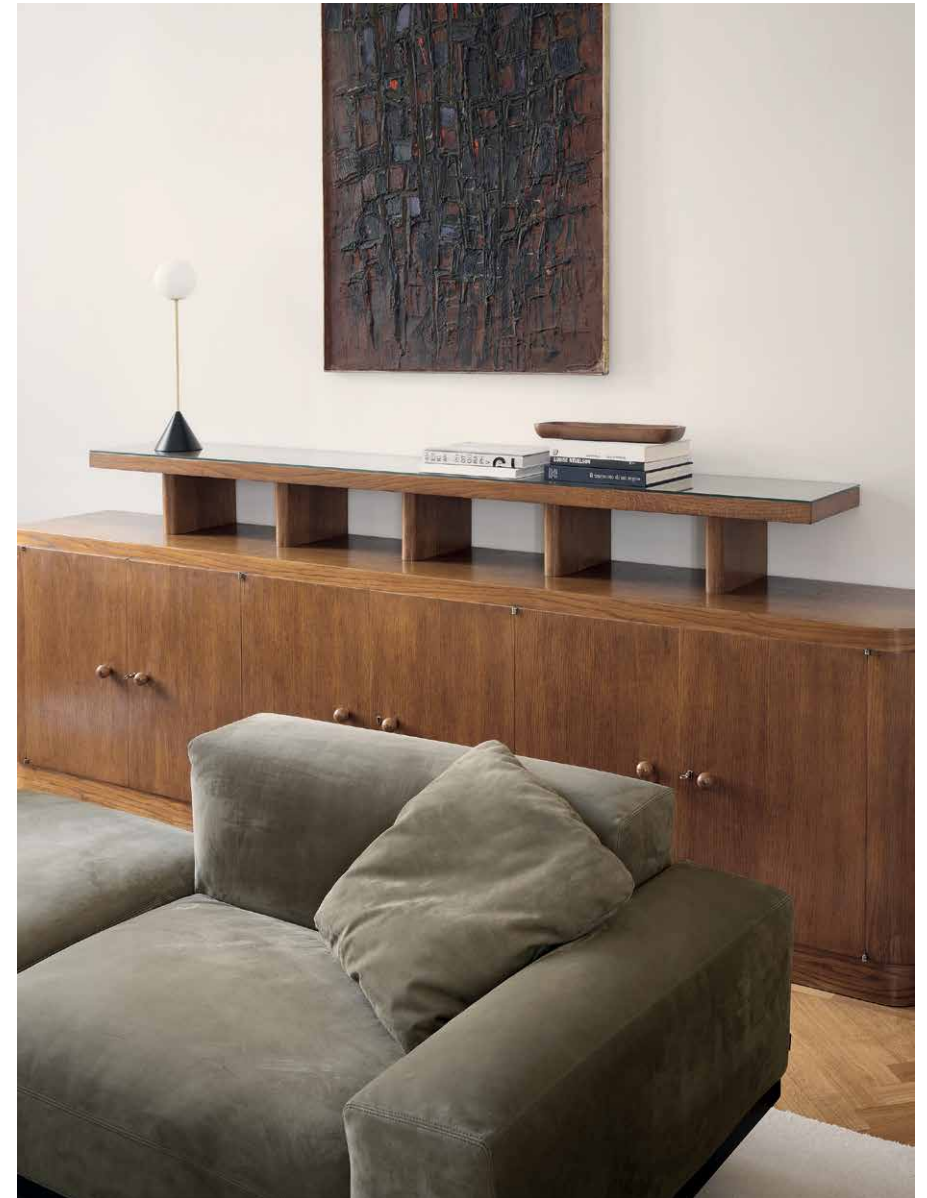

Naviglio/sofa
composition N 06



Suppli/armchair
Tablet/small table

Naviglio/sofa
composition N 06
Infinity/small table





Leenus /sofa
composition LU 05
Tablet/small table
Tokio/small table
Match/console



Leenus /sofa
composition LU 05
Elettra/armchair
Tablet/small table
Tokio/small table
Match/console



Leenus /sofa
composition LU 05
Elettra/armchair
Tablet/small table



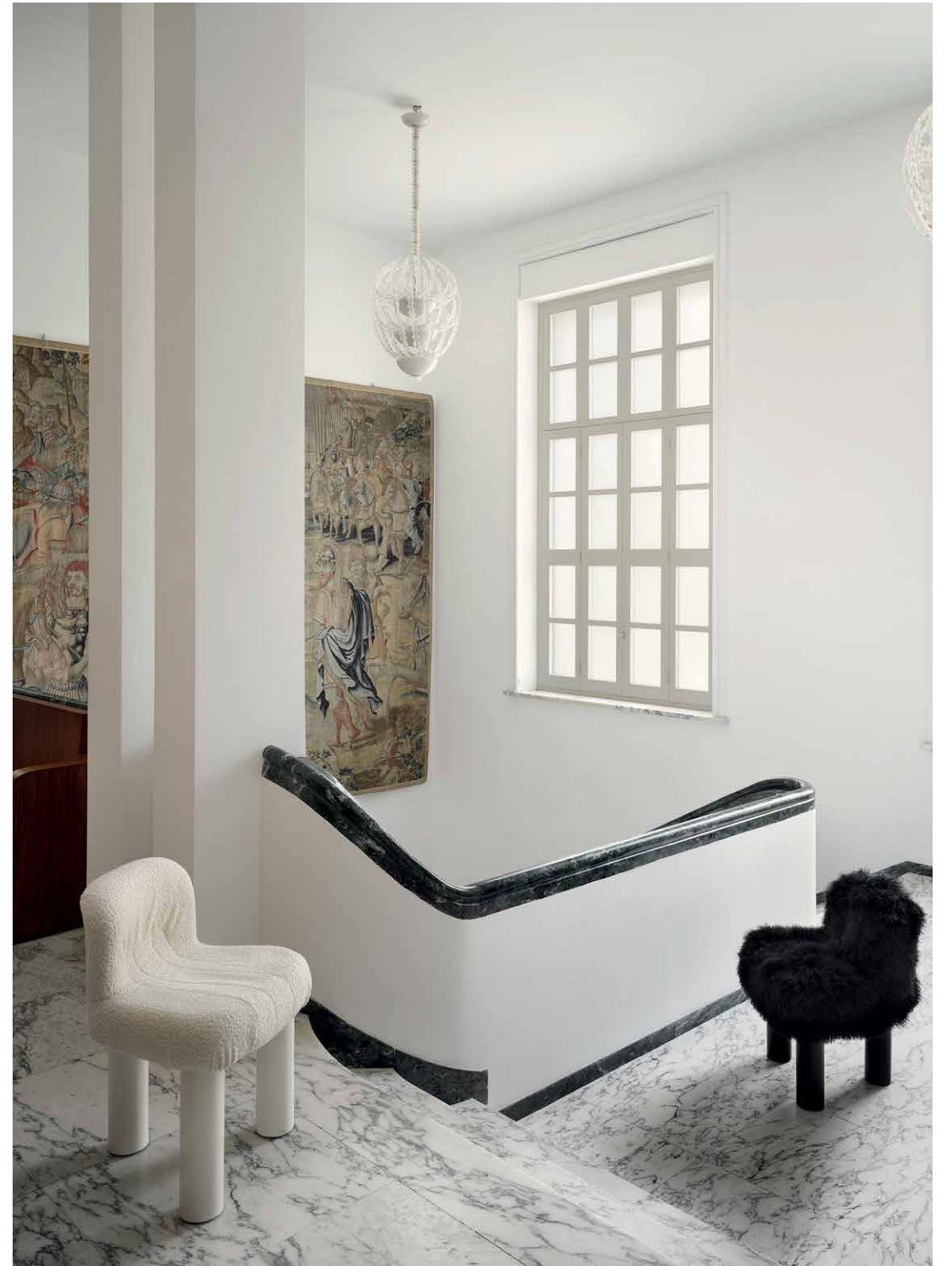
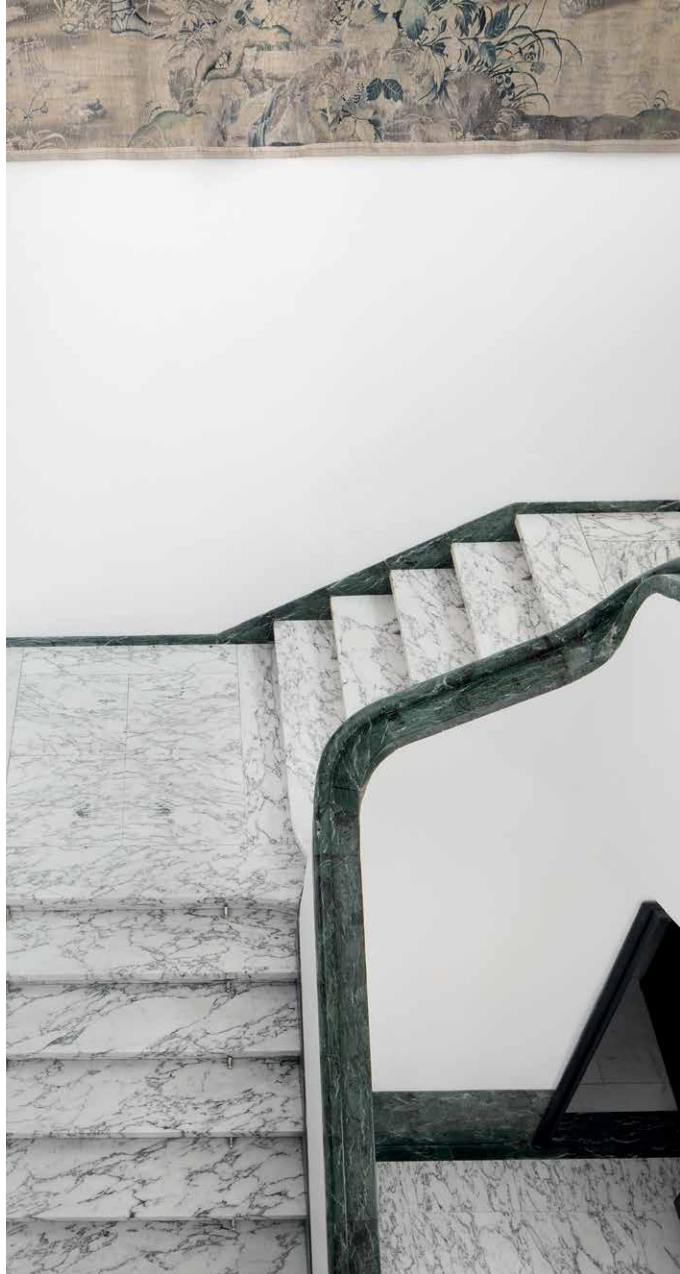





9000/sofa
composition NV 14
Delfino/armchair
Tablet/small table
Arcolor/small table
Match/bookcase

9000/sofa
composition NV 14
Delfino/armchair
Delfino/pouf
Tablet/small table



9000/sofa
composition NV 14
Delfino/armchair
Arcolor/small table

Cousy/sofa
Banah/dormeuse
Goya/small table





Cousy/sofa
Banah/dormeuse
Goya/small table



Delta Vienna/armchair



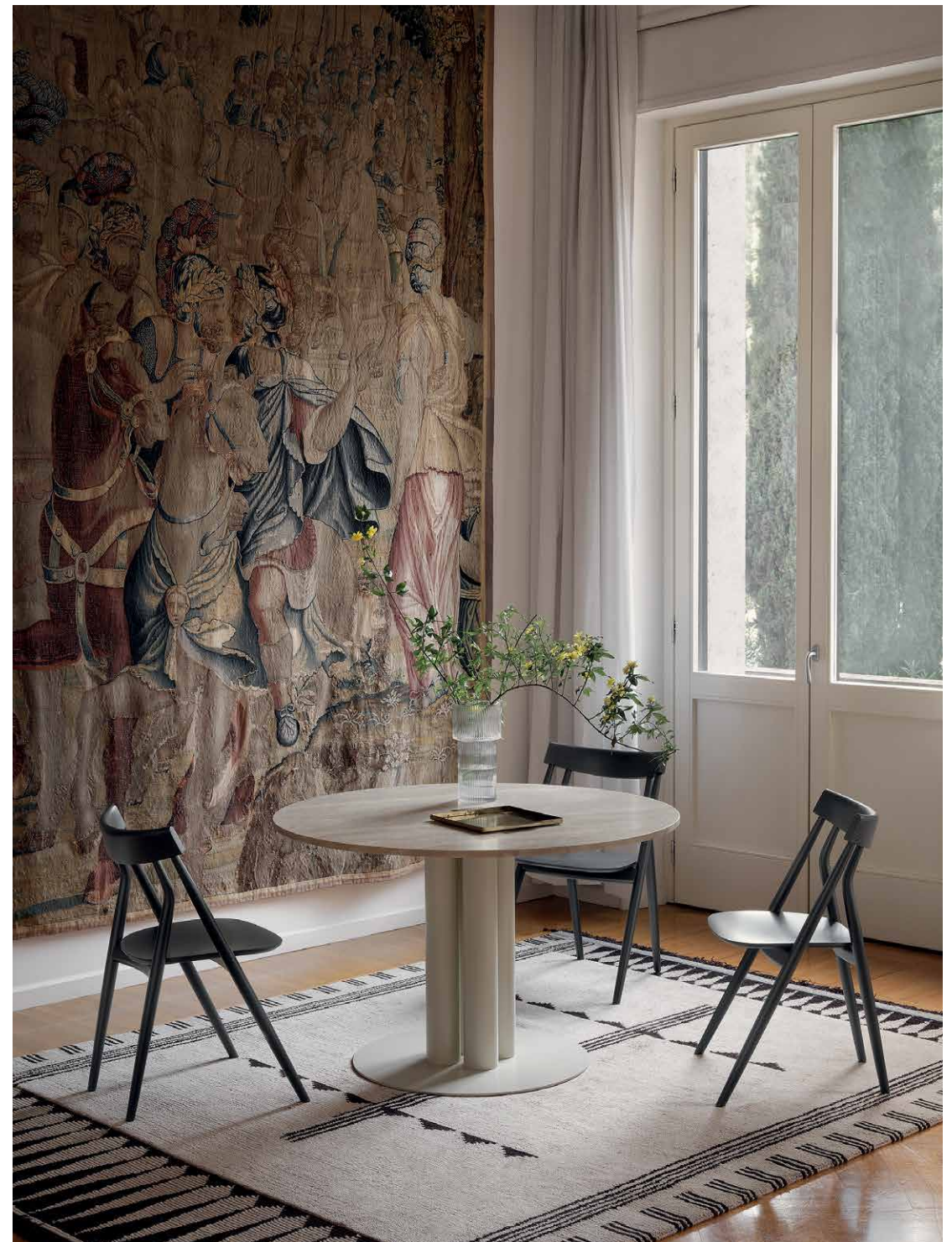

Goya/table
Lizzy/chair





Marengo/sofa
Marengo/armchair
Delta Vienna/armchair
Arcolor/small table
Tablet/small table



Marenco/sofa
Marenco/armchair
Delta Vienna/armchair
Arcolor/small table
Tablet/small table

Marengo

by Mario Marengo

Il design inconfondibile e l'ampia modularità fanno ancora del divano Marengo un must dell'arredamento contemporaneo. Disegnato da Mario Marengo nel 1970, rimane sempre un grande classico del design italiano. Con questo divano dai grandi cuscini arrotondati, Mario Marengo ha unito forza e comfort. Nel 2007 Marengo ha vinto il Wallpaper Design Awards Best Reissues.

The unmistakable design and wide modularity still make Marengo sofa a must-have in contemporary furniture. Designed by Mario Marengo in 1970, it always remains a great classic of the Italian design. With this large-rounded cushions sofa, Mario Marengo has combined strength and comfort. In 2007 Marengo won the Wallpaper Design Awards Best Reissues.

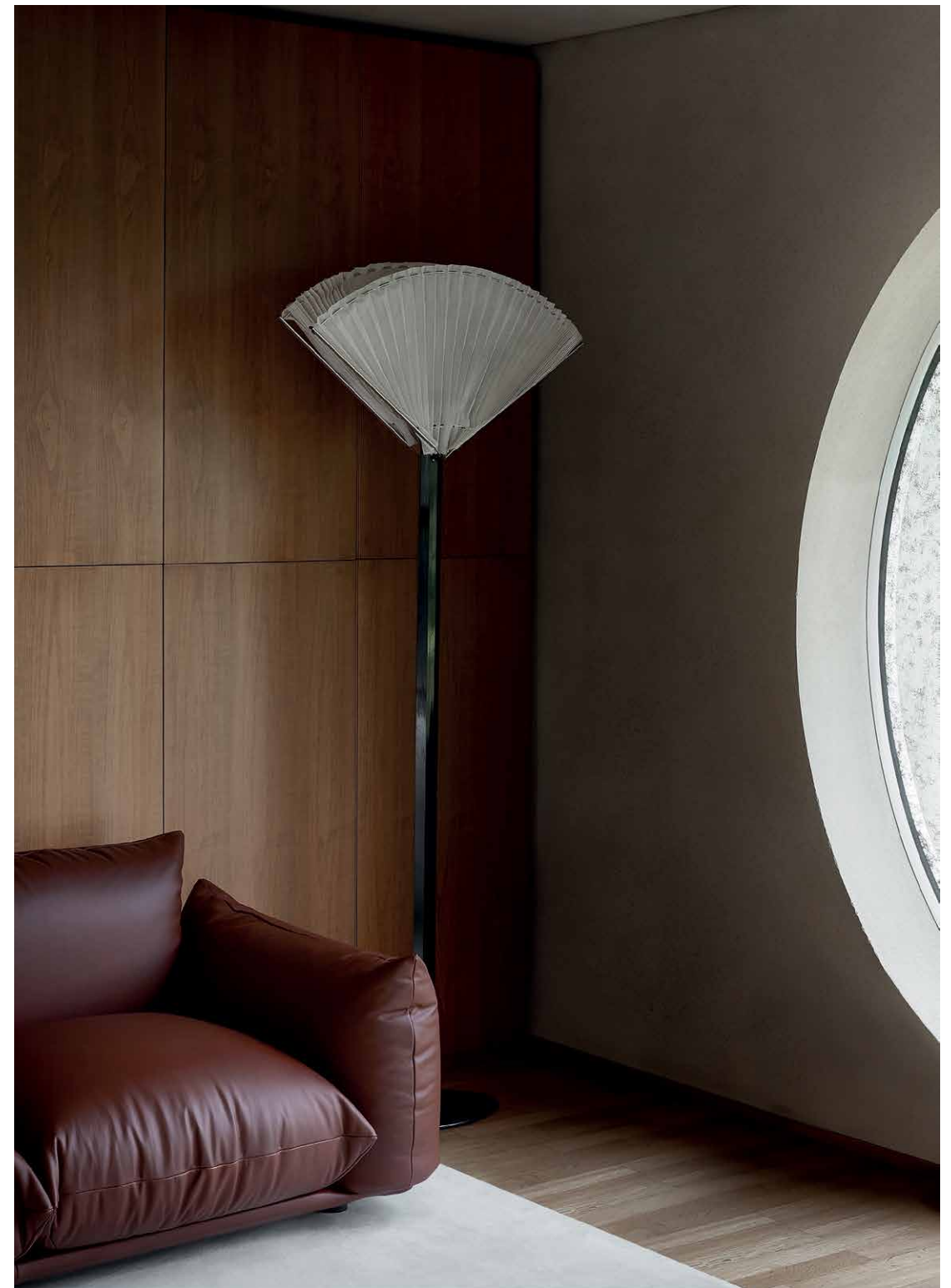
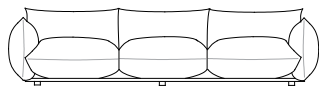





Marenco/sofa
Marenco/armchair
Tablet/small table
Arcolor/small table
Elettra/armchair
Goya/small table



Marenco/sofa
Tellin/armchair
Infinity/small table



Alba/bookcase
Marenco/armchair
Arcolor/small table



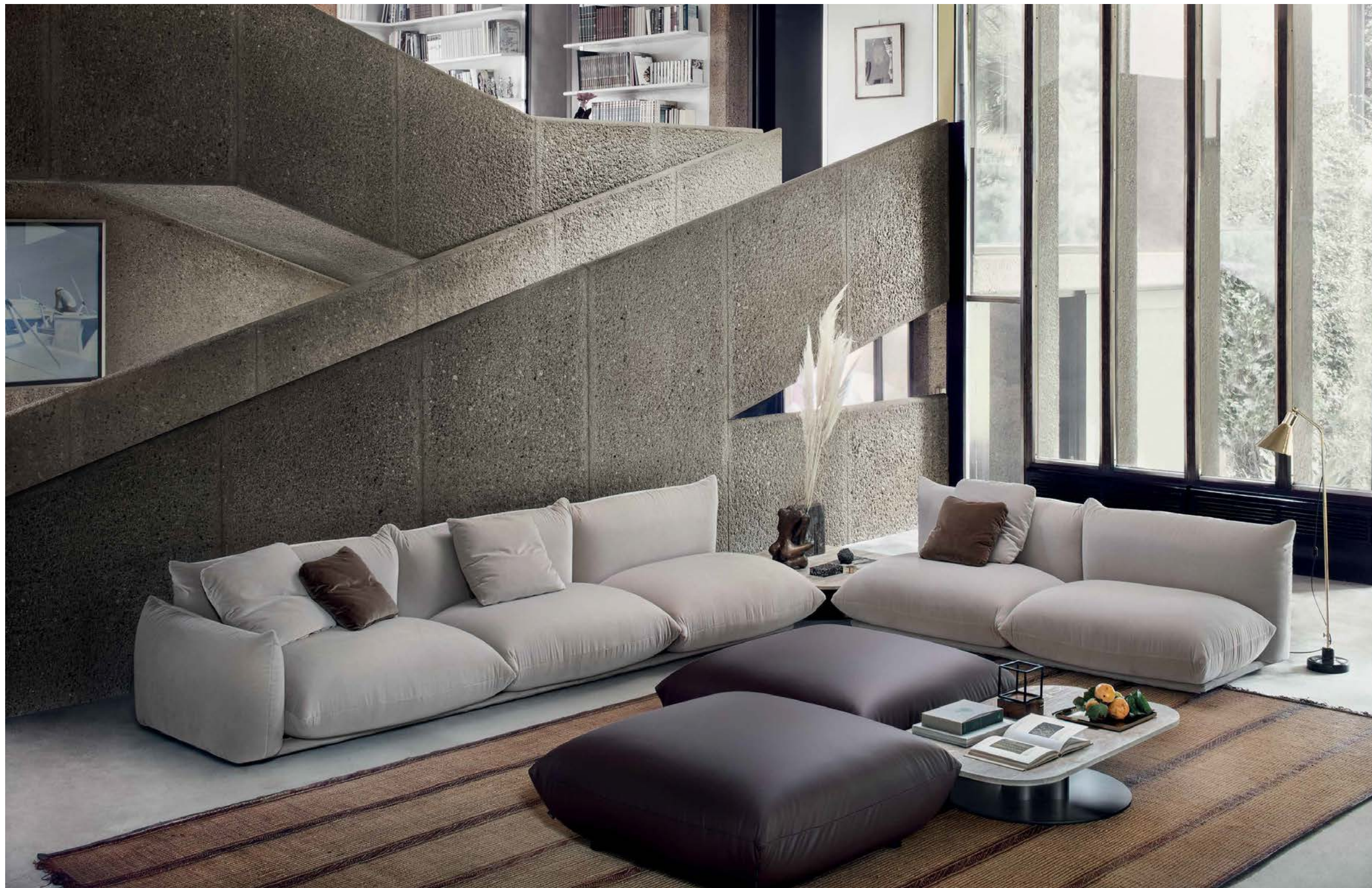

Marenco/sofa
Goya/small table
Virgola/armchair
capsule collection

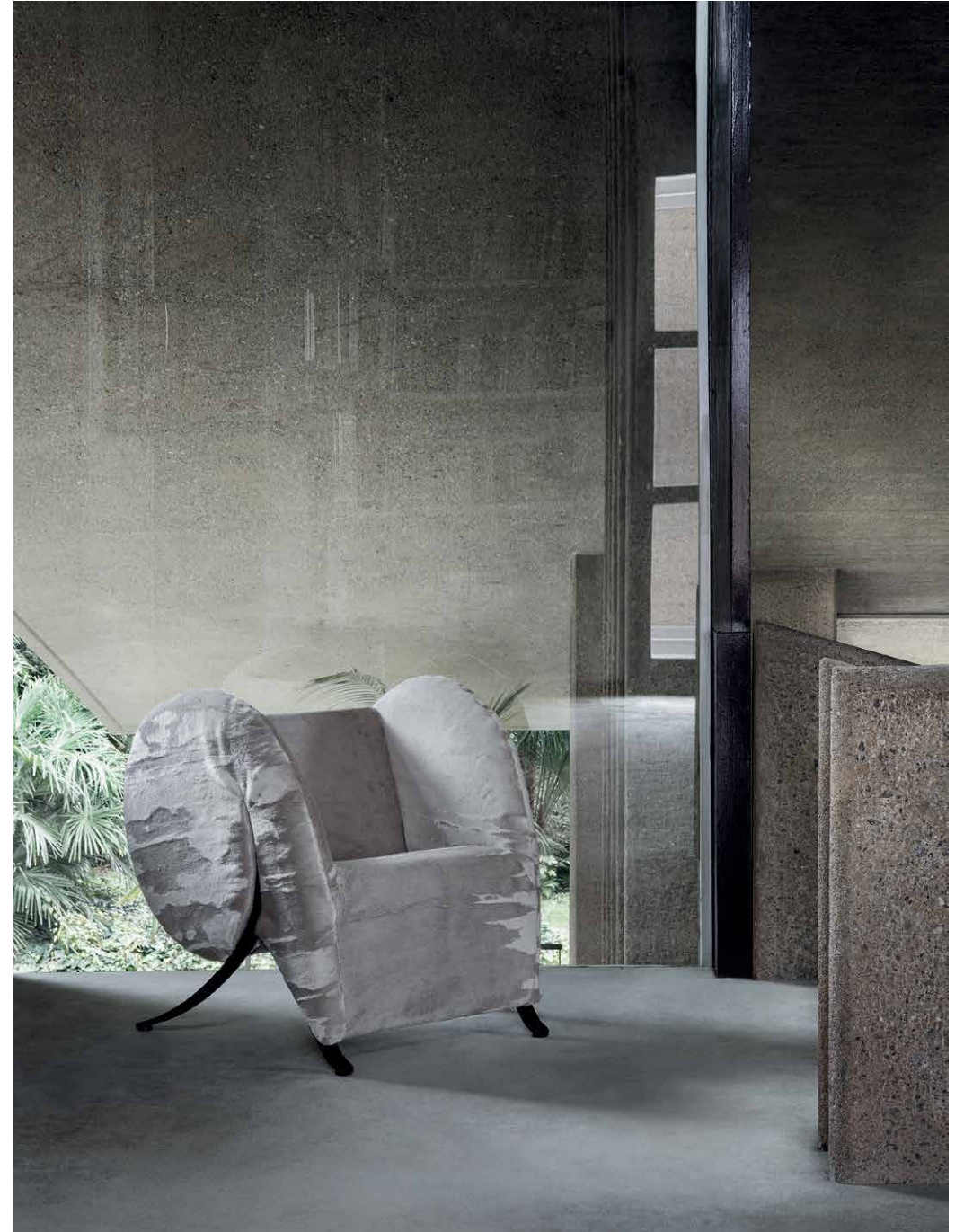

Virgola/armchair -
capsule collection

Elettra

by B.B.P.R.

Il primo grande progetto di B.B.P.R. risale al 1946, dopo la parentesi bellica e la pianificazione della ricostruzione per Milano. Accanto ai mobili per la casa, gli anni '50 vedono anche la realizzazione dei primi arredi per uffici e spazi pubblici, come il modello Elettra. B.B.P.R.'s first major design project dates back to 1946, after the war interlude and the reconstruction planning for Milan. Alongside furniture for home, the 1950s also saw the creation of the first furnishings for offices and public spaces, such as Elettra model.

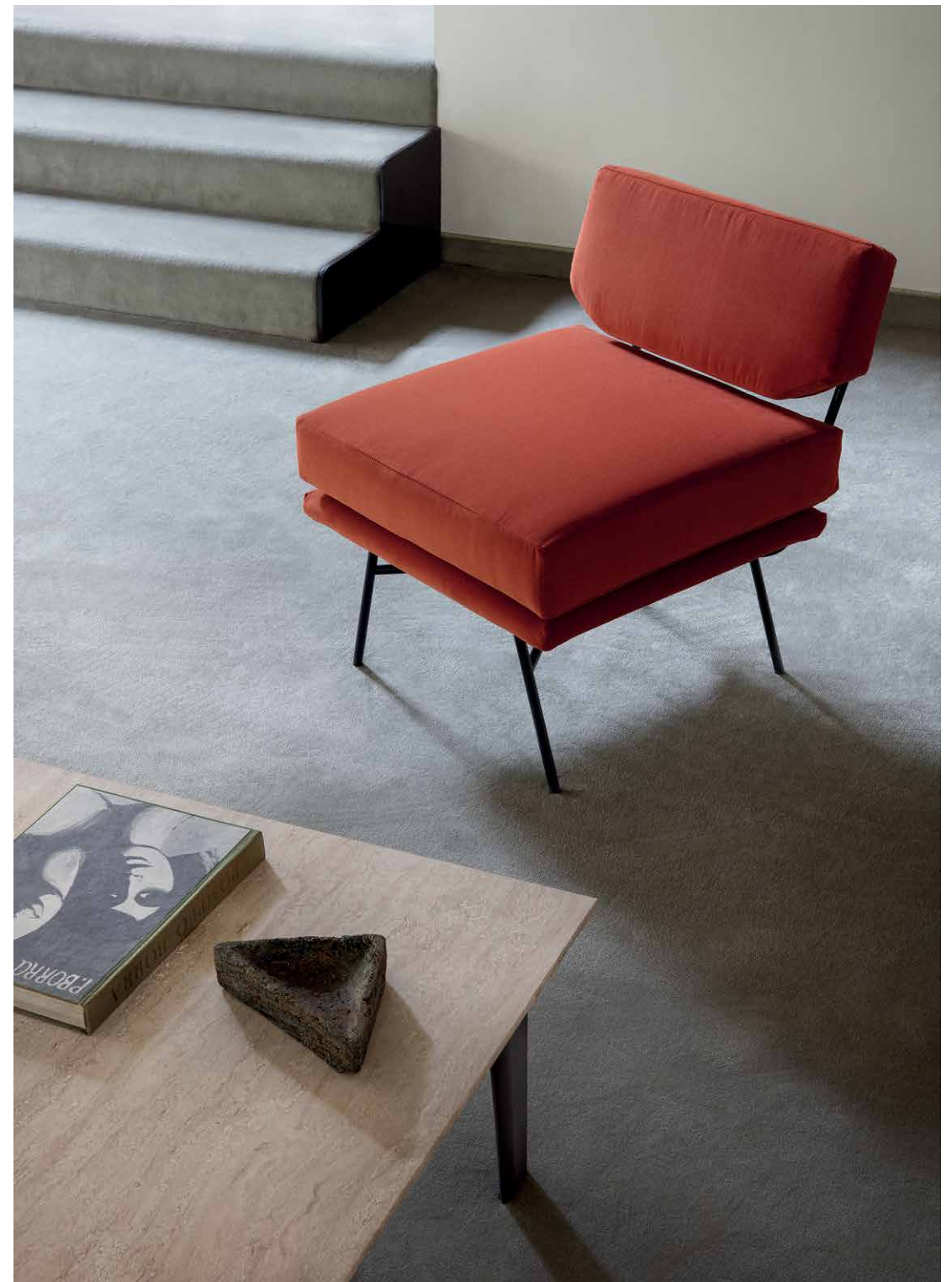

Elettra/armchair
Tablet/small table



Elettra/armchair
Infinity/small table



Delfino

by Erberto Carboni

La poltrona Delfino è un esempio significativo del settore del mobile cosiddetto “organico”, che si sviluppa negli anni Cinquanta e che spesso trae ispirazione dalle forme della natura, evitando ogni imitativo fraintendimento. Delfino armchair is a significant example of so-called “organic” furniture field, which develops in the Fifties and which often draws its inspiration by the nature shapes, avoiding any imitative misunderstanding.



64 / design collection



Delfino/armchair
capsule collection
Bloody 001
category T5
Tokio/sofa

65 / design collection

Papillon/wall lamp

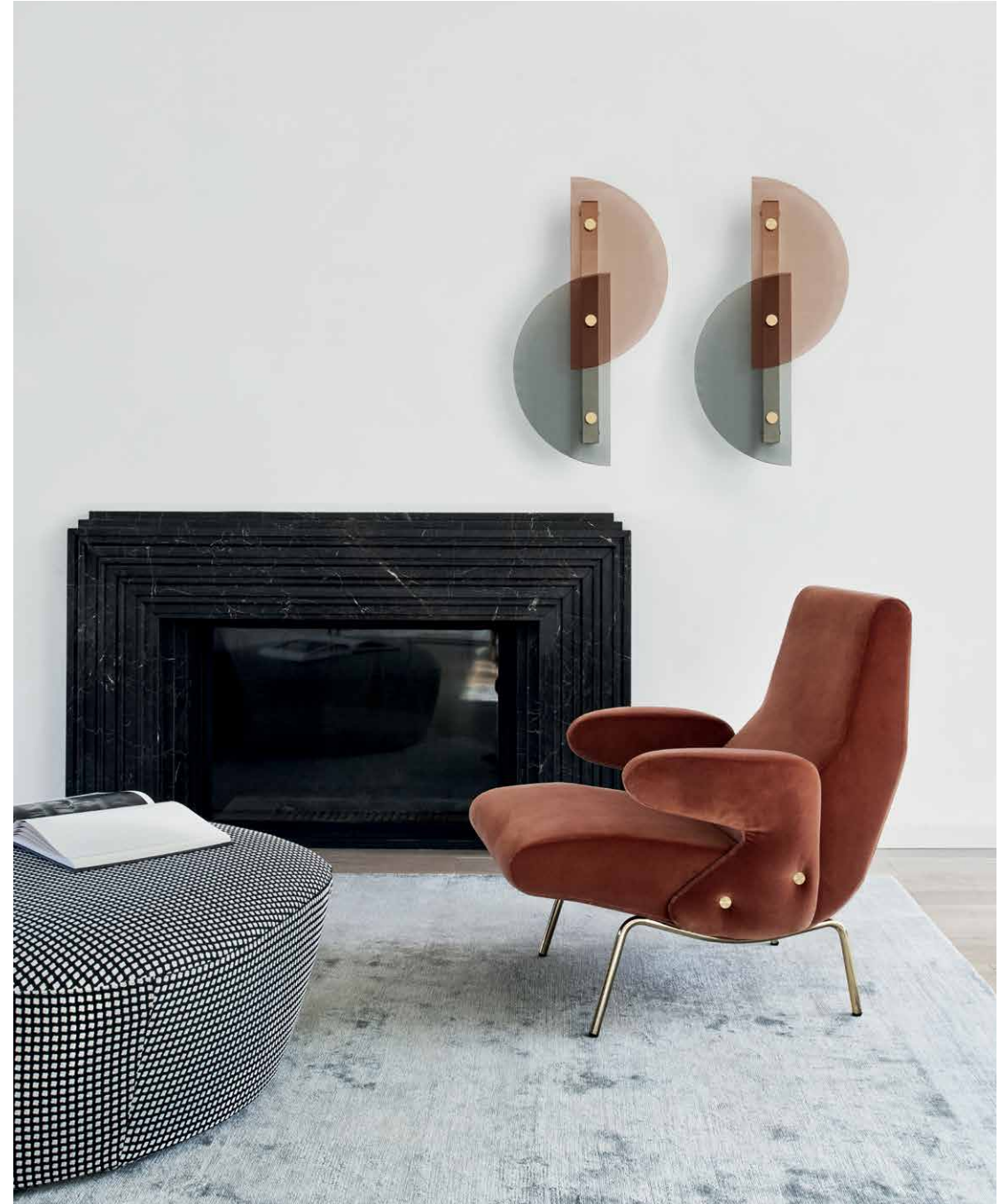
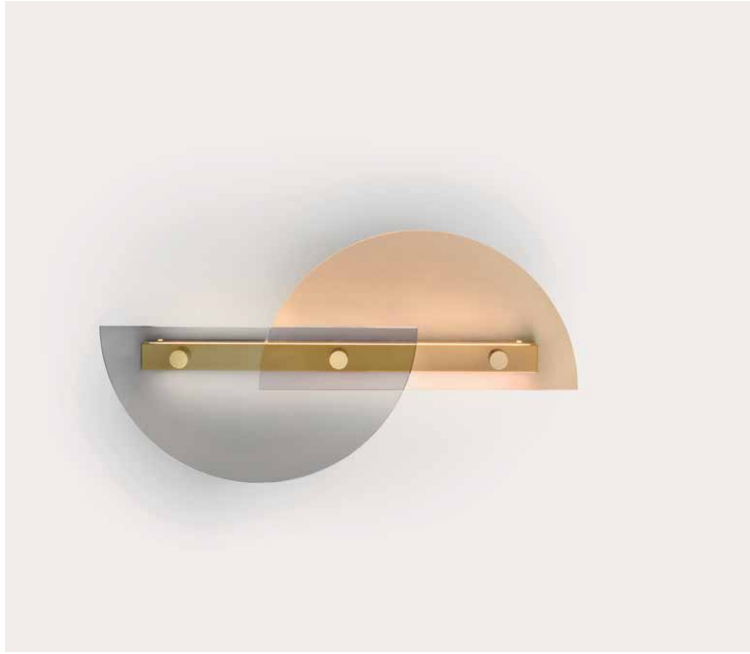

Delfino/armchair
Papillon/wall lamp
Penta/pouf

Marechiaro

by Mario Marengo

L'estrema essenzialità rende ancora oggi il divano Marechiaro, disegnato nel 1976 dall'architetto Mario Marengo, un prodotto fortemente contemporaneo, dall'aspetto informale e dal comfort rilassante. Un sistema di sedute componibile, che permette di creare composizioni dinamiche, dalle linee geometriche a quelle curve, adattandosi sia alla zona living che all'hospitality. The extreme essentiality still makes Marechiaro sofa, designed in 1976 by the architect Mario Marengo, a highly contemporary product, with an informal look and relaxing comfort. A modular seating system, that allows to create dynamic compositions, from geometric to curved lines, adapting to both living and hospitality areas.

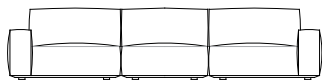

Marechiaro/sofa
composition MH II
Infinity/small table
Island/small table



Marechiaro/sofa
composition MH 08/B
Goya/small table

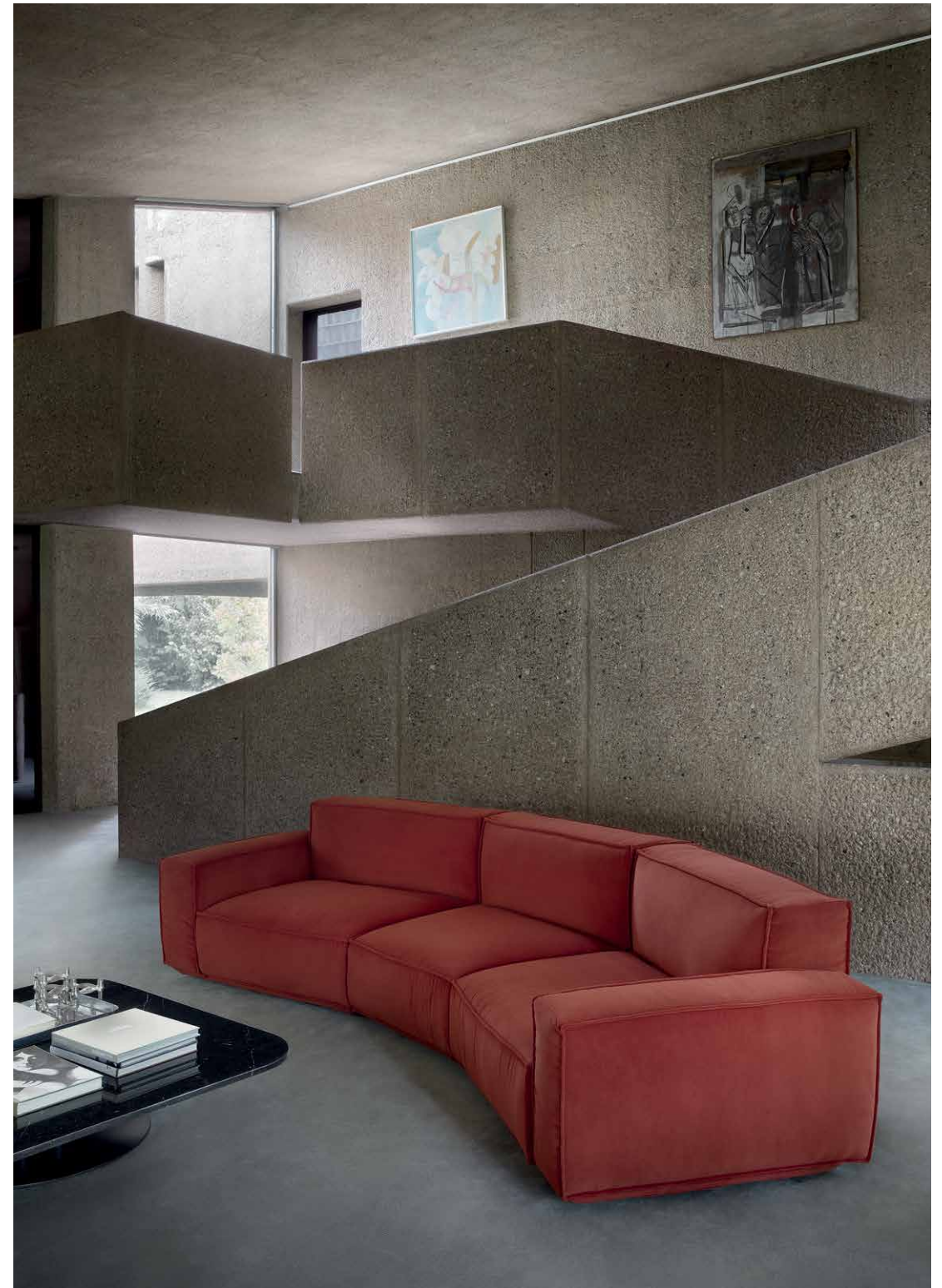

Marechiaro/sofa
composition MH 10



Marechiaro/sofa
composition MH 12

Marechiaro/sofa
composition MH 10
Match/small table
Cradle/armchair





Marechiaro/sofa
Cradle/armchair
Botolo/armchair
Bonsai/small table
Alba/bookcase

Fiorenza

by Franco Albini

In una pagina pubblicitaria Pirelli degli anni Cinquanta, la poltrona Fiorenza, disegnata da Franco Albini nel 1952, è stata utilizzata come immagine simbolo delle potenzialità della gommapiuma, che calza a pennello, e all'epoca, era il materiale tecnologicamente più avanzato utilizzato negli imbottiti. In a fifties' Pirelli advertising page, Fiorenza armchair, designed by Franco Albini in 1952, has been used as a symbol image of foam rubber's potential, which fits like a glove and at that time, was the most technologically advanced material used in upholstered furniture.

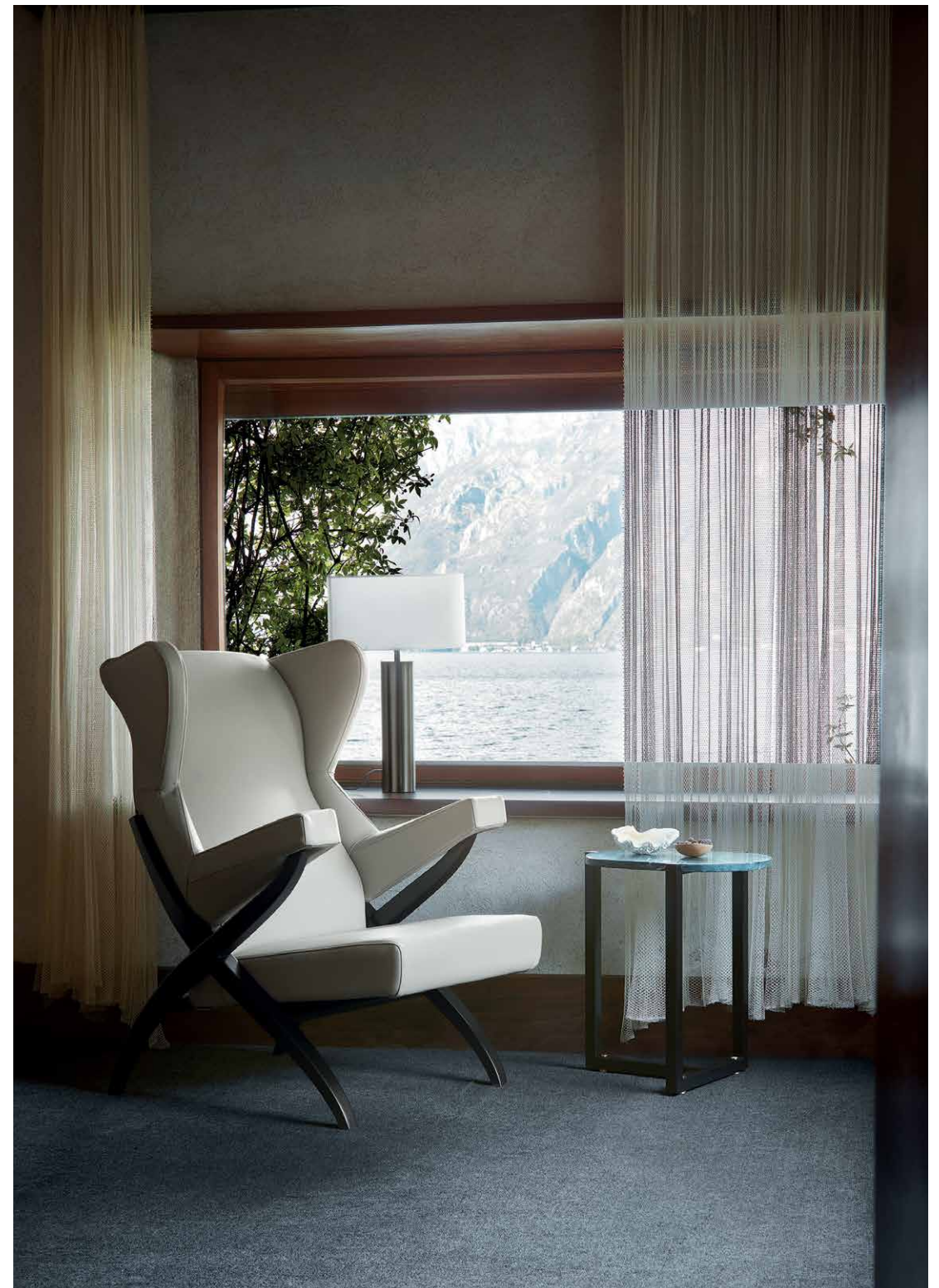

Fiorenza/armchair
Sigmund/small table

Fiorenza/armchair
Goya/small table

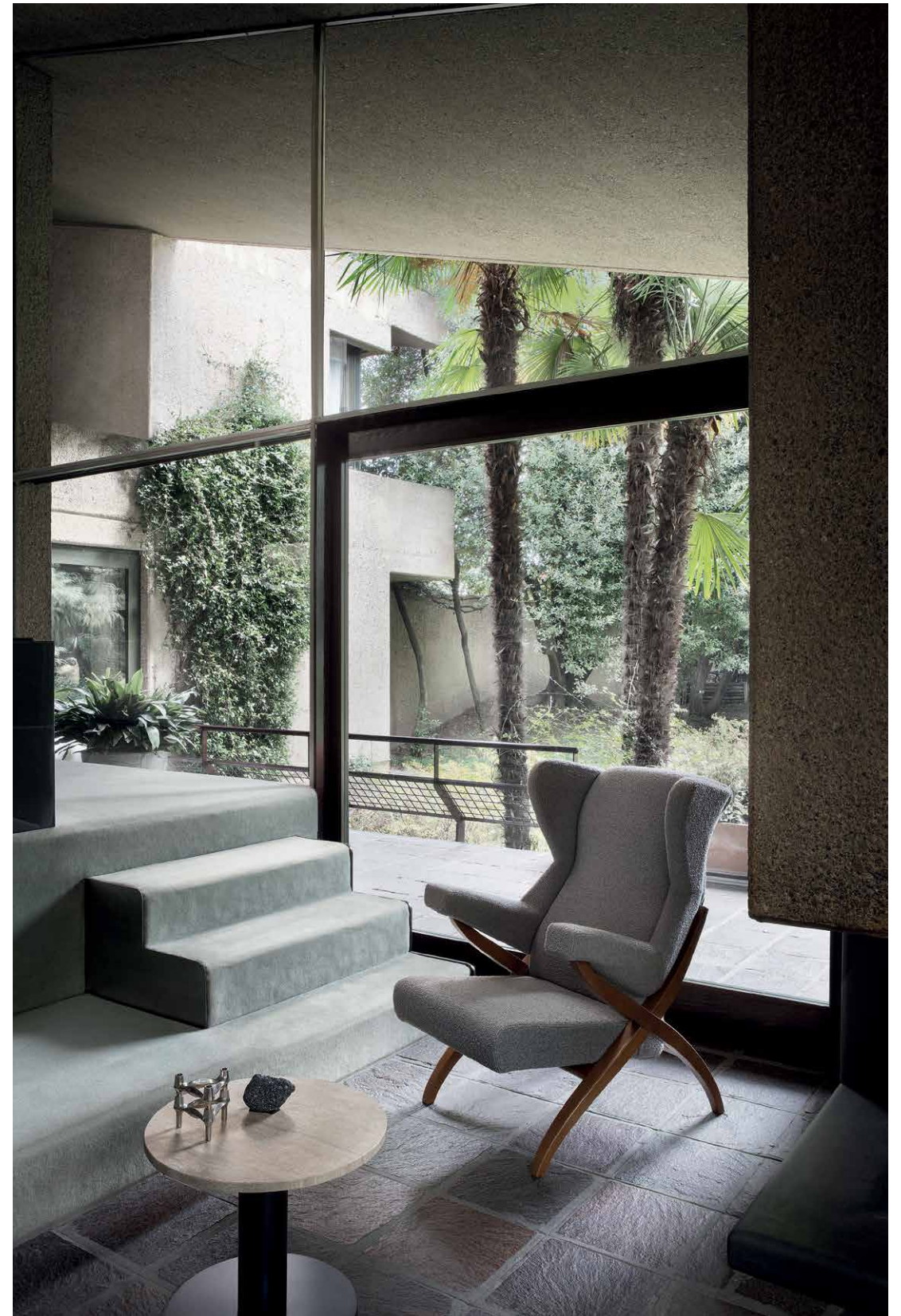

Strips

by Cini Boeri

All'inizio degli anni Settanta, l'architetto Cini Boeri ha rivoluzionato il mercato del mobile con il suo modello, che resta oggi un "evergreen": il divano componibile Strips, che appartiene alla storia di arflex. Sicuramente è uno dei prodotti più famosi, disegnato nel 1968, premiato con il Compasso d'Oro ed è esposto in diversi musei del mondo, come la Triennale di Milano, a Tokyo, il Moma di New York. At the beginning of the Seventies, the architect Cini Boeri revolutionized the furniture market with her model, that stays nowadays an "evergreen": the modular sofa Strips, which belongs to arflex history. Surely it is one of the most famous products, designed in 1968, which awarded the prize Compasso d'Oro and it is displayed in several museums all over the world, such as Triennale in Milan, in Tokyo, Moma in New York.



80 / design collection



Strips/sofa
composition S 3
Hall/armchair
capsule collection
Riga 01 category T6
Sigmund/small table

81 / design collection



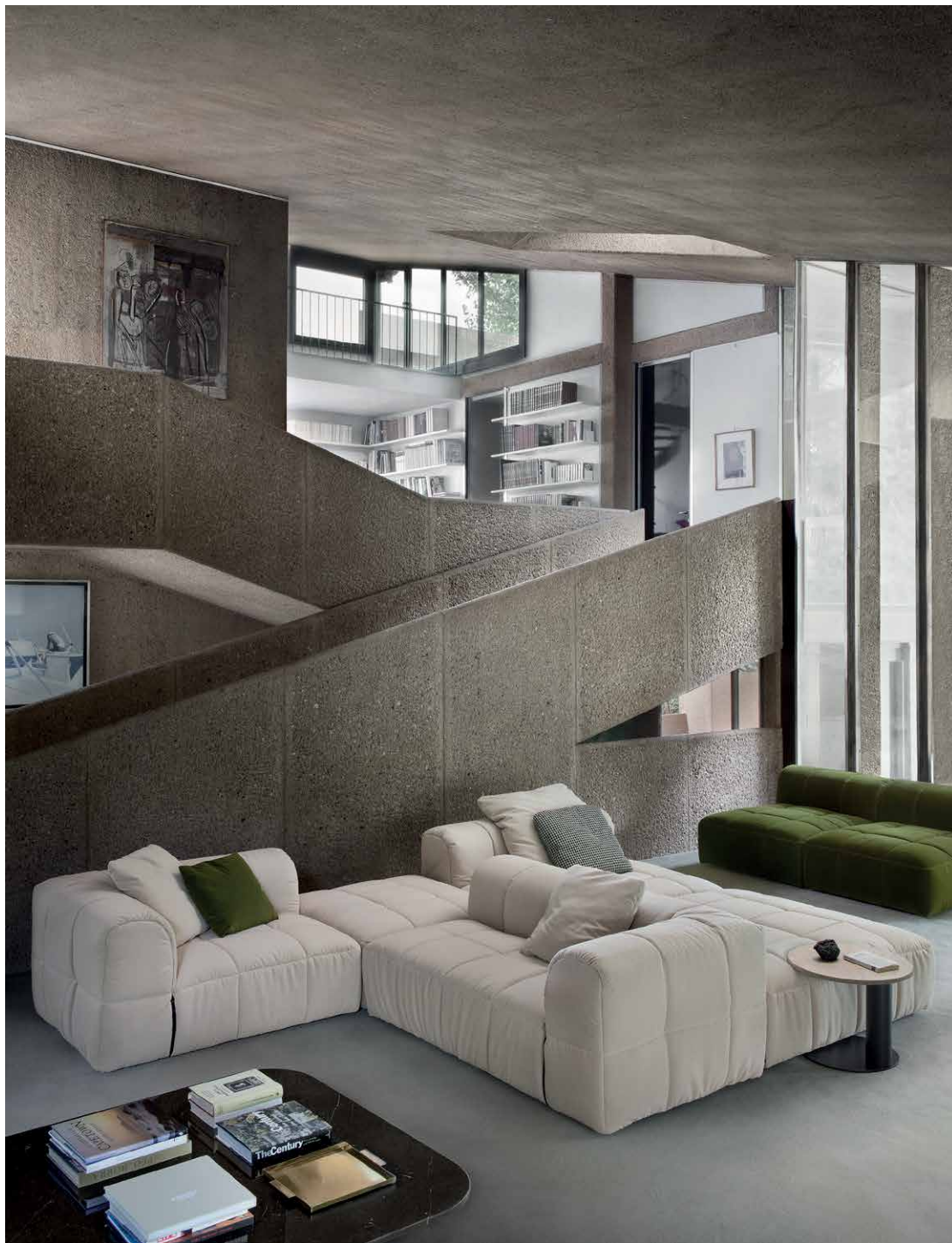

Strips/sofa
composition S 20
Goya/service table
Goya/small table

Strips/sofa
composition S 18



Strips/sofa
composition S 19



Strips/sofa
composition S 20



Suppli

by Luca Nichetto

Suppli è una poltrona invitante ed elegante. Le curve morbide e sinuose emanano calore e incarnano un'ancora spaziale quasi perfetta per il riposo e il relax. Suppli is an inviting and elegant armchair. Soft and sinuous curves exude warmth and embody a near perfect spatial anchor for rest and relaxation.

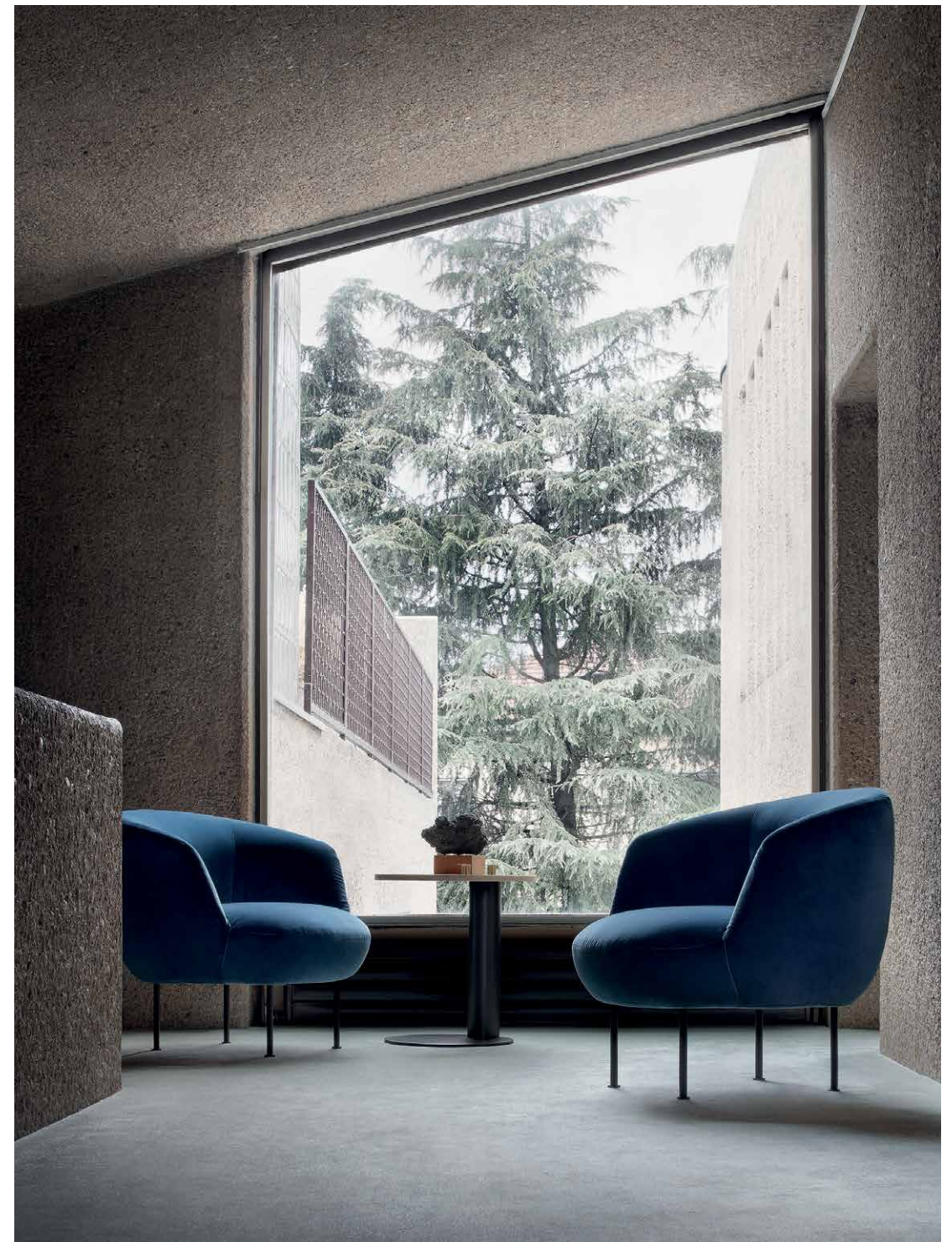

Suppli/armchair
Sigmund/small table

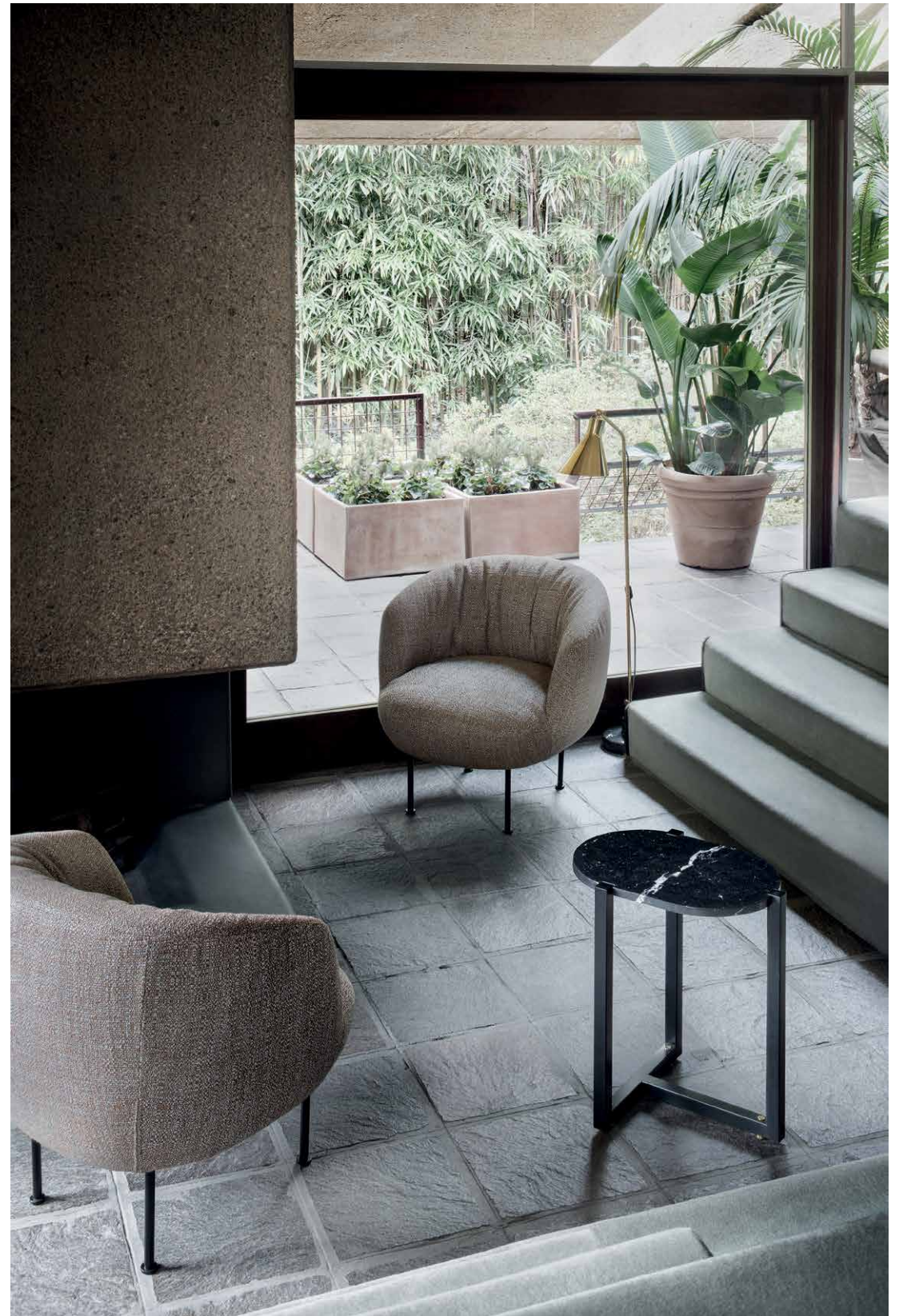
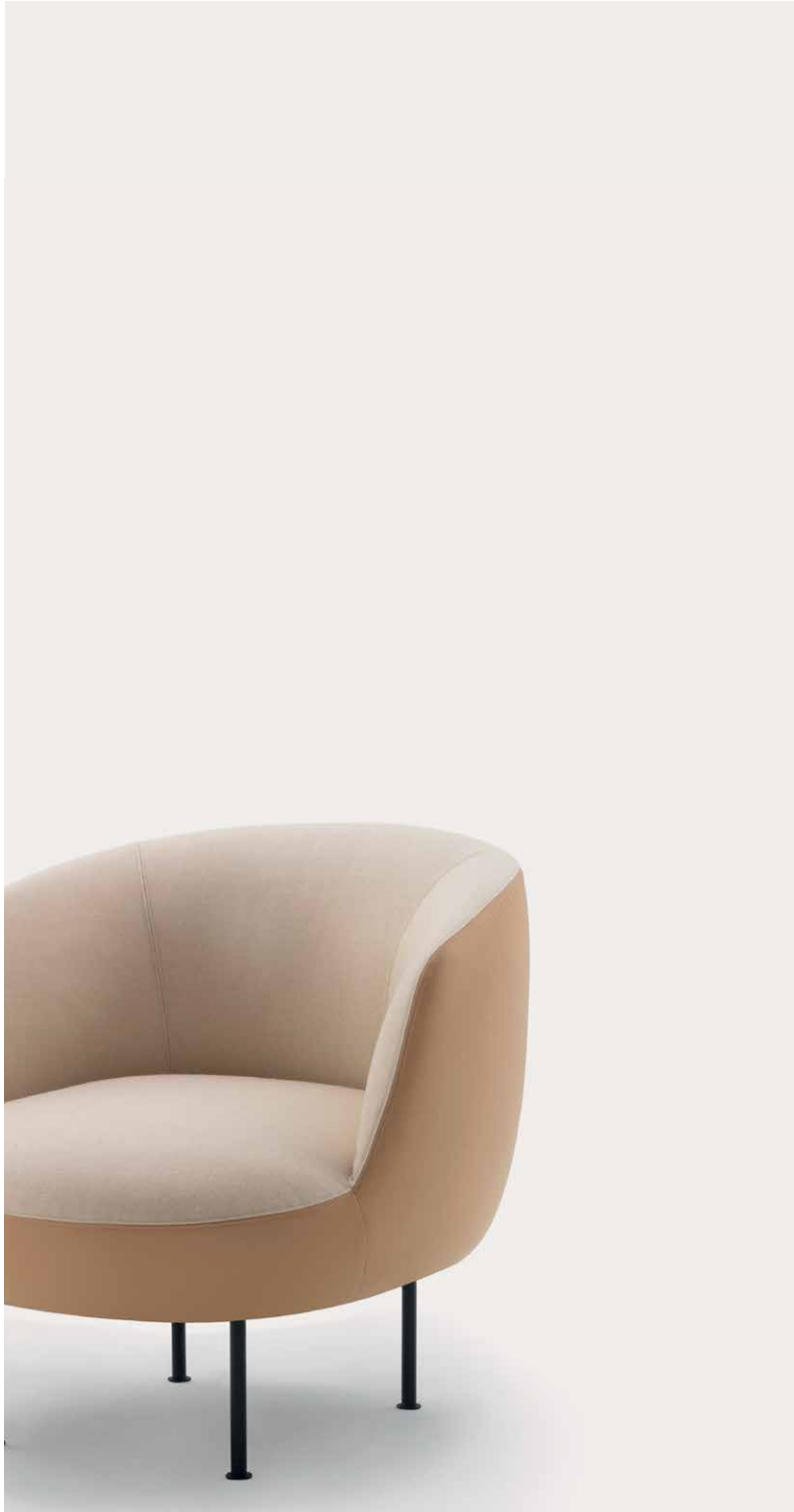

Banah

by Luca Nichetto

Banah nasce con l'intento di creare un design audace, che respira riferimenti a tutte le icone dell'azienda. I suoi tratti più riconoscibili si incontrano e trovano un equilibrio attraverso un approccio organico orientato ad allontanarsi dagli archetipi. Evitando qualsiasi simmetria, il divano acquisisce una forma irregolare, come se nascesse da un disegno spontaneo. Banah was born with the intent to create a bold design, that breathes references to all the icons of the company. Its most recognisable features meet and find a balance through an organic approach oriented to move away from archetypes. Avoiding any symmetries, the sofa acquires an irregular shape, as if born from a spontaneous drawing.

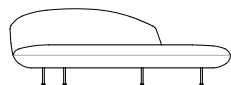

90 / design collection

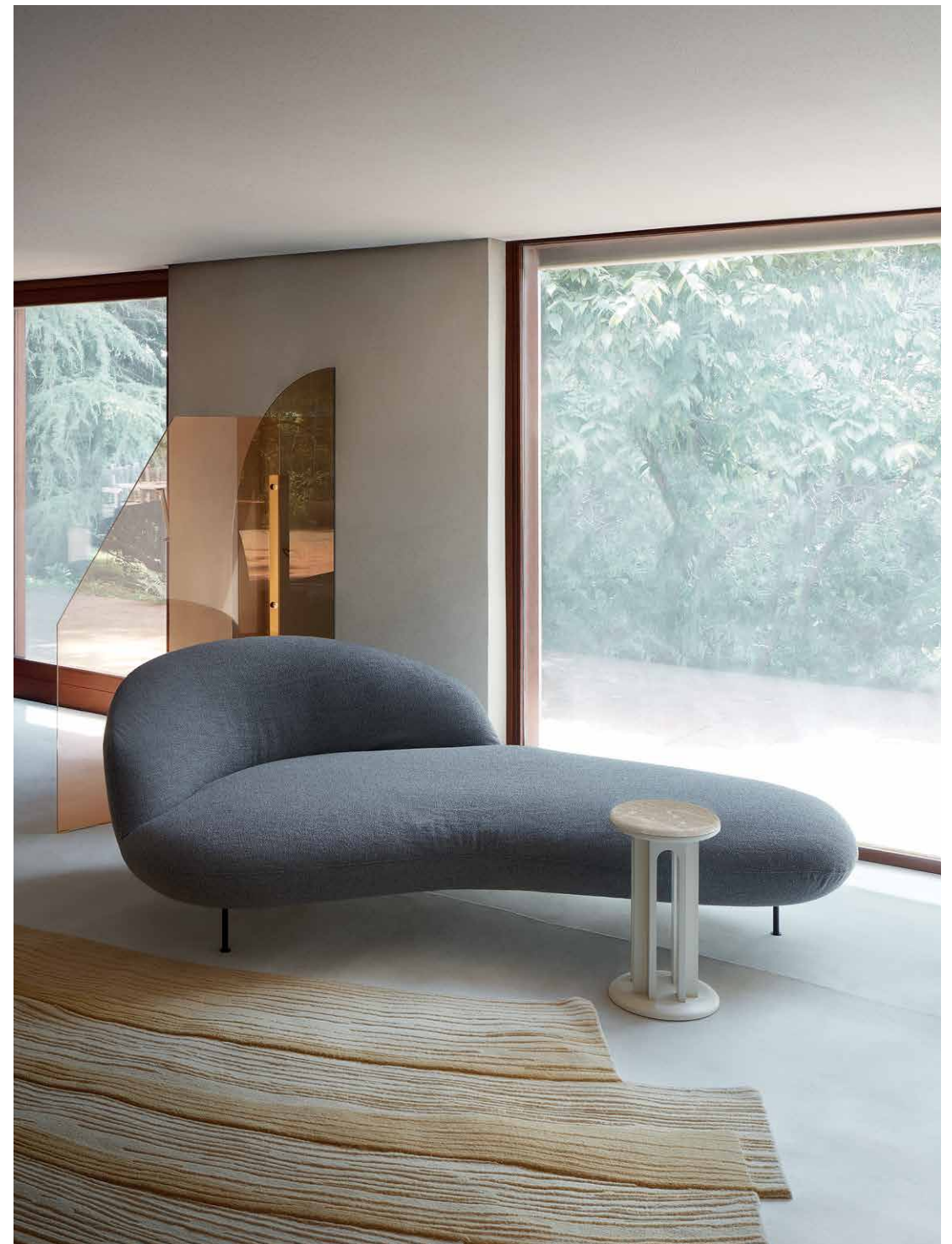

Banah/dormeuse
Arcolor/small table
Vela/screen

91 / design collection



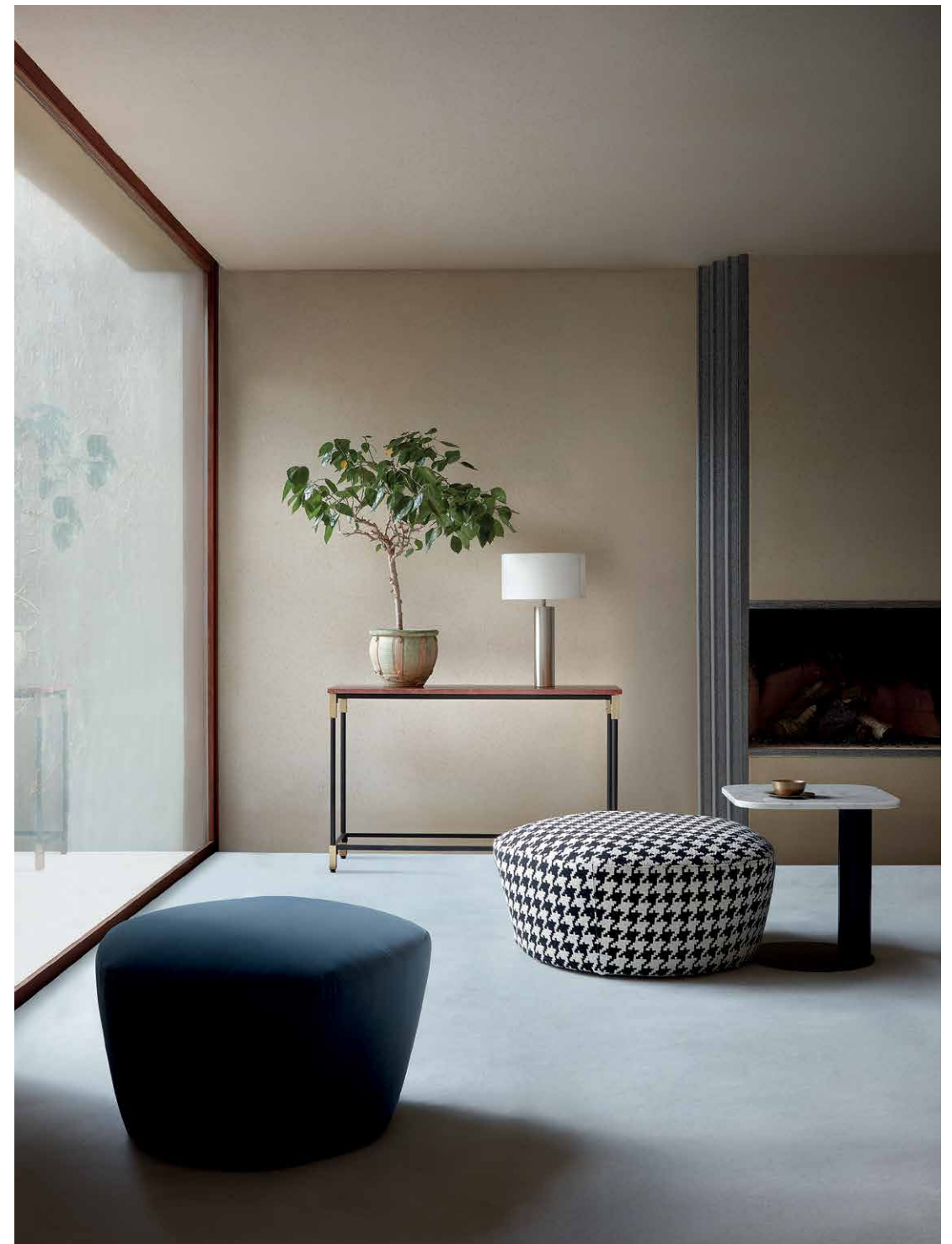

Bel Air

by Claesson Koivisto Rune

Sistema di sedute dall'eleganza semplice e sobria, proporzionato per raggiungere un'orizzontalità ariosa, che comunica un 'modernismo ottimista' tipicamente italiano. C'è anche un attento rivestimento dei dettagli attorno alle superfici esterne di ogni elemento. Seating system with simple and sober elegance, proportioned to achieve an airy horizontality, that communicates a quintessentially Italian 'Optimistic Modernism'. There is also a careful upholstery detailing around the outer surfaces of each element.

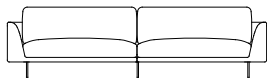
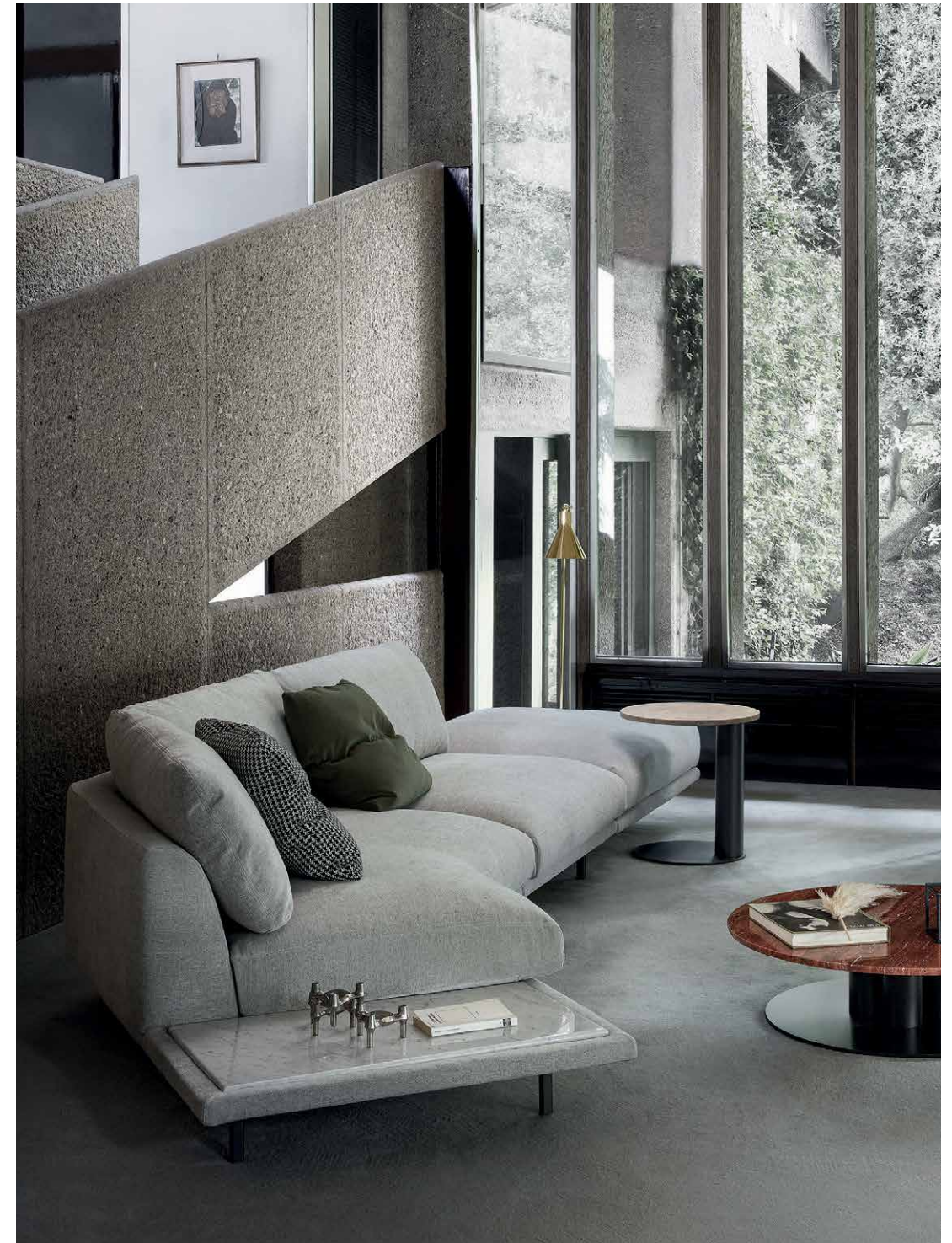



Bel Air/sofa
composition AB 08
Goya/small table
Goya/service

Bel Air/sofa
composition AB II



Bel Air/sofa
composition AB 04
Match/small table
Arcolor/small table

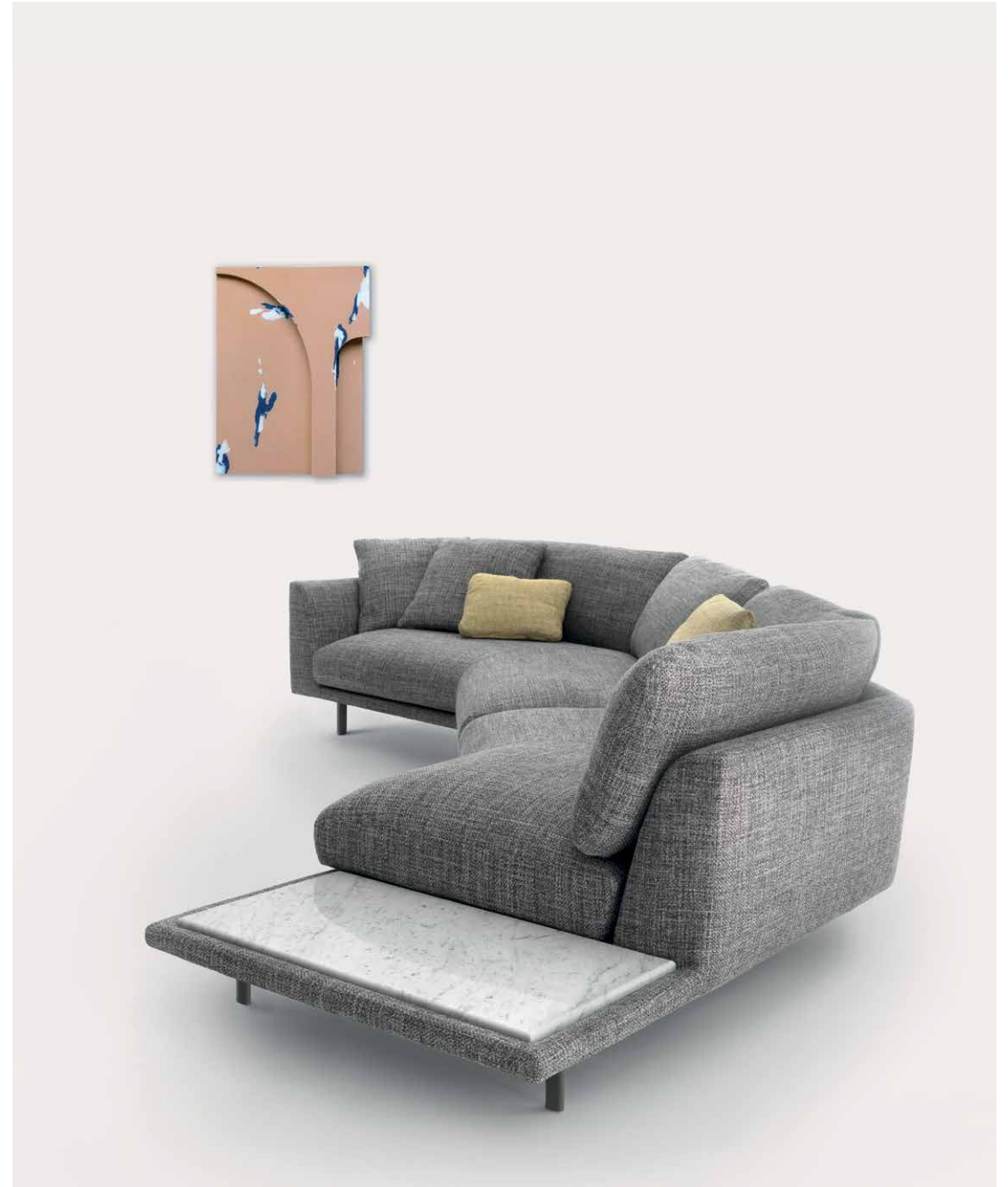

Goya

by arflex

Goya è una famiglia di tavoli, tavolini e service, dalle linee rotonde, essenziali e semplici, di grande impatto visivo, che permette di adattarsi a qualsiasi ambiente, completandolo con eleganza. Goya is a family of tables, small tables and services, with round, essential and simple lines, with a great visual impact, that allows to adapt itself to any environment, completing it with elegance.



102/designcollection

Goya/table
Neptunia/chair

103/designcollection



Goya/small table
Goya/service



Goya/small table
Lee/sofa
9000/armchair

Cradle

by Neri&Hu

La poltrona e il divano attingono sia dalla ricca stirpe del mobile italiano, noto per le sue forme scultoree e audaci, sia dalla sensibilità modernista, che richiede un'onesta espressione strutturale. Piuttosto che nascondere il telaio e tentare di sollevare i modelli da terra, gli eleganti elementi di supporto realizzati a mano diventano essi stessi il punto forte del prodotto. The armchair and the sofa draw both from the rich lineage of Italian furniture, known for its sculptural and bold shapes, as well as from the modernist sensibility, that demands an honest structural expression. Rather than conceal the frame and attempt to make the models lift from the ground, the elegant crafted supporting elements become themselves the highlight of the product.



106/designcollection

Cradle/armchair
Capilano/small table

107/designcollection

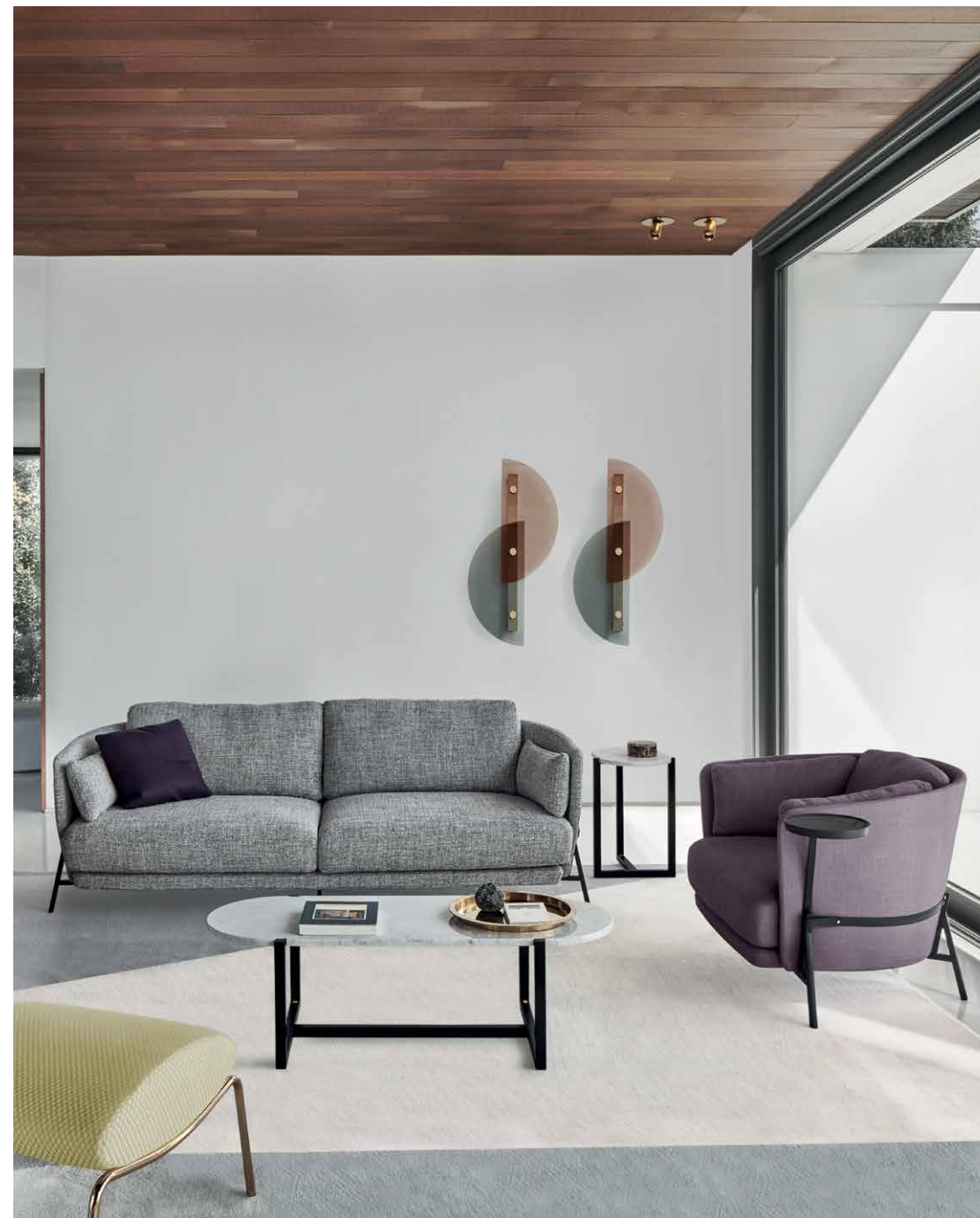

Cradle/sofa
Cradle/armchair
Cradle/service
Sigmund/small table
Delfino/pouf
Papillon/wall lamp

Deep Cradle/sofa

Goya/small table



9000

by Tito Agnoli

Alla fine degli anni '60, i designer iniziano a realizzare mobili mini e versatili, pensati per spazi domestici compatti e multitasking. arflex, da sempre impegnata in un costante lavoro di ricerca e realizzazione, presenta 9000, di Tito Agnoli, una serie di sedute contenute e variamente articolate. Le ridotte dimensioni e la facile componibilità rappresentano una valida soluzione a diverse problematiche di arredo, sia per ambienti domestici che collettivi. At the end of the 60's, the designers started realizing mini and versatile furniture, conceived for small and multitasking domestic spaces. arflex, always engaged in a constant work of research and realizations, presents 9000, by Tito Agnoli, a series of compact and variously articulated seats. The contained dimensions and the easy modularity represent a valid solution to different furnishing problems, both for home and collective environments.

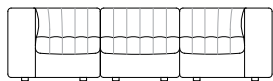

112/designcollection

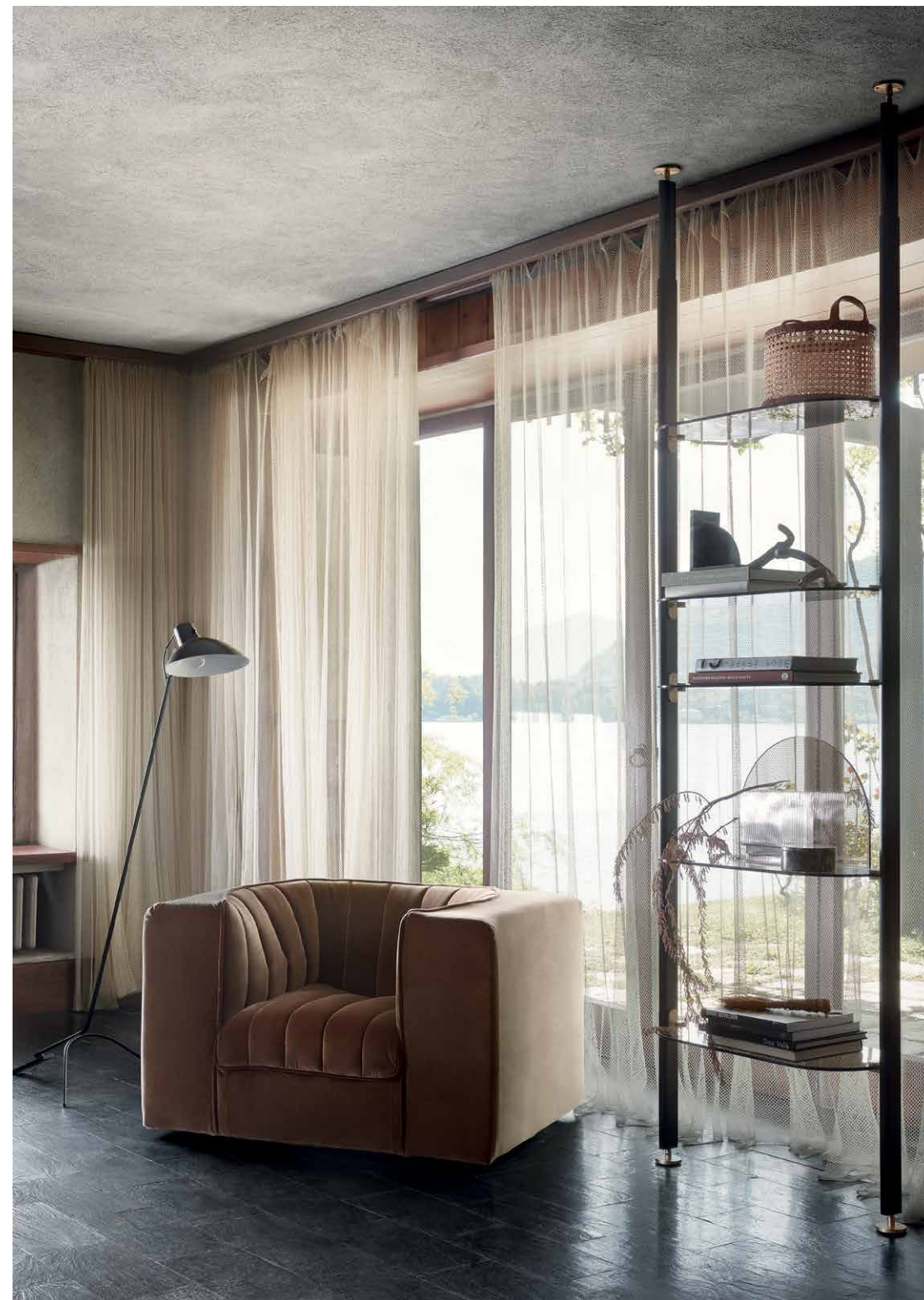

9000/armchair
Alba/bookcase

113/designcollection



9000/sofa
composition NV 11
9000/armchair
Sigmund/small table
Goya/service



9000/sofa
9000/pouf
Bonsai/small table
Arcolor/small table
Suppli/armchair

9000/sofa
composition
NV 04

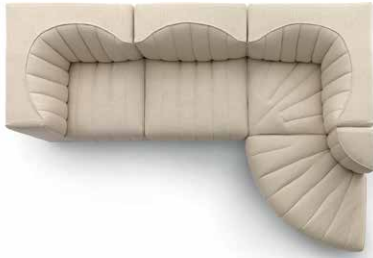

9000/sofa
composition
NV 06



9000/sofa
composition
NV 09



9000/sofa
composition
NV 08



9000/sofa
composition
NV 13



9000/sofa
composition
NV 12



9000/sofa
composition
NV 11



9000/sofa
composition
NV 10

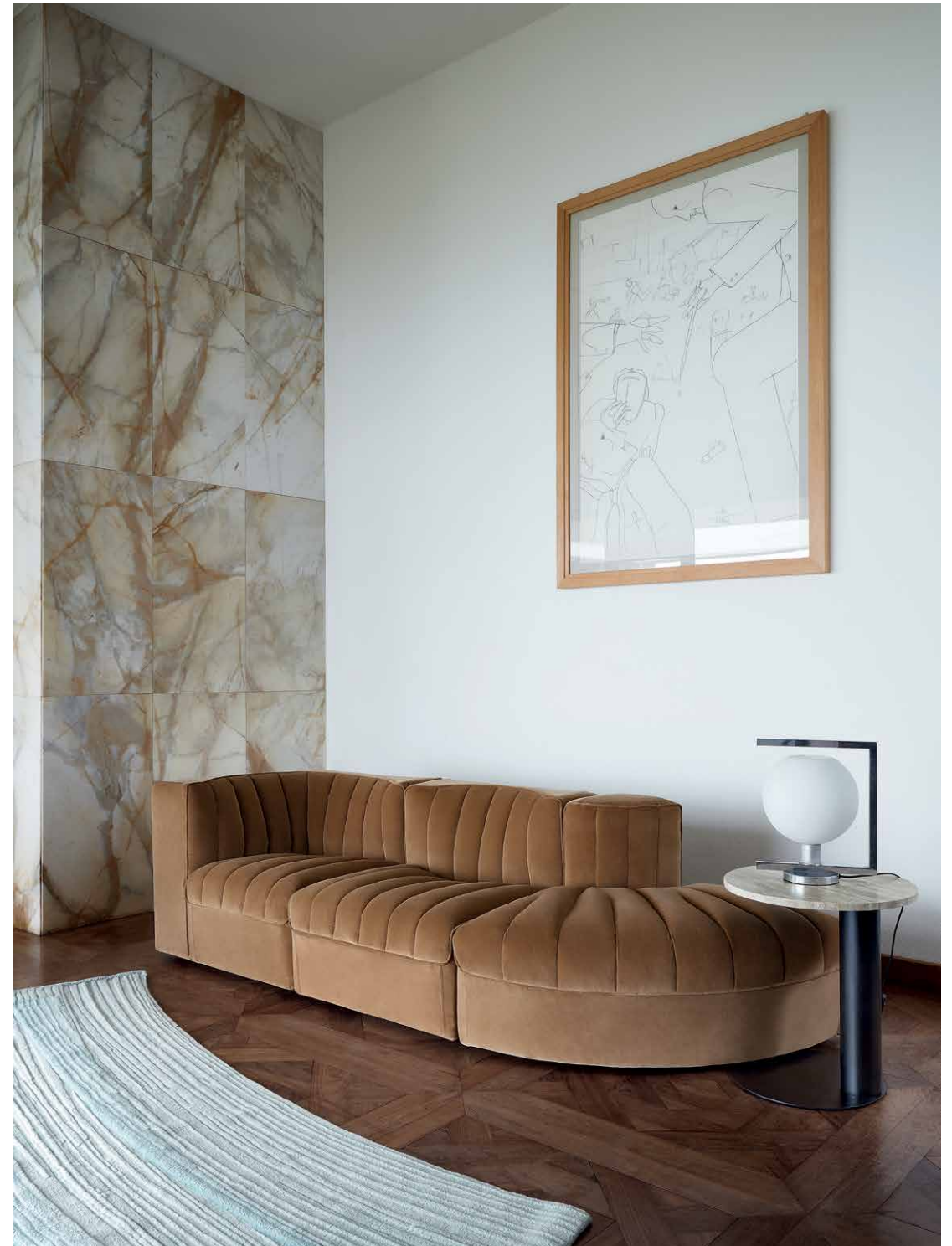

9000/sofa
composition NV 07-B
Goya/service

Threshold

by Neri&Hu

La parola cinese “jian” può essere tradotta in “spazio” o “intervallo”, ma è anche la parola unitaria per una “stanza”. In senso architettonico, questo termine può essere inteso come una condizione di soglia - la mediazione fisica tra due ambienti spaziali contrastanti, come l’interiorità e l’esteriorità, o pubblico e privato - ma implica anche che la soglia non sia un meccanismo passivo, avendo il potenziale per alterare attivamente configurazioni e relazioni spaziali. The Chinese word “jian” can be translated into “gap” or “interval”, but it is also the unit word for a “room”. In an architectural sense, this term can be understood as a threshold condition—the physical mediation between two contrasting spatial environments, such as interiority and exteriority, or public and private—but it also implies that the threshold is not a passive mechanism, having the potential to actively alter spatial configurations and relationships.

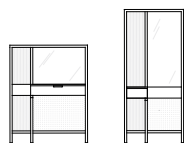

120 / designcollection



Threshold/low mirror cabinet
Botolo/armchair

121 / designcollection



Threshold/low mirror cabinet

122/*designcollection*

Threshold/high mirror cabinet



123/*designcollection*

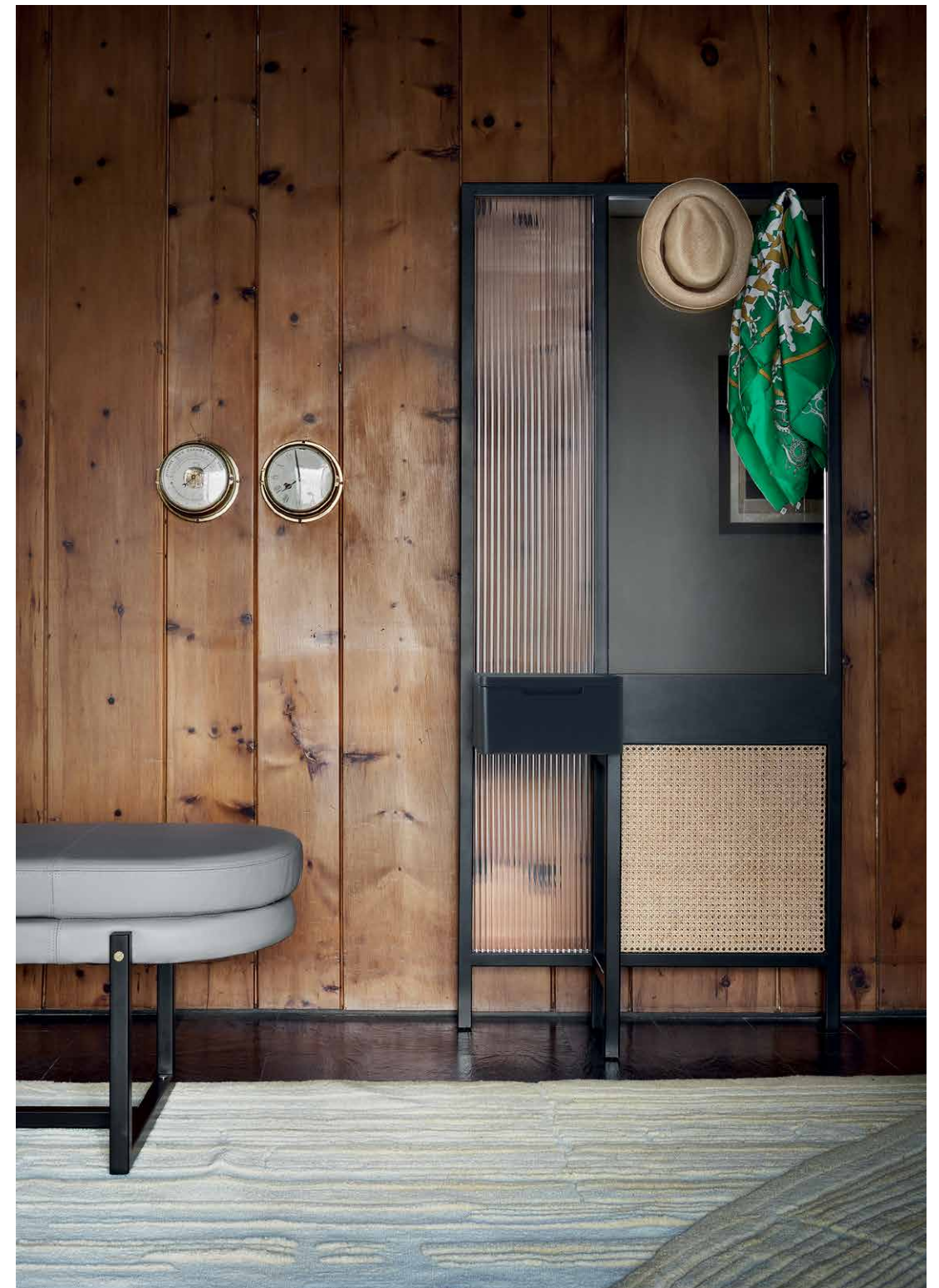

Threshold/high mirror cabinet
Sigmund/bench

Lee/Low Land

by *Fabrizio Ballardini*

L'immagine semplice rende il divano rassicurante nella sua contemporaneità. Le collezioni Lee e Low Land sono un sistema di sedute componibili, che permettono l'adattamento a innumerevoli spazi d'arredo. The simple image makes the sofa reassuring in its contemporaneity. The collection Lee and Low Land are a modular seating system, that allow the adjustment to countless furnishing spaces.

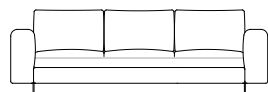

126/*designcollection*

Lee/sofa
composition L 07
Match/small table
Island/small table

127/*designcollection*

Lee/sofa
composition L 01
Cradle/small table





Lee/sofa
Goya/small table
9000/armchair



Low Land/sofa
Ladle/armchair
Island/small table
9000/pouf
Rubycon/sideboard

Ladle

by Luca Nichetto

Le poltrone Ladle vogliono rielaborare il design in chiave contemporanea, ma soprattutto la sensazione e il comfort delle poltrone classiche degli anni '60. Ladle (che significa mestolo), come il grande cucchiaino di legno, raccoglie la forma del corpo, regalando un comfort molto morbido e avvolgente. The armchairs Ladle want to re-edit the design with a contemporary point of view, but above all the feeling and the comfort of the 60' years classic armchairs. Ladle, like the big wooden spoon, collects the body shape, giving a very soft and embracing comfort.

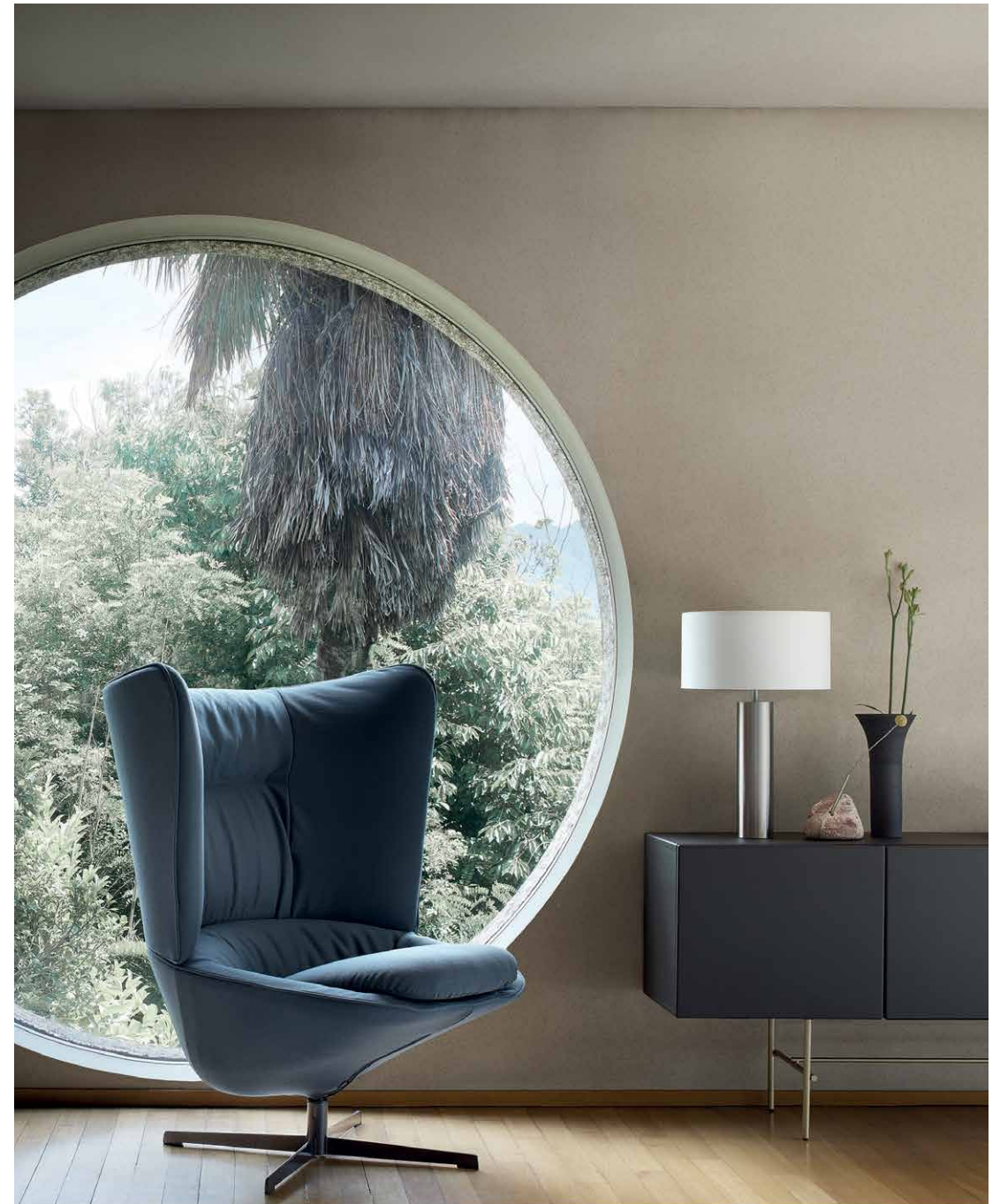



Ladle/armchair
Ladle/pouf,
Match/small table

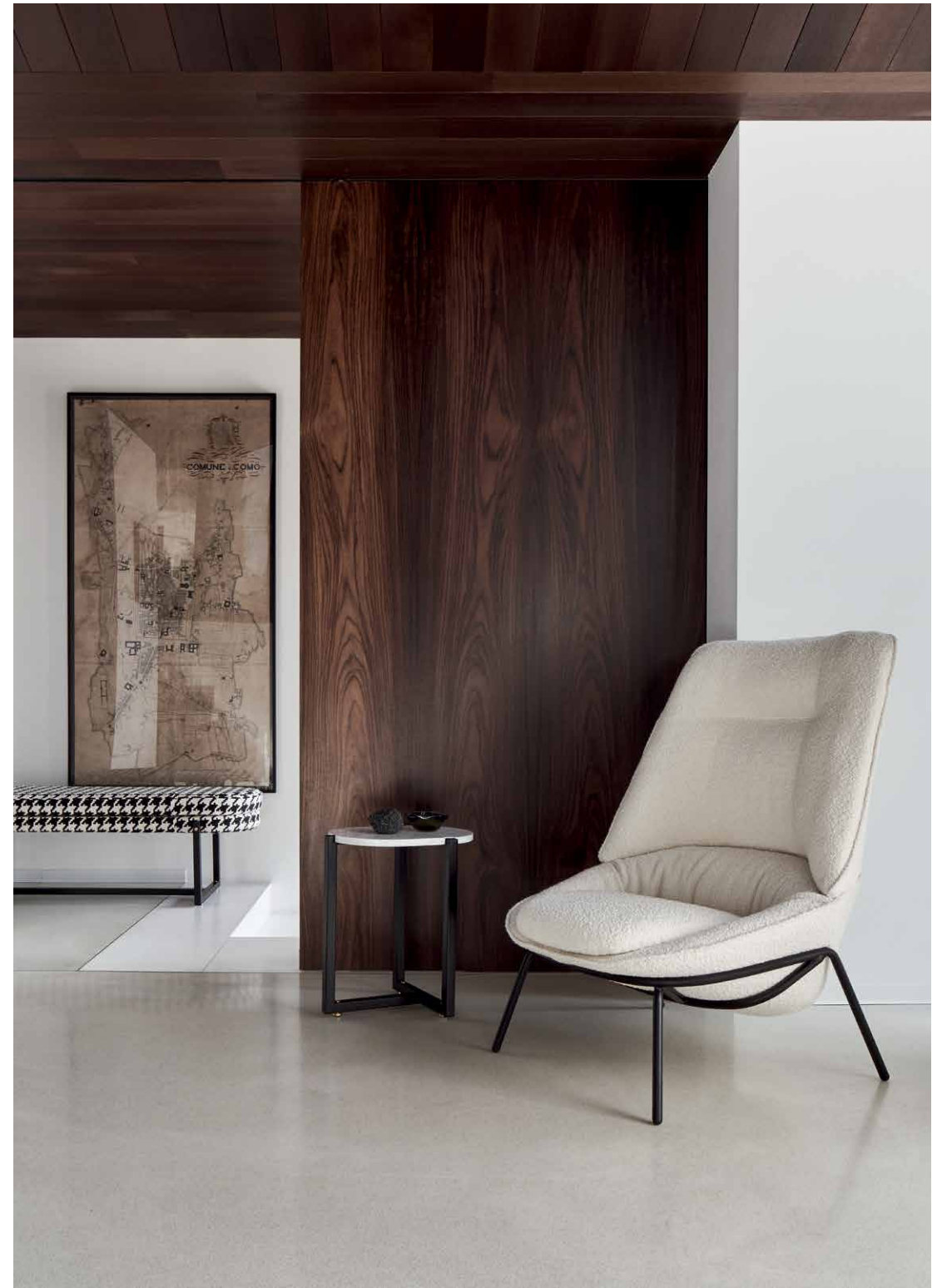

Ladle/armchair
Sigmund/bench
Sigmund/small table

Gloria

by Claesson Koivisto Rune

“Gloria è tutta incentrata sul suo vestito. Può sembrare elegante quando va al lavoro, vestirsi bene quando va a una festa o indossare qualcosa di comodo quando resta a casa. Vestila come vuoi che sia!”

“Gloria is all about her dress. She can look smart for when she goes to work, dress up when going to a party, or put on something cosy when staying in. Dressed her as you want her to be!”

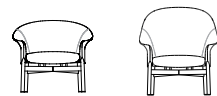
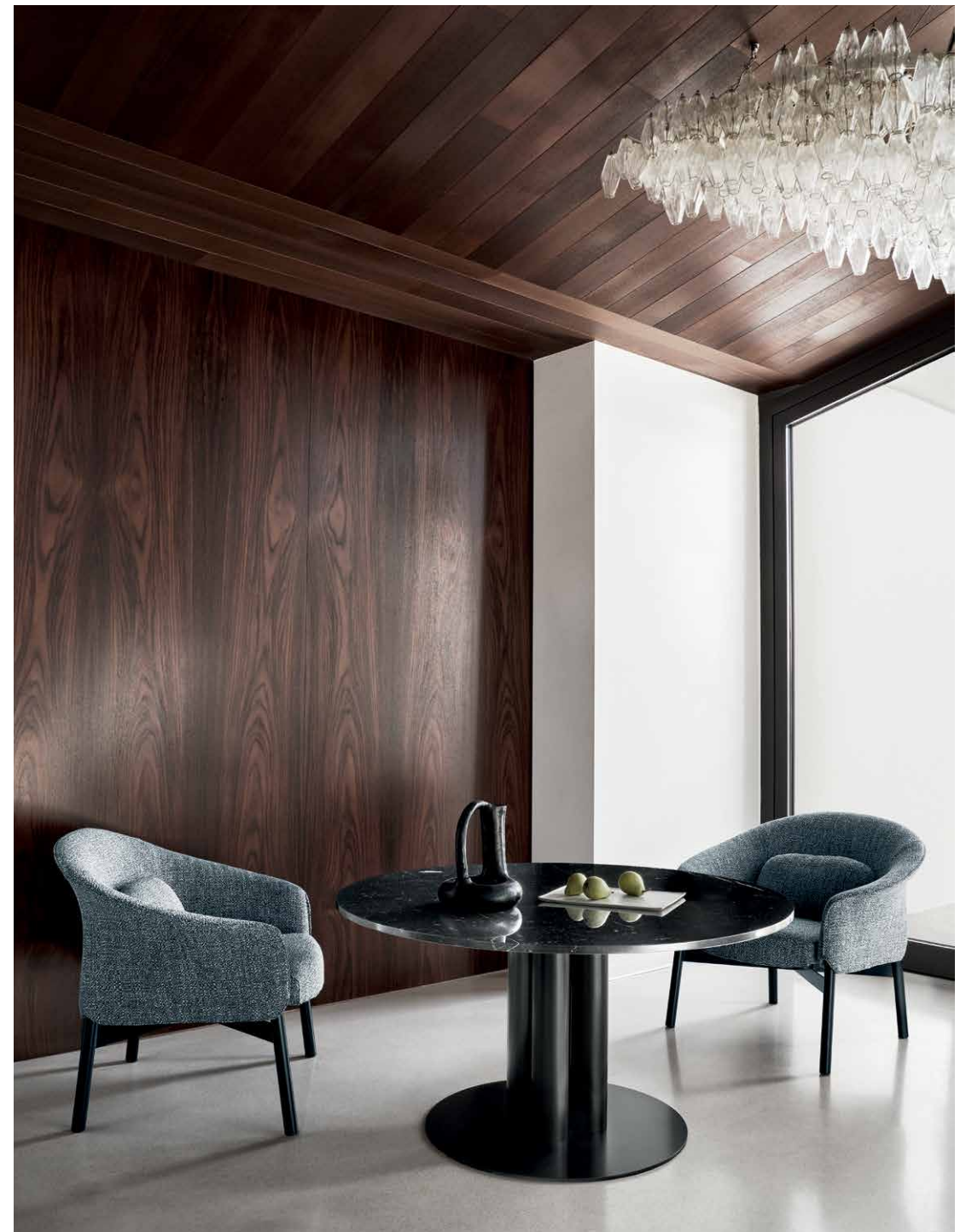

138/designcollection

Goya/table
Gloria/armchair

139/designcollection



140 / designcollection

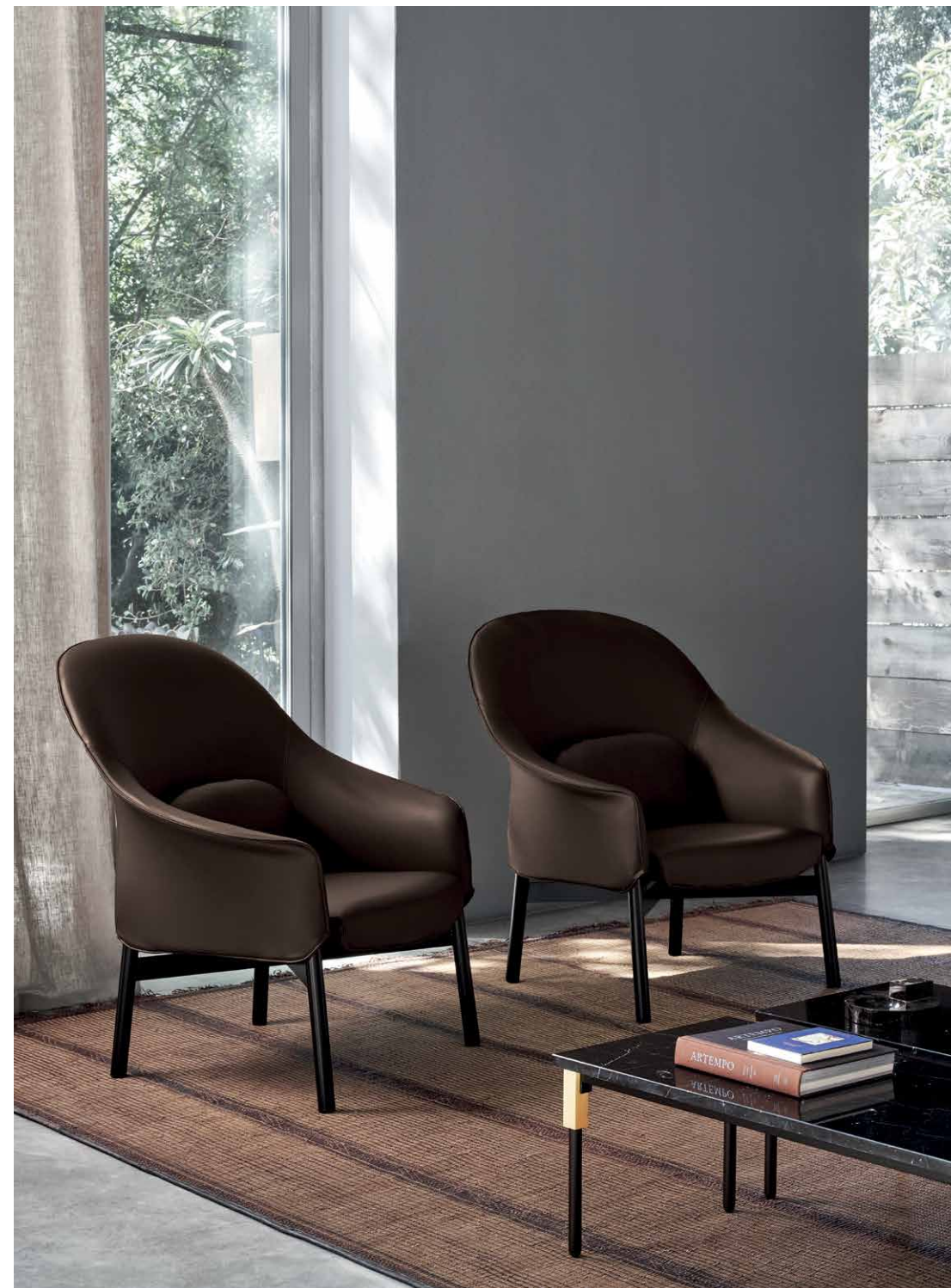

Gloria/armchair
Match/small table

141 / designcollection

Alba

by Bernhardt & Vella

Alba è una libreria per esporre e contenere, con una straordinaria versatilità creatrice. I ripiani in vetro colorato permettono di realizzare composizioni tonde, grazie al fissaggio con un unico elemento di giunzione. L'elemento semicerchio in vetro colorato aggiunge anche un decoro geometrico, oltre ad avere la funzione di riporre i libri. Alba is a bookcase for exhibiting and containing, with an extraordinary creating versatility. The coloured glass shelves allow to realize round compositions, thanks to the fixing with one single joining element. The coloured glass half circle-shape element adds also a geometric decoration, in addition to the function of hanging the books.

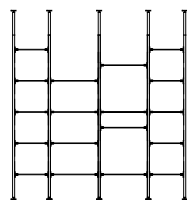

142/designcollection



Alba/bookcase
Delfino/pouf

143/designcollection



144/*designcollection*



Alba/bookcase
Goya/table
Marechiaro/sofa

145/*designcollection*

Arcolor

by Jaime Hayon

Per sviluppare il divano Arcolor di arflex, Jaime Hayon ha voluto creare un sistema modulare, disegnato intorno alla geometria classica dell'arco. To develop Arcolor sofa for arflex, Jaime Hayon wanted to create a modular system, designed around the classical geometry of the arch.

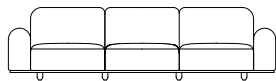

146/designcollection



Arcolor/sofa
composition AR 02
Gloria/armchair
capsule collection
Forest 01
category Leather "Super"
Arcolor/small table
Tablet/small table
Match/console

147/designcollection

Arcolor/sofa
composition AR 07
Arcolor/small table
Leafo/armchair



Arcolor/sofa
composition AR 03
Hug/armchair
Infinity/small table
Capilano/small table

Hug

by Claesson Koivisto Rune

Un gesto amichevole e di accoglienza, riconoscibile, che racchiude tutti gli aspetti e parla anche direttamente al cuore: l'abbraccio. Si vede più chiaramente nella posizione 'a braccia aperte' dei braccioli e vuole essere un invito universale: «Vieni, siediti un momento con me e ti metterò a tuo agio» (cit. Claesson Koivisto Rune). A friendly, welcoming, recognisable gesture, that encompasses all of the aspects and also speaks directly to the heart: the hug. It is more visible in 'open-armed' position of the armrests and it is meant as a universal invitation: «Come, sit with me a while and I'll put you at ease» (by Claesson Koivisto Rune).

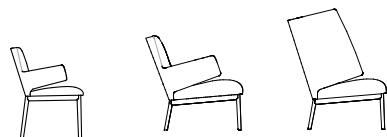

150/designcollection

Hug/armchair
Arcolor/small table

151/designcollection



Hug/armchair
Arcolor/small table
Elettra/chair



Hug love seat/sofa

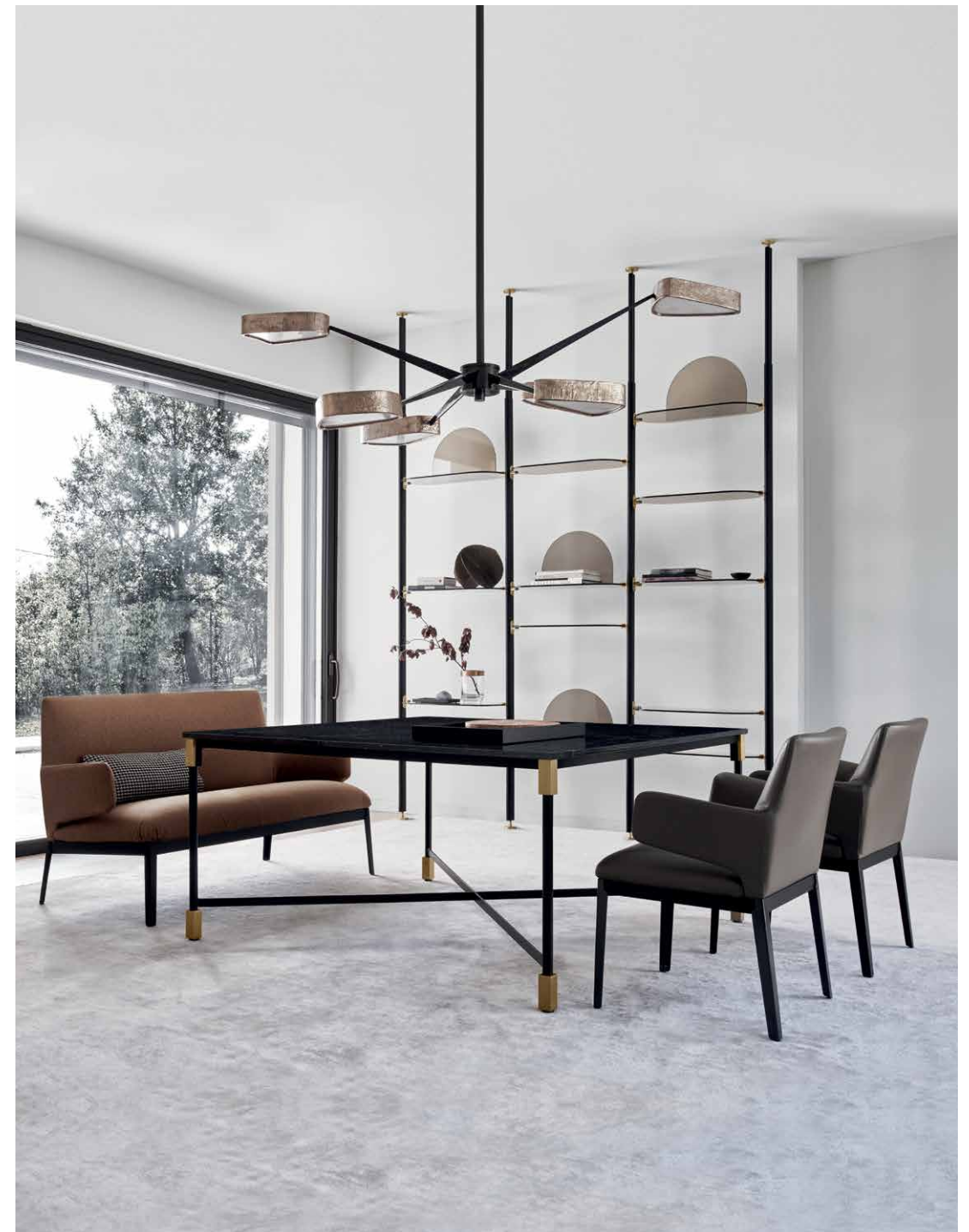

Hug/chair
Alba/bookcase
Hug love seat/sofa

Naviglio

by Umberto Asnago

Il sistema di sedute Naviglio è contraddistinto da una forma rigorosa, ma piacevolmente addolcita nelle linee, grazie ad un sapiente uso dei materiali. Un divano lineare e componibile, caratterizzato da un'estetica leggera e generosa, che lo rende comodo nelle proporzioni e negli spazi. The seating system Naviglio is characterized by rigorous shape, but pleasantly softened in the lines, thanks to a competent use of the materials. A linear and modular sofa, distinguished by a light and generous aesthetic, which makes it comfortable in the proportions and in spaces.

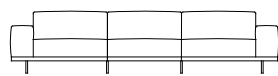

156 / designcollection



Naviglio/sofa
Bonsai/small table

157 / designcollection



Naviglio/sofa
Bonsai/small table
Neptunia/chair
Pouf



Naviglio/sofa
Cross/armchair
Goya/small table

Pecorelle

by Cini Boeri

L'architetto Cini Boeri racconta di essersi ispirata alle opere di Christo Vladimirov Javacheff e Jeanne-Claude Denat de Guillebon, maestri nell'arte della pittura di paesaggio. La natura prevale e diventa la musa ispiratrice di questo pezzo di design. The architect Cini Boeri tells that she was inspired by the works of Christo Vladimirov Javacheff and Jeanne-Claude Denat de Guillebon, masters in the art of landscape painting. Nature prevails and becomes the inspiring muse of this piece of design.

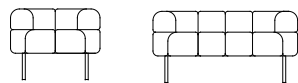

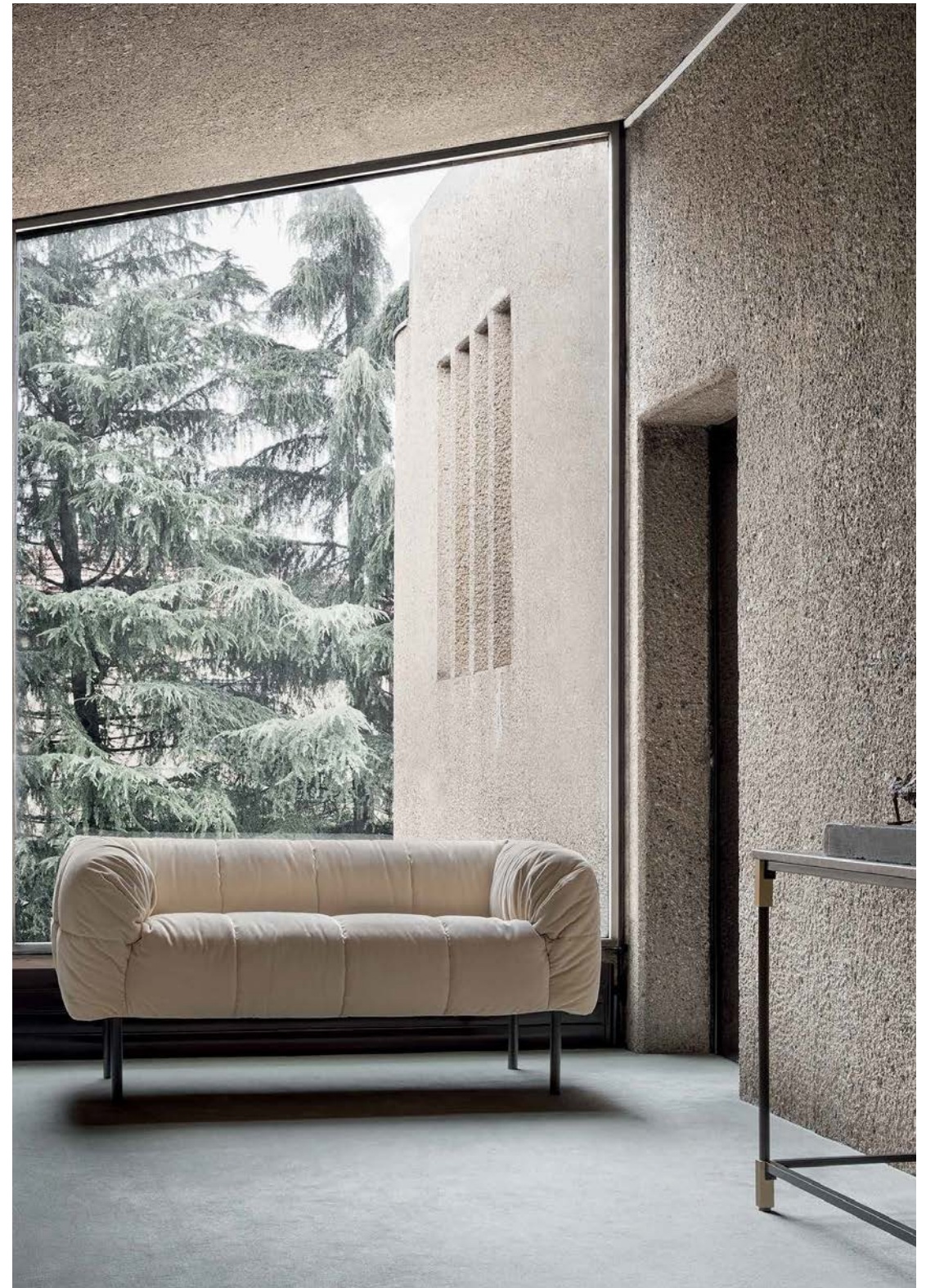

Match

by *Bernhardt & Vella*

Il progetto nasce da un insieme industriale di ripiani. Lo snodo in ottone, che unisce la struttura alla mensola, diventa un elemento prezioso e decorativo. Il sistema può essere impilato e con gli stessi elementi si possono creare tavolini, console e librerie di diverse altezze. The project was born from an industrial shelves system. The junction in brass, that joins the structure with the shelf, becomes a precious and decorative element. The pieces can be stacked and allows to create with the same elements also small tables, console and bookshelves with different heights.

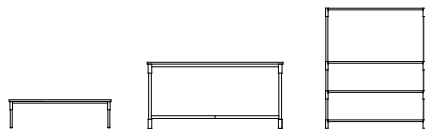

166/*design.collection*

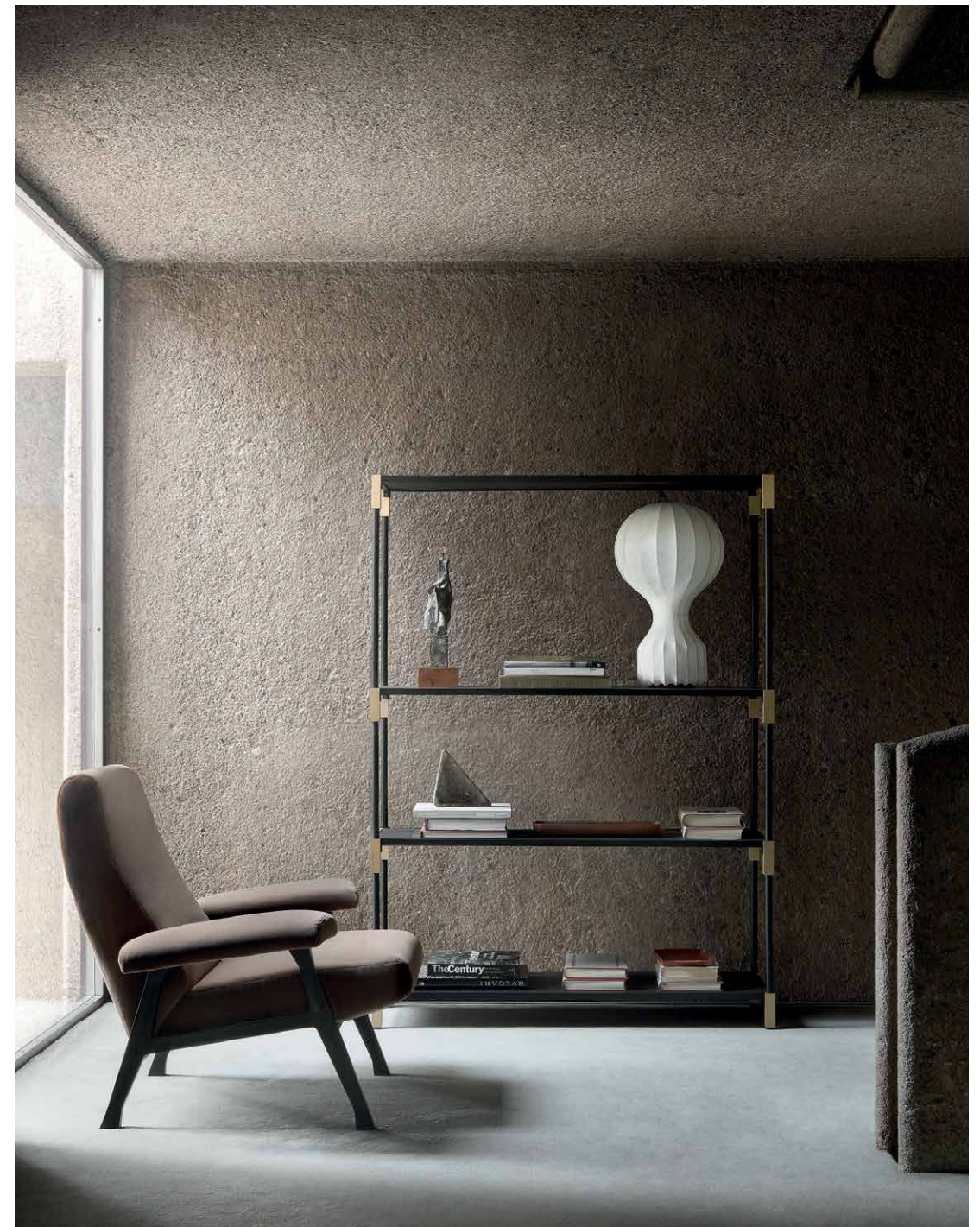

Match/bookcase
Hall/armchair

167/*design.collection*



Match/bookcase
Tellin/armchair

168/*design.collection*

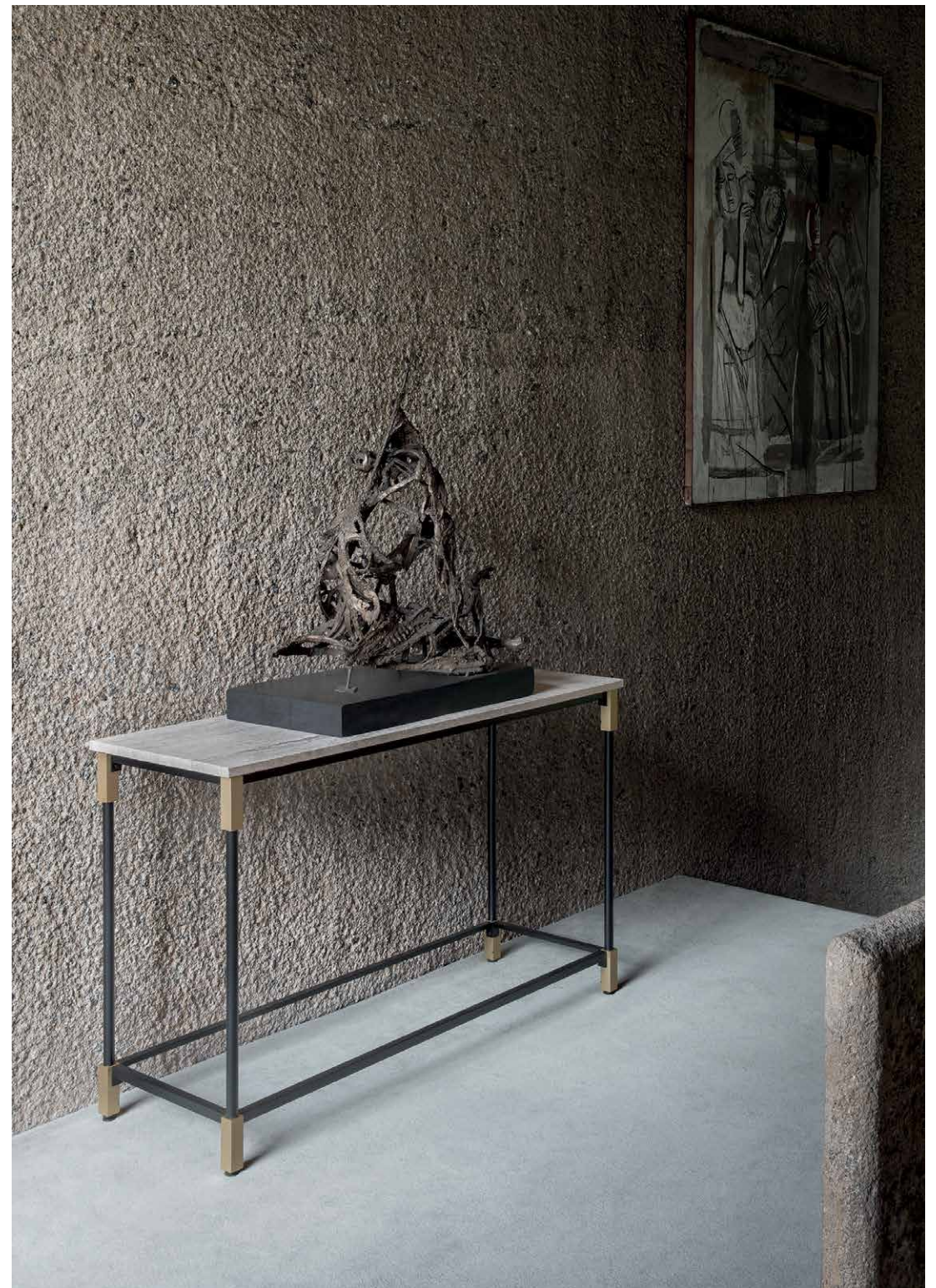

Match/console

169/*design.collection*



Match/small table

170/designcollection



Botolo/armchair
Alba/bookcase

171/designcollection

Botolo

by Cini Boeri

Cini Boeri disegna Botolo nel 1973, dando vita ad un nuovo stile di design, dove si può scegliere l'altezza delle gambe per avere una poltrona pranzo nella versione alta o uno stile, allora moderno, "il living a basso livello", un modo di vivere e di sedersi per terra. Nelle gambe ci sono delle ruote per spostarla facilmente. Cini Boeri designed Botolo in 1973, giving life to a new design style, where you could choose the height of the legs to have a dining armchair in the high version or a style, at that time modern, "the living at a low level", a way of living and sitting on the ground. In the legs there are wheels to move it easily.

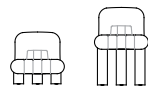
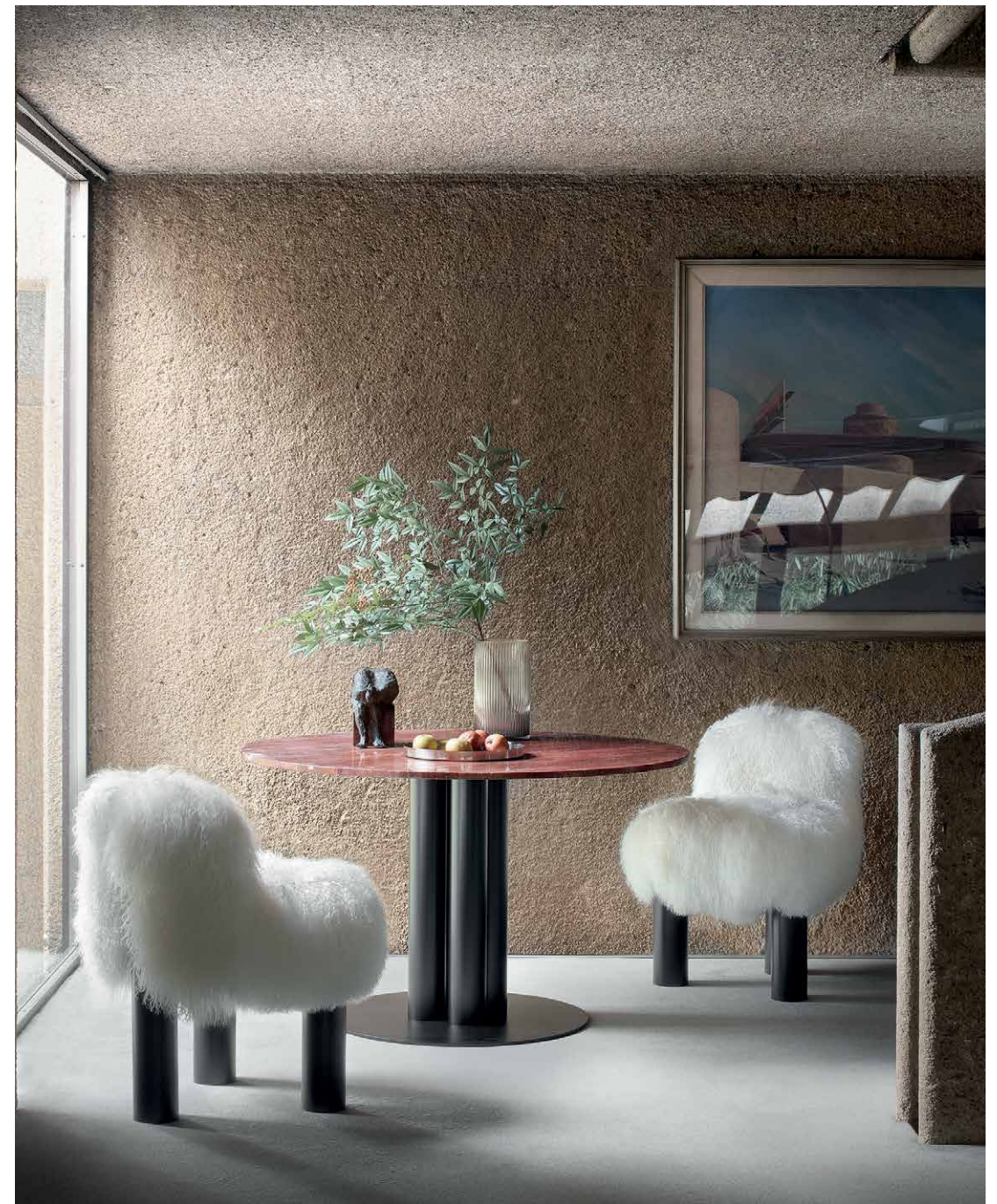

172/designcollection

Goya/table
Botolo/armchair

173/designcollection



174/*designcollection*

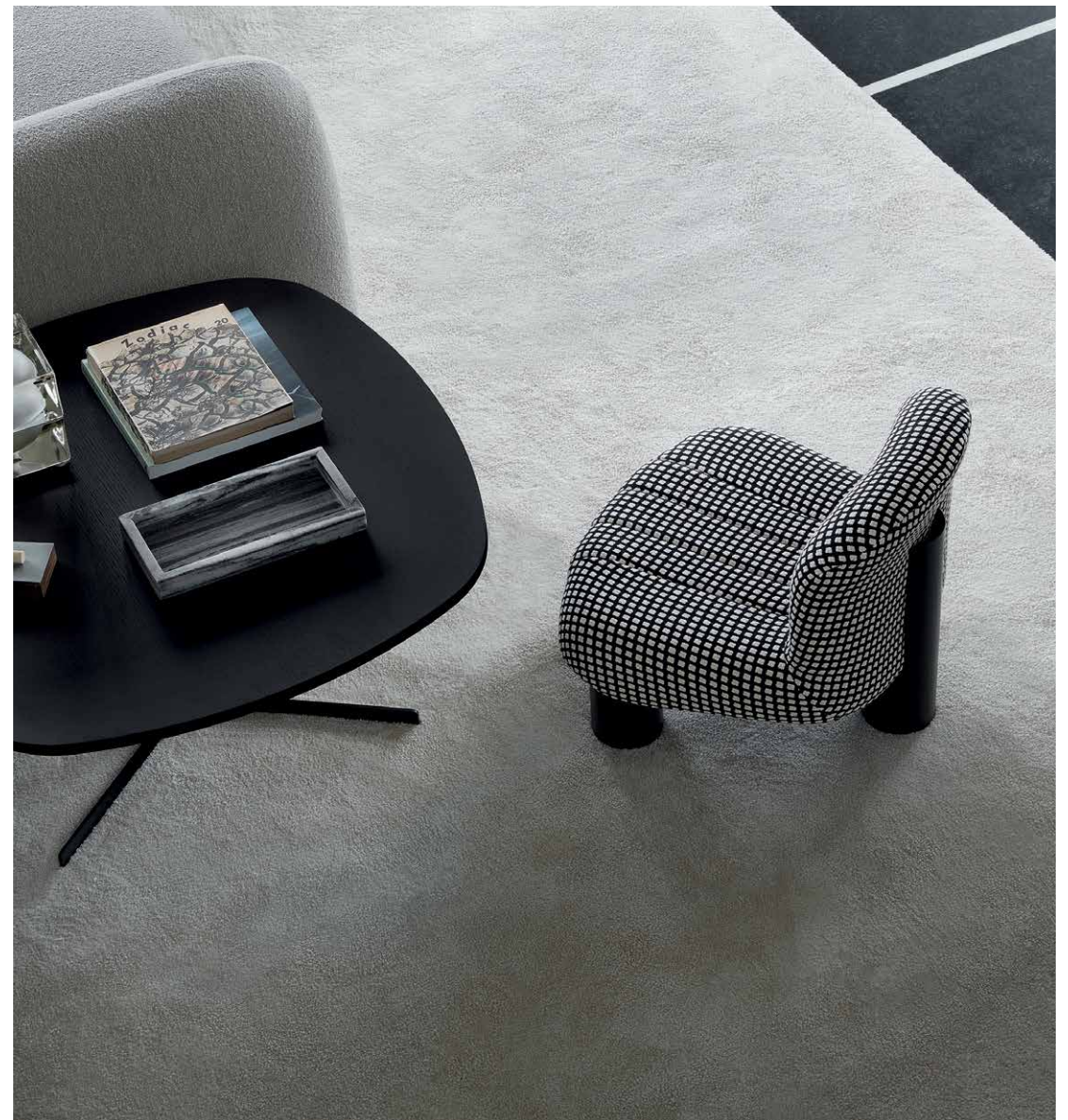

Botolo/armchair
Island/small table

175/*designcollection*



176/*designcollection*

Botolo/armchair
Vela/screen
Match/console



177/*designcollection*

Cousy

by Vincent Van Duysen

Cousy, disegnato da Vincent Van Duysen, è un divano caratterizzato da linee leggere e proporzionate, che lo rendono adatto a tutti i tipi di living. Un divano dalla struttura minimalista e rigorosa, con un effetto confortevole e decorativo allo stesso tempo. Cousy, designed by Vincent Van Duysen, is a sofa characterised by light and proportional lines, that make it suitable for all types of living. A sofa with a minimalist and rigorous structure, for a comfortable and decorative effect at the same time.

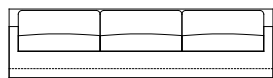

178/designcollection

Cousy/chaise longue
Sigmund/small table

179/designcollection



Cousy/sofa
Elettra/armchair
Tellin/armchair
Tablet/small table



Leafo

by Jaime Hayon

Una sedia semplice, che può essere collocata in piccoli e grandi spazi. La particolare forma si ispira a una foglia che cade da un albero, che diventa simbolo di comfort. Ti invita a riposarti e rilassarti. L'ergonomia dello schienale fornisce un ottimo sostegno per la schiena, consentendo una posizione seduta, classificabile tra sedia e chaise longue. A simple chair, that can be placed in small and large spaces. The special shape is inspired by a leaf falling from a tree, that becomes a symbol of comfort. It invites you to take a rest and relax. The ergonomics of the backrest provides excellent support for the back, allowing a sitting position, that can be classified between a chair and a chaise longue.



184/designcollection

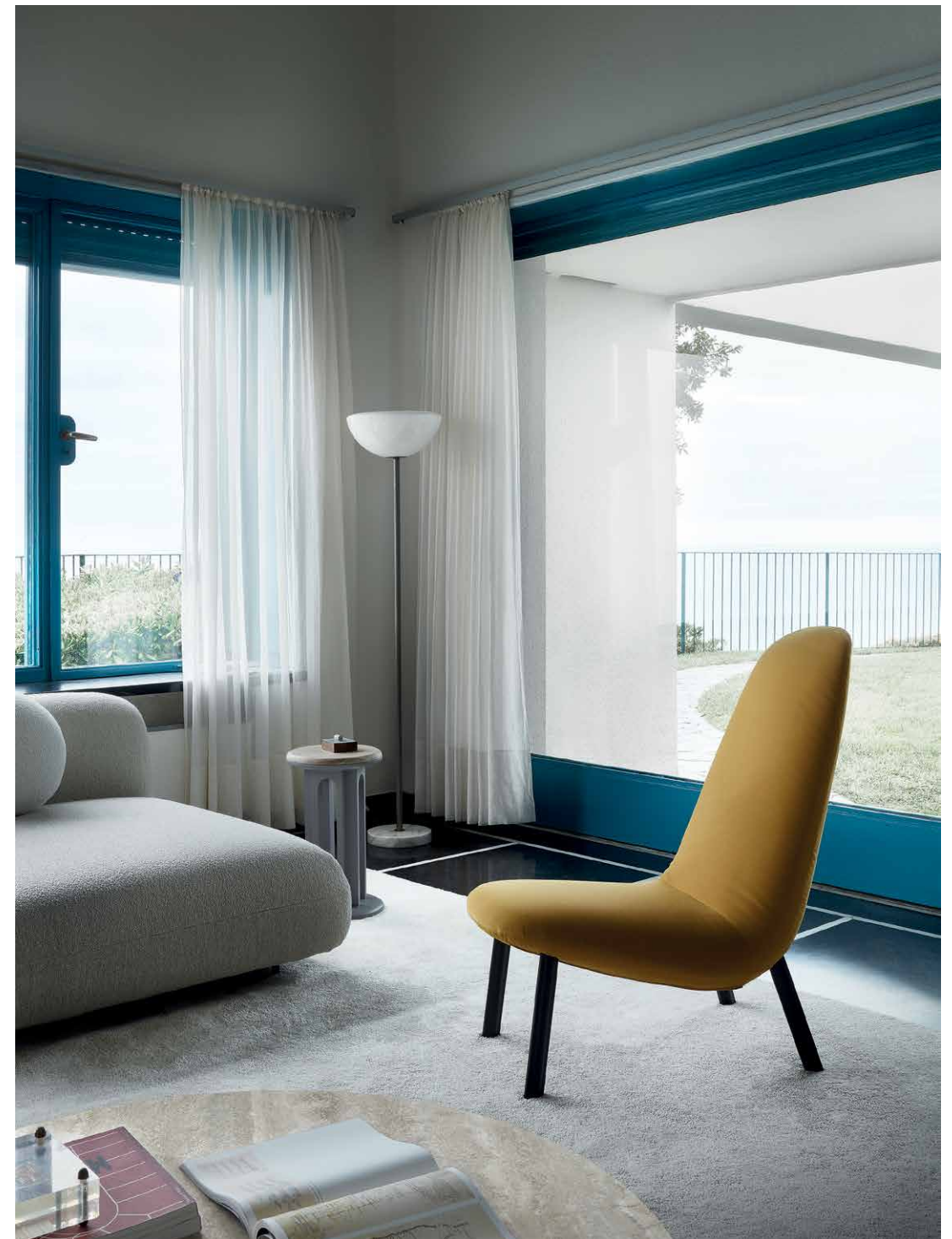

Leafo/armchair
Arcolor/small table
Tokio/sofa

185/designcollection



186/*design.collection*

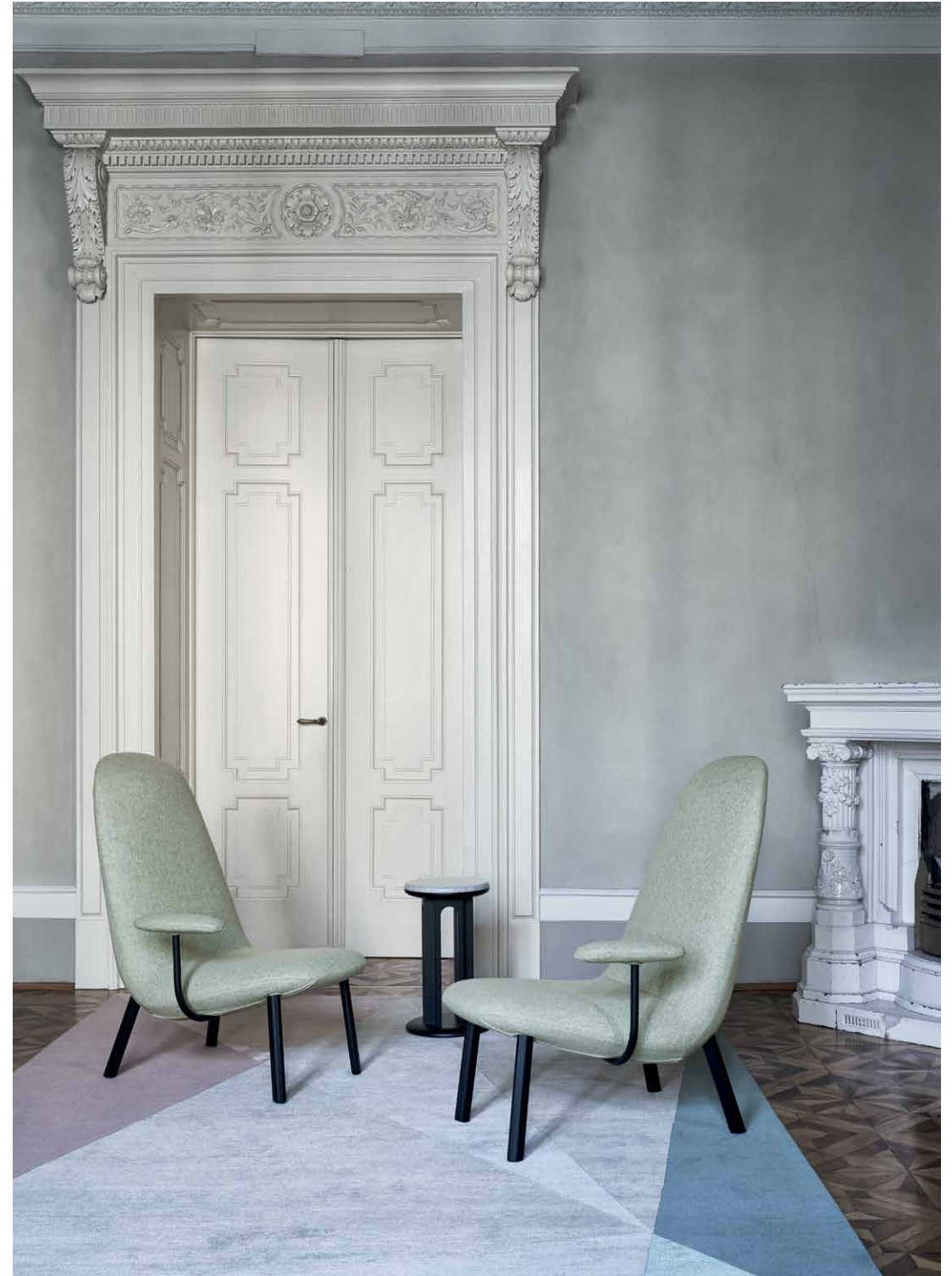

Leafo/armchair
Arcolor/small table

187/*design.collection*

Hall

by Roberto Menghi

Siamo alla fine degli anni '50: un'interessante serie di poltrone e divani, disegnata da Roberto Menghi, denominata Hall, entra a far parte della collezione arflex. In questi anni, il design tende a non essere solo per "élite". La nascita di altre testate sulla scia di Domus, Triennale, le mostre specializzate riescono ad aumentare strati più ampi di distributori e pubblico. La poltrona Hall riceve nel 1959 la menzione d'onore per il Compasso d'Oro. We are at the end of the '50s: an interesting series of armchairs and sofas, designed by Roberto Menghi, called Hall, joins arflex collection. In these years, the design tends not to be only for "élite". The birth of other magazines in the wake of Domus, Triennale, the specialized exhibitions manage to raise wider layers of distributors and audience. The armchair Hall receives in 1959 the honourable mention for Compasso d'Oro.



Hall/armchair
Marenco/sofa
Match/small table



Hall/armchair

190/designcollection



Hall/sofa
Tablet/small table
Match/small table

191/designcollection

Jim & Jules

by Claesson Koivisto Rune

Prendendo il nome dal famoso film francese di Francois Truffaut, Jules & Jim sono due poltroncine con un alto grado di comfort di seduta. Jules è la più piccola e Jim quella più grande. Nonostante la differenza di dimensioni, entrambe le poltrone condividono la stessa forma (geometria rotonda), che le rende facili da usare e da collocare in un contesto architettonico.

Named after the famous French movie by Francois Truffaut, Jules & Jim are two easy chairs with a high degree of seating comfort. Jules is the smaller and Jim the larger one. Though the difference in size, both armchairs share the same shape (round geometry), which makes them easy to use and place in an architectural context.

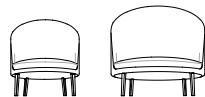

192/designcollection



Jules/armchair
Arcolor/small table

193/designcollection



Jim/armchair

194/designcollection



Jim/armchair
Jules/armchair

195/designcollection

Cross

by Marcello Cuneo

La poltrona nasce da un'idea molto semplice: due tubi piegati a forma di U e collegati tra loro da un incastro in lega leggera. Sulle due strutture, le fodere sono infilate e portano i cuscini della seduta e dello schienale. L'architetto ebbe una menzione speciale al XII Compasso d'Oro, nel 1979, per questa idea intuitiva. The armchair was born from a very simple idea: two tubes bent into a U shape and linked together by a light alloy joint. On the two structures, the covers are slipped into and carry the cushions of the seat and backrest. He had a special mention at XII Compasso d'Oro, in 1979, for this intuitive idea.

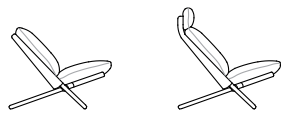

196/designcollection

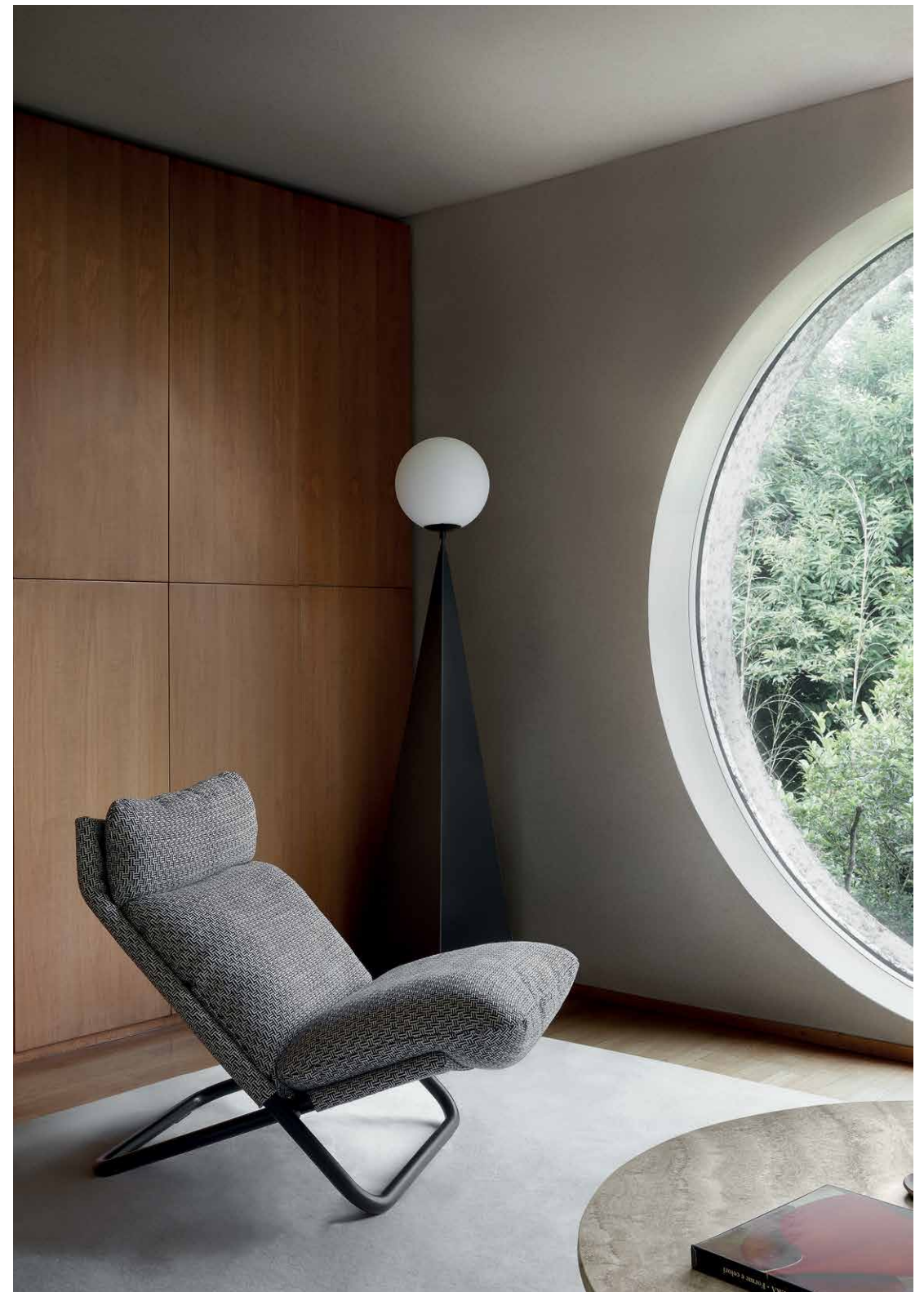

Cross/armchair

197/designcollection



Sigmund

by Studio Asai

Dedicata a Freud e ispirata alla lettura come rivelazione dell'immaginazione, la collezione Sigmund si compone inizialmente di due elementi: un daybed e una panca. Poi, come variazione sullo stesso tema, la sua estensione di design si completa con una scrivania e dei tavolini. Dedicated to Freud and inspired by reading as a revelation of the imagination, Sigmund collection initially consists of two pieces of furniture: a daybed and a bench. Then as a variation on the same theme, its design extension is completed with a desk and small tables.

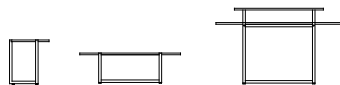

200/designcollection



Sigmund/writing desk
Botolo armchair
capsule collection
Forest 01 category
Leather "Super"

201/designcollection

Sigmund/small table
Sigmund/bench



202/ *designcollection*

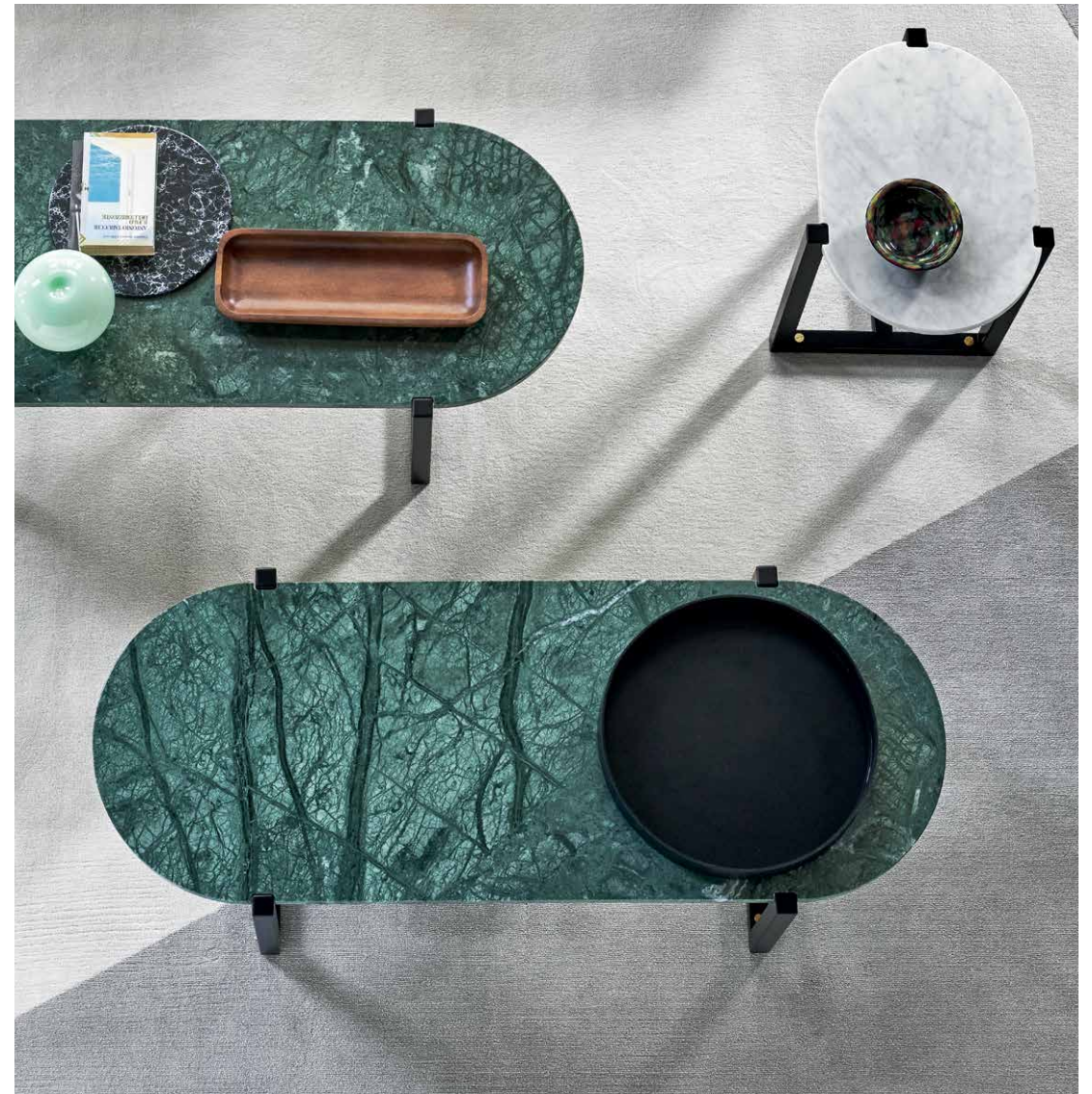

Sigmund/small table

203/ *designcollection*

Sigmund

by Studio Asai

Dedicata a Freud e ispirata alla lettura come rivelazione dell'immaginazione, la collezione Sigmund si compone inizialmente di due elementi: un daybed e una panca. Poi, come variazione sullo stesso tema, la sua estensione di design si completa con una scrivania e dei tavolini. Dedicated to Freud and inspired by reading as a revelation of the imagination, Sigmund collection initially consists of two pieces of furniture: a daybed and a bench. Then as a variation on the same theme, its design extension is completed with a desk and small tables.

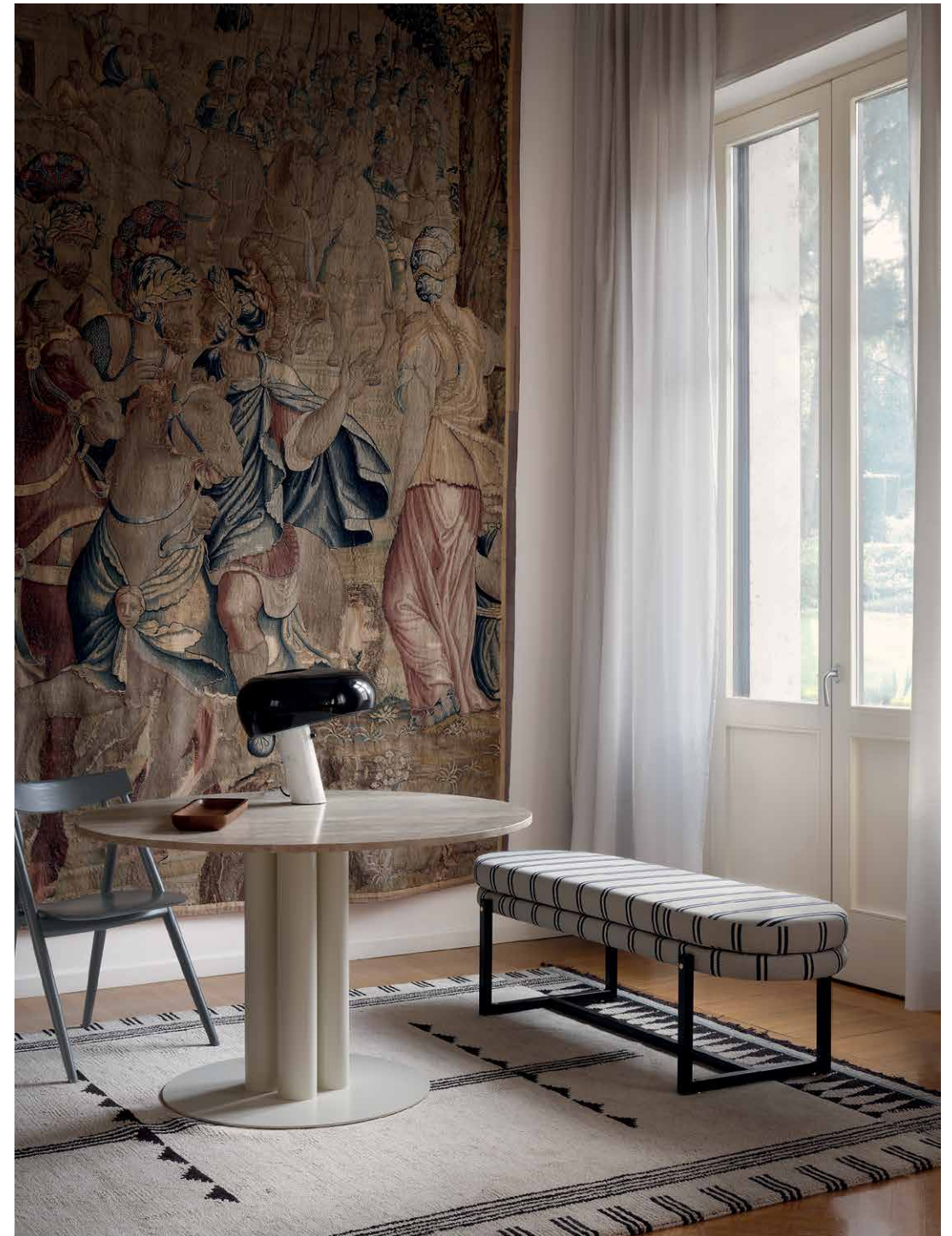

204/designcollection

Sigmund/bench
Goya/table
Lizzy/chair

205/designcollection

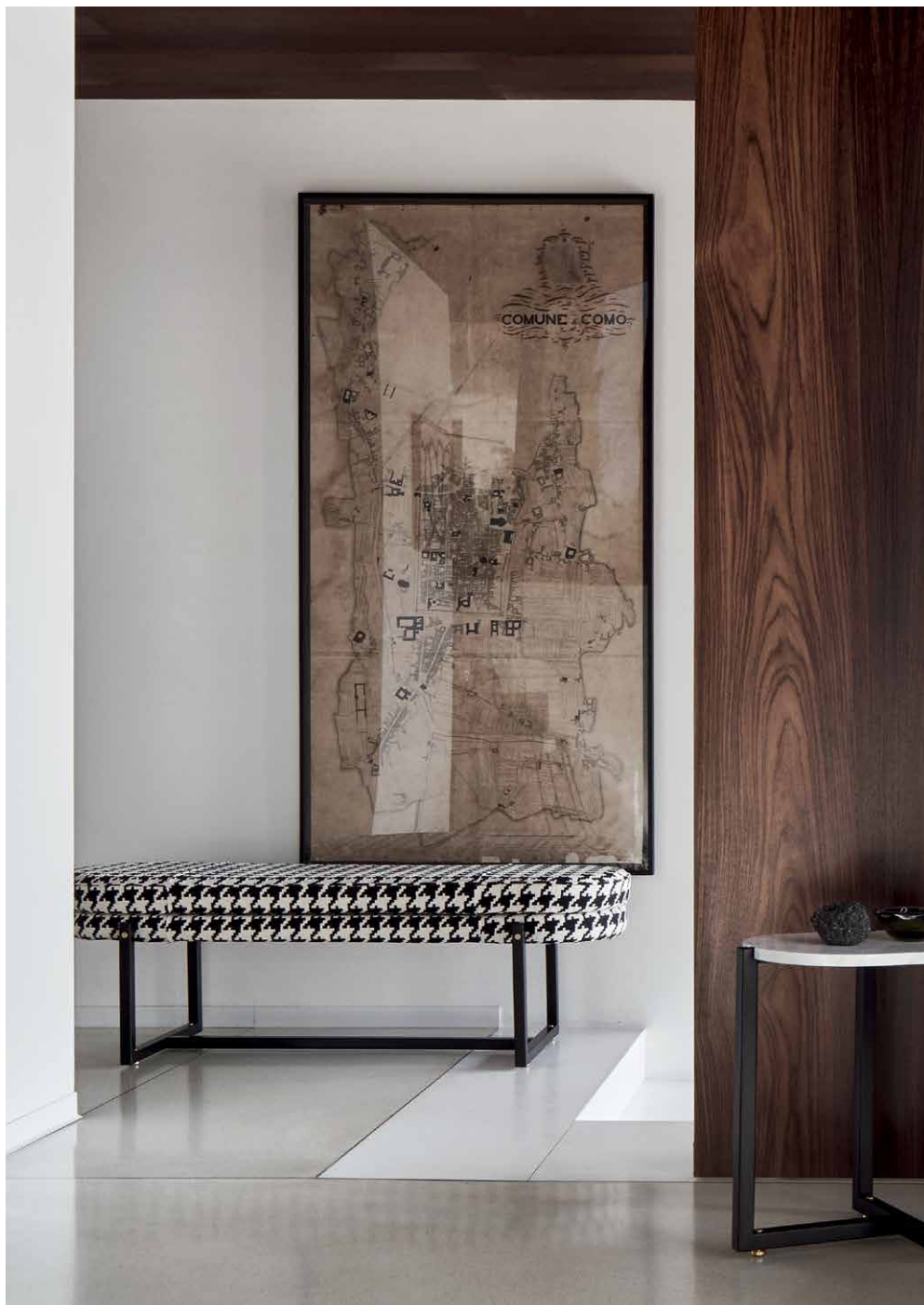

Sigmund/bench
Sigmund/small table

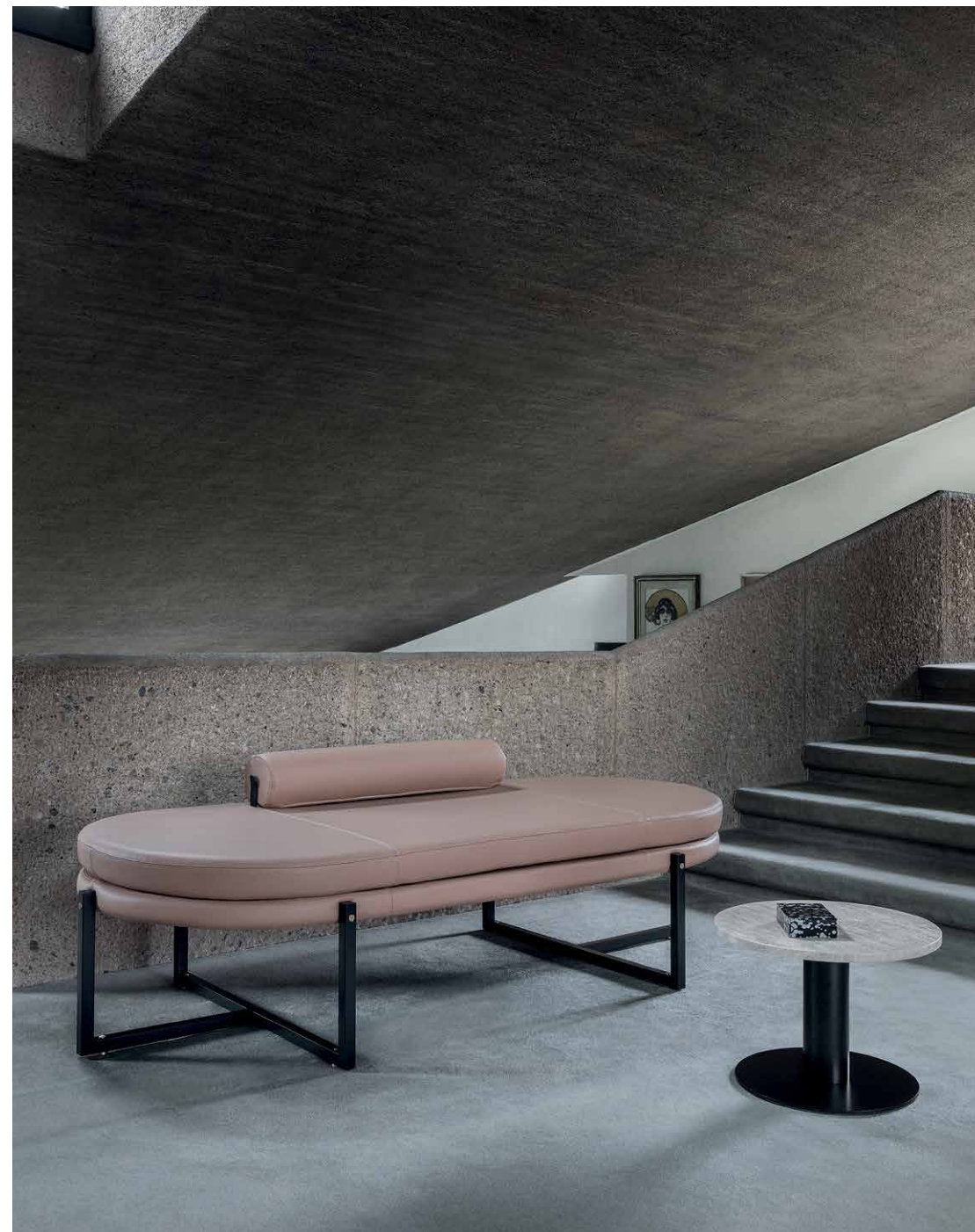

Sigmund/daybed
Goya/small table

Hug

by Claesson Koivisto Rune

I designer Claesson Koivisto Rune hanno arricchito la famiglia Hug. Partendo dall'idea iniziale, hanno creato un tavolo dal design lineare e pulito, ma ricco di dettagli costruttivi, che può essere inserito in ambienti sofisticati ed eleganti. The designers Claesson Koivisto Rune have enhanced Hug family. Starting from the initial idea, they created a table with a linear and clean design, but rich in construction details, which can be placed into sophisticated and elegant environments.



208/designcollection

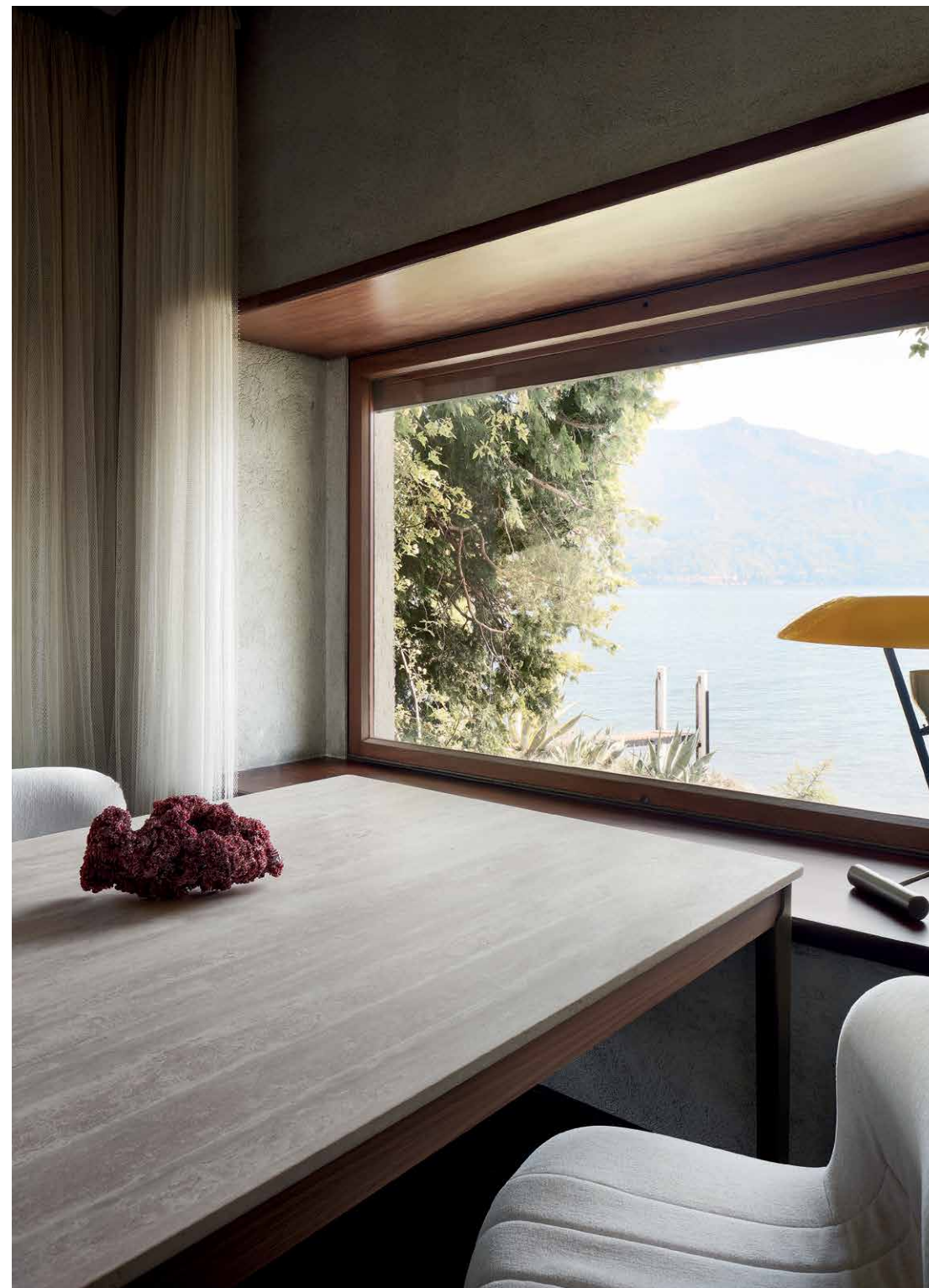

Hug/table
Botolo/armchair

209/designcollection



210/*designcollection*

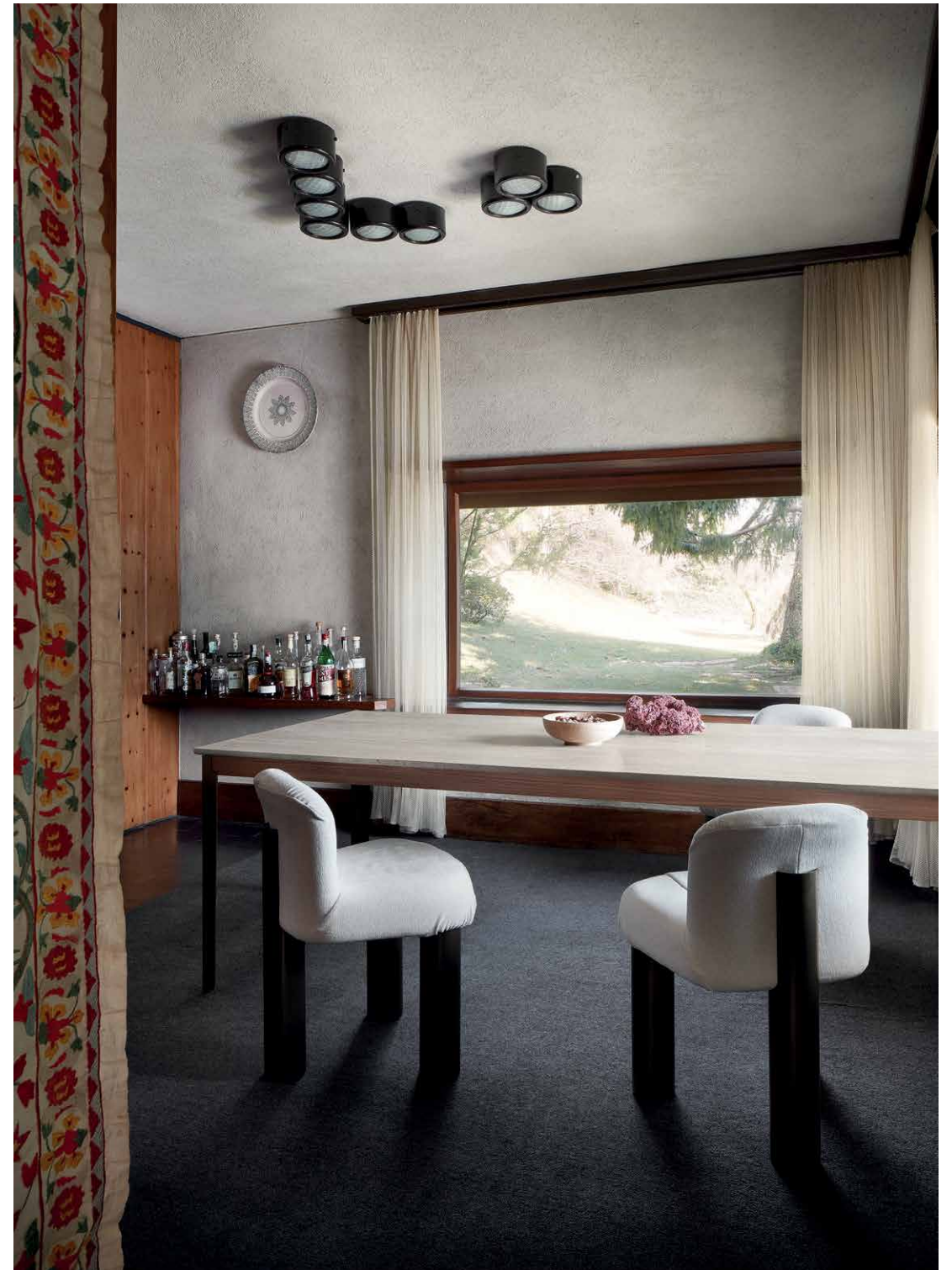

Hug/table
Botolo/armchair

211/*designcollection*



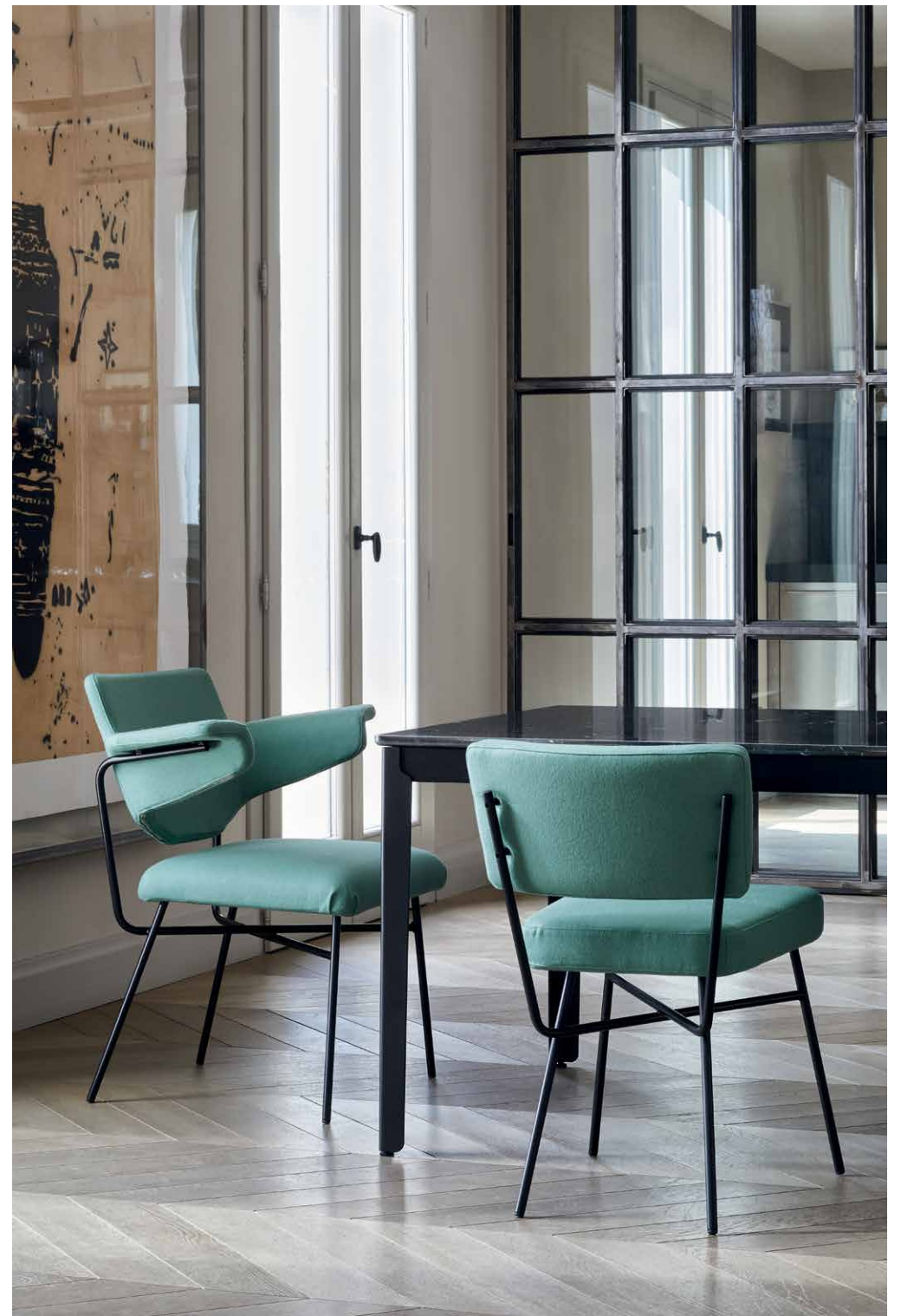

214/*designcollection*

Neptunia/chair
Hug/table
Elettra/chair

215/*designcollection*



216/*design.collection*

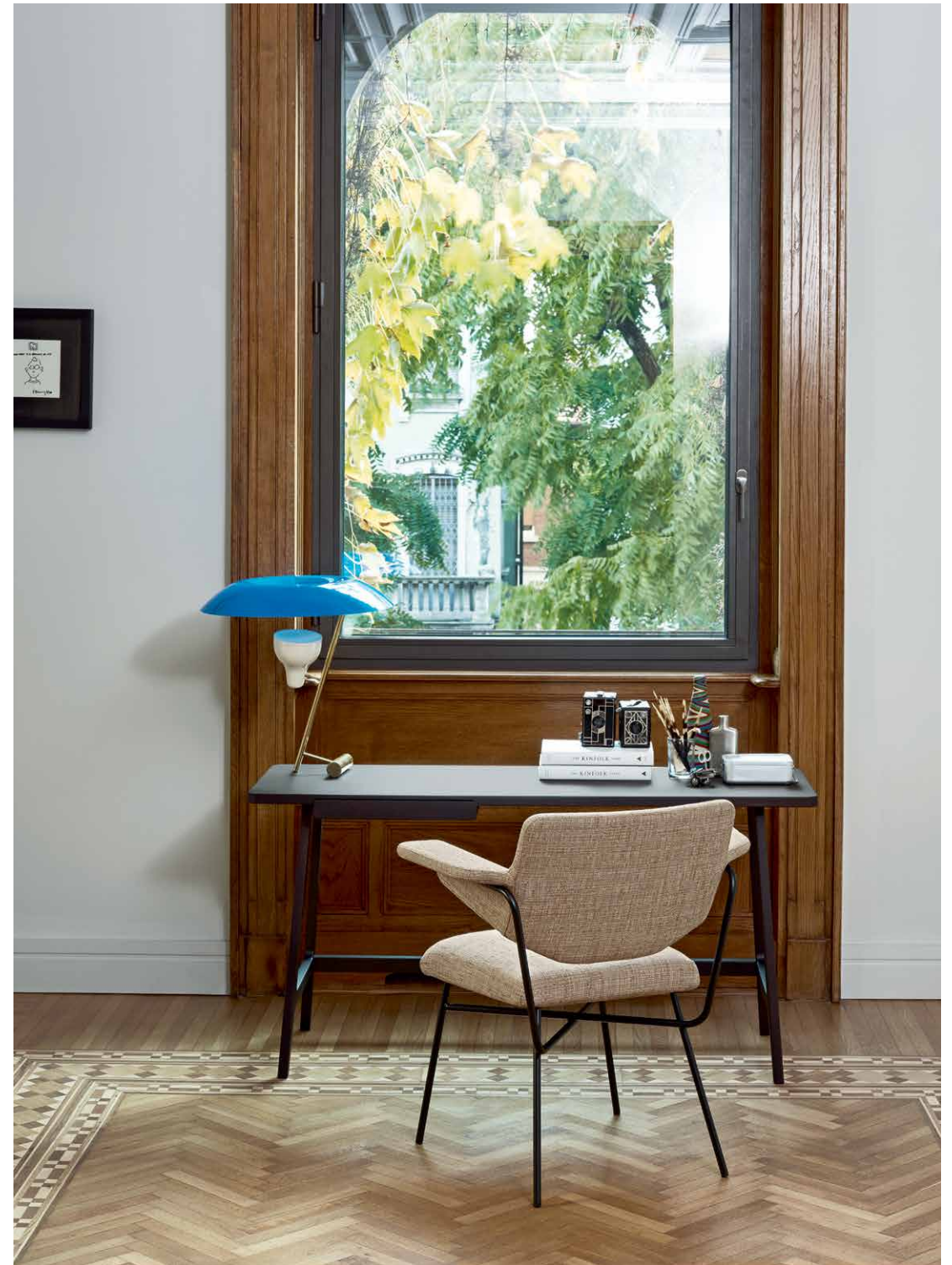

Neptunia/chair
Ponti/writing desk

217/*design.collection*

Elettra

by B.B.P.R.

Il primo grande progetto progettuale di B.B.P.R. risale al 1946, dopo la parentesi bellica e la pianificazione della ricostruzione per Milano. Accanto ai mobili per la casa, gli anni '50 vedono anche la realizzazione dei primi arredi per uffici e spazi pubblici, come il modello Elettra. B.B.P.R.'s first major design project dates back to 1946, after the war interlude and the reconstruction planning for Milan. Alongside furniture for home, the 1950s also saw the creation of the first furnishings for offices and public spaces, such as Elettra model.

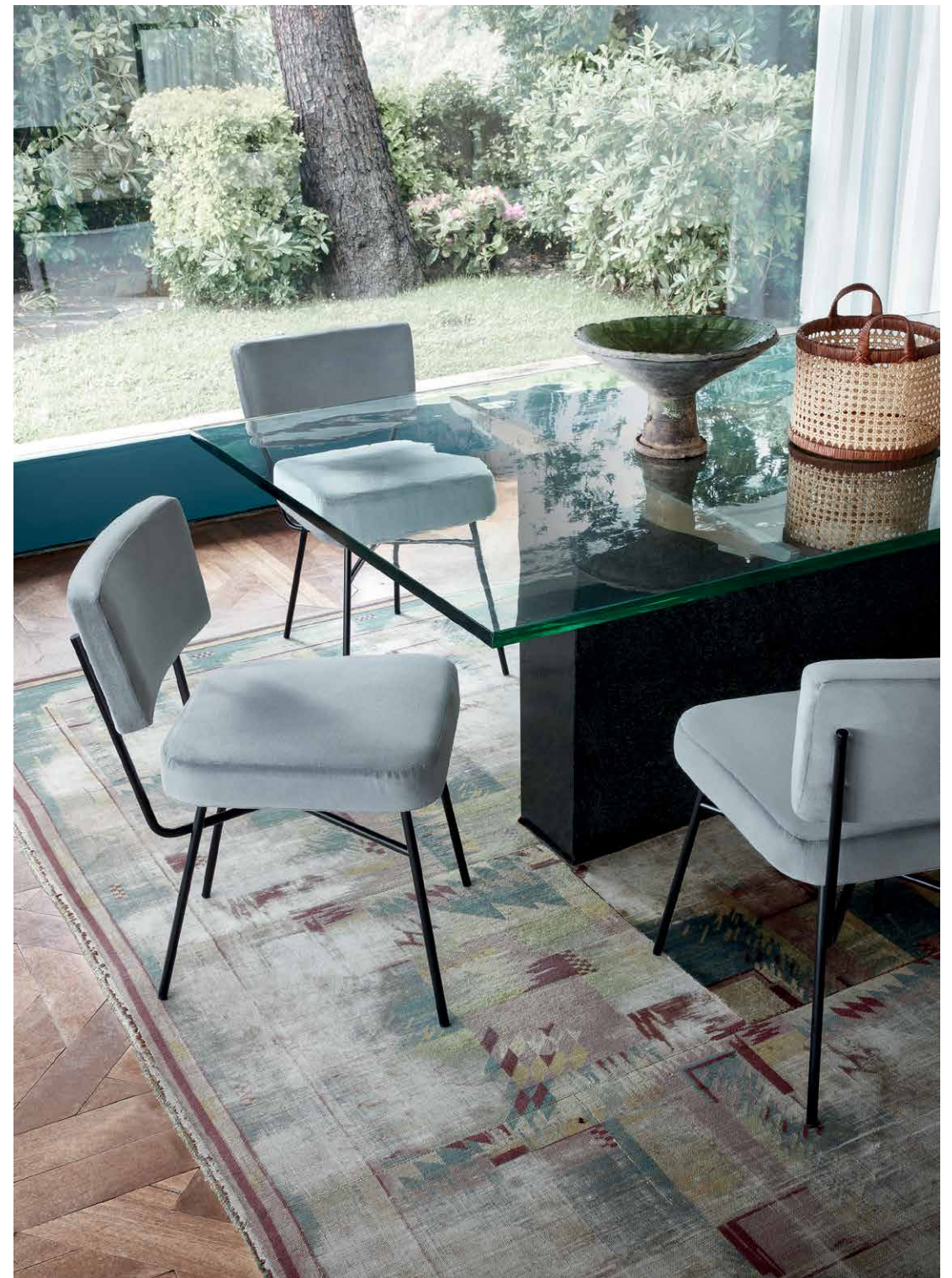



220/designcollection



Elettra/chair
Diva/screen
capsule collection
Palmette 01

221/designcollection



222/designcollection



Orfeo/stool

223/designcollection

Ponti

by Claesson Koivisto Rune

Ispirandosi all'elegante bellezza dei ponti e alle opere del famoso designer milanese omonimo, è stato progettato uno scrittoio dalle linee nette e ordinate, al tempo stesso rigorose e squadrate. Inspired by the elegant beauty of bridges and by the works of the famous Milanese designer with the same name, a writing desk was designed, having clear and tidy lines, at the same time rigorous and squared.

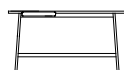

224/designcollection

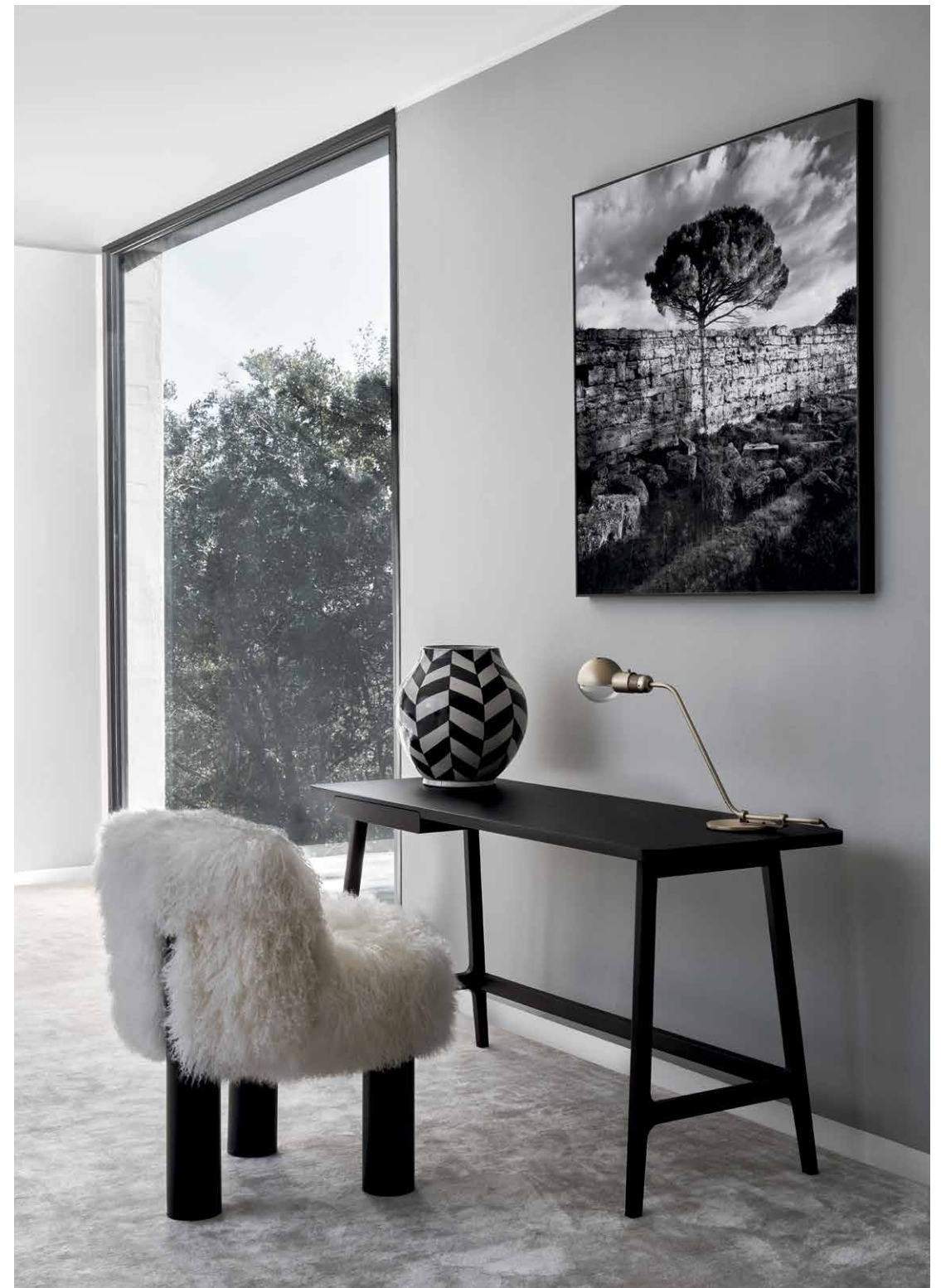

Botolo/armchair
Ponti/writing desk

225/designcollection

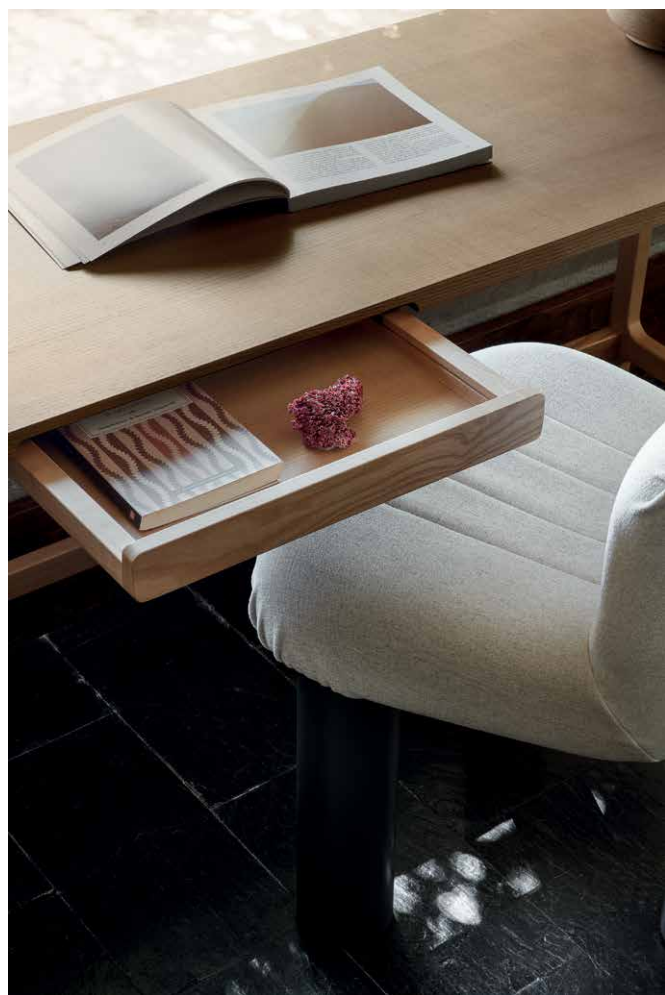

Ponti/writing desk
Botolo/armchair

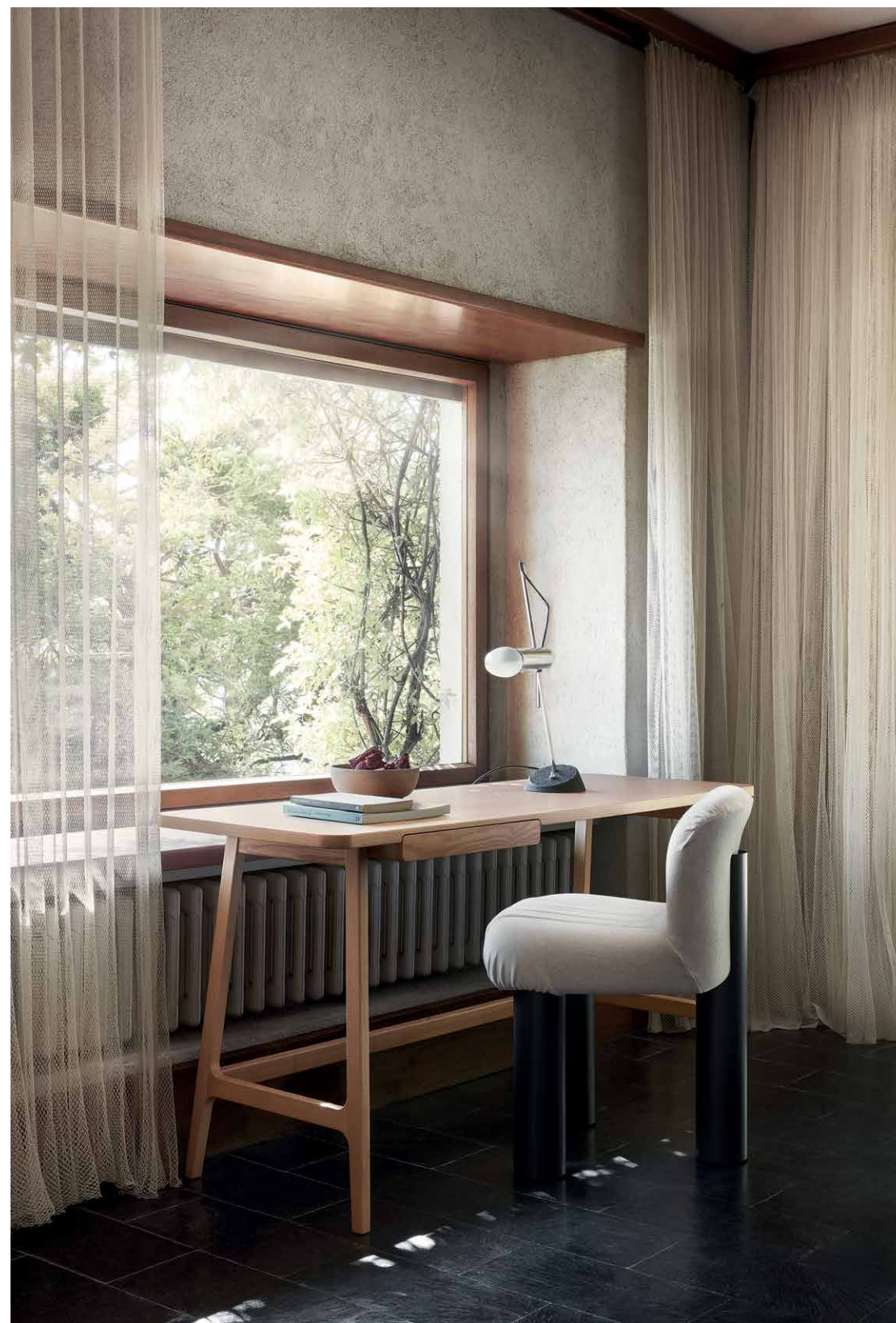

Ben Ben

by Cini Boeri

Ripartendo dal modello Bengodi, disegnato nel 1974, Cini Boeri fu scelta da arflex per creare un sistema di sedute composto da elementi curvilinei, sicuri che sarebbe stato gradito, oggi come allora. Il divano Ben Ben si adatta perfettamente ad ambienti home e contract. Starting again from the model Bengodi, designed in 1974, Cini Boeri was chosen by arflex for creating a seating system composed of curved elements, sure that it would have been appreciated, today as well as then. Ben Ben sofa can be perfectly used both for home and contract environments.

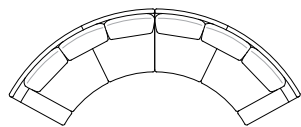

228 / designcollection

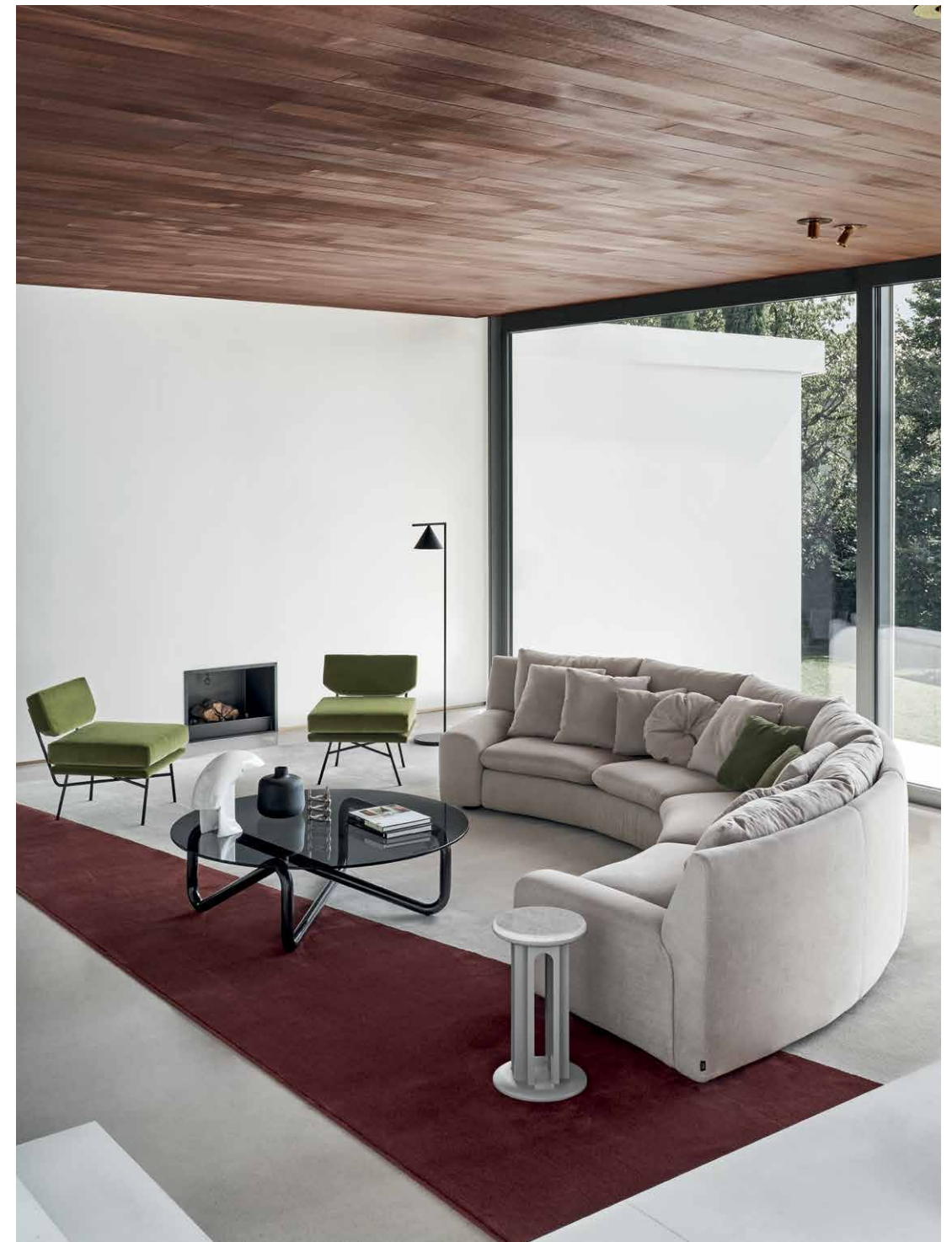

Ben Ben/sofa
composition B 3
Elettra/armchair
Infinity/small table
Arcolor/small table

229 / designcollection



Ben Ben/sofa
composition B 3
Elettra/armchair
Infinity/small table
Capilano/small table

Algon

by Luca Nichetto

Algon è stato sviluppato, fondendo la semplicità scandinava con una tappezzeria trapuntata a motivi geometrici. Disponibile con schienale basso, che ha una rigorosa formalità, e con schienale alto, che lascia un senso di privacy, perfetto per conversazioni silenziose a tarda notte o un momento solitario di tregua. Algon was developed, melding Scandinavian simplicity with a patterned quilted upholstery. Available with low backrest, that has a strict formality, and with high backrest, that allows a sense of privacy, perfect for hushed late-night conversations or a solitary moment of respite.

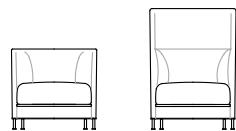

232/designcollection

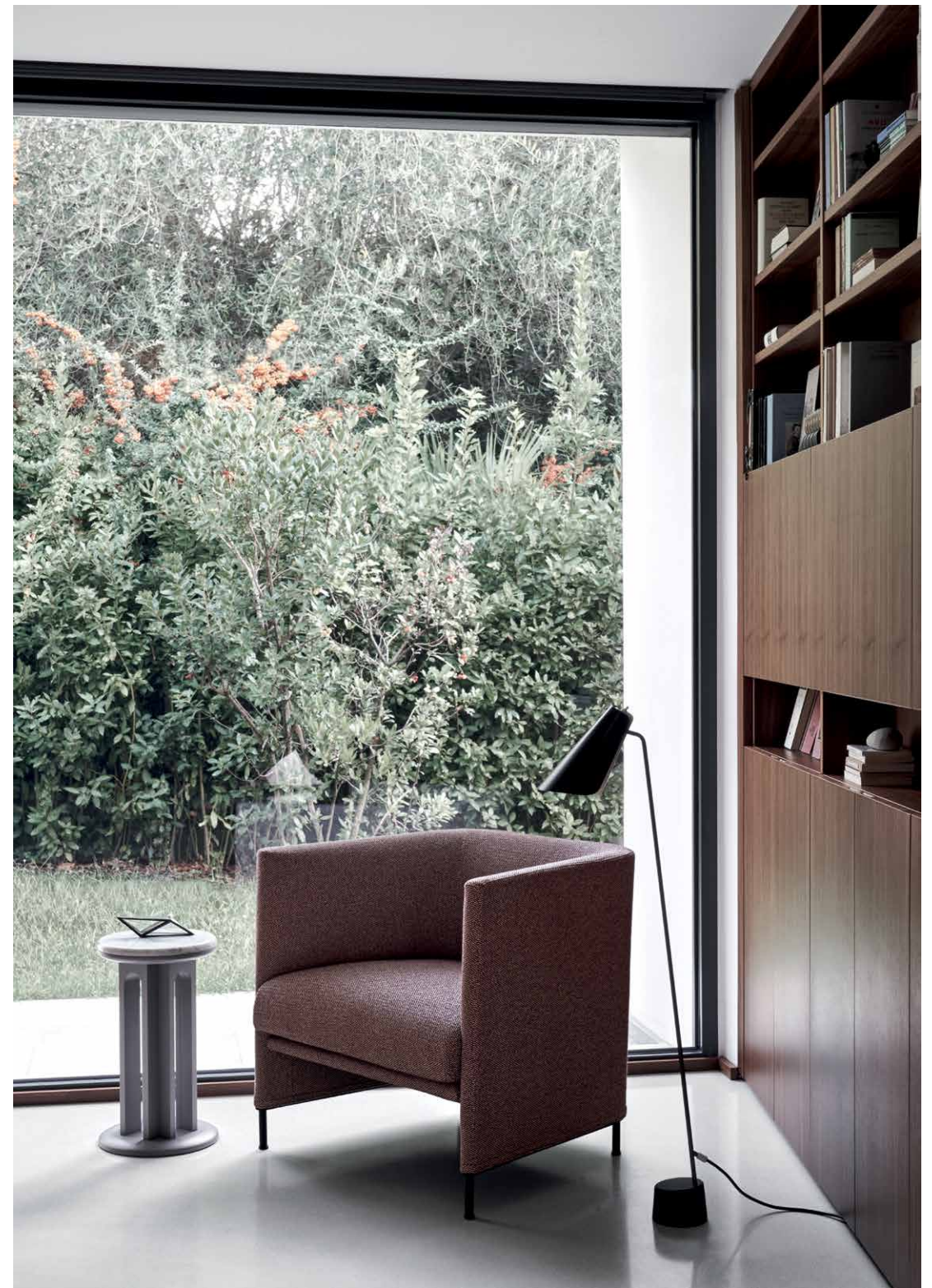

Algon/armchair
Arcolor/small table

233/designcollection

Algon/armchair

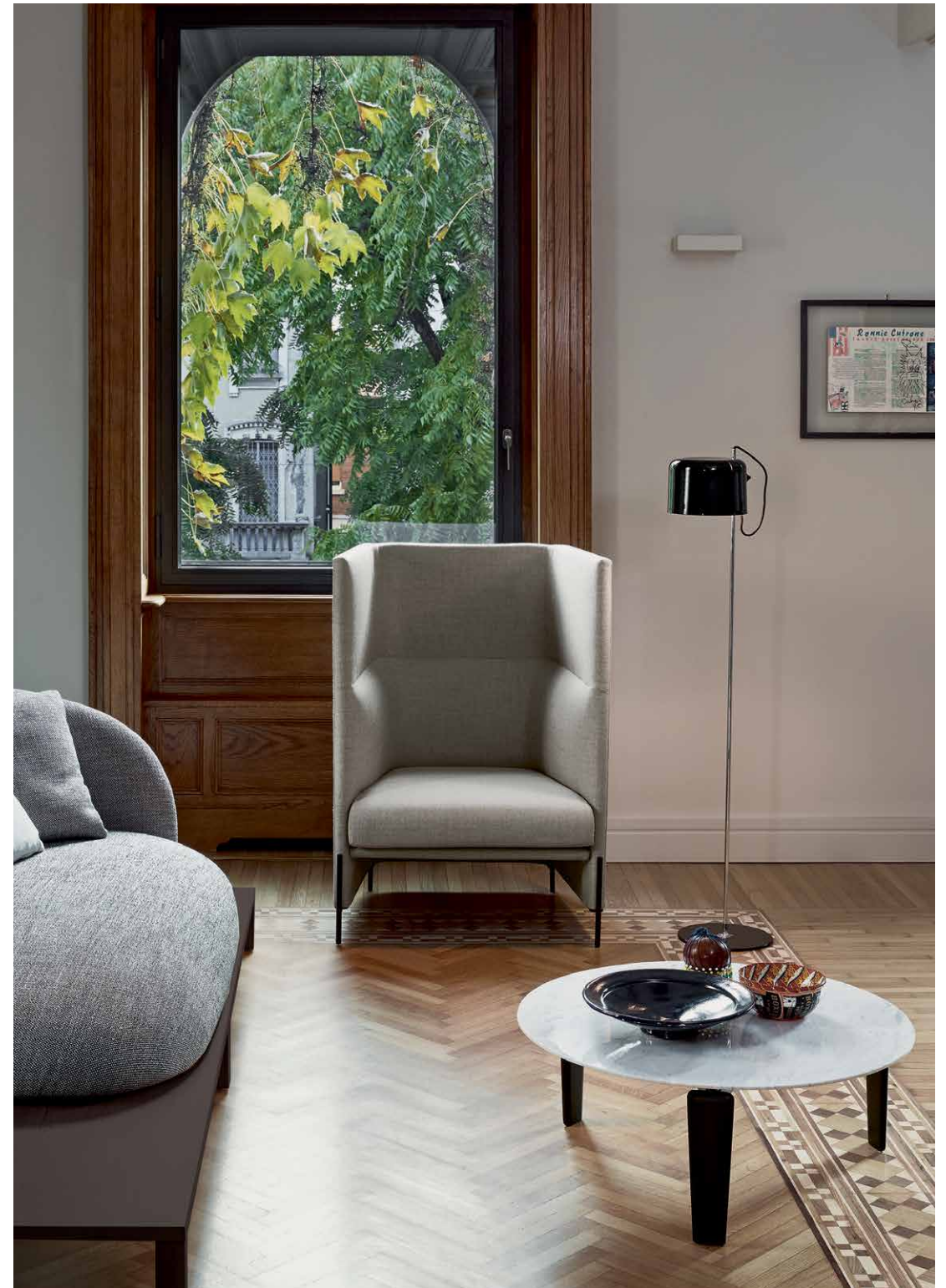

Algon/armchair
Bonsai/sofa
Tablett/small table

Hollywood

by Claesson Koivisto Rune

Nel 2012 Claesson Koivisto Rune disegnano Hollywood, un divano lineare e componibile, caratterizzato da un'estetica leggera e ben proporzionata, con un accento dal sapore scandinavo, che lo rende accogliente in ambienti living e hospitality. In 2012, Claesson Koivisto Rune designed Hollywood, a linear and modular sofa, characterised by a light and well-proportioned aesthetic, with a Scandinavian flavour accent, which makes it welcoming in living and hospitality environments.

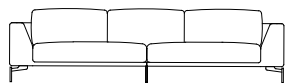



Hollywood/sofa
Hollywood/pouf
Fiorenza/armchair
Cradle/small table



Bonsai

by Claesson Koivisto Rune

La collezione di sedute Bonsai si ispira alle riflessioni sull'estetica e sulla cultura giapponese. I sedili sono caratterizzati da linee morbide e curve. Queste forme invitanti e amichevoli ricordano i cespugli e gli arbusti dei giardini di tutto il Giappone, che sono stati coltivati e tagliati per creare forme belle, morbide, "organiche", simili a nuvole. Bonsai seating collection is inspired by reflections upon Japanese aesthetics and culture. The seats are characterised by soft, curved forms. These inviting, friendly shapes are reminiscent of the bushes and shrubs, found in gardens all over Japan, that have been cultivated and trimmed in order to create beautiful, soft, 'organic', cloud-like shapes.

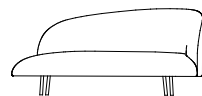

242/designcollection

Bonsai/sofa
Ciclope/mirror
Doge/pouf
Arcolor/small table

243/designcollection



Bonsai/sofa

244/designcollection



Bonsai/sofa
Match/small table

245/designcollection

Tokio

by Claesson Koivisto Rune

La collezione si può raggruppare in una possibilità pressoché infinita di combinazioni: free-standing, in un grande ambiente come isola di sedute oppure anche nella configurazione più tradizionale del divano. The collection can be grouped in an almost endless possibility of combinations: free-standing, in a large room as a seating island, but also grouped in a more traditional sofa configuration.

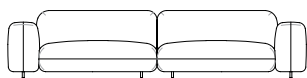

246/designcollection

Tokio/sofa
composition T 09
Island/small table

247/designcollection



Tokio/sofa
composition T 10
Leafo/armchair
Goya/small table
Arcolor/small table
Island/small table

Tokio/sofa
composition T 13



Tokio/module with shelf

Tokio/sofa
composition T 14



Tokio/module with shelf

Tokio/sofa
composition T 15



Tokio/module with shelf



Tokio/small table
with drawer

Tokio/sofa
composition





Tokio/small table



Tokio/small table



Tokio/service



Tokio/service

Tokio/sofa
composition



Tokio/sofa
composition





Tokio/sofa
composition T 08
Goya/small table

254/designcollection

Delfino/armchair
capsule collection
Bloody 001
category T5

255/designcollection



Tokio/sofa
composition T 01
Cross/armchair
Sigmund/small table
Goya/service

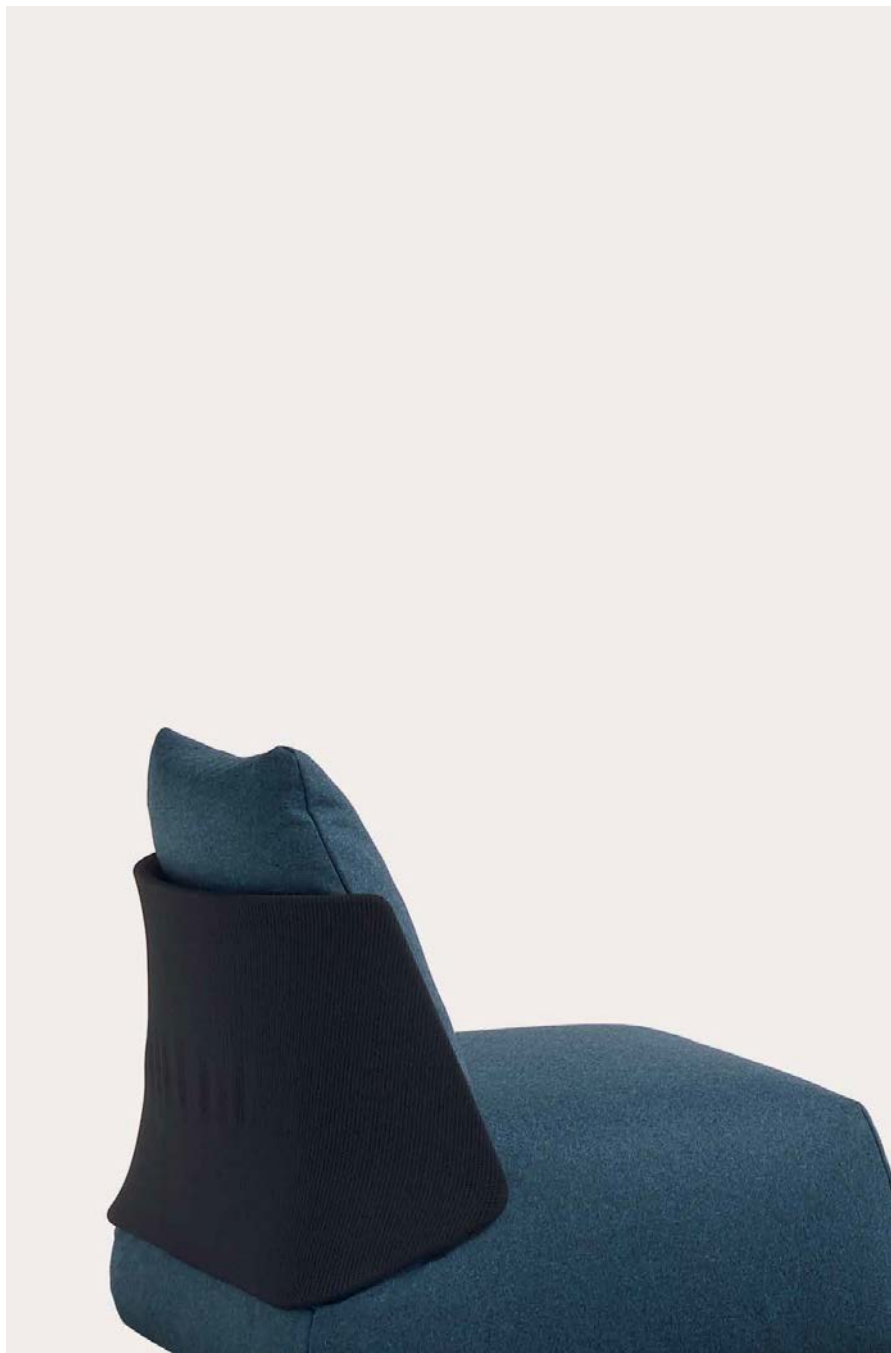

Butterfly/armchair
capsule collection
Bloody 002
category T5
Tokio/sofa
Goya/service



Rendez-Vous

by Mauro Lipparini

Serenità, semplicità, modularità sono alcune delle parole chiave di Rendez-Vous. Il suo generale rigore formale è accompagnato dall'esuberanza della morbidezza interiore, come il tentativo di abbracciare e trattenere il corpo e il piacere del comfort.

Serenity, simplicity, modularity are some of the key words of Rendez-Vous. Its overall formal rigor is accompanied by the exuberance of the inner softness, as trying to hug and hold the body and the pleasure of comfort.

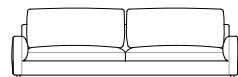

260/designcollection



Rendez-Vous/sofa
Tablet/small table
Giulietta/armchair

261/designcollection



Rendez-Vous/sofa
composition R 15
Hall/armchair
Doge/pouf
Tablet/small table

Rendez-Vous/sofa
composition R 13
Capilano/small table
Doge/pouf



Rendez-Vous/sofa
composition R 13
Tablet/small table
Capilano/small table
Diva/screen



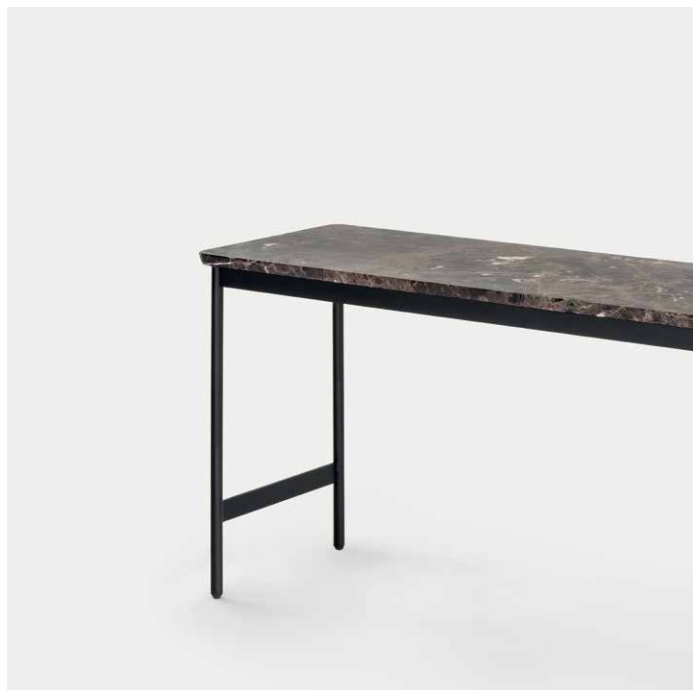

266/designcollection



Capilano/small table
Lee/sofa

267/designcollection

Rubycon

by Claesson Koivisto Rune

Minima forma, massima varietà espressiva. Il concept Rubycon permette di creare contenitori unici e autoportanti, attraverso la personalizzazione, dando anche la possibilità di avere pezzi decorativi e laccati, in tinta o in contrasto, a seconda della posizione in cui vengono collocati. Il concetto di Rubycon utilizza la ripetizione di un singolo "cubo" di archiviazione per creare una colonna orizzontale in cinque diverse lunghezze. Minimal form, maximum variety of expression. Rubycon concept allows the creation of unique, free-standing cabinets, through customisation, giving also the possibility to have decorative and lacquered pieces, in matching or contrasting colours, depending where they are placed. Rubycon concept uses the repetition of a single storage 'cube' to create a horizontal column in five different lengths.





270/*designcollection*

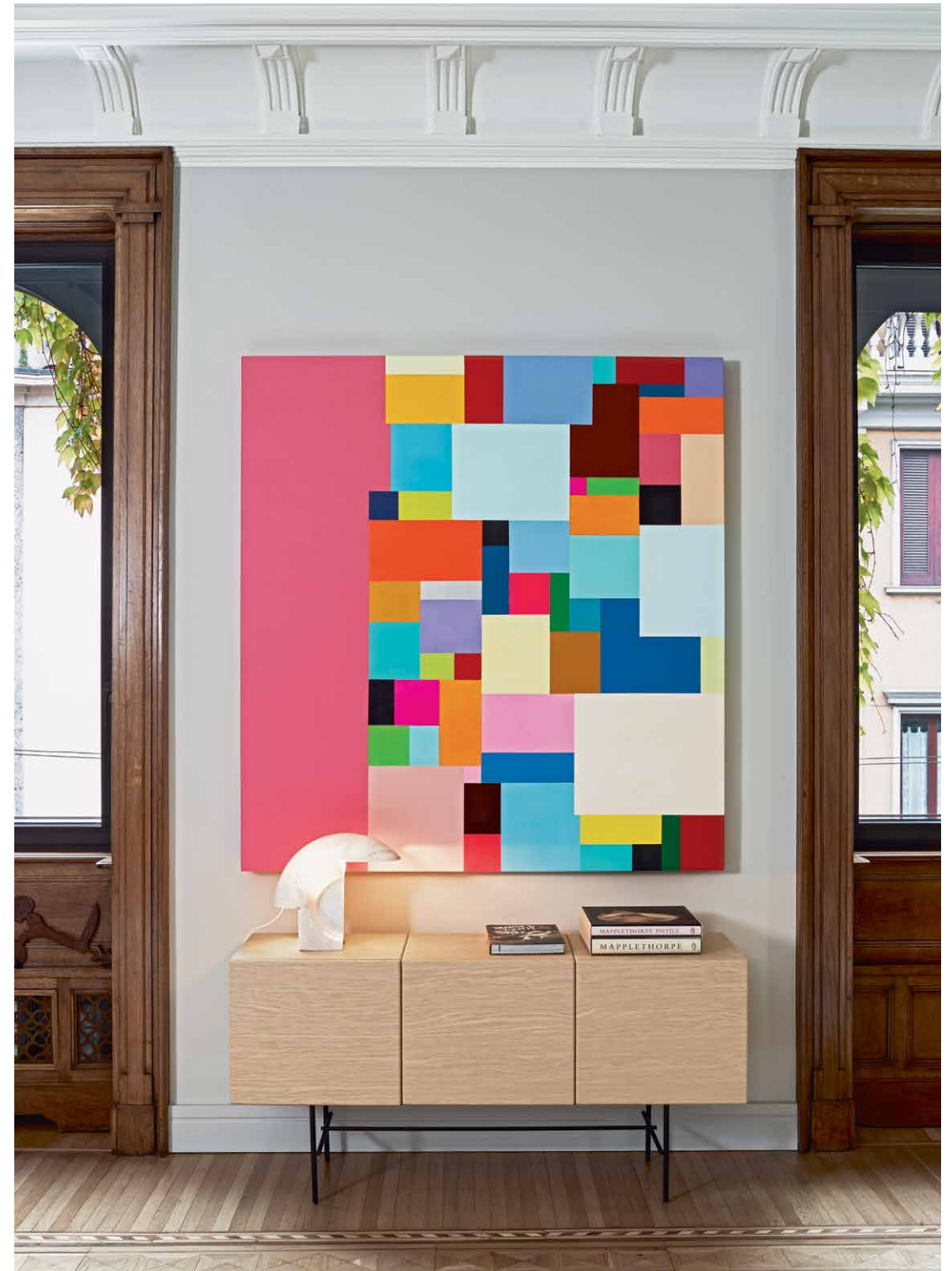

Rubycon/sideboard

271/*designcollection*

Claudine

by Claesson Koivisto Rune

*Una tipologia classica servita su un dolce vassoio, il divano ha una configurazione flessibile - alto, basso, piccolo, grande, a due posti, tre posti, pouf - sempre sospeso su un bordo rovesciato, che ricorda il colletto dell'abito, noto in francese come "col Claudine".
A classic typology served on a tender tray, the sofa is flexible in configuration - high, low, small, big, two-seater, three-seater, pouf - always floating on an upturned edge, reminiscent of the dress collar known in French as "col Claudine".*

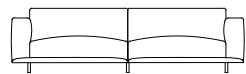

272/designcollection

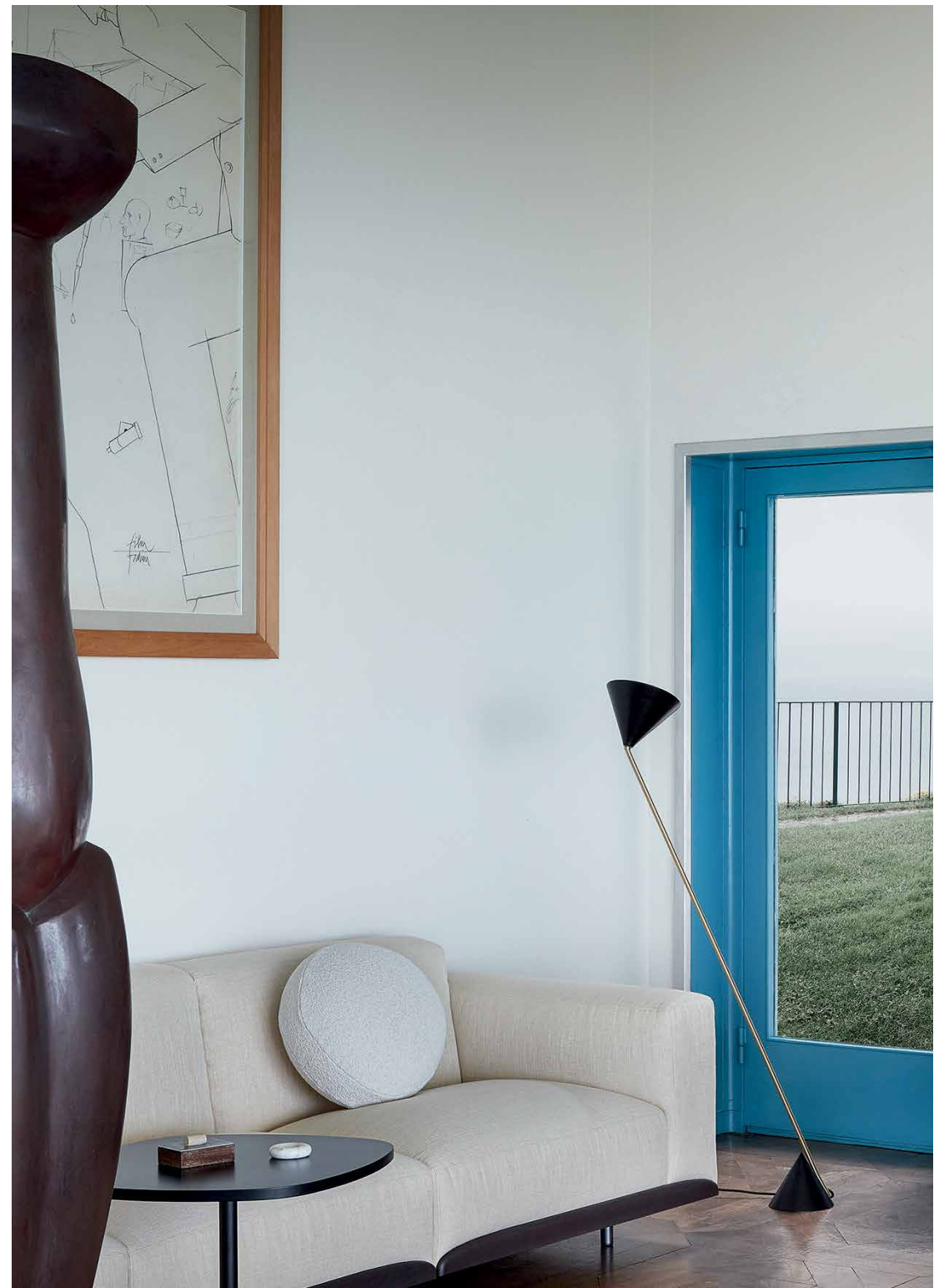

Claudine/sofa
Island/small table

273/designcollection







Serena/armchair
Doge/pouf



Soft Beat

by Claesson Koivisto Rune

Onde lente, dolci colline, pulsazioni rilassanti: gentile, morbido, iconico – Soft Beat.

Slow waves, rolling hills, soothing pulse: kind, soft, iconic – Soft Beat.

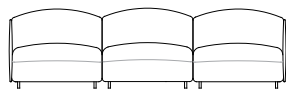

280/designcollection



Soft Beat/sofa
composition SB 03
Arcolor/small table

281/designcollection



Soft Beat/sofa
Match/small table
Elettra/armchair

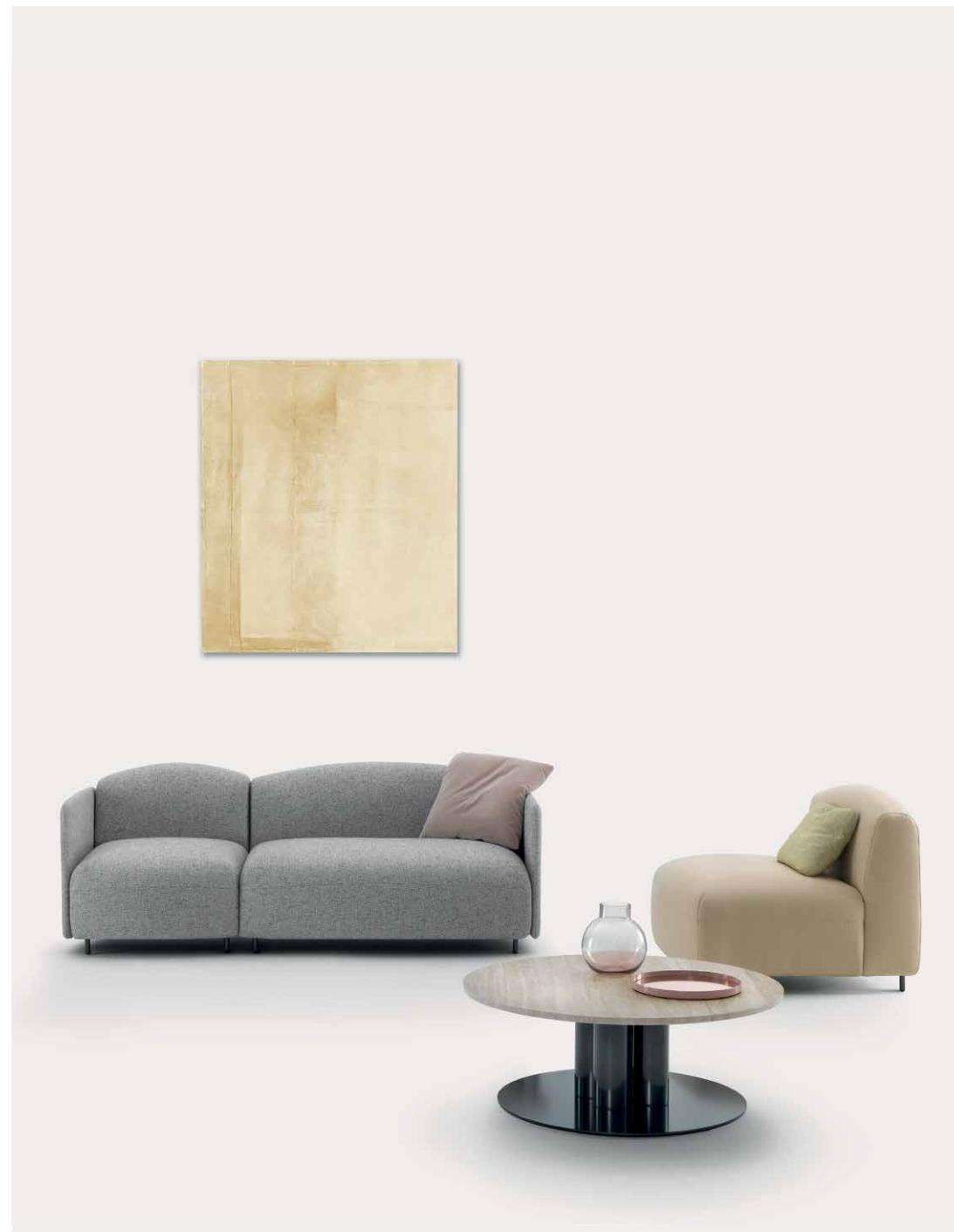

Soft Beat/sofa
composition SB 07
Soft Beat/armchair
Goya/small table

K2

by Carlo Colombo

Un sistema di sedute di grande formato e di particolare comfort. Ispirato alle alte vette, ma caratterizzato da una grande eleganza formale, si adatta con stile ed eleganza a tutti gli spazi.

A seating system of large format and particular comfort. Inspired by the high peaks, but characterised by great formal elegance, it adapts with style and elegance to all spaces.



284/designcollection



K2/sofa
composition K 02
Island/small table

285/designcollection



K2/sofa
composition K 02
Island/small table
Goya/small table
Giulietta/armchair
Delfino/pouf



288/*designcollection*



K2/sofa
composition K 03
Cradle/small table

289/*designcollection*

Giulietta by B.B.P.R.

Il design degli anni 50 nasce in un momento in cui l'Italia voleva il riscatto dopo la guerra. Gli architetti (non ancora chiamati designer) e le aziende hanno creato prodotti per trasmettere speranza e buon umore nelle persone. Lo studio B.B.P.R. ha disegnato la poltrona Giulietta, con tutte le caratteristiche della produzione arflex: studio approfondito della linea e comfort assoluto, senza dimenticare l'eleganza. The 50-years design was born at a time when Italy wanted redemption after the war. The architects (not yet called designer) and the companies created products to inspire hope and good humour to people. B.B.P.R. office designed the armchair Giulietta, with all the characteristics of arflex production: deep study of the line and absolute comfort, without forgetting the elegance.



290/designcollection

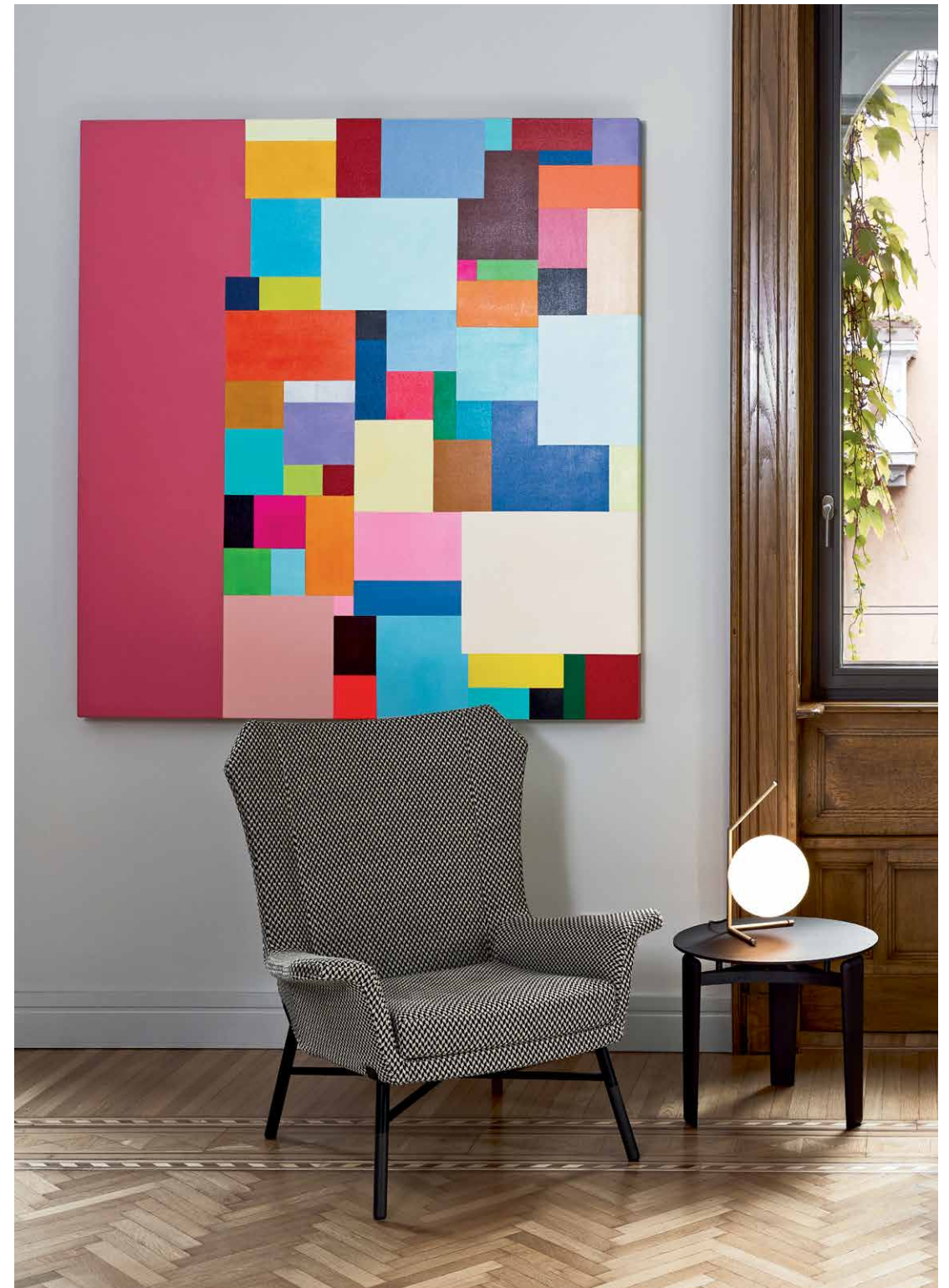

Giulietta/armchair
Tablet/small table

291/designcollection



Giuletta/armchair
Bonsai/small table

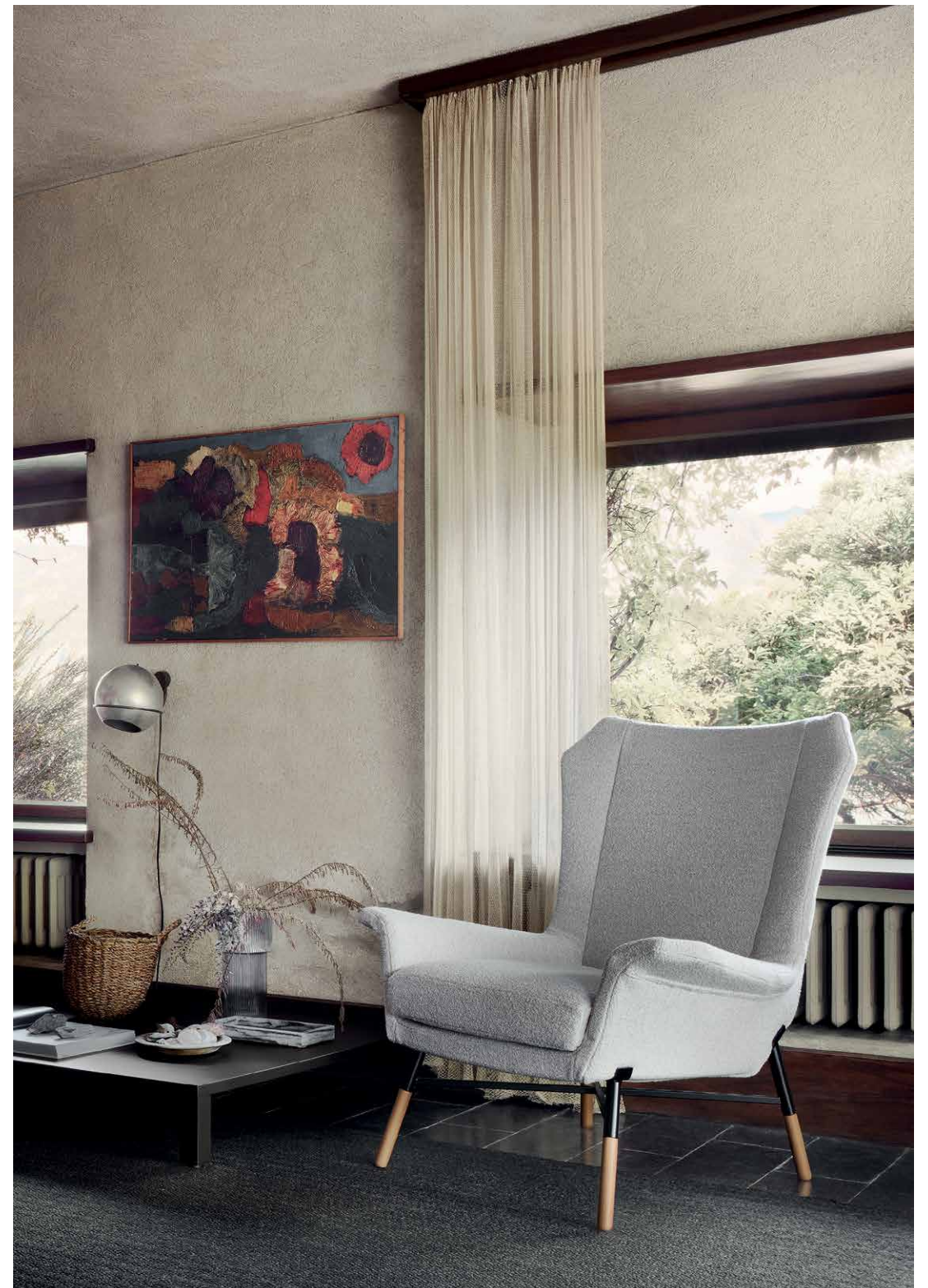

Frame

by Carlo Colombo

Sistema di sedute dalla linea confortevole, la cui struttura può essere arricchita dall'intreccio manuale della pelle bovina, per dare al divano uno scenario elegante. Frame nasce per arredare con gusto e stile gli spazi del living e dell'hospitality.

Seating system with a comfortable line, where its structure can be enriched by the manual woven cowhide, giving to the sofa an elegant scene. Frame was designed to furnish living and hospitality spaces with taste and style.



294/designcollection



Frame/sofa
Penta/pouf

295/designcollection



Frame/sofa
composition F 10
Goya/small table
Sigmund/small table
Match/console



Faubourg/sofa





Katrin/armchair



arflex
collection

technical drawings



9000

Poltrona
Armchair

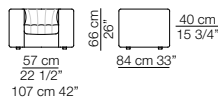

Pouf

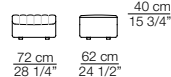

Composizioni
Compositions

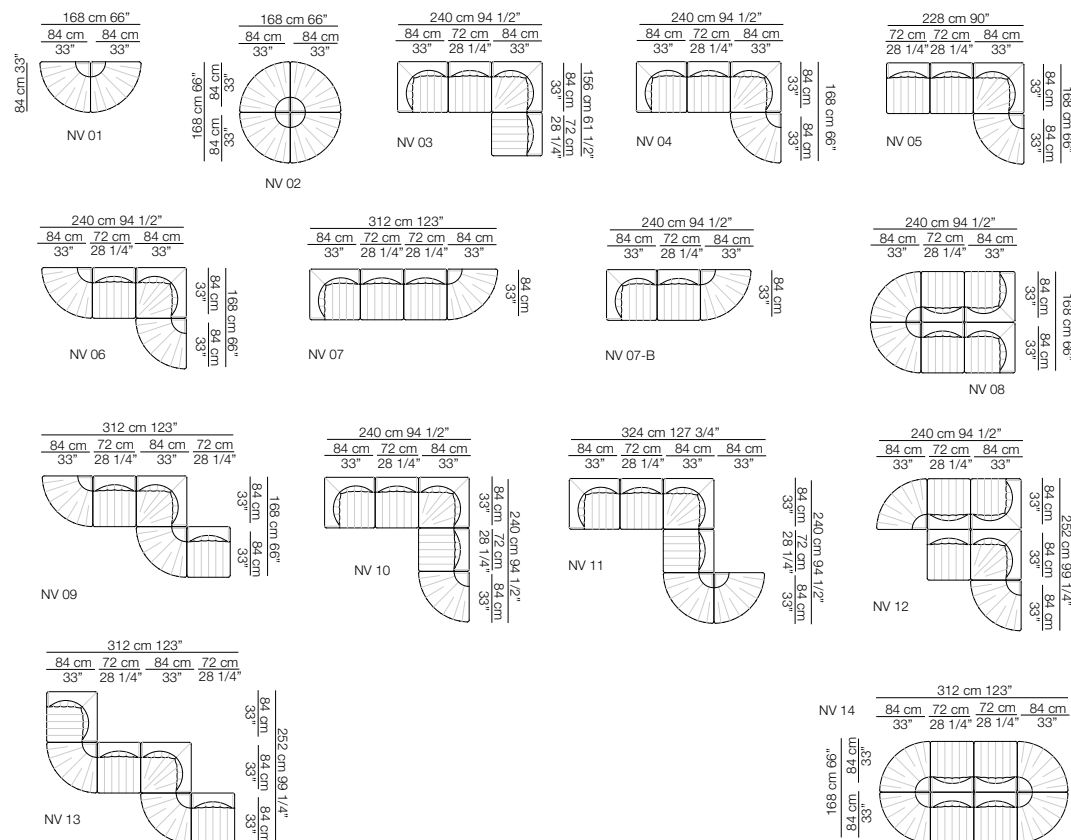

Arcolor

Divani
Sofas

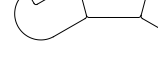
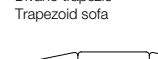
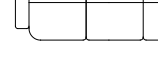
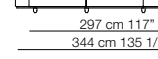
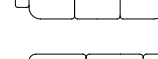
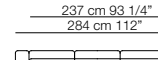
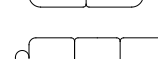
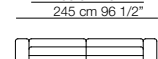
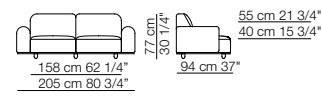

Composizioni
Compositions

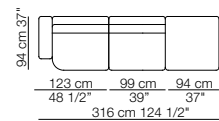

AR 01

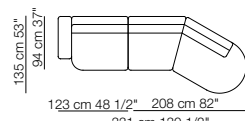

AR 02

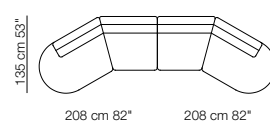

AR 03

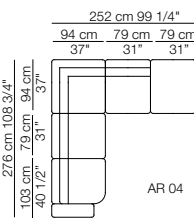

AR 04

Elementi con 1 bracciolo
Units with 1 armrest

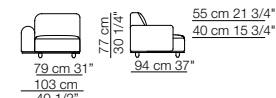

Elementi senza braccioli
Units without armrests

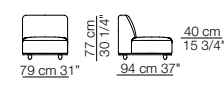

Pouf

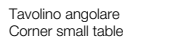
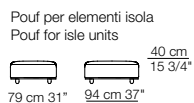
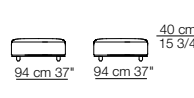

Divani / Sofas

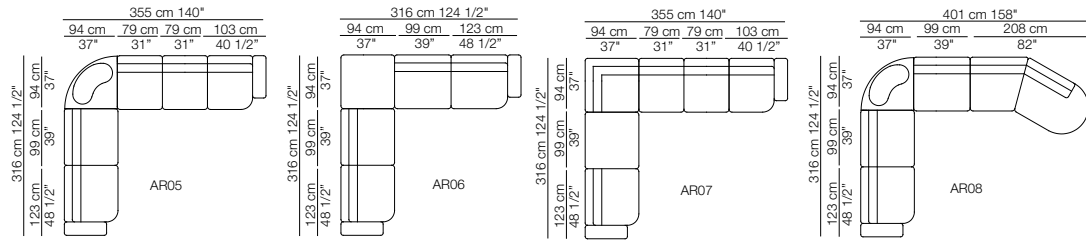

Bel air

Divani
Sofas

Elementi con 1 bracciolo
Units with 1 armrest

Elementi senza braccioli
Units without armrests

Elementi angolo
Corner units

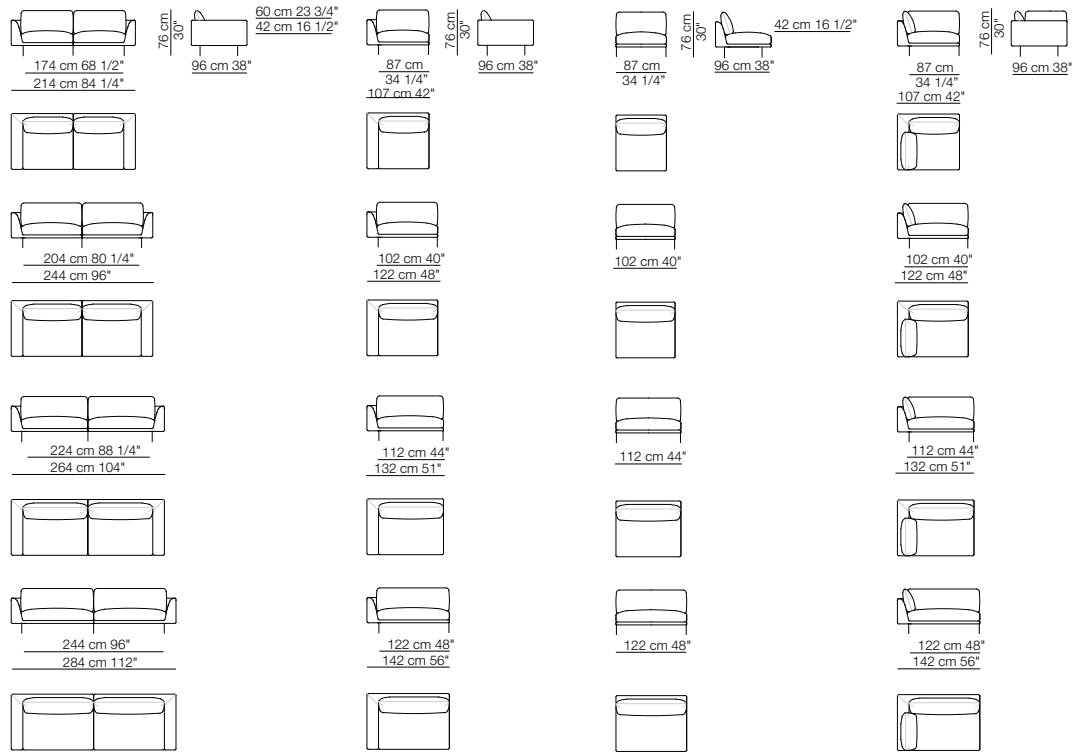

Elemento isola trapezio senza braccioli
Trapezoid isle unit without armrests

Elemento trapezio con 1 bracciolo
Trapezoid unit with 1 armrest

Elemento isola trapezio senza braccioli con piano
Trapezoid isle unit without armrests with top

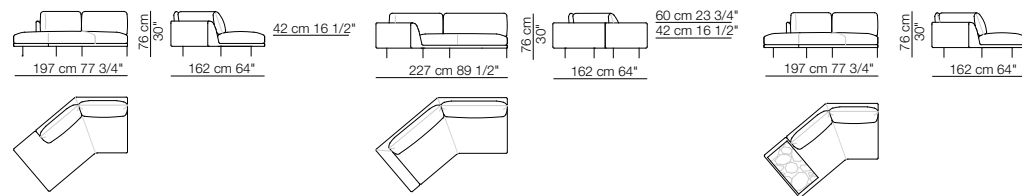

Pouf

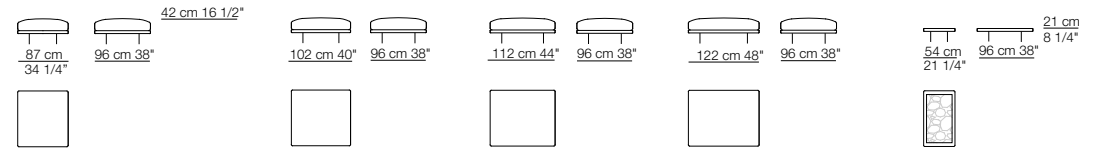

Composizioni
Compositions

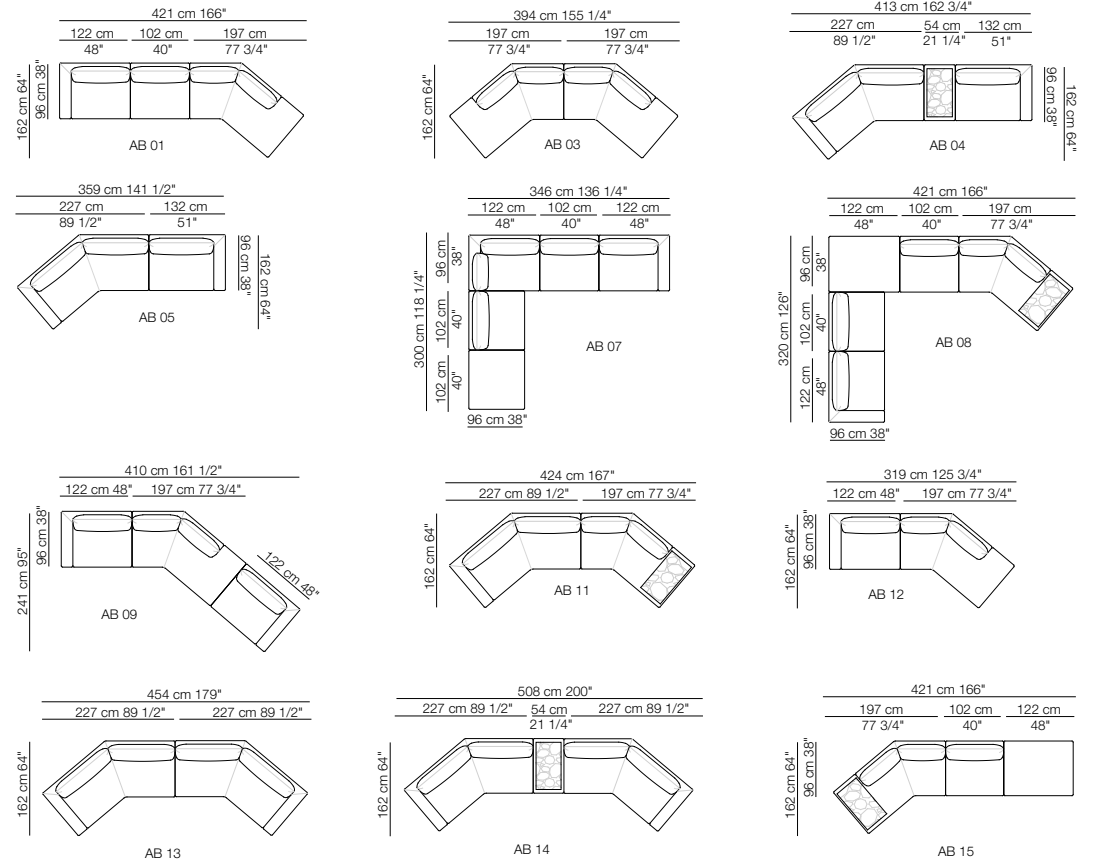

Banah

Dormeuse

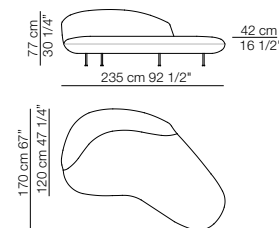

Divani / Sofas



Ben Ben

Divano
Sofa

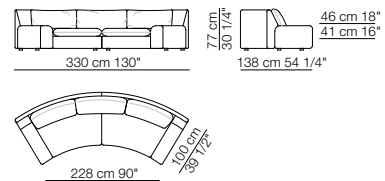

Elementi con 1 bracciolo
Units with 1 armrest

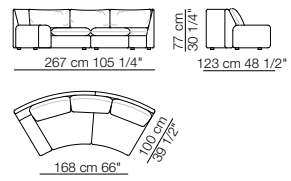

Elemento senza braccioli
Unit without armrests

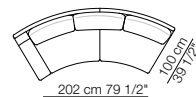
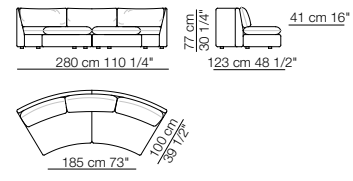

**Composizioni
Compositions**

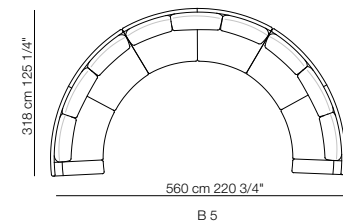
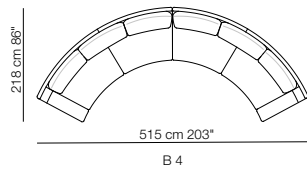
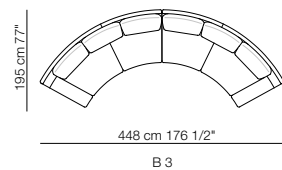

Bonsai

Divano con base in metallo
Sofa with metal base

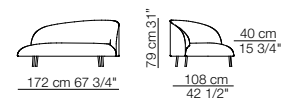

Divano con base in legno
Sofa with wooden base

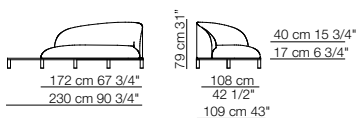

Tavolino
Small table

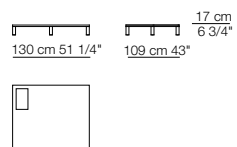

Divano con base in metallo e gonnella
Sofa with metal base and skirt

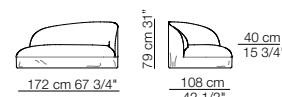

Claudine M

Divani
Sofas

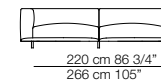
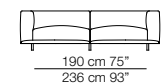
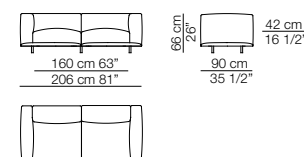

Elementi con 1 bracciolo
Units with 1 armrest

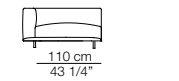
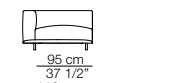
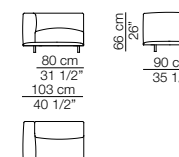

Elementi senza braccioli
Units without armrests

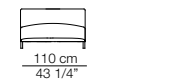
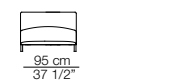
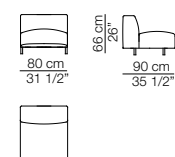

Chaise longue con 1 bracciolo
Chaise longue with 1 armrest

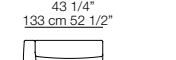
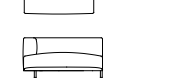
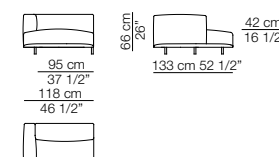

Elemento angolo
Corner unit

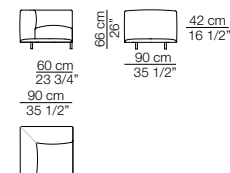

Pouf

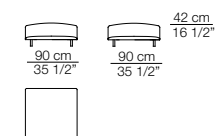



Claudine L

Divani Sofas

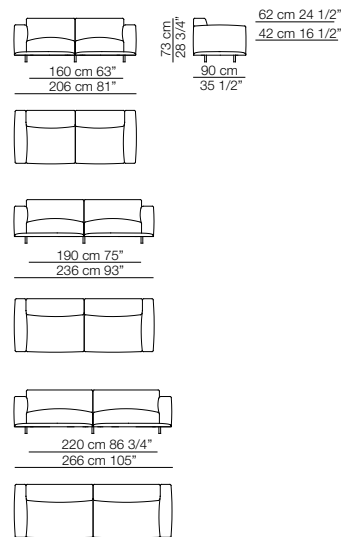

Elementi con 1 bracciolo
Units with 1 armrest

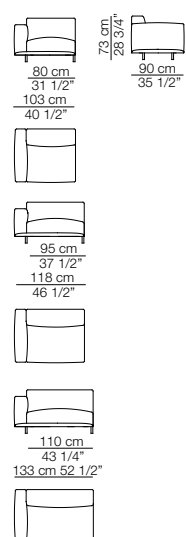

Elementi senza braccioli
Units without armrests

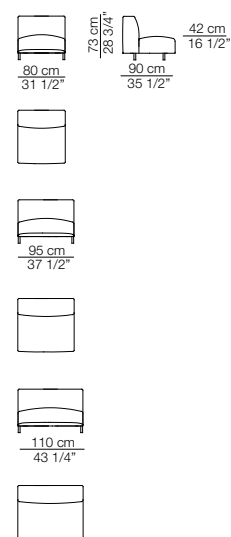

Chaise longue con 1 bracciolo
Chaise longue with 1 armrest

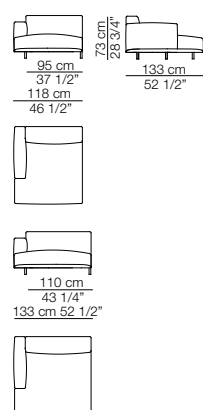

Elemento angolo
Corner unit

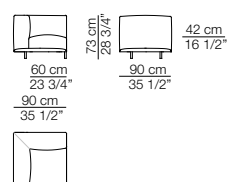

Pouf

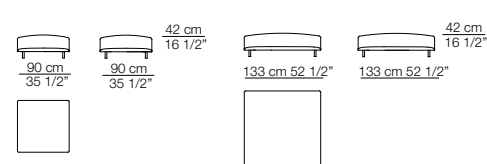

Claudine M-L

Composizioni
Compositions

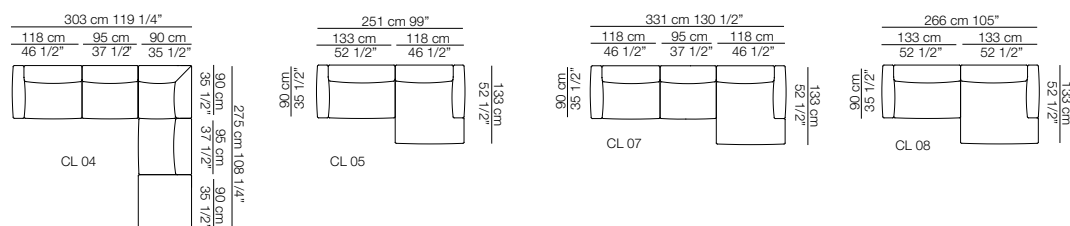

Cousy

Poltrona
Armchair

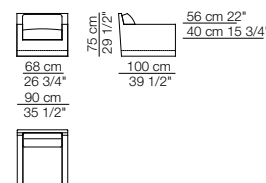

Chaise longue con 2 braccioli
Chaise longue with 2 armrests

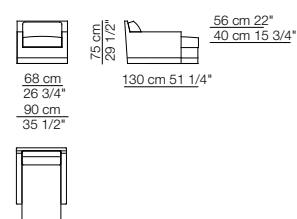

Pouf

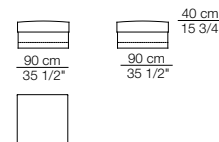

Cradle

Divano
Sofa

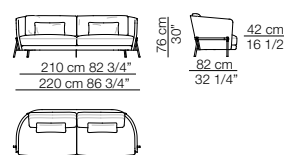

Service

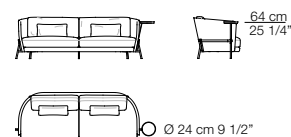

Faubourg

Divani
Sofas

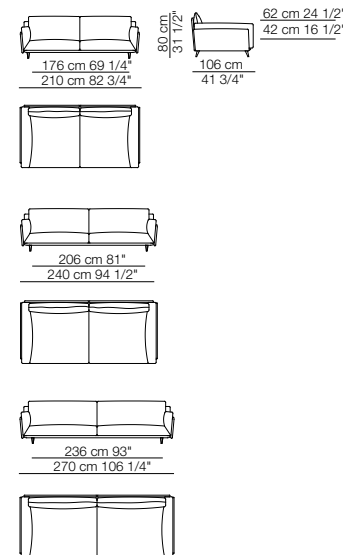

Cuscini Faubourg
Faubourg cushions

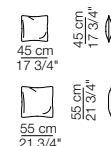

Deep Cradle

Divano
Sofa

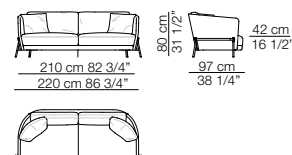



Frame

Divani
Sofas

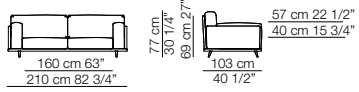

Versione in cuoio
Cow hide version

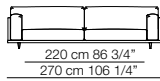
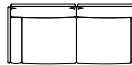
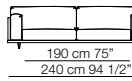
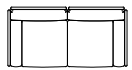

Elementi angolo
Corner units

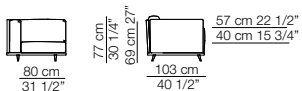

Versione in cuoio
Cow hide version

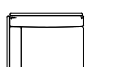
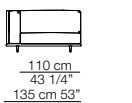
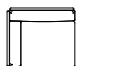
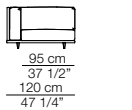

Elementi con 1 bracciolo
Units with 1 armrest

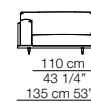
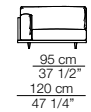
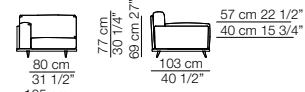

Chaise longue con 1 bracciolo
Chaise longue with 1 armrest

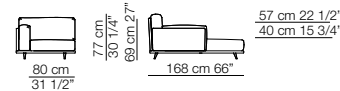

Versione in cuoio
Cow hide version

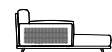
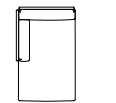

Elementi senza braccioli
Units without armrests

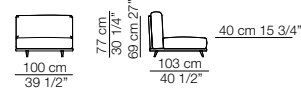

Pouf

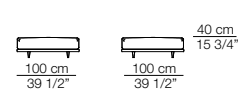

**Composizioni
Compositions**

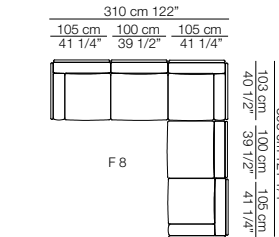
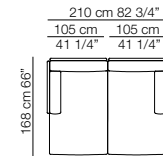
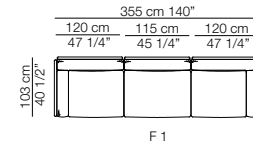

Hall
Divano
Sofa

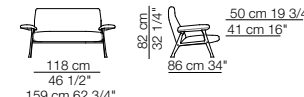

Pecorelle
Divano
Sofa

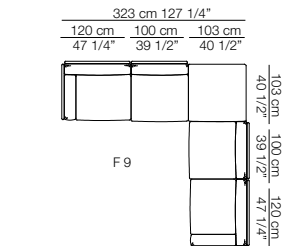
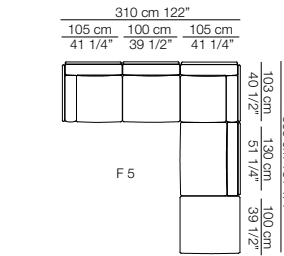
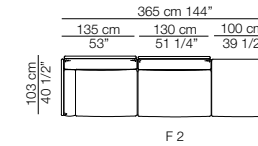
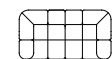
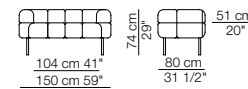

Hug love seat
Divano con schienale basso
Sofa with low backrest

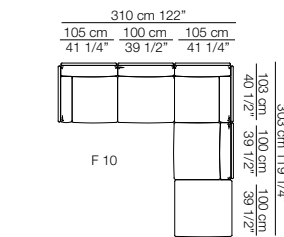
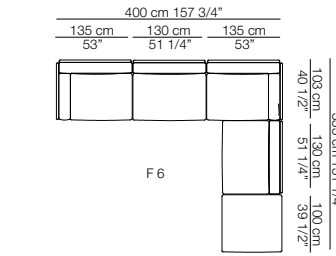
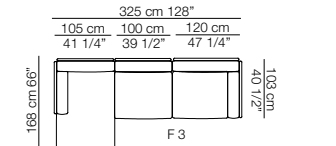
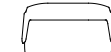
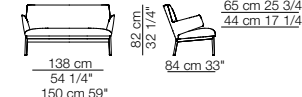

Hug love seat
Divano con schienale alto
Sofa with high backrest

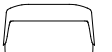
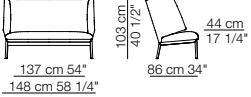



Hollywood

Divani
Sofas

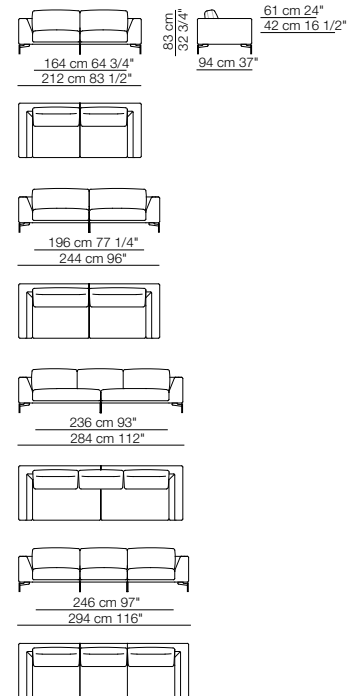

Elementi con 1 bracciolo
Units with 1 armrest

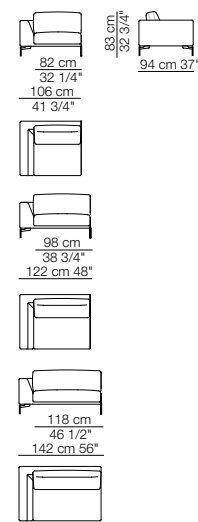

Elementi senza braccioli
Units without armrests

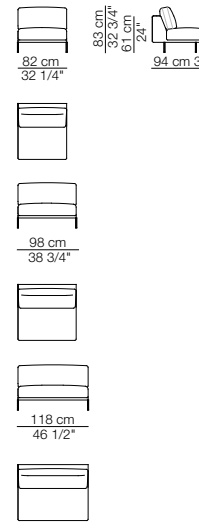

Elementi isola senza braccioli
Isle units without armrests

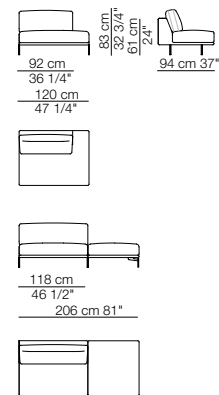

Elementi isola con angolo
Isle units with corner unit

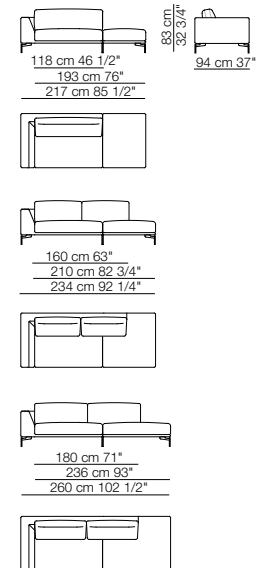

Elementi con 1 bracciolo P.120
Units with 1 armrest D.120

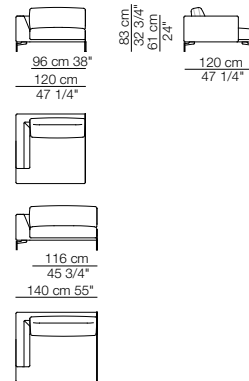

Chaise longue con 1 bracciolo
Chaise longue with 1 armrest

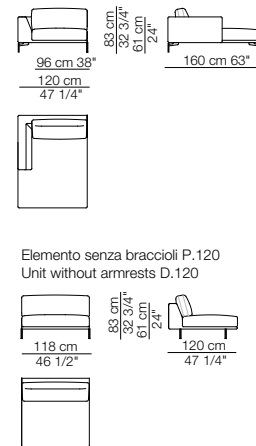

Elemento senza braccioli P.120
Unit without armrests D.120

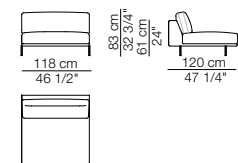

Pouf

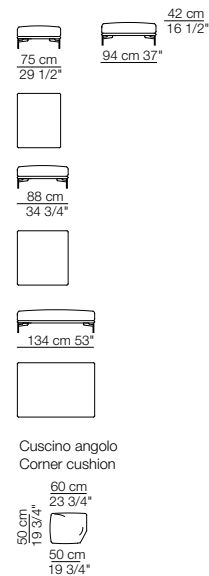

**Composizioni
Compositions**

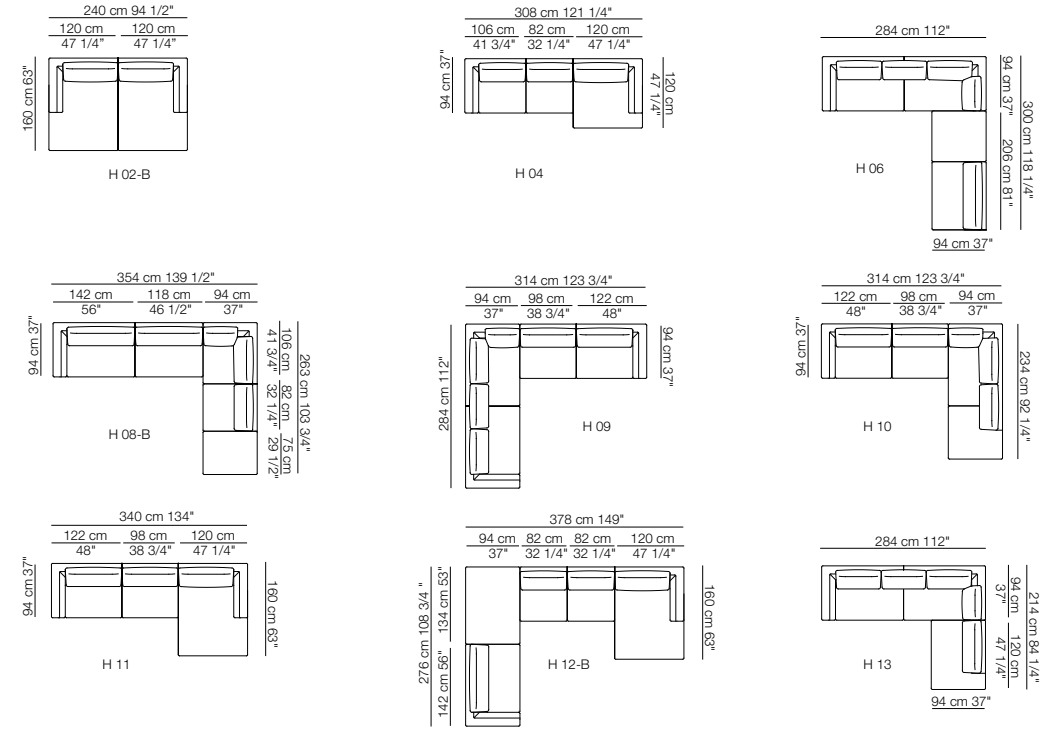

K2

Divani
Sofas

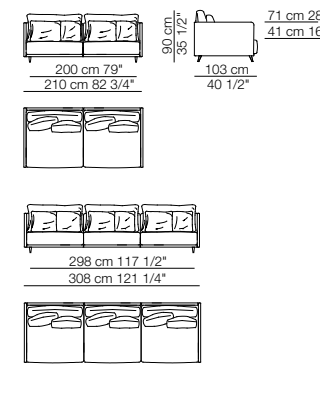

Elemento con 1 bracciolo
Unit with 1 armrest

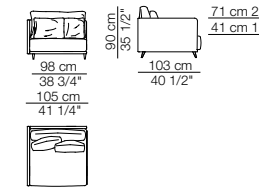

Elemento senza braccioli
Unit without armrests

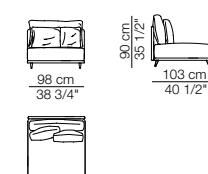

Elemento angolo
Corner unit

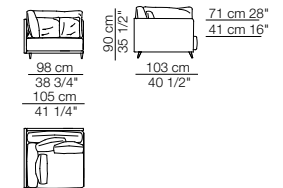

Pouf

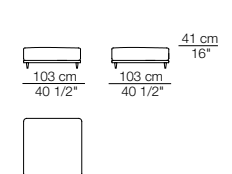

Cuscini
Cushions

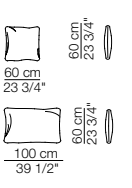

Composizioni
Compositions

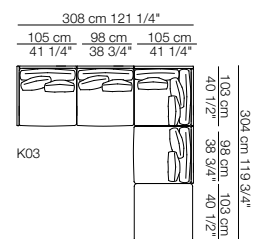
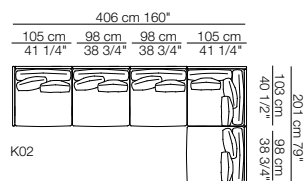
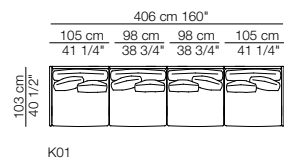

Lee
Divani
Sofas

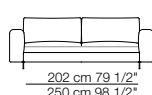
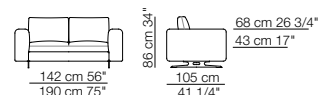

Elementi con 1 bracciolo
Units with 1 armrest

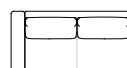
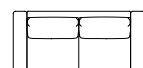
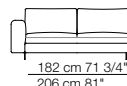
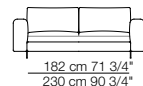
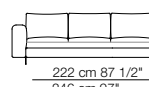
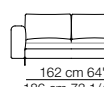
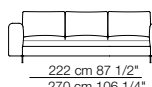
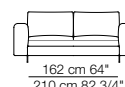
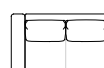
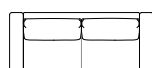
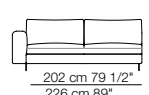
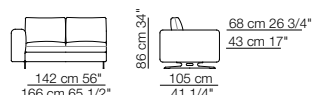

Elementi senza braccioli
Units without armrests

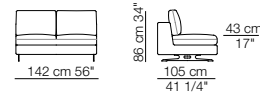

Elementi angolo con 1 bracciolo
Corner units with 1 armrest

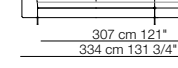
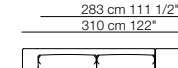
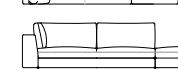
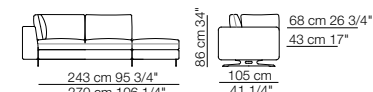
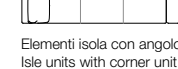
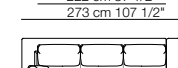
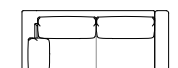
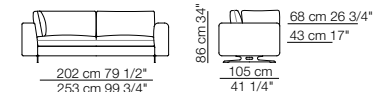

Chaise longue con 1 bracciolo
Chaise longue with 1 armrest

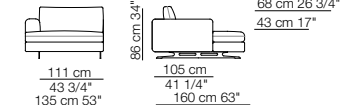

Cuscino schienale con movimento
Backrest cushion with motion

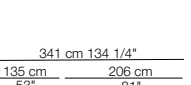
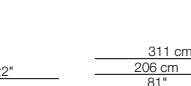
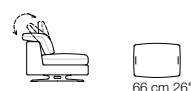

Composizioni
Compositions

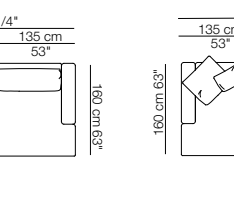
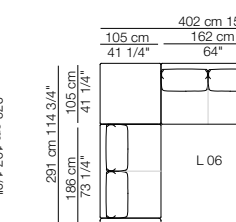
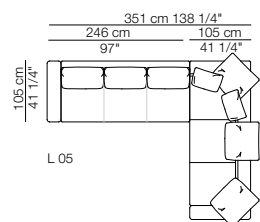
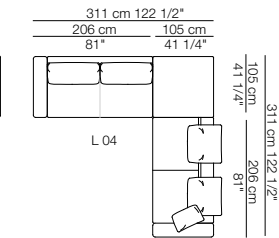
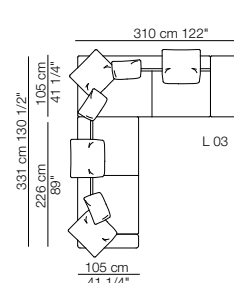
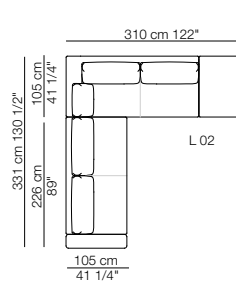
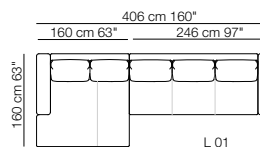



Leenus

Divani
Sofas

Elementi con 1 bracciolo
Units with 1 armrest

Elementi senza braccioli
Units without armrests

Elementi isola con angolo
Isle units with corner

Chaise longue con 1 bracciolo
Chaise longue with 1 armrest

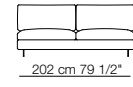
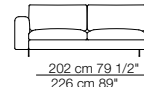
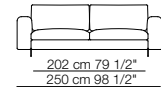
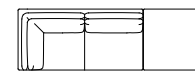
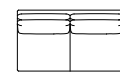
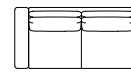
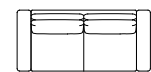
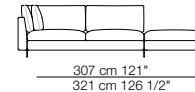
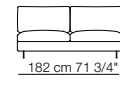
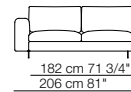
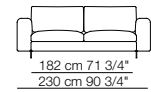
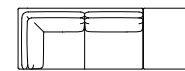
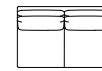
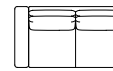
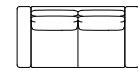
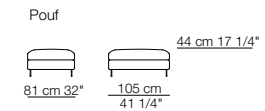
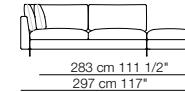
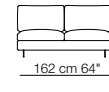
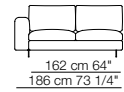
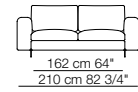
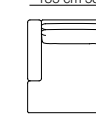
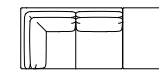
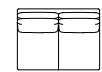
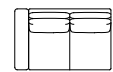
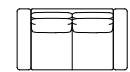
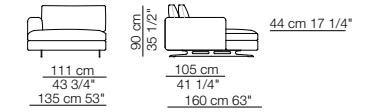
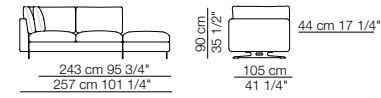
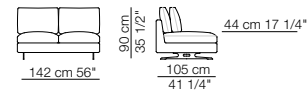
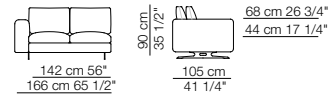
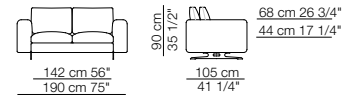

**Composizioni
Compositions**

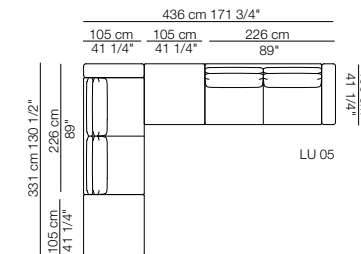
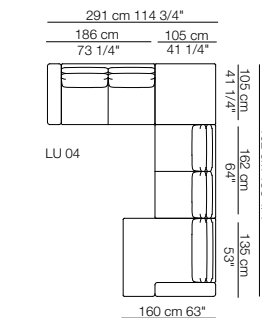
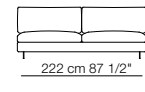
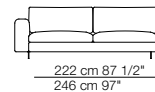
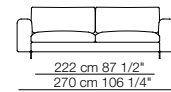
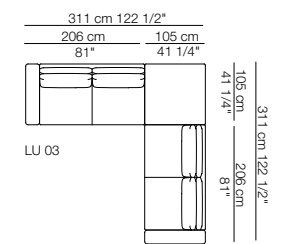
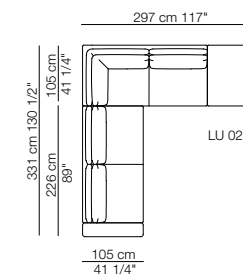
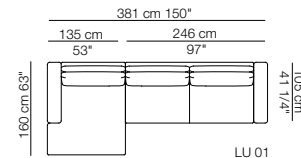

Divani / Sofas

Sofa with low standard armrests - version "L"



Sofa with high armrests - version "H"



Low land

Divani Sofas

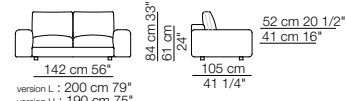

Elementi con 1 bracciolo Units with 1 armrest

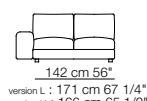

Elementi senza braccioli Units without armrests

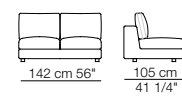

Elementi angolo con 1 bracciolo Corner units with 1 armrest

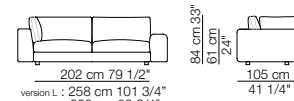

Marechiaro

Poltrone con braccioli bassi Armchairs with low armrests

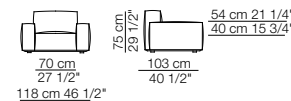

Divani Sofas

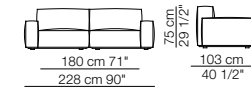

Elementi con 1 bracciolo Units with 1 armrest

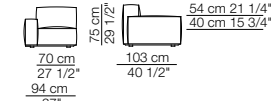

Elementi con 1 bracciolo alto Units with 1 high armrest

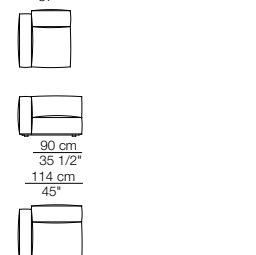
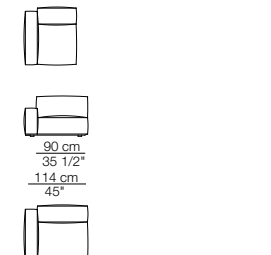
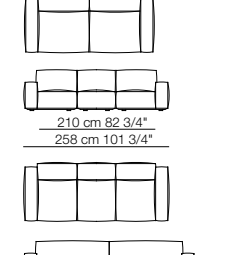
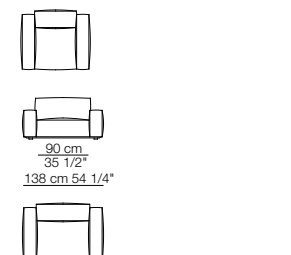
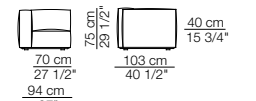

Poltrona con braccioli alti Armchair with high armrests

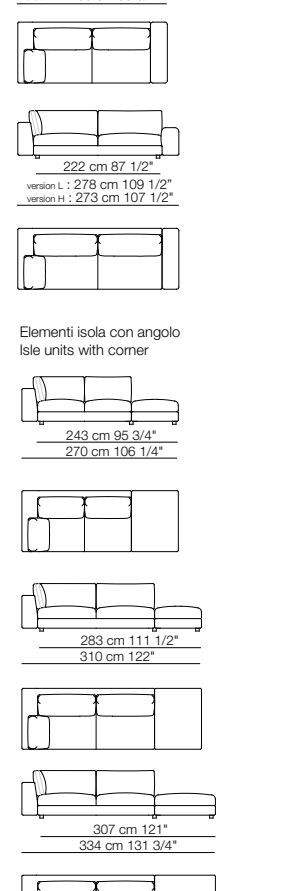
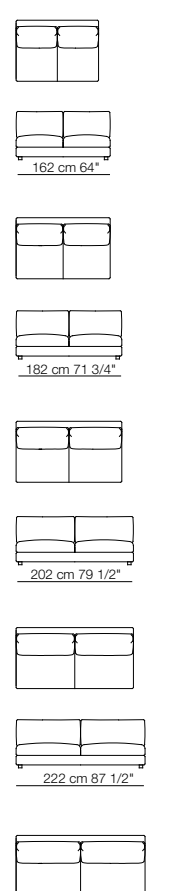
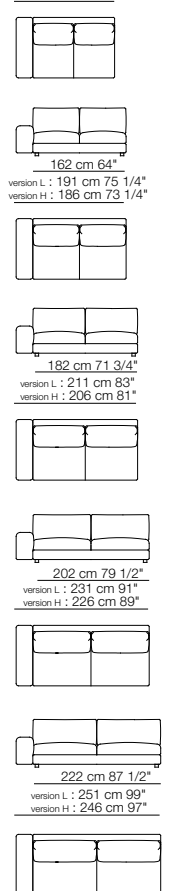
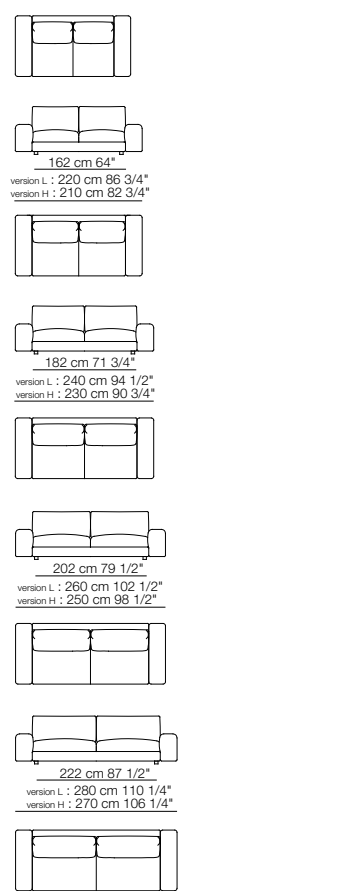
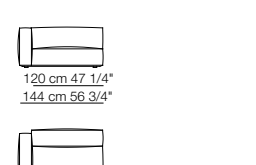
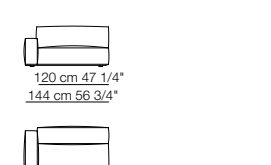
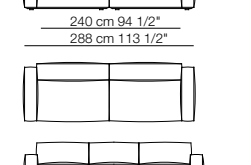
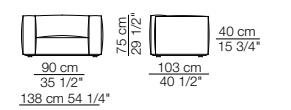

Elementi senza braccioli Units without armrests

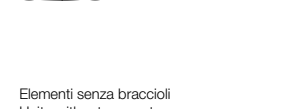

Elementi senza braccioli con schienale basso Units without armrests with low backrest

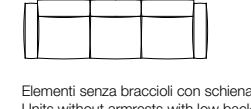

Elementi angolo Corner units



Elementi isola Isle units

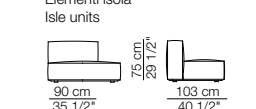

Pouf

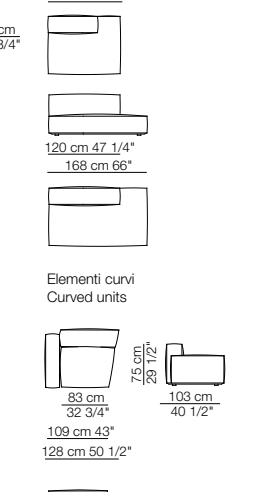
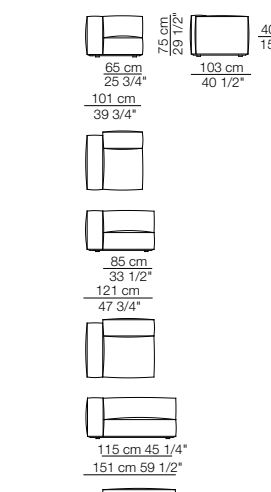
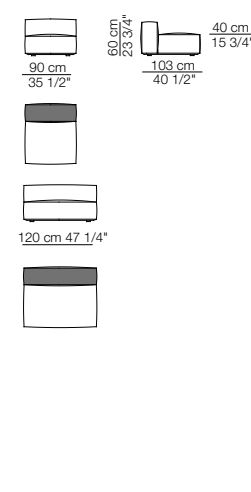
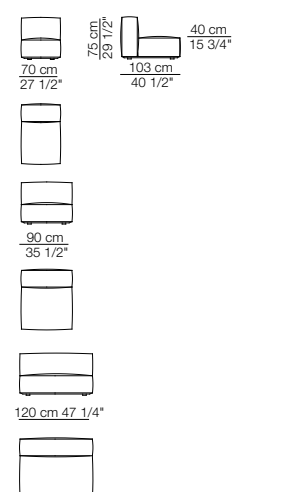
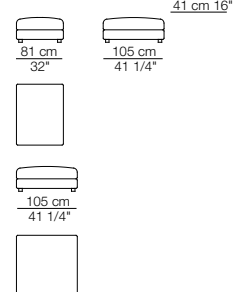



Elementi con 1 bracciolo P.120
Units with 1 armrest D.120

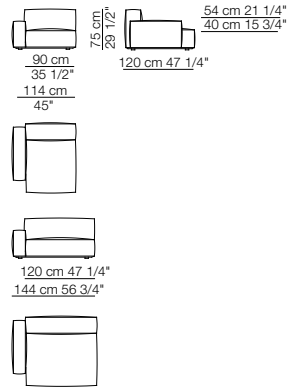

Elementi senza braccioli P.120
Units without armrests D.120

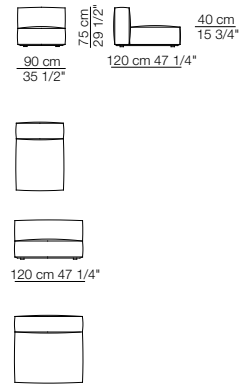

Elementi angolo P.120
Corner units D.120

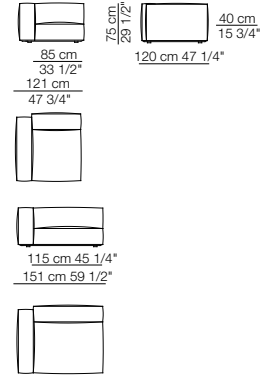

Elementi con 1 bracciolo lungo P.120
Units with 1 long armrest D.120

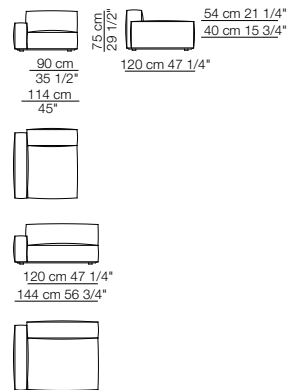

Elementi senza braccioli con schienale basso
Units without armrests with low backrest

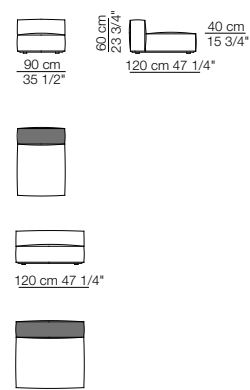

Pouf

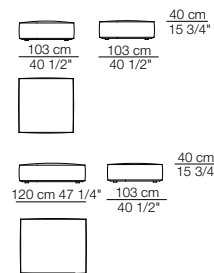
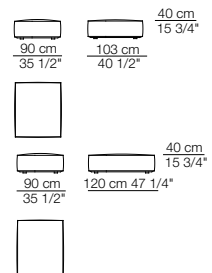
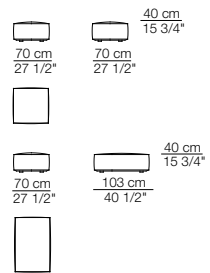

Composizioni
Compositions

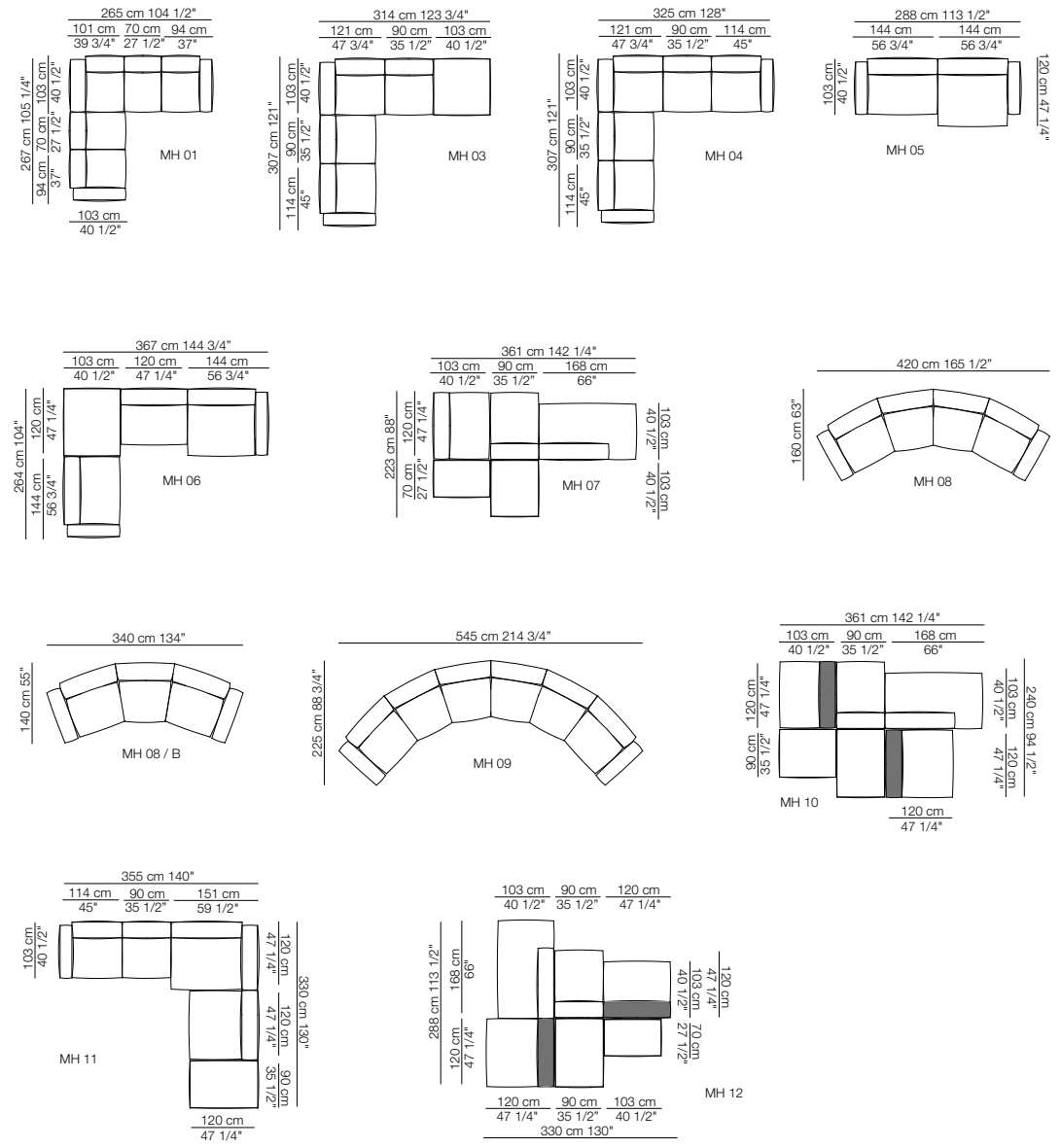



Marengo

Poltrone senza braccioli
Armchairs without armrests



Poltrona con 2 braccioli
Armchair with 2 armrests

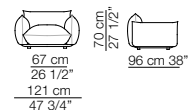

Divani
Sofas

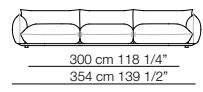
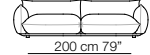
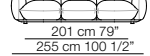
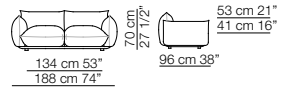

Elementi con 1 bracciolo
Units with 1 armrest

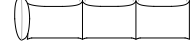
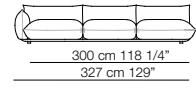
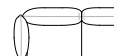
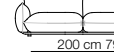
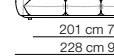
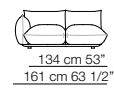

Elementi senza braccioli
Units without armrests

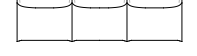
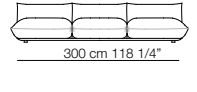
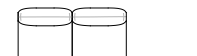
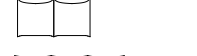
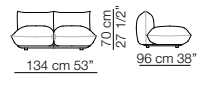

Pouf

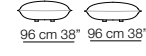
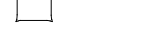
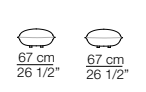

Elementi angolo
Corner units

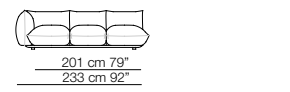
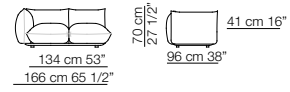

Elementi angolo con 1 bracciolo
Corner units with 1 armrest

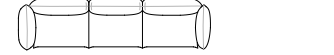
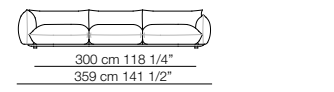
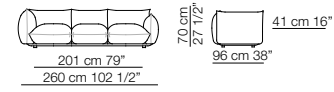

Elementi isola con angolo
Isle units with corner unit

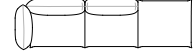
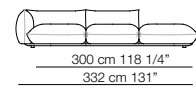
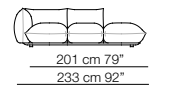

Composizioni
Compositions

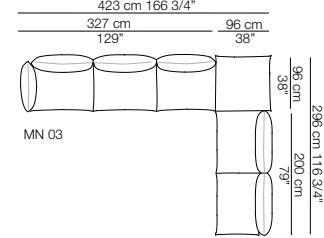
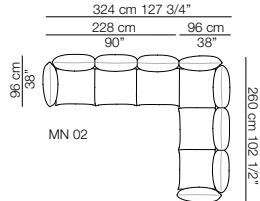
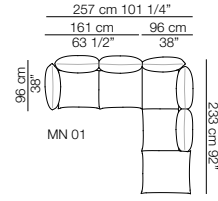

Naviglio

Divani
Sofas

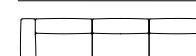
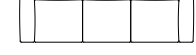
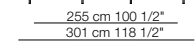
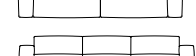
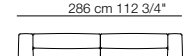
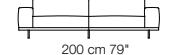
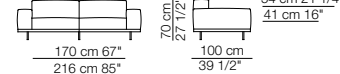

Elementi con 1 bracciolo
Units with 1 armrest

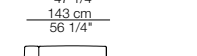
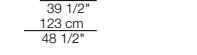
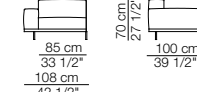

Pouf

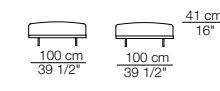

Composizioni
Compositions

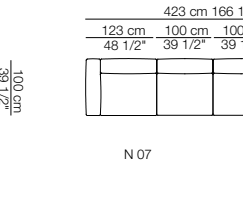
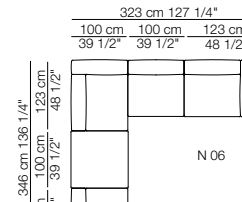
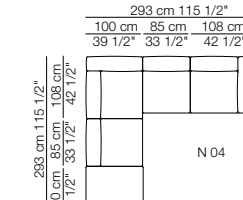
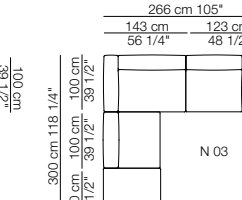
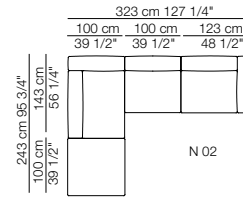
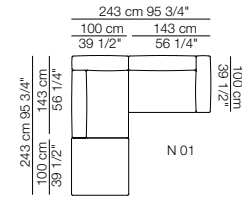



Rendez-vous D.95

Divani
Sofas

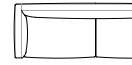
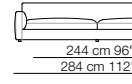
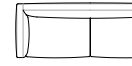
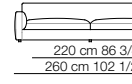
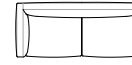
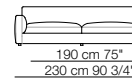
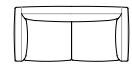
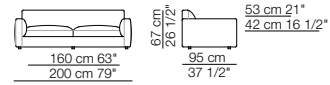

Divani con braccioli alti
Sofas with high armrests

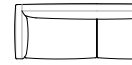
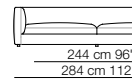
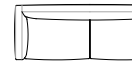
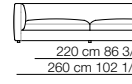
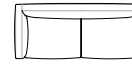
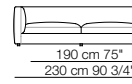
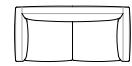
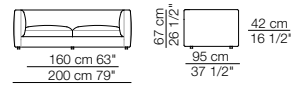

Elementi con 1 bracciolo
Units with 1 armrest

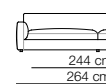
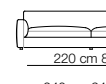
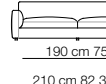
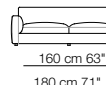
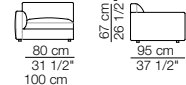

Elementi senza braccioli
Units without armrests

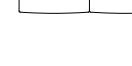
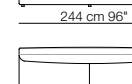
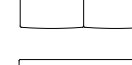
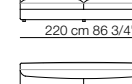
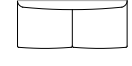
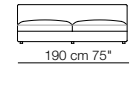

Elementi isola senza braccioli
Isle units without armrests

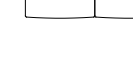
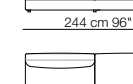
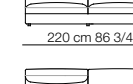
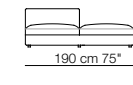

Elementi isola con angolo
Isle units with corner unit

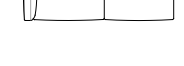
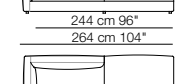
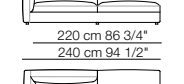
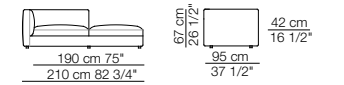

Elementi angolo / Elementi con 1 bracciolo alto
Corner units / Units with 1 high armrest

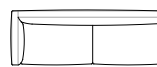
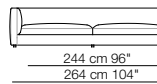
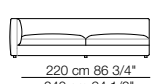
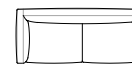
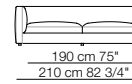
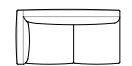
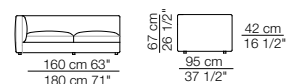

Elementi angolo con 1 bracciolo
Corner units with 1 armrest

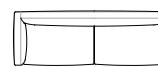
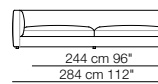
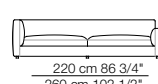
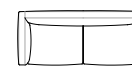
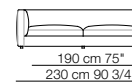

Chaise longue con 1 bracciolo basso
Chaise longue with 1 low armrest

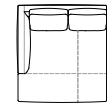
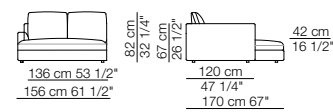

Pouf

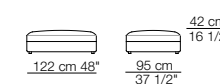
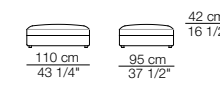
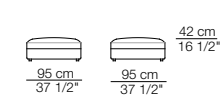

Cuscini schienale opzionali
Optional backrest cushions

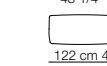
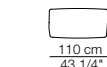
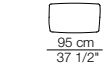
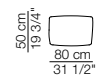

Cuscini schienale angolo
Backrest corner cushions

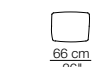
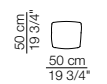

Divani / Sofas



Rendez-vous D.120

Divani
Sofas

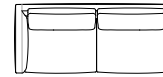
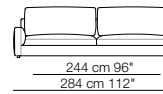
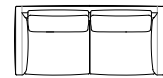
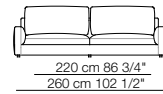
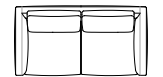
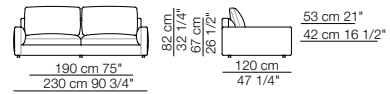

Divani con braccioli alti
Sofas with high armrests

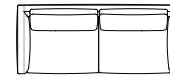
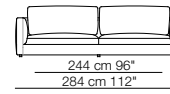
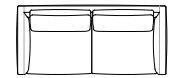
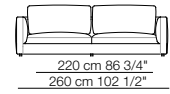
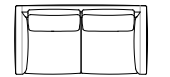
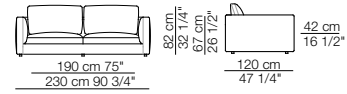

Elementi angolo con 1 bracciolo
Corner units with 1 armrest

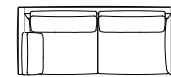
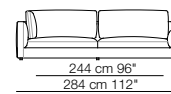
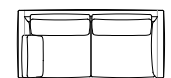
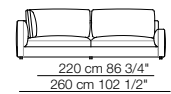
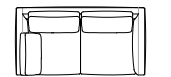
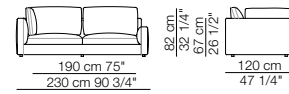

Elementi senza braccioli
Units without armrests

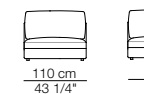
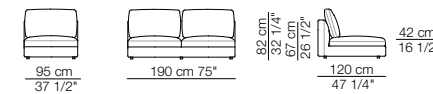

Elementi isola senza braccioli
Isle units without armrests

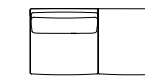
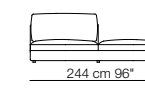
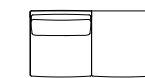
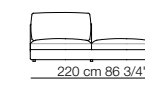
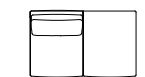
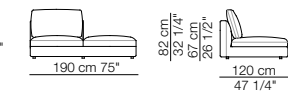

Elementi isola con angolo
Isle units with corner unit

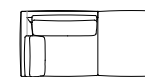
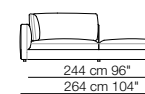
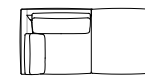
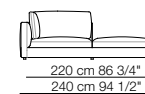
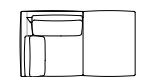
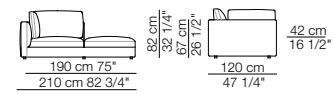

Elementi con 1 bracciolo
Units with 1 armrest

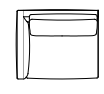
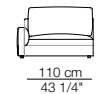
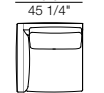
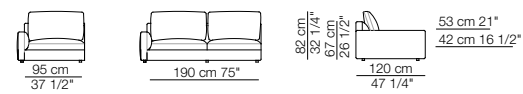

Elementi angolo / Elementi con 1 bracciolo alto
Corner units / Units with 1 high armrest

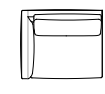
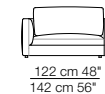
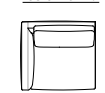
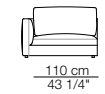
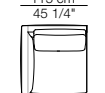
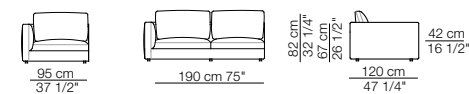

Chaise longue con 1 bracciolo basso
Chaise longue with 1 low armrest

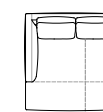
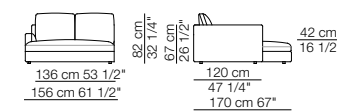

Pouf

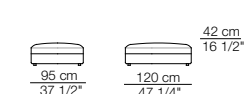

Cuscino schienale per angolo
Backrest cushion for corner unit



Rendez-vous D.95 - 120

Composizioni
Compositions

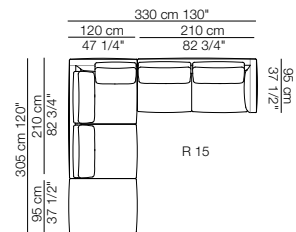
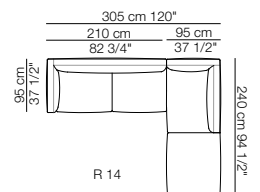
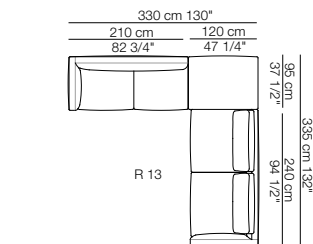
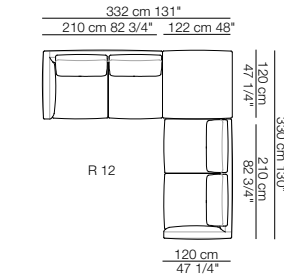
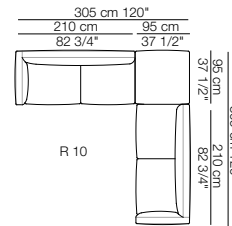
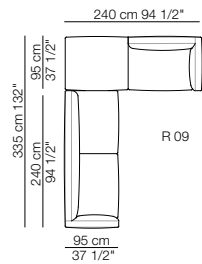
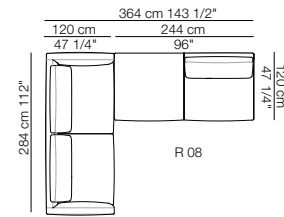
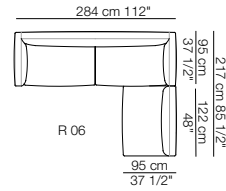
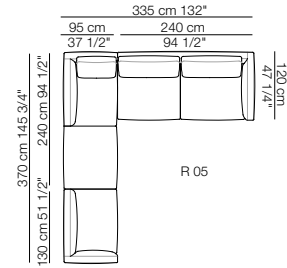
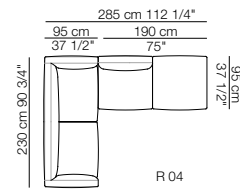
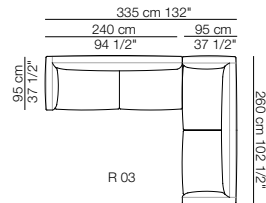
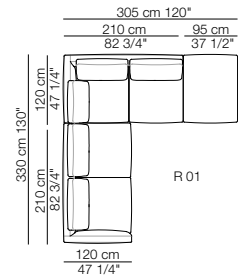

Soft Beat

Poltrona
Armchair

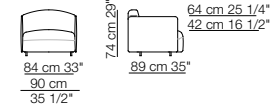

Divano
Sofa

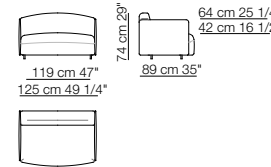

Elementi con 1 bracciolo
Units with 1 armrest



Elementi senza braccioli
Units without armrests



Chaise longue con 1 bracciolo
Chaise longue with 1 armrest



Chaise longue senza braccioli
Chaise longue without armrests



Elementi con 1 bracciolo
Units with 1 armrest



Elementi senza braccioli
Units without armrests



Chaise longue con 1 bracciolo
Chaise longue with 1 armrest



Chaise longue senza braccioli
Chaise longue without armrests



Chaise longue con 1 bracciolo
Chaise longue with 1 armrest

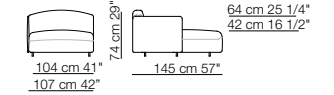

Chaise longue senza braccioli
Chaise longue without armrests

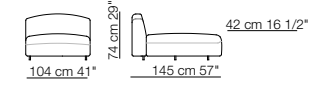

Composizioni
Compositions

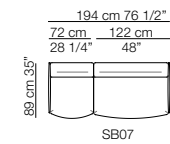
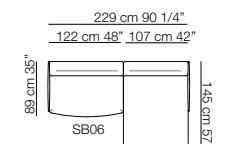
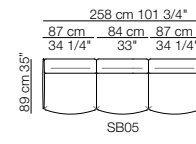
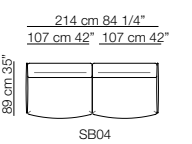
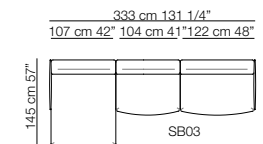
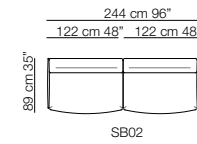
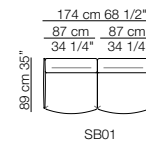



Strips

Divani Sofas

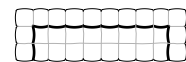
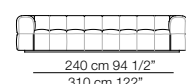
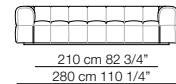
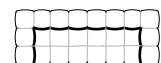
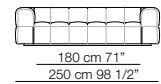
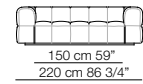
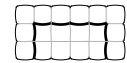
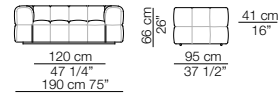

Elementi con 1 bracciolo Units with 1 armrest

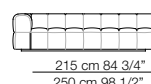
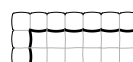
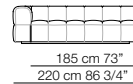
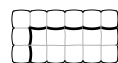
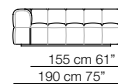
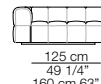
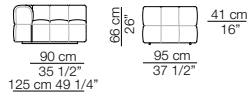

Elementi senza braccioli Units without armrests

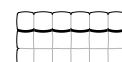
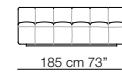
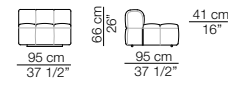

Divani P.125 Sofas D.125

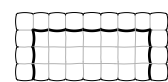
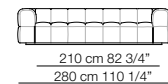
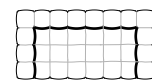
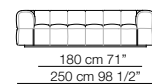
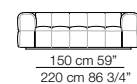
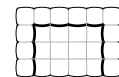
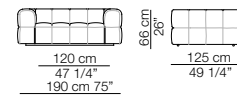

Divani con braccioli corti P.125 Sofas with short armrests D.125

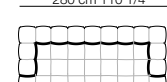
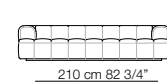
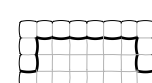
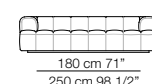
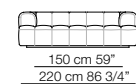
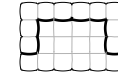
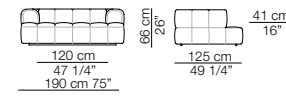

Elementi con 1 bracciolo P.125 Units with 1 armrest D.125

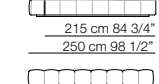
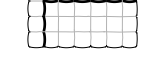
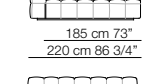
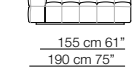
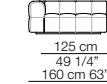
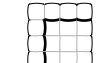
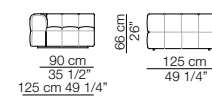

Elementi con 1 bracciolo corto P.125 Units with 1 short armrest D.125

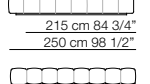
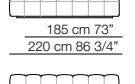
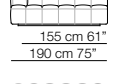
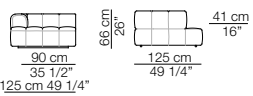

Elementi senza braccioli P.125 Units without armrests D.125

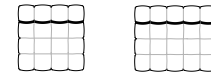
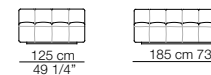
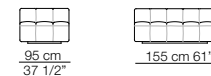

Pouf

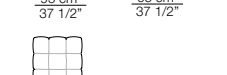
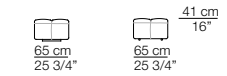

Cuscini arredo Soft Soft loose cushions



Composizioni
Compositions

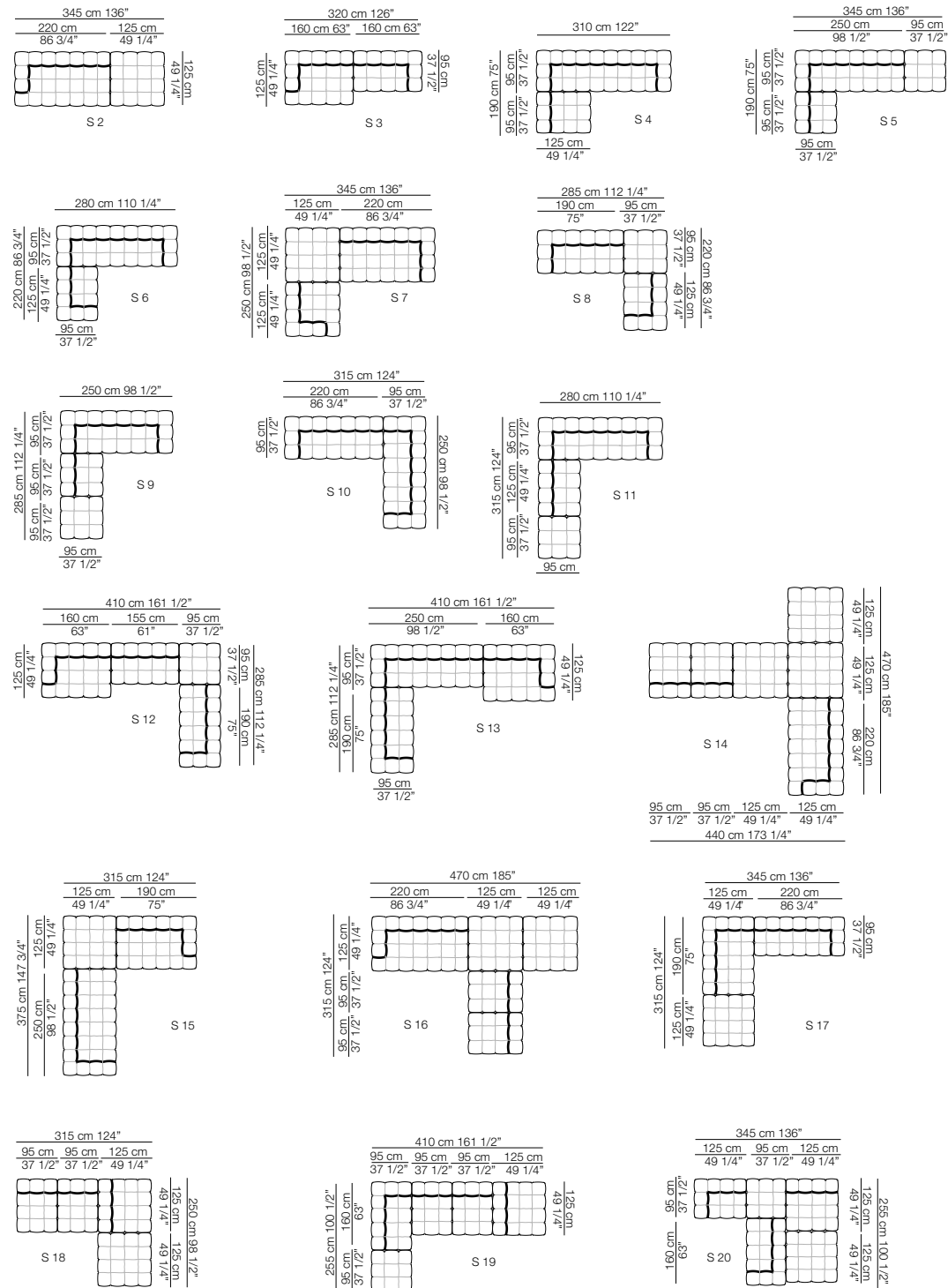

Tokio

Divani
Sofas

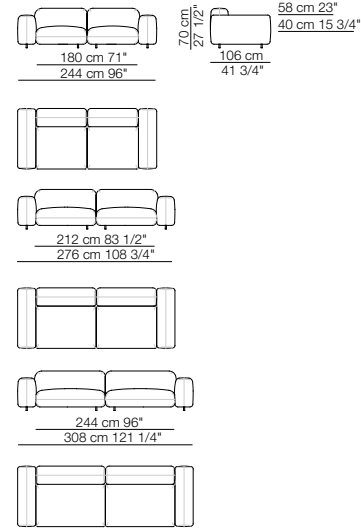

Elementi senza braccioli P.122
Units without armrests D.122

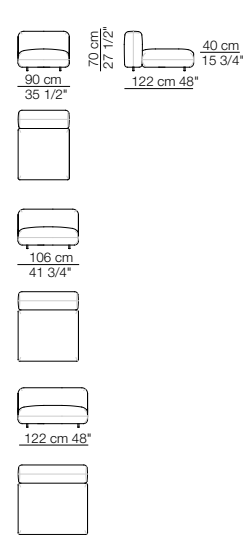

Elementi con 1 bracciolo P.106
Units with 1 armrest D.106

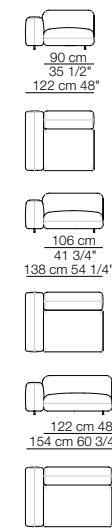

Elementi senza braccioli P.138
Units without armrests D.138

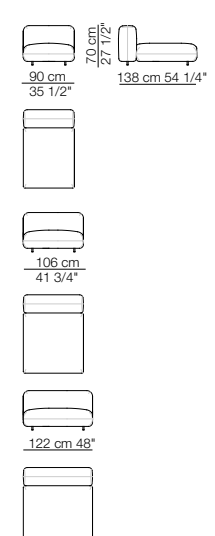

Elementi con 1 bracciolo P.122
Units with 1 armrest D.122

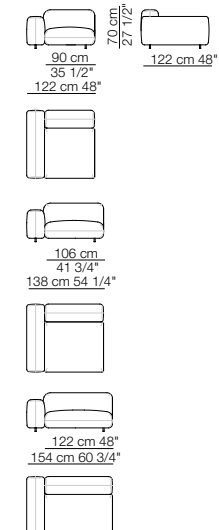

Elementi angolo P.106
Corner units D.106

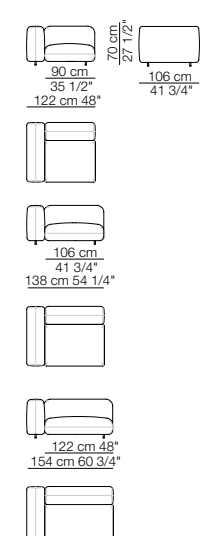

Elementi senza braccioli P.106
Units without armrests D.106

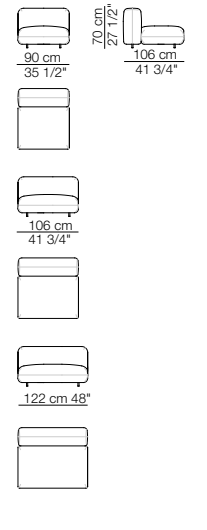

Elementi angolo P.122
Corner units D.122

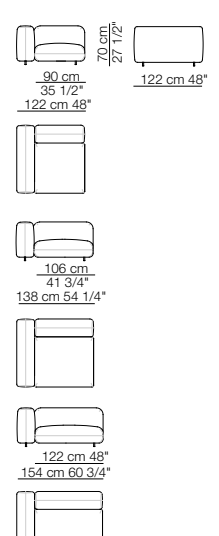

Divani / Sofas

Pouf

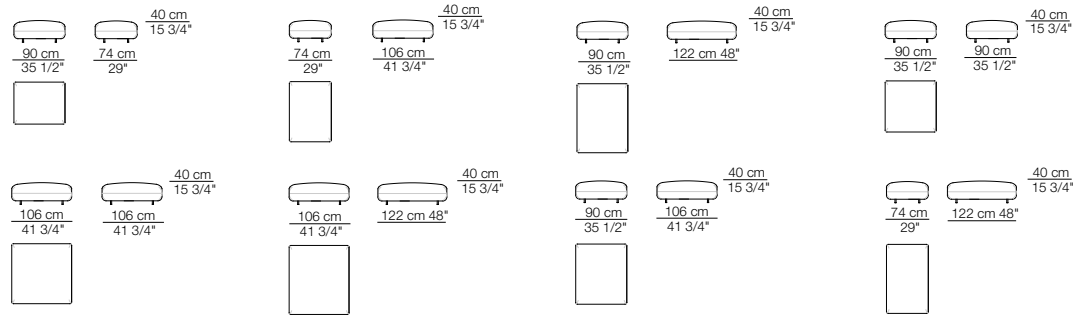

Composizioni
Compositions

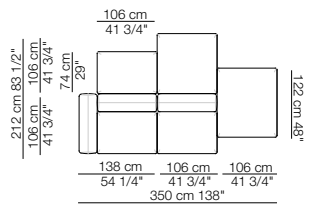

T 01

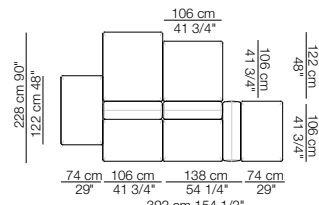

T 02

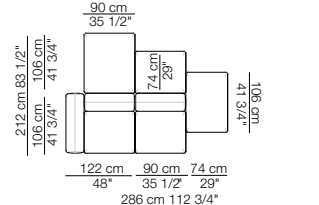

T 03

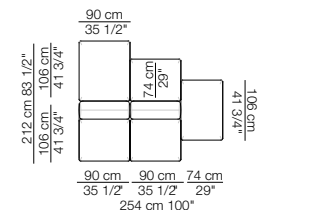

T 04

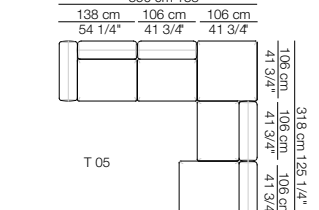

T 05

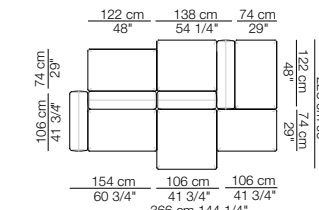

T 06

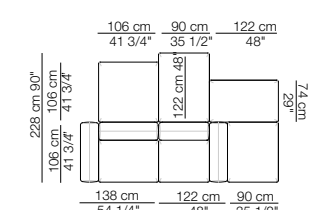

T 07

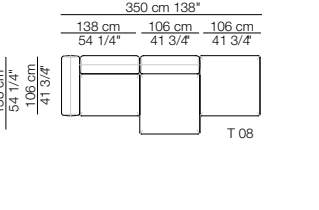

T 08

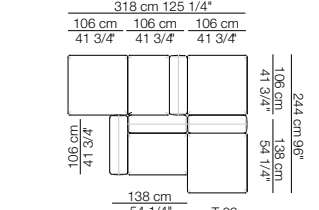

T 09

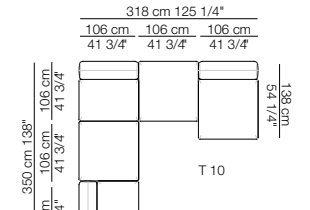

T 10

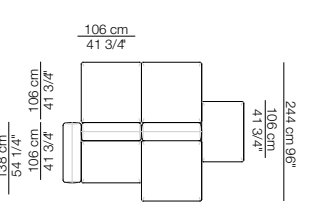

T 11

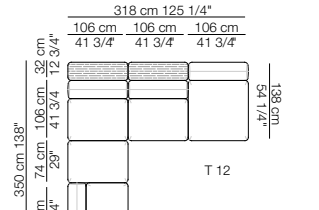

T 12

Poltrone / Armchairs



Poltrone / Armchairs



Delta Vienna
Poltrona
Armchair

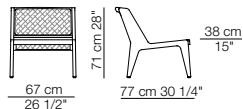

Elettra
Poltrona
Armchair

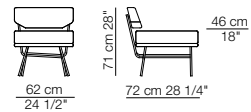

Hall
Poltrona
Armchair

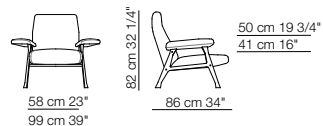

Gloria
Poltrona con schienale basso
Armchair with low backrest

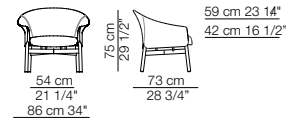

Fiorenza
Poltrona
Armchair

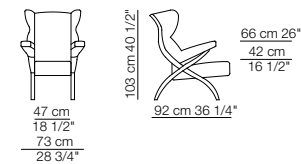

Hug
Poltrona con schienale basso
Armchair with low backrest

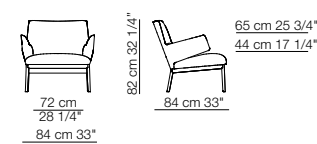

Gloria
Poltrona con schienale alto
Armchair with high backrest

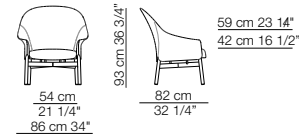

Giulietta
Poltrona
Armchair

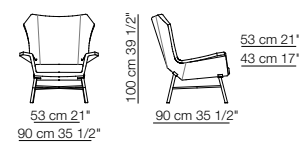

Hug
Poltrona con schienale alto
Armchair with high backrest

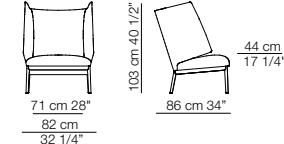

Ladle
Poltrona con schienale basso /
Basamento girevole a razze
Armchair with low backrest /
Swivel spoke base

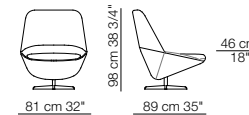

Poltrona con schienale basso /
Basamento in metallo
Armchair with low backrest /
Metal base



Leafo
Poltrona senza braccioli
Armchair without armrests

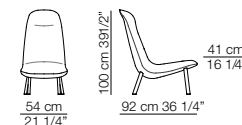

Ladle
Poltrona con schienale medio /
Basamento girevole a razze
Armchair with medium backrest /
Swivel spoke base

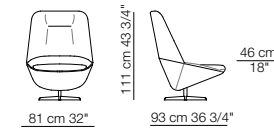

Poltrona con schienale medio /
Basamento in metallo
Armchair with medium backrest /
Metal base

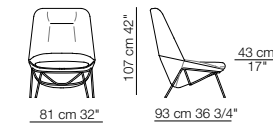

Leafo
Poltrona con 1 bracciolo (destra o sinistra)
Armchair with 1 armrest (right or left)

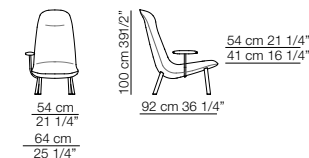

Ladle
Poltrona con schienale alto /
Basamento girevole a razze
Armchair with high backrest /
Swivel spoke base

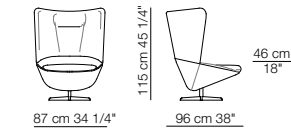

Poltrona con schienale alto /
Basamento in metallo
Armchair with high backrest /
Metal base

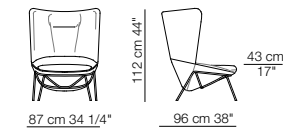

Leafo
Poltrona con 2 braccioli
Armchair with 2 armrests

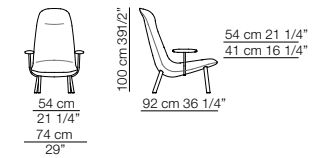

Pouf con basamento
a razze (non girevole)
Pouf with spoke base
(not swivel)

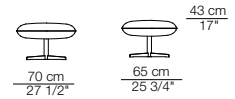

Poltrone / Armchairs



Jules
Poltrona
Armchair

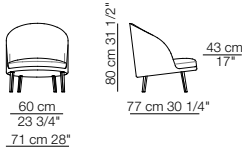

Jim
Poltrona
Armchair

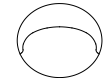
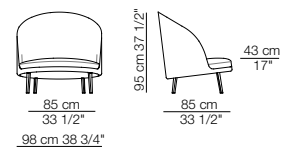

Pecorelle
Poltrona
Armchair

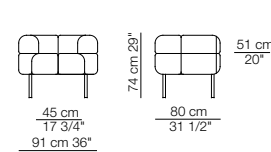

Sedie - Sgabelli / Chairs - Stools



Botolo
Poltrona versione bassa
Armchair low version

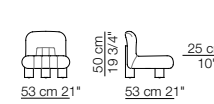

Botolo
Poltrona versione alta
Armchair high version

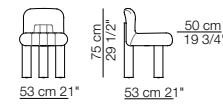

Elettra
Sedia
Chair

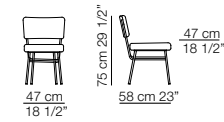

Hug
Sedia
Chair

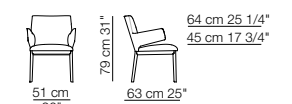

Katrin
Poltrona
Armchair

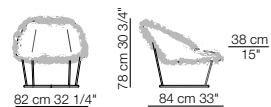

Serena & Doge
Poltrona Serena
Serena armchair

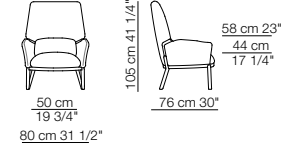

Pouf Doge

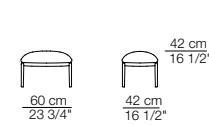

Lizzy
Sedia
Chair

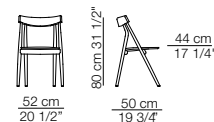

Neptunia
Sedia
Chair

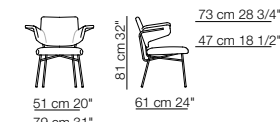

Orfeo
Sgabello H.102 cm
Stool H. 102 cm

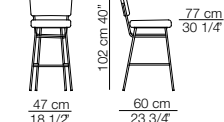

Suppli
Poltrona
Armchair

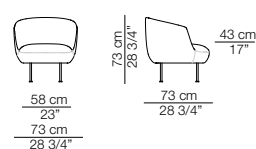

Tellin
Poltrona
Armchair

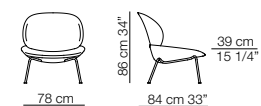

Virgola
Poltrona
Armchair

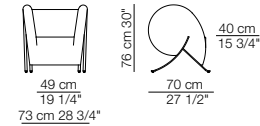

Sgabello H.92 cm
Stool H. 92 cm

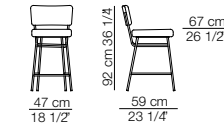

Dormeuse - Daybed



Banah
Dormeuse

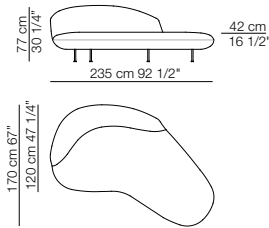

Bonsai
Divano con base in metallo
Sofa with metal base

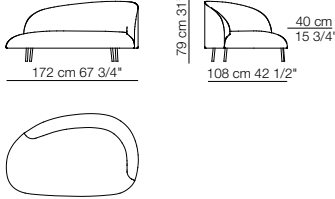

Divano con base in metallo e gonnella
Sofa with metal base and skirt

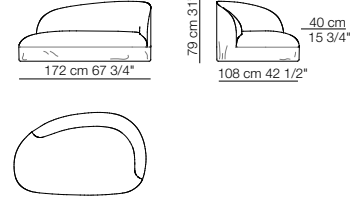

Cousy
Chaise longue con 2 braccioli
Chaise longue with 2 armrests

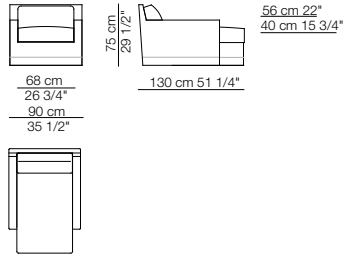

Hollywood
Chaise longue con 1 bracciolo
Chaise longue with 1 armrest

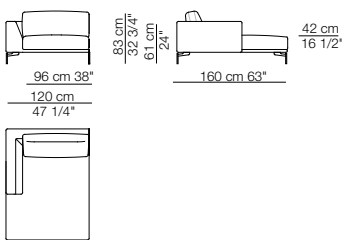

Sigmund
Panca
Bench

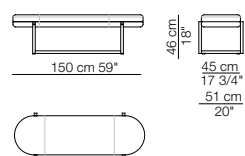

Sigmund
Daybed

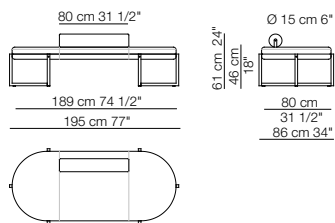

Tavoli / Tables



Goya lounge
Tavolo ø 90
Table ø 90

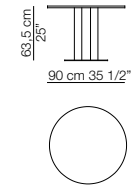

Tavolo 92 x 92
Table 92 x 92

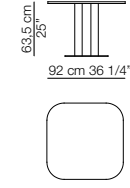

Tavolo ø 120
Table ø 120

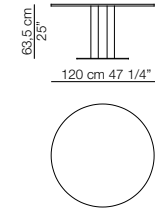

Tavolo 120 x 120
Table 120 x 120

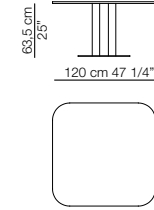

Goya lounge dining

Tavolo ø 90
Table ø 90

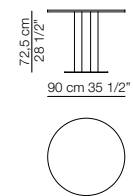

Tavolo 92 x 92
Table 92 x 92

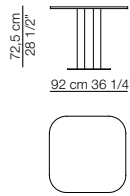

Tavolo ø 120
Table ø 120

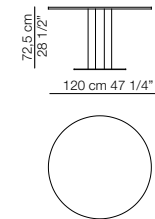

Tavolo 120 x 120
Table 120 x 120

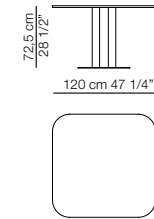

Tavolo ø 160
Table ø 160

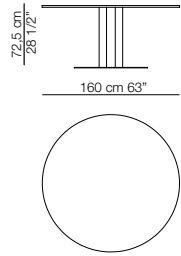

Hug
Tavolo
Table

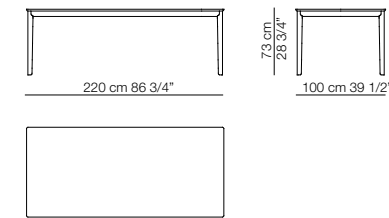



Arcolor
Tavolino ø 30
Small table ø 30

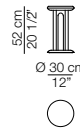

Arcolor
Tavolino ø 50
Small table ø 50

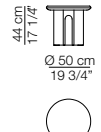

Arcolor
Tavolino ø 100
Small table ø 100

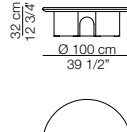

Bonsai
Tavolino
Small table

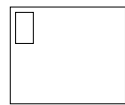
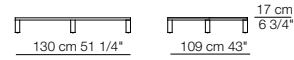

Infinity
Tavolino 105 x 105
Small table 105 x 105

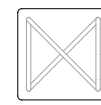
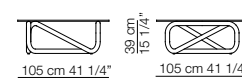

Infinity
Tavolino ø 130
Small table ø 130

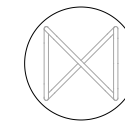
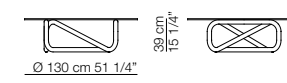

Match
Tavolino H.34 cm
Small table H.34 cm

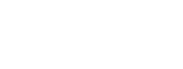
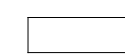
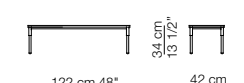

Match
Tavolino H.42 cm
Small table H.42 cm

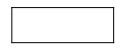
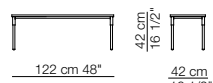

Capilano
Tavolino 55 x 55
Small table 55 x 55

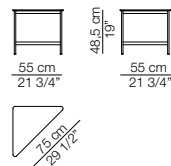

Capilano
Tavolino 96 x 30
Small table 96 x 30

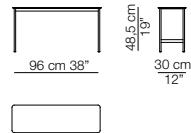

Capilano
Tavolino 187,5 x 30
Small table 187,5 x 30

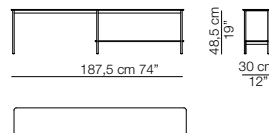

Cradle
Tavolino
Small table

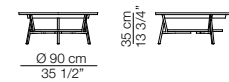

Island
Tavolino 56 x 56
Small table 56 x 56

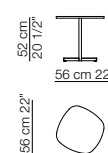

Island
Tavolino 98 x 98
Small table 98 x 98

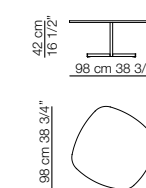

Island
Tavolino 120 x 60
Small table 120 x 60

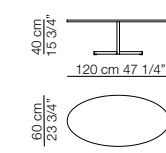

Island
Tavolino 140 x 50
Small table 140 x 50

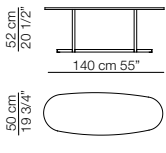

Goya
Tavolino ø 50
Small table ø 50

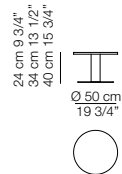

Tavolino 50 x 50
Small table 50 x 50

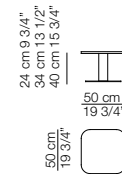

Service ø 50

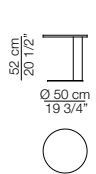

Service 50 x 50

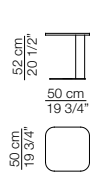

Tavolino 70 x 120
Small table 70 x 120

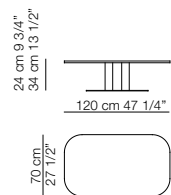

Tavolino ø 90
Small table ø 90

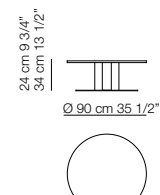

Tavolino 92 x 92
Small table 92 x 92

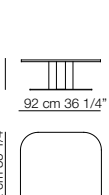

Tavolino ø 120
Small table ø 120

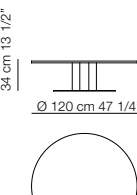

Tavolino 120 x 120
Small table 120 x 120

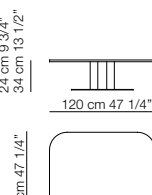

Sigmund
Tavolino 47 x 36
Small table 47 x 36

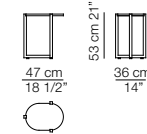

Sigmund
Tavolino 120 x 49
Small table 120 x 49

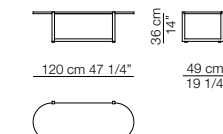

Tablet
Tavolino ø 50 H.31 cm
Small table ø 50 H.31 cm

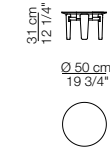

Tablet
Tavolino ø 50 H.43 cm
Small table ø 50 H.43 cm

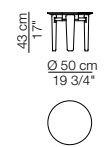

Tablet
Tavolino ø 80 H.31 cm
Small table ø 80 H.31 cm

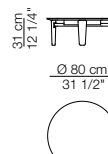

Tablet
Tavolino ø 80 H.43 cm
Small table ø 80 H.43 cm

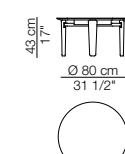

Tablet
Tavolino 109 x 109 H.31 cm
Small table 109 x 109 H.31 cm

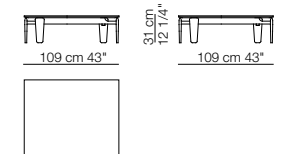

Tavolini / Small tables



Tokio
Service Ø 40

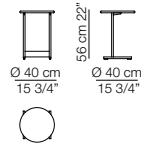

Tokio
Service 106 x 32

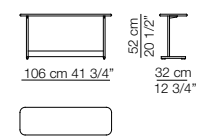

Tokio
Tavolino 106 x 106
Small table 106 x 106

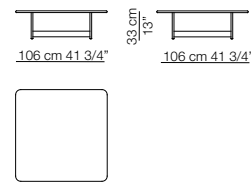

Tokio
Tavolino Ø 120
Small table Ø 120

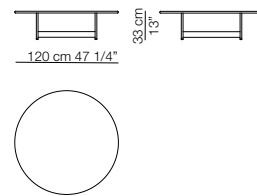

Tokio
Modulo con ripiano 106 x 32
Module with shelf 106 x 32

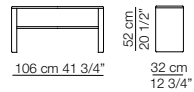

Tokio
Tavolino con cassetto 106 x 74
Small table with drawer 106 x 74

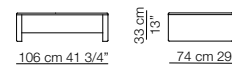

Scalea
Tavolino Ø 45
Small table Ø 45

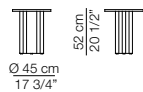

Scalea
Tavolino Ø 75
Small table Ø 75

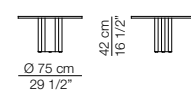

Librerie - Contenitori / Bookcases - Sideboards



Alba
Composizione libreria con 2 moduli
Bookcase composition with 2 units

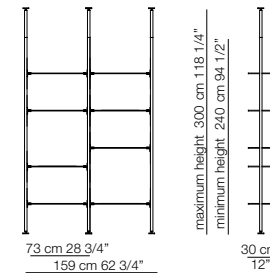

Composizione libreria con 3 moduli
Bookcase composition with 3 units

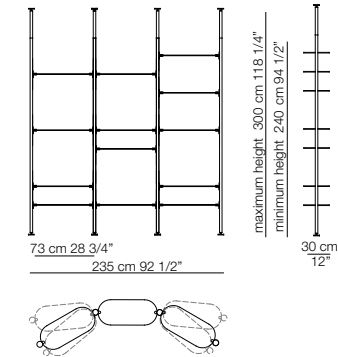

Composizione libreria con 4 moduli
Bookcase composition with 4 units

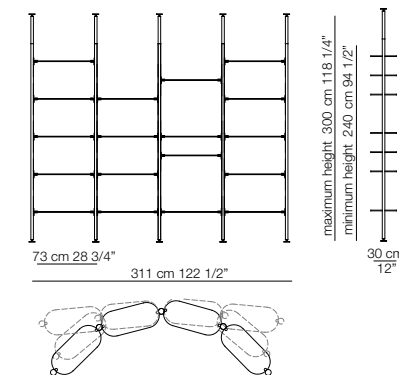



Match

Composizione libreria
Bookcase composition

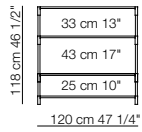

Composizione libreria
Bookcase composition

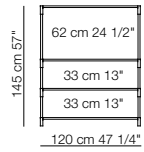

Composizione libreria
Bookcase composition

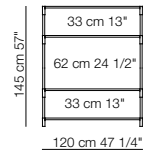

Composizione libreria
Bookcase composition

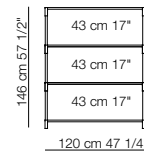

Composizione libreria
Bookcase composition

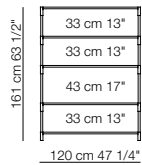

Composizione libreria
Bookcase composition

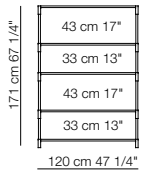

Composizione libreria
Bookcase composition

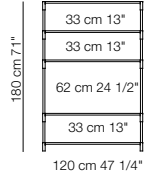

Composizione libreria
Bookcase composition

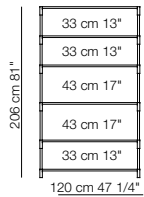

Rubycon

Contentore 2 moduli
Sideboard 2 cubes

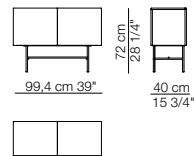

Contentore 3 moduli
Sideboard 3 cubes

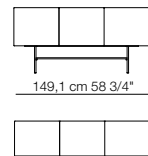

Contentore 4 moduli
Sideboard 4 cubes

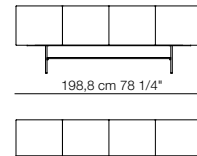

Contentore 5 moduli
Sideboard 5 cubes

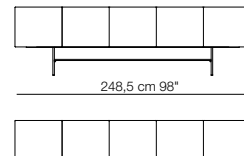

Diva

Accessorio
Accessory

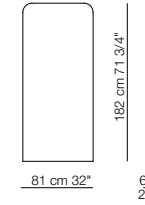

Panel A

Accessorio
Accessory

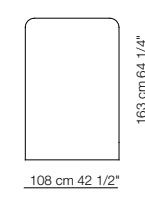

Panel B

Accessorio
Accessory

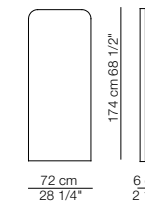

Panel C

Accessorio
Accessory

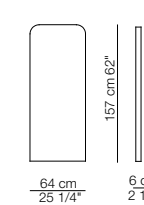

Panel D

Accessorio
Accessory

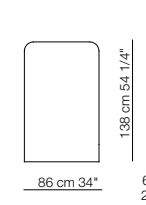

Panel E

Accessorio
Accessory

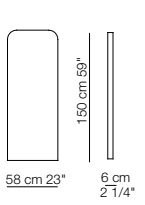

Panel F



Ciclope

Specchio
Mirror

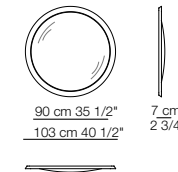

Delfino

Pouf

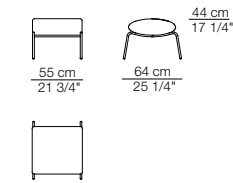

Doge

Pouf

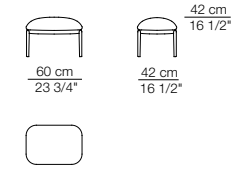

Match

Console

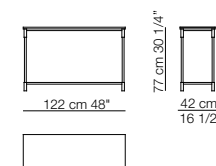



Penta
Pouf

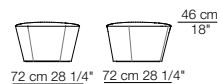

Penta
Pouf

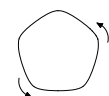
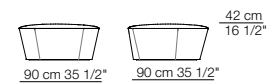

Penta
Pouf

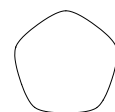
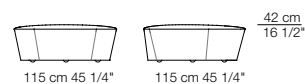

Pouf
Pouf

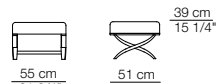

Papillon
Lampada da parete
Wall lamp

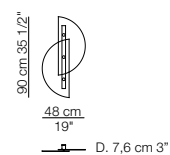

Ponti
Scrivitoio
Writing desk

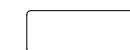
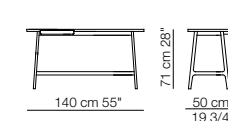

Sigmund
Scrivitoio
Writing desk

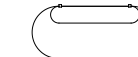
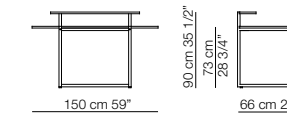

Vela
Accessorio
Accessory

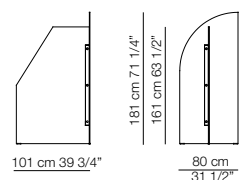

Code **A**
Colori : rosa e azzurro
Colours : pink and light blue



Vela
Accessorio
Accessory

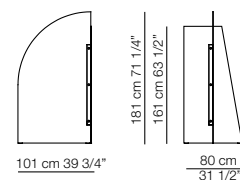

Code **C**
Colori : verde e azzurro
Colours : green and light blue



Vela
Accessorio
Accessory

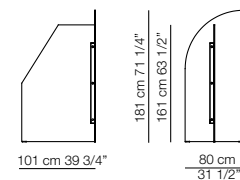

Code **D**
Colori : rosa e bronzo
Colours : pink and bronze



Threshold
Mobile specchiera basso
Low mirror cabinet

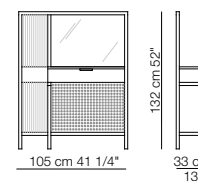

Mobile specchiera alto
High mirror cabinet

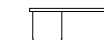
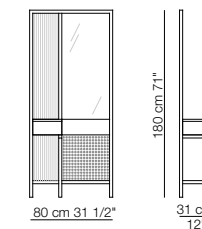

Contacts

arflex

via Pizzo Scalino 1
20833 Giussano (MB)
Italy
Tel +39 0362 853043
Fax +39 0362 354010
Skype : arflexdesign
www.arflex.com
info@arflex.it

Credits

Photography

Gumiero Walter
IKB
Lovatti Davide
Pagani Thomas

AD

Bernhardt-Vella

Styling

Bernhardt-Vella

Printed

May 2022

Copyright

seven salotti spa
All rights reserved 2022

Thanks to

Atelier Areti
CCtapis
Michele Reginaldi
Rob Sherwood
Schiavo Zoppelli Gallery