

2017 TECHNICAL BOOK **arketipo**  
*firenze*



# 2017 TECHNICAL BOOK



# TABLE OF CONTENTS

## SOFAS



## ARMCHAIRS



## BEDS



## SMALL TABLES



## DINING TABLES



## CHAIRS



## COMPLEMENTS



## LAMPS

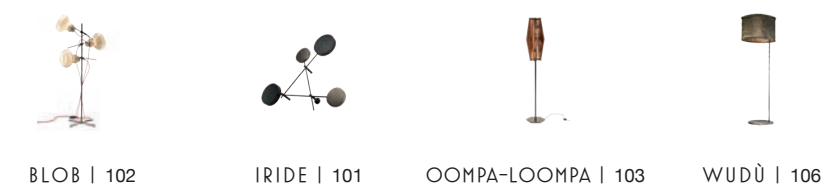

## MATERIALS | 108

# ATLAS



design  
Mauro Lipparini 2016

**Structure** wood **Structure upholstery** expanded polyurethane of varied densities (PF35FR+T40P+TL30 + NF21), covered with 100% cotton lining, wadding 380gr and coupled synthetic lining 6mm **Seat cushion upholstery** expanded polyurethane of varied densities (T35+40MH6+SOFF35S), covered with cotton and resin lining **Back cushion upholstery** outer cover in 100% down proof cotton and resin lining; filling in mixed down (70% goose down and 30% polyester fibre) **Springing** elastic belts **Back support** metal structure with elastic belts, covered with coupled synthetic lining 6mm. **Seat height** 41 cm **Arm height** 53 cm (LARGE) 47 cm (SLIM) **Feet** metal, finishes: micaceous brown, oxy grey or black nickel, h.5 cm **Piping** available in the following colours: white (100), cream white (101), mustard (102), beige (103), green (104), brown (105), dark brown (106), burgundy (107), purple (108), light grey (109), dark grey (110), sand beige (111), olive grey (112), slate grey (113), light blue grey (114) and aquamarine blue (115)

**Struttura** legno **Imbottitura struttura** poliuretano espanso a quote differenziate (PF35FR+T40P+TL30 + NF21), rivestito con accoppiato in cotone 100%, ovatta gr.380 e fodera di vellutino accoppiato 6mm **Imbottitura cuscino seduta** poliuretano espanso a quote differenziate (T35+40MH6+SOFF35S), rivestito con resinato accoppiato con cotone 100% **Imbottitura cuscini schienale** rivestimento in cotone antipiuma accoppiato a resinato; riempitura in misto piuma (70% piuma d'oca e 30% fibra di poliestere) **Piano di molleggio** cinghie elastiche **Schienetta** struttura in metallo con cinghie elastiche, rivestita con fodera di vellutino accoppiato 6mm **Altezza seduta** 41 cm **Altezza bracciolo** 53 cm (LARGE) 47 cm (SLIM) **Piedi** metallo, finiture: marrone micaceo, oxy grey o black nickel, h.5 cm **Bordino** disponibile nei colori: bianco (100), crema (101), senape (102), beige (103), verde (104), marrone (105), testa di moro (106), bordeaux (107), viola (108), grigio chiaro (109), grigio scuro (110), sabbia (111), grigio oliva (112), grigio ardesia (113), grigio azzurro (114) e acqua marina (115)

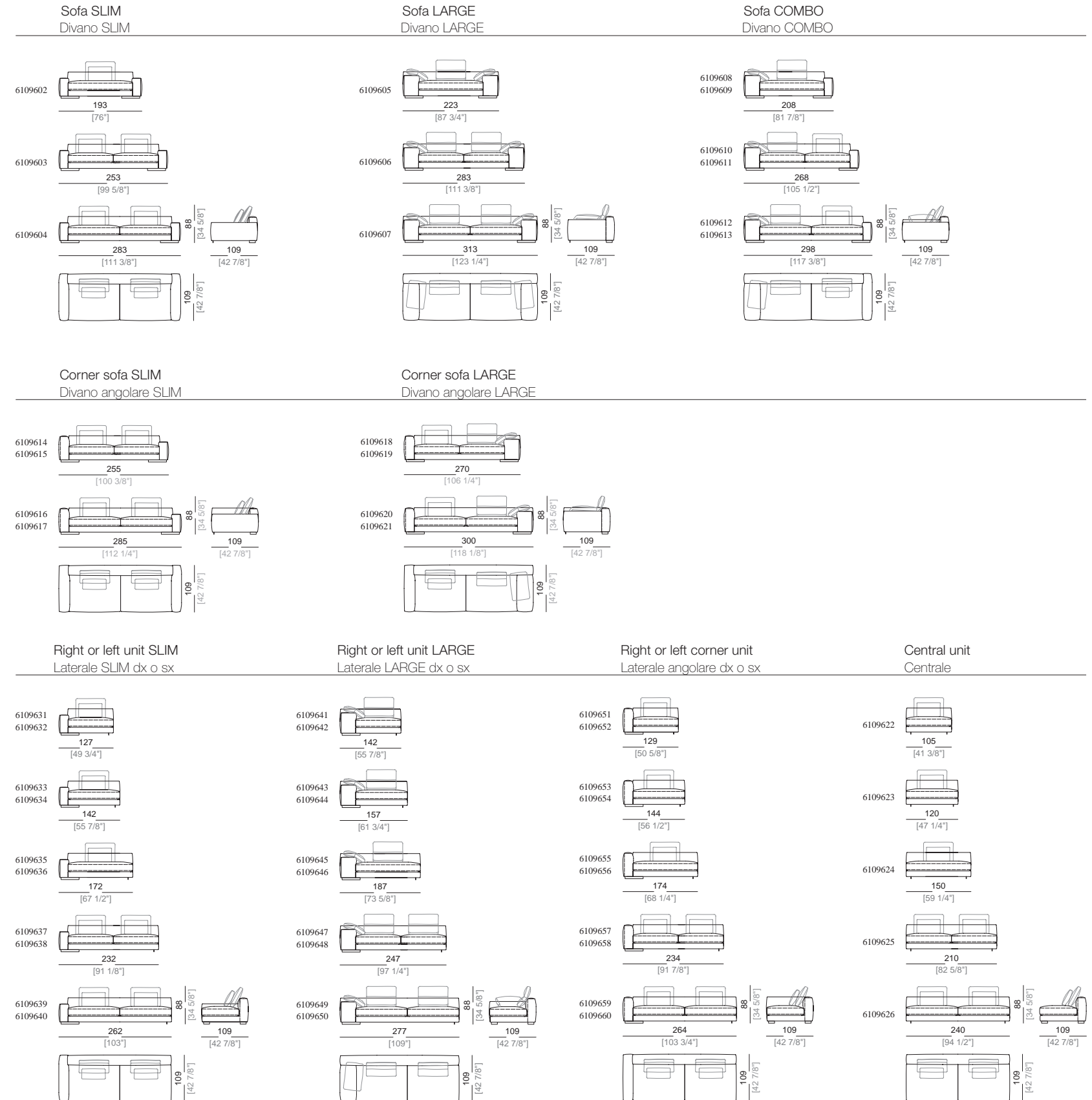

Unit SLIM with right or left pouf  
Laterale SLIM con pouf dx o sx

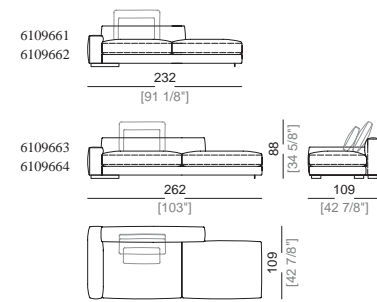

Unit LARGE with right or left pouf  
Laterale LARGE con pouf dx o sx

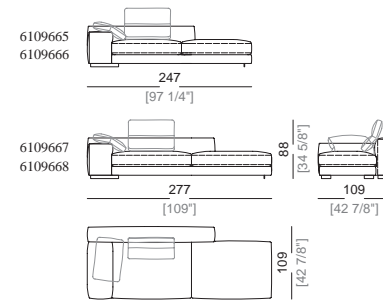

Right or left corner unit with right or left pouf  
Laterale angolare dx o sx con pouf dx o sx

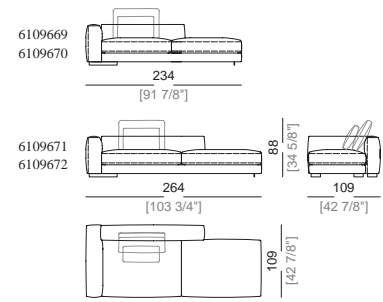

Central unit with right or left pouf  
Elemento centrale con pouf dx o sx

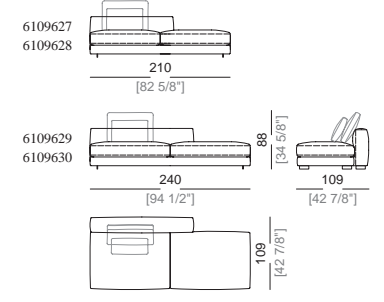

Unit SLIM with right or left back  
Laterale SLIM con schienale dx o sx

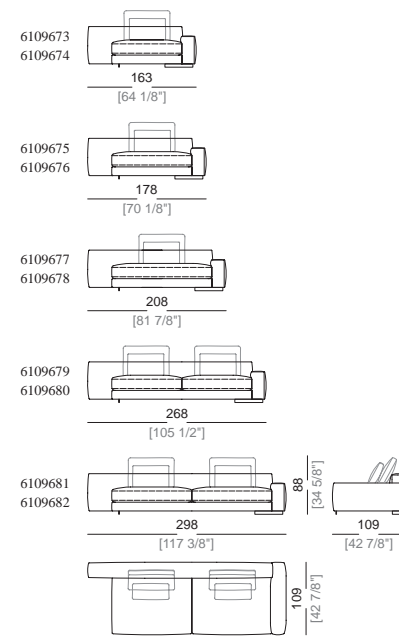

Unit LARGE with right or left back  
Laterale LARGE con schienale dx o sx

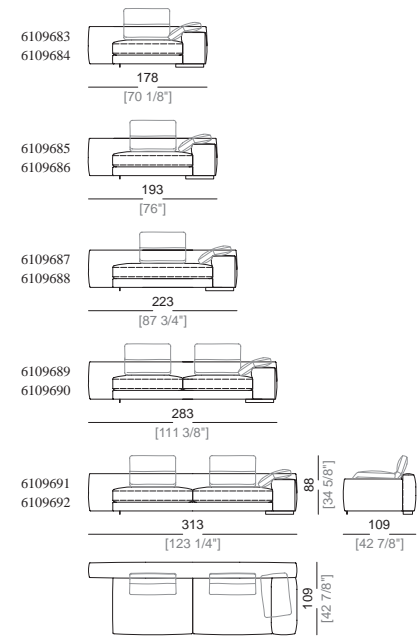

Central unit with right or left back  
Centrale con schienale dx o sx

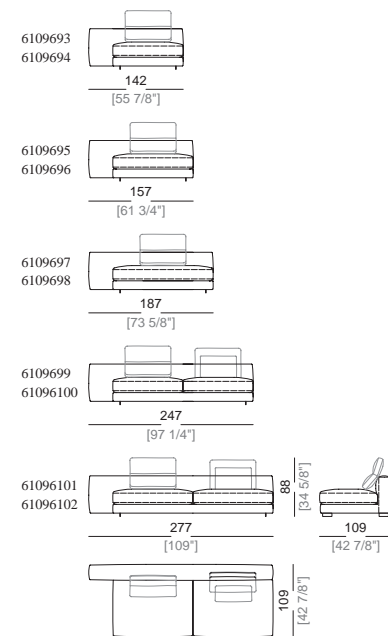

Chaise-longue SLIM with right or left short arm  
Chaise longue SLIM dx o sx

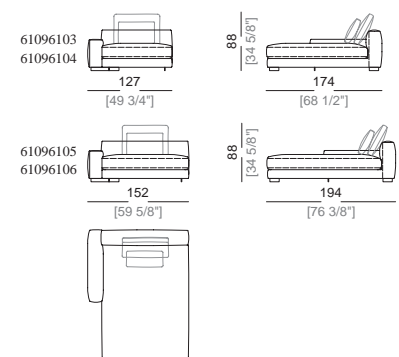

Chaise-longue LARGE with right or left short arm  
Chaise longue LARGE dx o sx

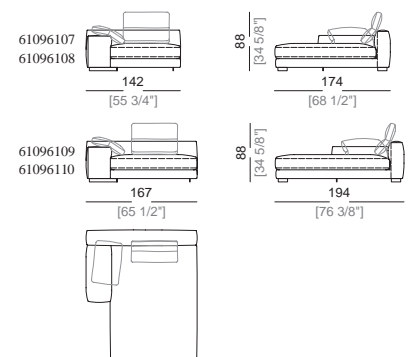

Dormeuse  
Dormeuse

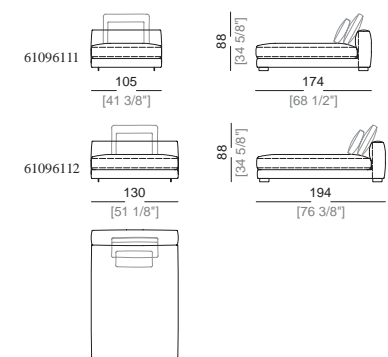

Pouf  
Pouf

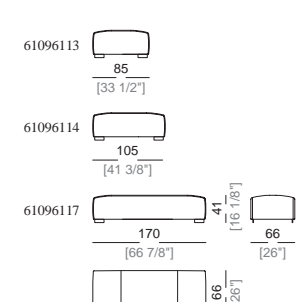

Pouf  
Pouf

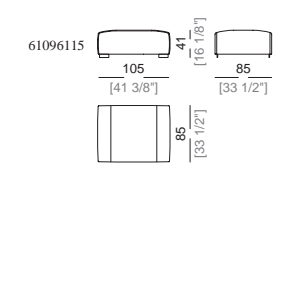

Pouf  
Pouf

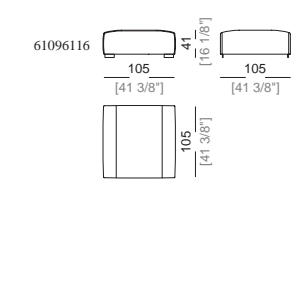

Composition A  
Composizione A

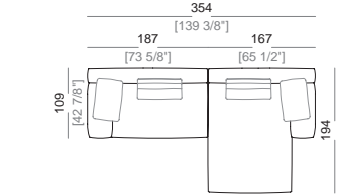

Composition B  
Composizione B

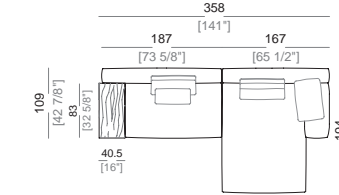

Composition C  
Composizione C

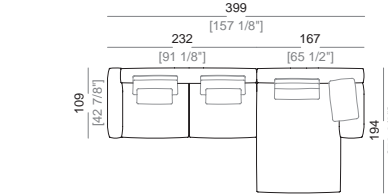

Composition D  
Composizione D

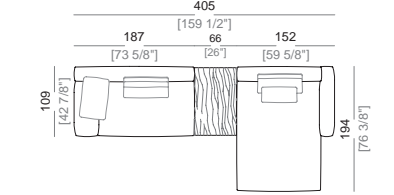

Composition F  
Composizione F

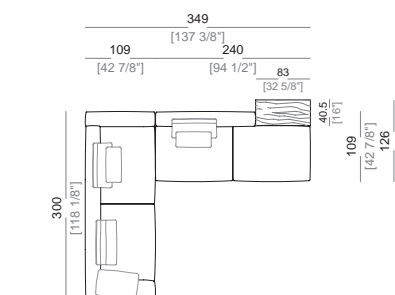

Composition G  
Composizione G

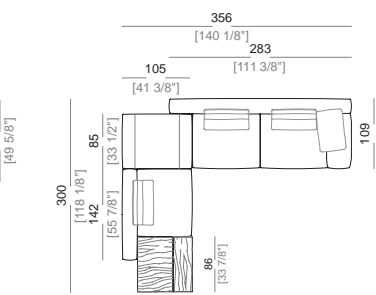

Composition H  
Composizione H

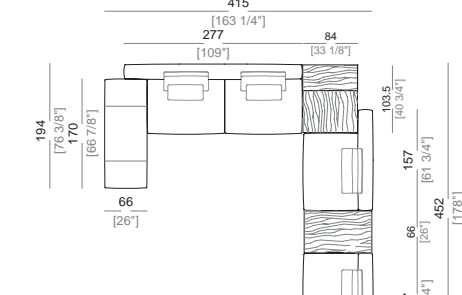

Composition L  
Composizione L

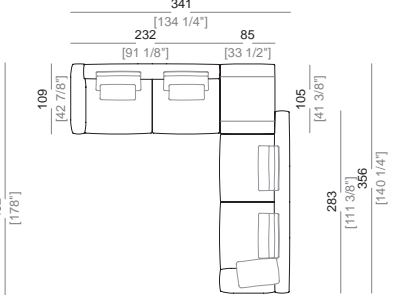

Composition M  
Composizione M

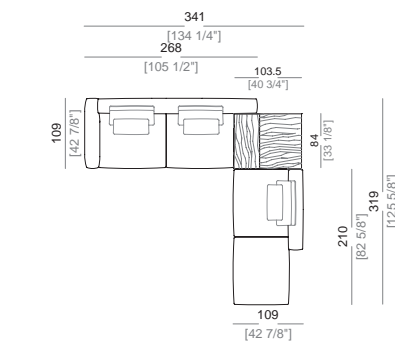

Composition N  
Composizione N

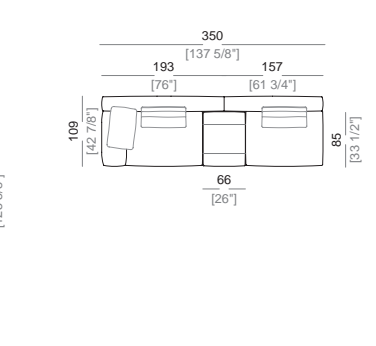

# AUTO-REVERSE



design  
Giuseppe Viganò 2013

**Structure** metal **Frame upholstery** non-deformable polyurethane (D35EM + D70) covered with coupled synthetic lining 6 mm **Seat cushion upholstery** outer side in 100% white Gabardine 30/20 cotton cover; filling in 65% goose down and 35% duck down; inner core in expanded polyurethane (PF35) **Back cushion upholstery** outer side in 100% white Gabardine 30/20 cotton cover; filling in 65% goose down and 35% duck down; inner core in expanded polyurethane (T18/S) **Arm cushion padding** outer side in white Gabardine 30/20 cotton cover; filling in 100% European goose down **Springing** elastic belts **Seat height** 43 cm **Arm height** 60 cm (structure), 74 cm (with cushion for arm) **Feet** metal, finishes: micaceous brown, titanium or brass, h. 17 cm **Zips** available in the following colours: white (100), cream white (101), mustard (102), beige (103), green (104), brown (105), dark brown (106), burgundy (107), purple (108), light grey (109), dark grey (110), sand beige (111), olive grey (112), slate grey (113), light blue grey (114) and aquamarine blue (115)

Seat and back cushions are reversible and they can be covered with different fabrics and/or leathers. The cover of the structure is always in the same fabric or leather of one side of the cushions

**Struttura** metallo **Imbottitura fusto** poliuretano indeformabile (D35EM + D70) rivestito con vellutino accoppiato (angera) spessore 6 mm **Imbottitura seduta** tessuto esterno in Gabardina 30/20 bianco (100% cotone). Imbottitura miscela con 65% di piuma d'oca e 35% piuma d'anatra, dima interna in poliuretano espanso (PF35) **Imbottitura schienale** tessuto esterno in Gabardina 30/20 bianco (100% cotone). Imbottitura miscela con 65% di piuma d'oca e 35% piuma d'anatra, dima interna in poliuretano espanso (T18/S) **Imbottitura bracciolo** tessuto esterno in Gabardina 30/20 bianco. Imbottitura 100% di piuma d'oca europea **Piano di molleggio** cinghie elastiche **Altezza seduta** 43 cm **Altezza bracciolo** 60 cm (struttura), 74 cm (con cuscino bracciolo) **Piedi** metallo finitura marrone micaceo, titanio o ottone, h.17 cm **Cerniere** disponibili nei colori: bianco (100), crema (101), senape (102), beige (103), verde (104), marrone (105), testa di moro (106), bordeaux (107), viola (108), grigio chiaro (109), grigio scuro (110), sabbia (111), grigio oliva (112), grigio ardesia (113), grigio azzurro (114) e acqua marina (115)

Le cuscinate sono double-face e possono essere realizzate con tessuti e pelli differenti. Il rivestimento della struttura è sempre uguale ad un lato delle cuscinate

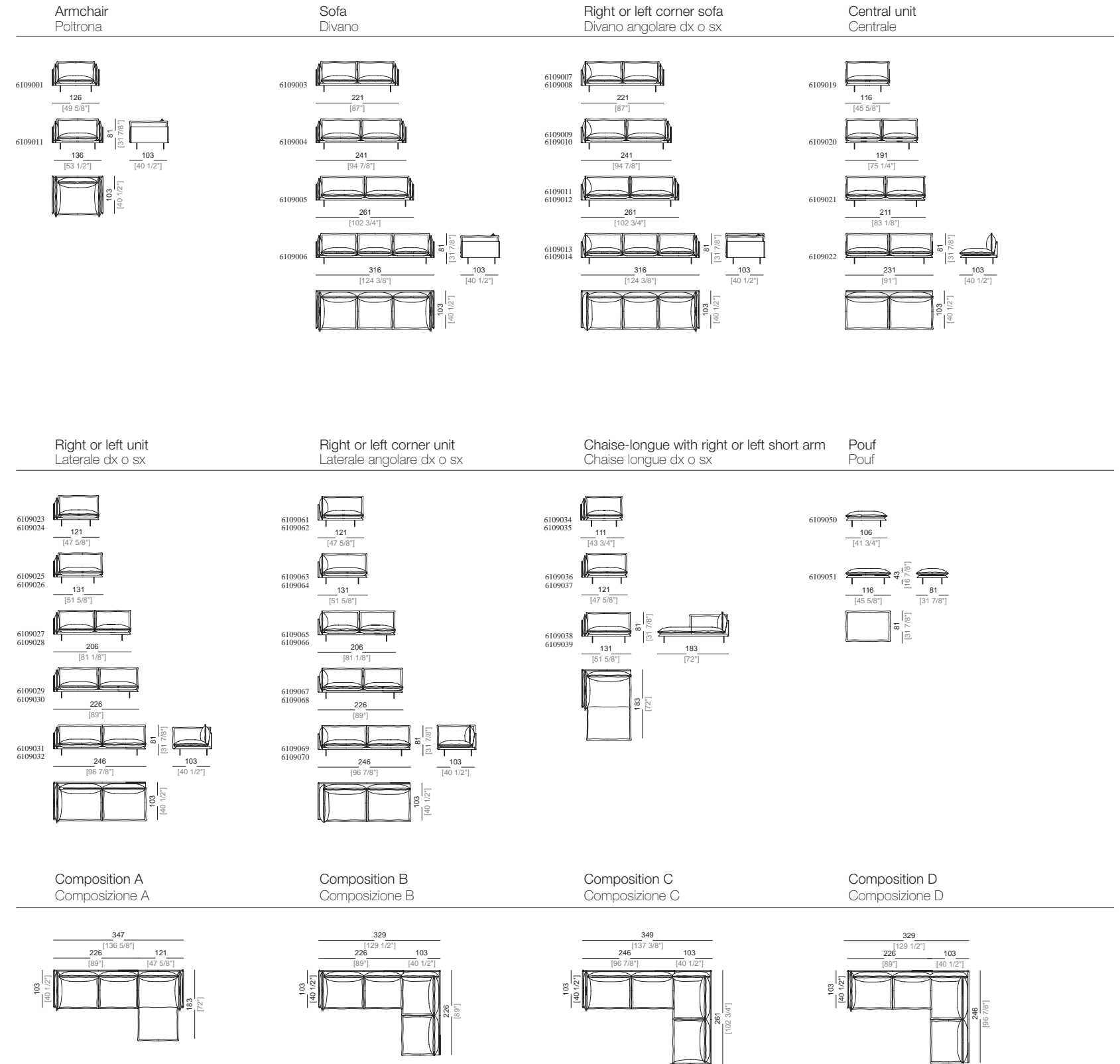

# BEST



design  
Carlo Bimbi 2005

**Structure** wood **Seat padding** non-deformable polyurethane D30 + D25I covered with synthetic lining 200 gr  
**Back padding** non-deformable polyurethane D211 + D21IP covered with Dacron **Frame padding** non-deformable polyurethane D32GR covered with synthetic lining 6 mm **Springing** beech wood slats **Seat height** 39 cm **Arm height** 52 cm **Feet** black wood with polished aluminium trim h. 5 cm

**Struttura** legno **Imbottitura cuscini seduta** poliuretano indeformabile D30 + D25I fasciato in tomana 200 gr **Imbottitura cuscini schienale** poliuretano indeformabile D211 + D21IP fasciato in Dacron **Imbottitura fusto** poliuretano indeformabile D32GR rivestito con fodera di vellutino accoppiato 6 mm **Piano di molleggio** lamelle di faggio **Altezza seduta** 39 cm **Altezza bracciolo** 52 cm **Piedi** legno nero con fascia in alluminio lucido h. 5 cm

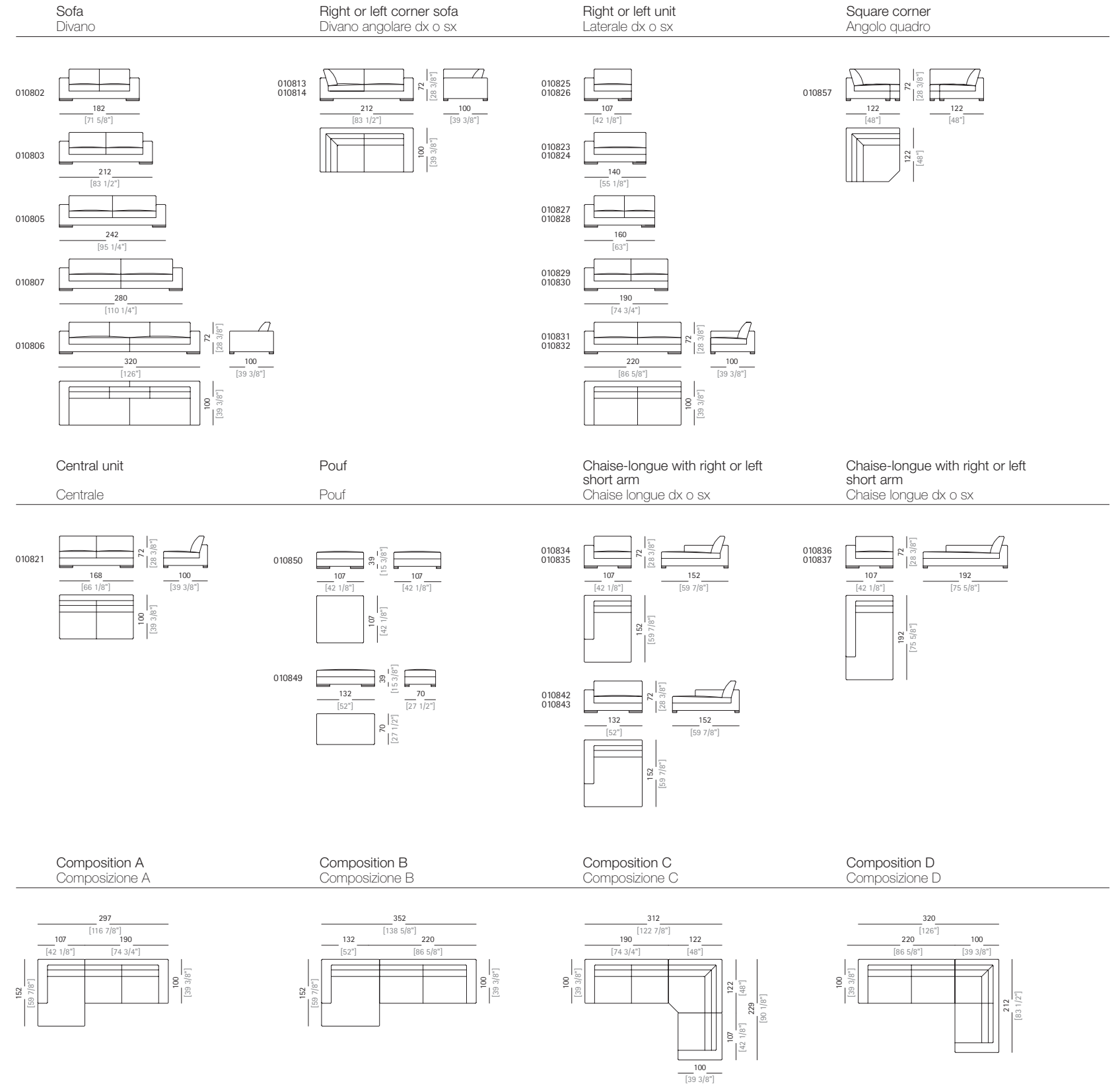

# CRAZY DIAMOND



design  
Giuseppe Viganò 2015

**Structure** wood **Seat upholstery** expanded polyurethane of varied densities (D35+D40+D50 Mind Foam®); outer cover in 100% downproof white cotton filled with down and synthetic lining 230gr **Back upholstery** expanded polyurethane of varied densities (D28+D21+D75); outer cover in 100% downproof white cotton filled with down and quilted synthetic lining 230gr **Arm upholstery** expanded polyurethane of varied densities (D35+D40); outer cover in 100% downproof white cotton filled with down and coupled Dacron 380gr **Springing** elastic belts **Seat height** 41 cm **Arm height** 58 cm **Feet** metal, finishes micaceous brown or titanium, h. 11,5 cm  
The back is supplied with a movement that allows two positions: a deep seat with high back and a reduced depth seat with a low back. The position can be changed through a simple action while seated

**Struttura** legno **Imbottitura fusto seduta** poliuretano espanso a quote differenziate (D35+D40+D50 Mind Foam®), rivestito con cotone 100% antipiroma bianco riempito in piuma naturale 100%, fianchi in tomana gr.230 **Imbottitura fusto schienale** poliuretano espanso a quote differenziate (D28+D21+D75), rivestito con cotone 100% antipiroma bianco riempito in piuma naturale 100%, fianchi in tomana trapuntata gr.230 **Imbottitura fusto bracciolo** poliuretano espanso a quote differenziate (D35+D40), rivestito con cotone 100% antipiroma bianco riempito con 100% di piuma naturale, fianchi interni in dacron accoppiato gr.380 **Piano di molleggio** cinghie elastiche **Altezza seduta** 41 cm **Altezza bracciolo** 58 cm **Piedi** metallo, finiture marrone micaceo o titanio, h.11,5 cm  
Lo schienale è ingegnerizzato per avere due posizioni: seduta profonda con schienale alto e profondità di seduta ridotta con schienale basso. La variazione di posizione si ottiene grazie ad un semplice gesto stando comodamente seduti

## Sofa Divano

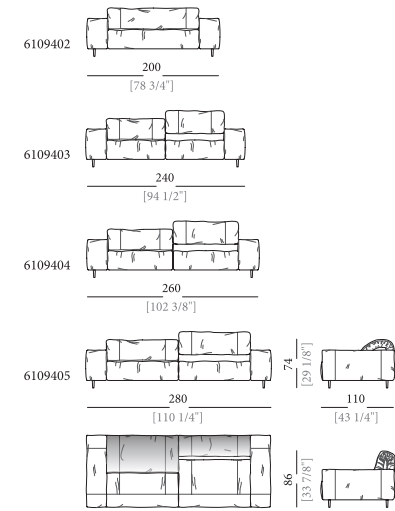

## Sofa made by 2 units Divano formato da due laterali

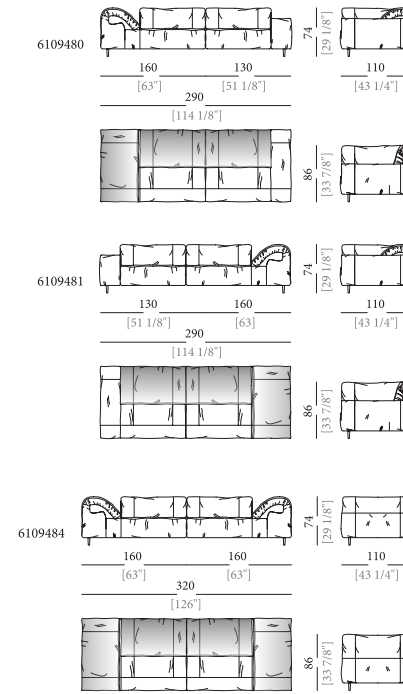

## Sofa made by 2 units Divano formato da due laterali

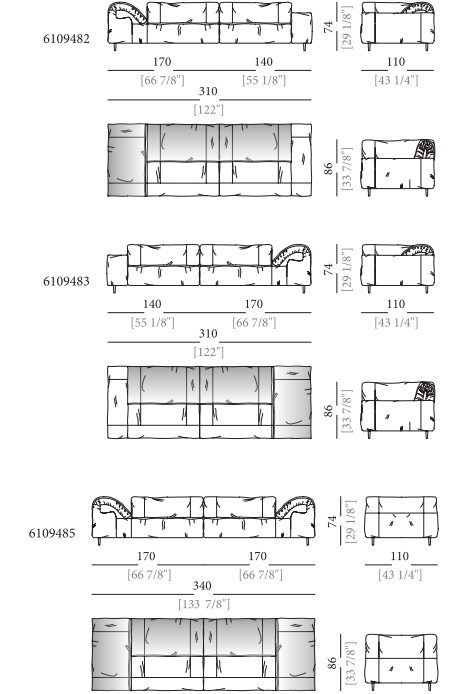

## Right or left unit Laterale dx o sx

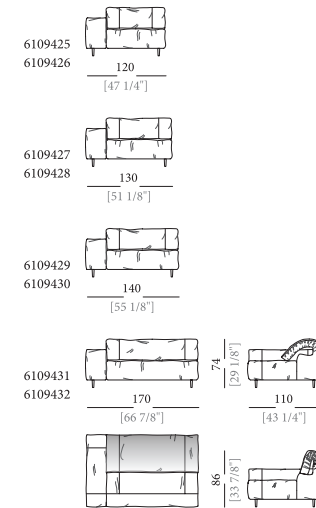

## Right or left unit Laterale dx o sx

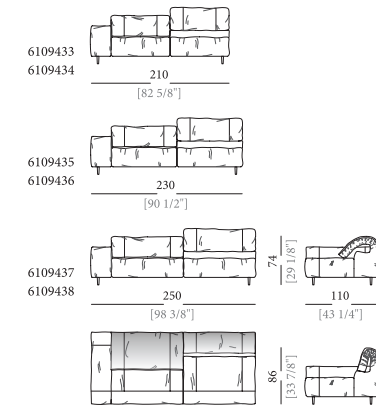

## Unit with right or left pouf Laterale con pouf dx o sx

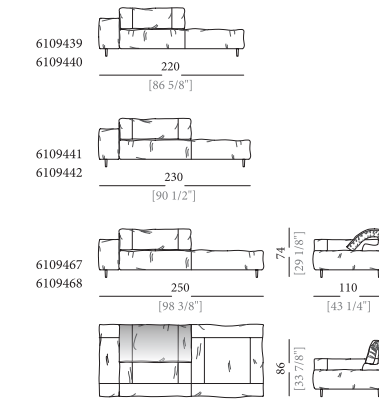

## Right or left corner unit Laterale angolare dx o sx

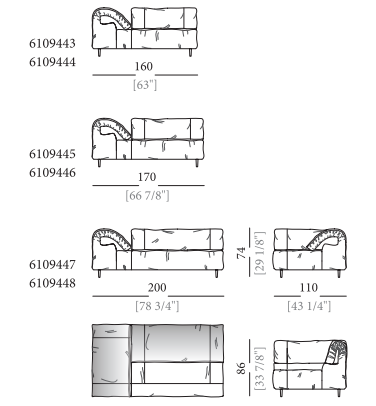



Right or left corner unit  
Laterale angolare dx o sx

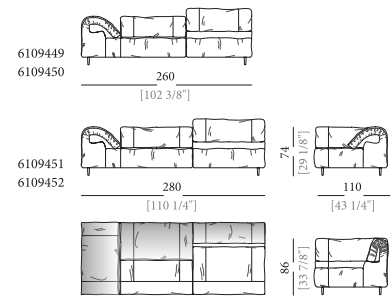

Corner unit with right or left pouf  
Laterale angolare con pouf dx o sx

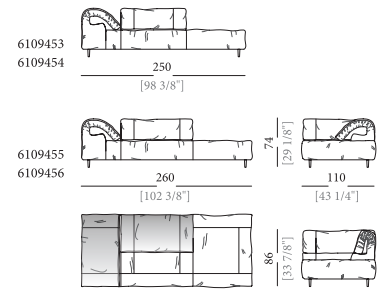

Central unit  
Centrale

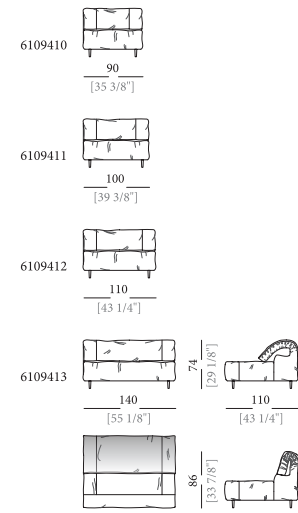

Central unit  
Centrale

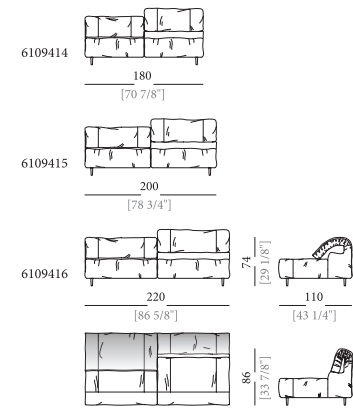

Central unit with right or left pouf  
Centrale con pouf dx o sx

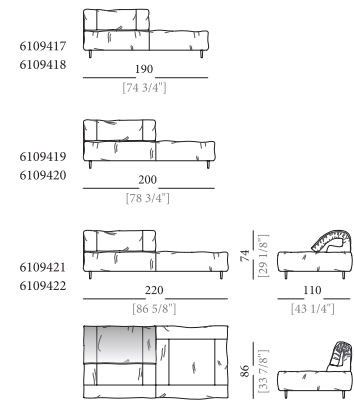

Chaise-longue with right or left short arm  
Chaise longue dx o sx

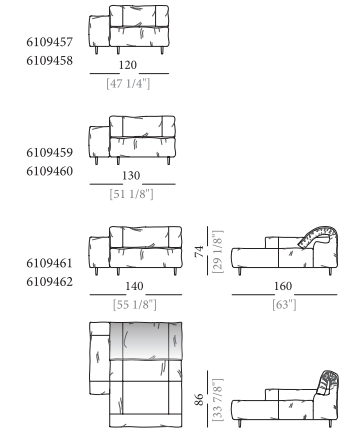

Dormeuse  
Dormeuse

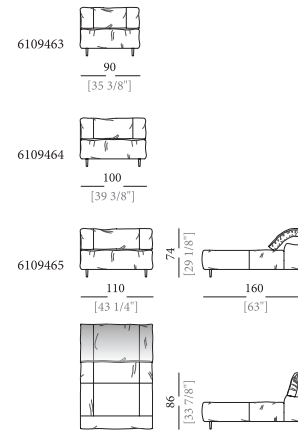

Pouf  
Pouf

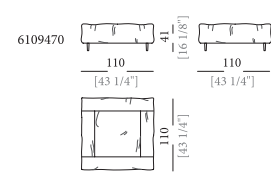

Composition E  
Composizione E

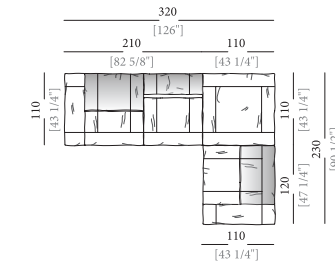

Composition F  
Composizione F

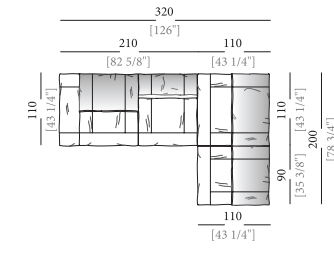

Composition G  
Composizione G

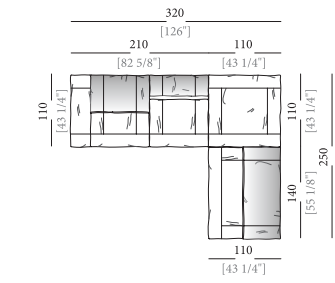

Composition H  
Composizione H

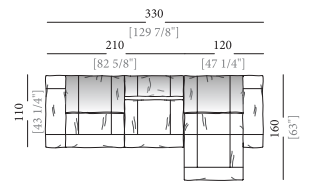

Composition I  
Composizione I

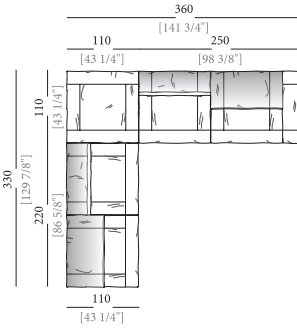

Composition L  
Composizione L



Composition M  
Composizione M

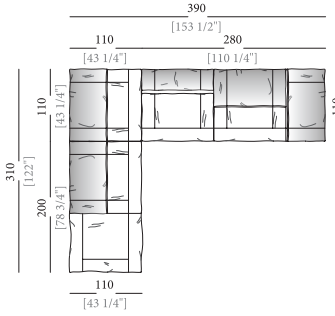

Composition N  
Composizione N

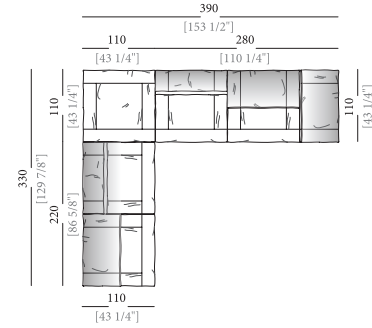

Composition O  
Composizione O

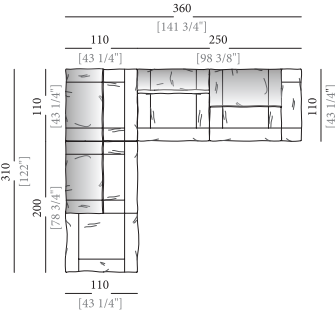

Composition P  
Composizione P





design  
Manzoni & Tapinassi 2011

**Structure** metal and multilayered wood **Frame padding** non-deformable polyurethane of varied densities (30GRF; 25FEE; 35EM and 65) covered with synthetic lining 200 gr and 150 gr which adds softness to the frame **Seat cushions padding** polyurethane of varied densities (HR30/35; soff35S) covered with cotton cover **Back cushions padding** quilted cover, outer side in 100% white Gabardine cotton cover, inner side in cotton/polyester mixed fabric, filling with 50% goose down and 50% "Fiber Ball" (polyester fibre) **Arm padding** quilted cover, outer side in 100% white Gabardine cotton cover, inner side in cotton/polyester mixed fabric, filling in virgin goose down, inner core in expanded polyurethane (D21) **Springing** elastic belts **Seat height** 40 cm **Arm height** 55 cm **Feet** chromed metal, micaceous brown stained metal or black nickel, h. 15 cm

**Struttura** metallo e legno multistrato **Imbottitura fusto** poliuretano indeformabile di varie densità (30GRF; 25FEE; 35EM e 65) rivestito con Tomana 200 gr e 150 gr (per conferire maggiore morbidezza e sofficià alla struttura) **Imbottitura cuscini seduta** poliuretano di varie densità (HR30/35; soff35S) rivestito con fodera in cotone **Imbottitura cuscini schienale** tessuto esterno in Gabardine 100% cotone; tessuto interno in cotone e poliestere; riempitura in 50% piuma d'oca e 50% Fiber Ball (fibre di poliestere) **Imbottitura bracciolo** tessuto esterno in Gabardine 100% cotone; tessuto interno in cotone e poliestere; riempitura in piuma d'oca vergine con 7% di piumino; dima interna in poliuretano espanso (D21) **Piano di molleggio** cinghie elastiche **Altezza seduta** 40 cm **Altezza bracciolo** 55 cm **Piedi** metallo cromato, verniciato marrone micaceo o black nickel, h. 15 cm

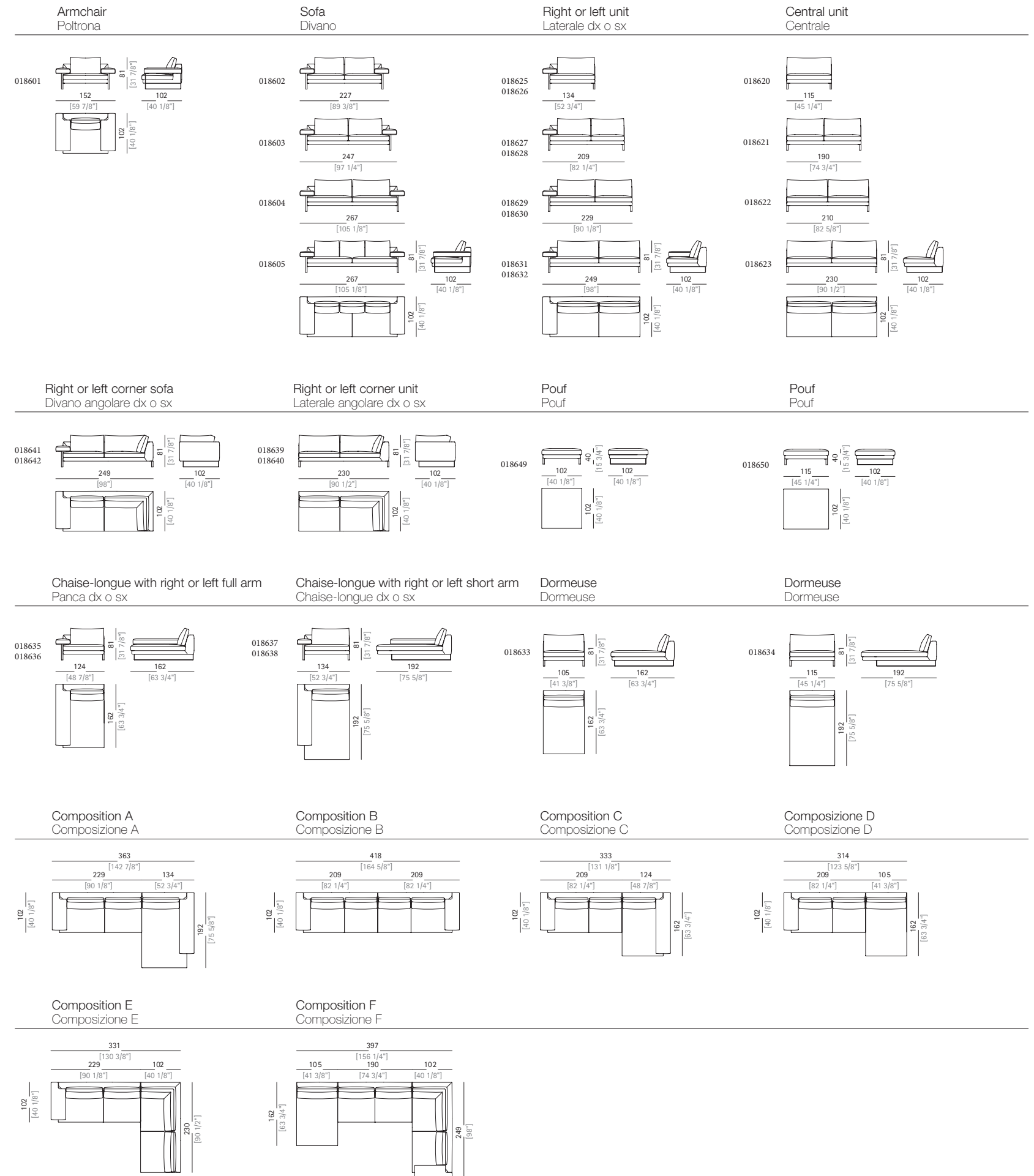

# INKAS



design  
Manzoni & Tapinassi 2011

**Back and seat structure frame** at sight in metal; inner structure in multilayered wood **Arm/back structure padding** 100% down proof twilled cotton cover with thermo bonded Dacron, filled with mixed down, core in polyurethane of varied densities **Seat structure padding** 100% down proof twilled cotton cover filled with mixed down, core in polyurethane (D35 + memory) **Low back cushion padding** 100% Gabardine cotton cover filled with mixed down **Seat height** 40 cm **Arm height** 67 cm **Feet** metal micaceous brown stained, h. 3 cm

**Struttura schienale e seduta** telaio di base in metallo; struttura in legno multistrato **Imbottitura fusto bracciolo/schienale** rivestimento esterno in cotone spigato 100% antipiùma, Dacron termolegato e cotone termosaldato. Riempitura in piumaflex e dima interna in poliuretano a quote differenziate **Imbottitura fusto seduta** rivestimento esterno in cotone spigato 100% antipiùma. Riempitura in piumaflex e dima interna in poliuretano (D35 + memory) **Imbottitura cuscini poggiatesta** tessuto esterno in Gabardine 100% cotone riempitura in piumaflex **Altezza seduta** 40 cm **Altezza bracciolo** 67 cm **Piedi** metallo verniciato colore marrone micaceo, h. 3 cm

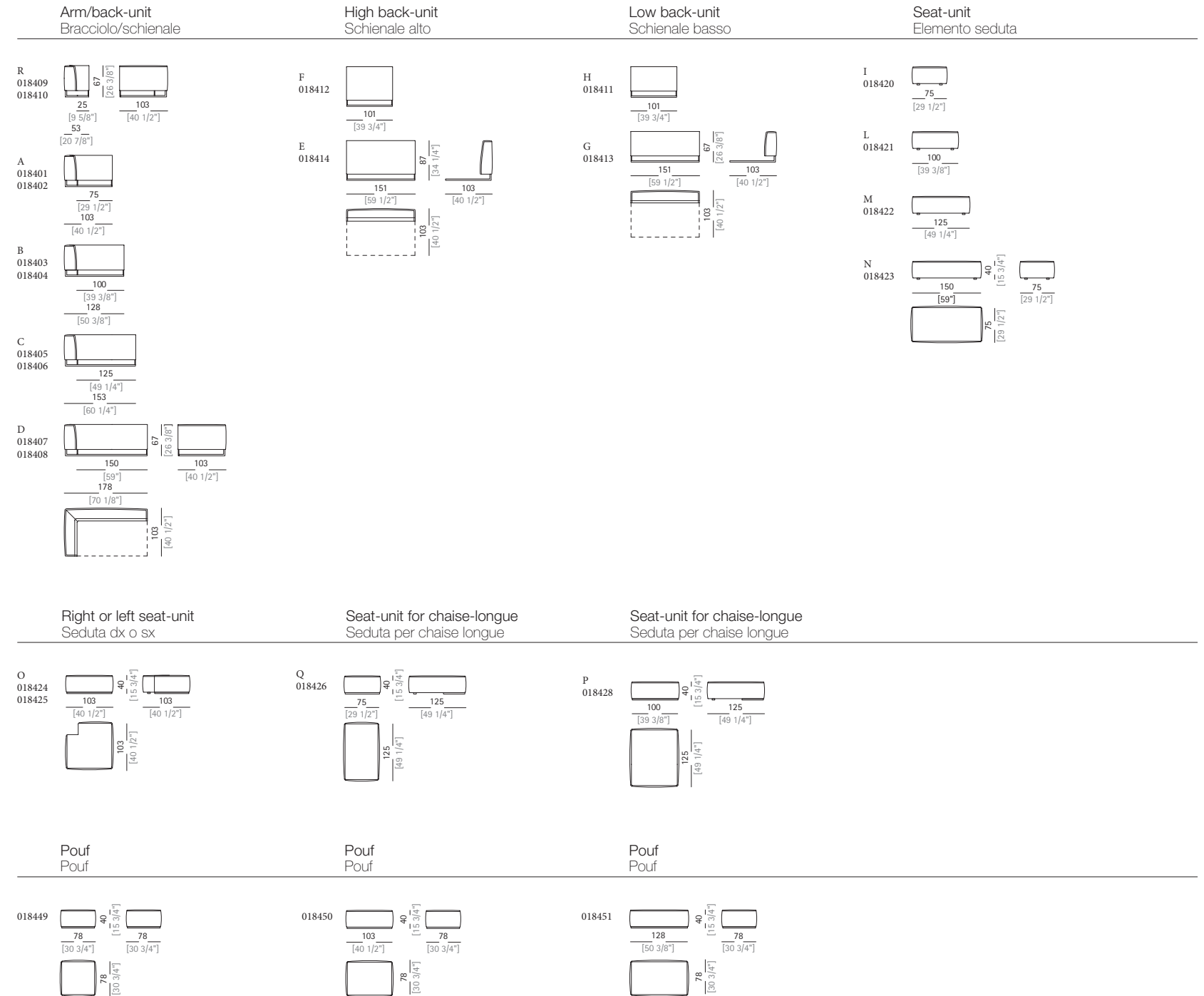

Composition DY  
Composizione DY

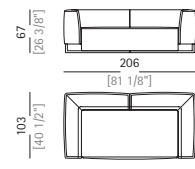

Composition QY  
Composizione QY

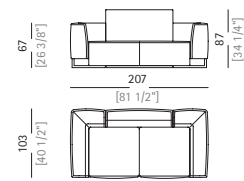

Composition EY  
Composizione EY

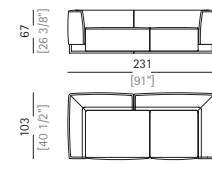

Composition RY  
Composizione RY

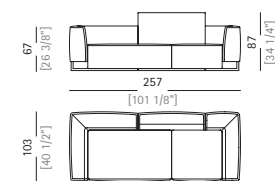

Composition SY  
Composizione SY

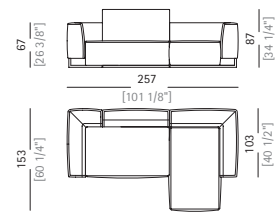

Composition IY  
Composizione IY

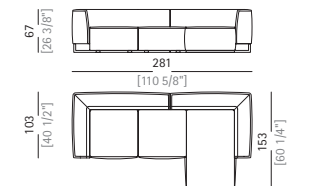

Composition BY  
Composizione BY

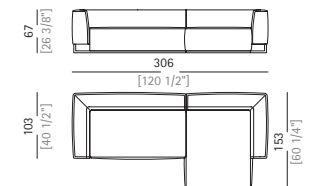

Composition GY  
Composizione GY

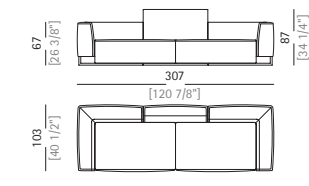

Composition HY  
Composizione HY

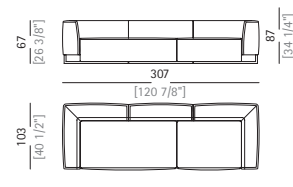

Composition PY  
Composizione PY

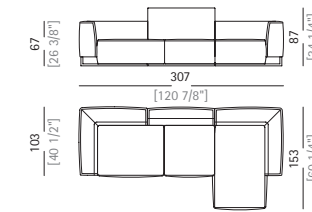

Composition TY  
Composizione TY

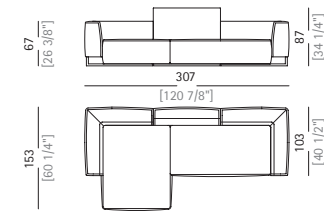

Composition OY  
Composizione OY

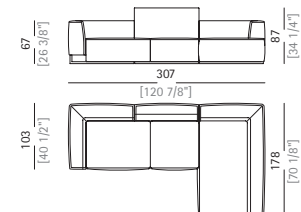

Composition UY  
Composizione UY

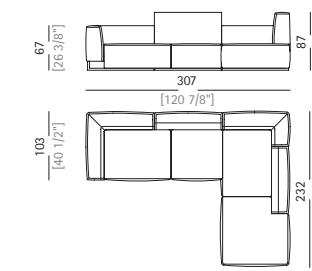

Composition CY  
Composizione CY

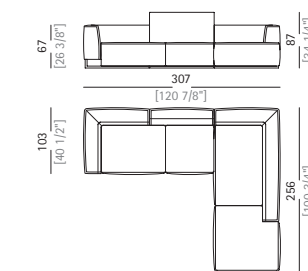

Composition NY  
Composizione NY

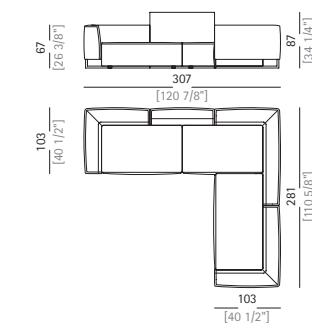

Composition FY  
Composizione FY

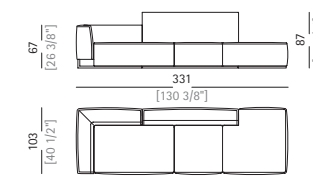

Composition LY  
Composizione LY

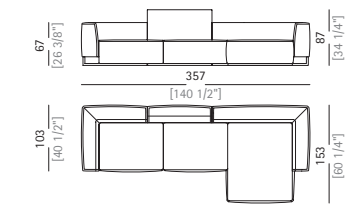

Composition MY  
Composizione MY

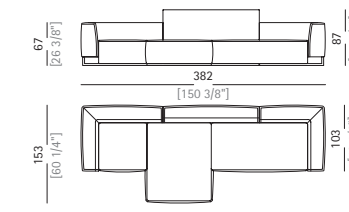

Composition AY  
Composizione AY

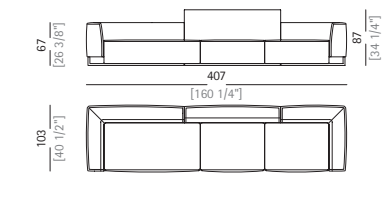

# LOFT



design  
Adriano Piazzi 2003

**Registered model. Structure** varnished metal **Seat padding** non-deformable polyurethane (T35; HR35-36; PK30; HD60) covered by synthetic lining **Arm and back padding** non-deformable polyurethane (PK30) covered by coupled 6mm synthetic lining **Cushions padding** cotton cover filled with mixed down **Springing** elastic belts **Seat height** 36 cm **Arm height** 54 cm **Feet** inox steel, h. 10 cm **Tray** in mat stainless steel with top in polished stainless steel. The sectional units cannot be supplied as single elements. The version "capitonné" (quilted seat cushions) is available only in leather and imitation leather and in this case the covers are not removable. On request the units can be shipped disassembled. The units are supplied with a patented mechanism which enables to adjust the seat depth. Backrest height adjustable. Only the sofas are supplied with split independently-adjustable back, which permits two different seat depths at the same time

**Modello depositato. Struttura** metallo verniciato **Imbottitura seduta** poliuretano indeformabile (T35; HR35-36; PK30; HD60), fodera in tomana **Imbottitura bracciolo e schienale** poliuretano indeformabile (PK30), fodera in accoppiato 6 mm **Spalliera** cotone riempitura fiocco piuma **Piano di molleggio** cinghie elastiche **Altezza seduta** 36 cm **Altezza bracciolo** 54 cm **Piedi** acciaio inox, h. 10 cm **Vassoio** in acciaio inox satinato con piano in acciaio inox lucido.

Gli elementi componibili non si possono realizzare a solo. La versione "capitonné" è disponibile solo in pelle ed ecopelle e non è sfoderabile. Su richiesta gli elementi possono essere inviati smontati. Gli elementi sono forniti di un meccanismo brevettato che permette di modificare la profondità di seduta. Lo schienale è regolabile in altezza. Solo i divani hanno il doppio movimento che consente di avere contemporaneamente due profondità di seduta

Sofa with split independently-adjustable back  
Divano con doppio movimento

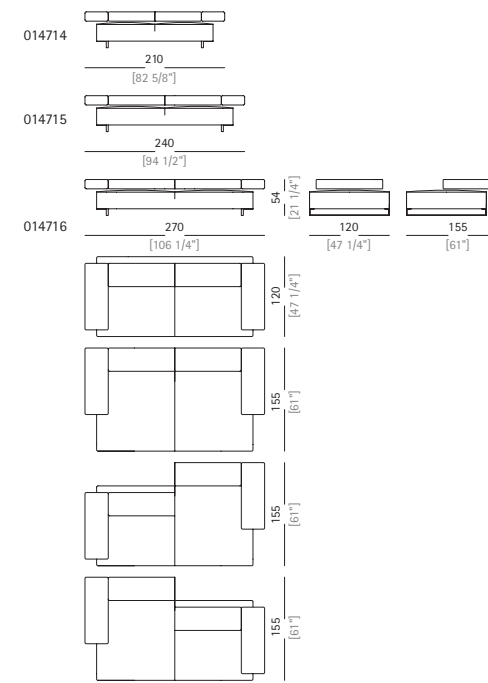

Right or left unit  
Laterale dx o sx

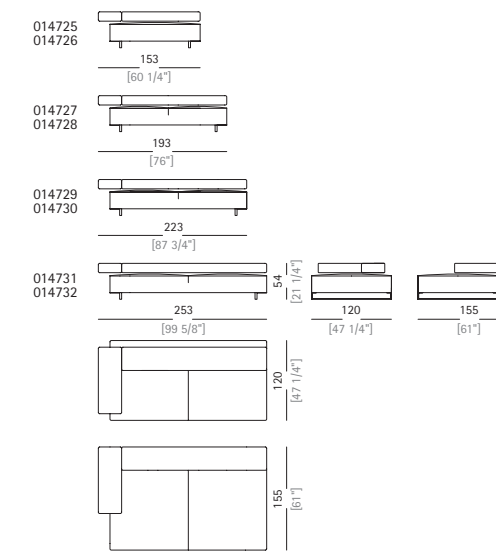

Chaise-longue with right or left short arm  
Chaise longue dx o sx

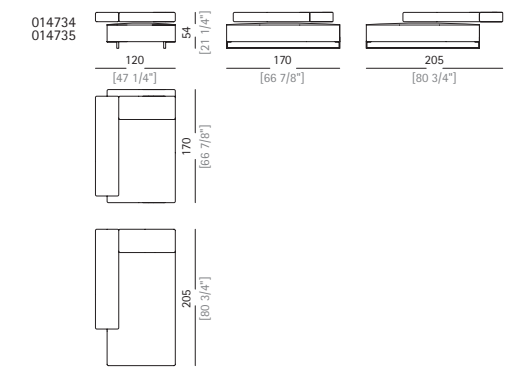

Armchair  
Poltrona

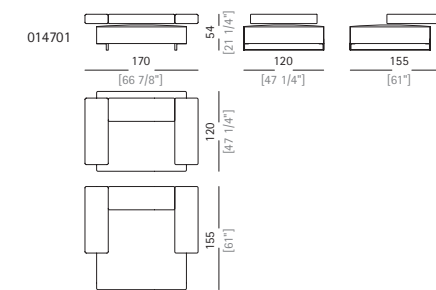

Corner pouf  
Pouf angolare

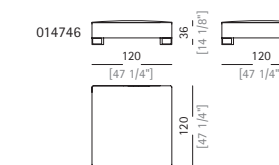

Pouf  
Pouf

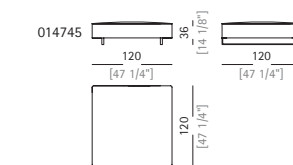

Pouf  
Pouf

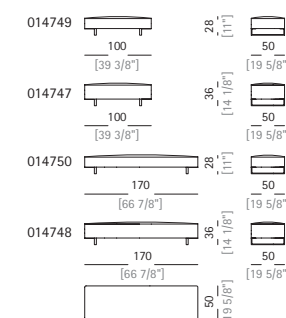

Composition A  
Composizione A

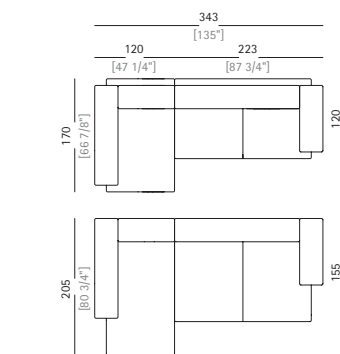

Composition B  
Composizione B

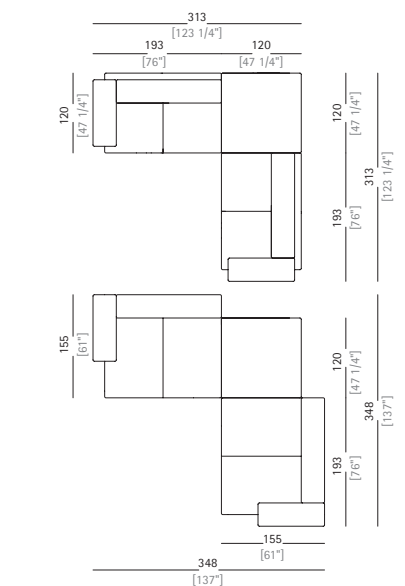

# LOTUS



design  
Manzoni & Tapinassi 2014

**Structure** wood **Padding** expanded polyurethane of varied densities (D18+D30); seat padding in expanded polyurethane D35 and memory foam. Outer cover in 100% down proof twilled cotton filled with mixed down **Springing** elastic belts **Seat height** 44 cm **Arm height** 70 cm **Frame (only for lateral units and sofas)** metal, micaceous brown stained or titanium **Feet** plastic, h. 4 cm

**Struttura** legno **Imbottitura** poliuretano espanso a quote differenziate D18+D30; nella seduta poliuretano espanso D35 e memory foam. Rivestimento in cotone spigato 100% antipiuma bianco riempito in piumaflex **Piano di molleggio** cinghie elastiche **Altezza seduta** 44 cm **Altezza bracciolo** 70 cm **Fascia (solo per elementi laterali e divani)** metallo verniciato marrone micaceo o titanio **Piedi** plastica, h. 4 cm

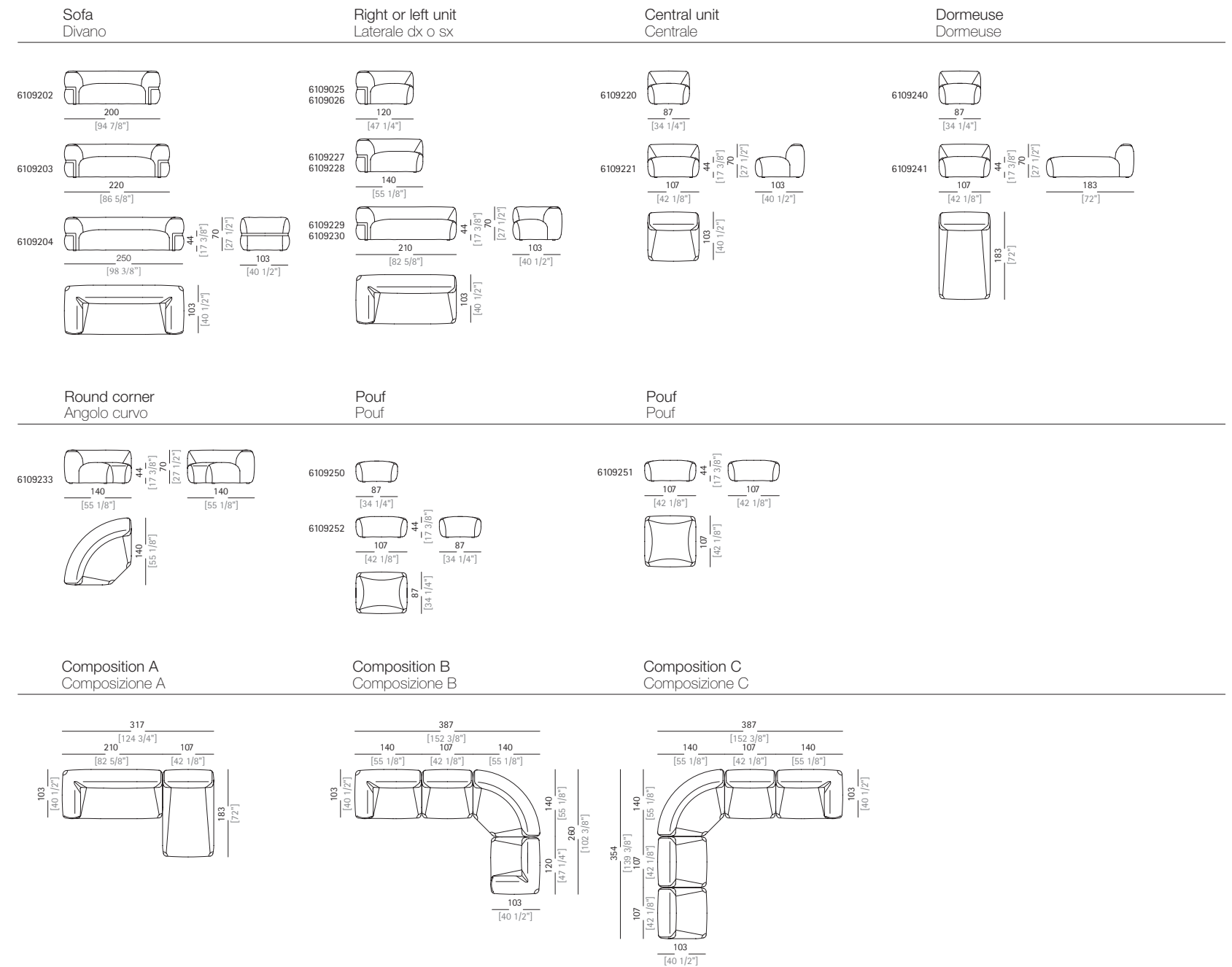

# MALTA



design  
Gordon Guillaumier 2010

**Structure** wood **Frame upholstery** non-deformable polyurethane 30GRF, 21NF, 25F covered with synthetic lining 150 gr. which adds softness to the frame **Seat cushions upholstery** quilted 100% downproof cotton cover filled with goose down and resin foam template D30 or non-deformable polyurethane D30 HR3536 covered with Tecnoform Hjet 280 gr/mq **Back cushions upholstery** quilted 100% downproof cotton cover filled with mixed down **Springing** elastic belts **Seat height** 45 cm **Arm height** 54 cm **Feet** polished or micaceous brown aluminium, h. 8 cm

**Struttura** legno **Imbottitura fusto** poliuretano indeformabile 30GRF, 21NF, 25F rivestito con Tomana 150 gr per conferire maggiore morbidezza e soffici ta alla struttura **Imbottitura cuscini seduta** riempitura in piuma d'oca con dima interna in resina espansa D30 tessuto interno ed esterno in cotone 100% antipiume trapuntato oppure in poliuretano indeformabile D30 HR3536, rivestimento Tecnoform Hjet 280 gr/mq **Imbottitura cuscini schienale** tessuto interno ed esterno in cotone 100% antipiume trapuntato; riempitura in rombo piuma **Piano di molleggio** cinghie elastiche **Altezza seduta** 45 cm **Altezza bracciolo** 54 cm **Piedi** alluminio pressofuso lucido o marrone micaceo, h. 8 cm

Armchair Poltrona	Sofa Divano	Right or left unit Laterale dx o sx	Chaise-longue with right or left short arm Chaise longue dx o sx
017601  017611 	017602  017603  017605  017604 	017627 017628  017629 017630  017631 017632 	017634 017635  017636 017637 
Pouf Pouf	Pouf Pouf	Pouf Pouf	Pouf Pouf
017648 	017649 	017650 	017651 
Composition A Composizione A	Composition B Composizione B	Composition C Composizione C	

# MAREA



design  
Gordon Guillaumier 2008

**Structure** wood **Frame upholstery** non-deformable polyurethane D35IP + D30GRF + D25F covered with Dacron Dupont tex elastic 808/SB/C, which adds softness to the frame **Seat cushions upholstery** quilted 100% cotton cover filled with goose down and resin foam template (D35) with the upper rounded side in memory foam or polyurethane foam D30 + HR3536 covered with cotton fabric coupled with wadding 350gr **Back cushions upholstery** quilted 100% cotton cover filled with goose down and resin foam template D18SS **Springing** elastic belts **Seat height** 39 cm **Arm height** 62 cm **Feet** plastic, h. 4 cm

**Struttura** legno **Imbottitura fusto** poliuretano indeformabile D35IP + D30GRF + D25F rivestito con Dacron Dupont tex elastic 808/SB/C, per conferire morbidezza e soffici ta alla struttura **Imbottitura cuscini seduta** tessuto interno ed esterno in cotone 100% trapuntato; riempitura in piuma con dima interna in resina espansa (D35) e bombatura in memory foam oppure poliuretano indeformabile D30 + HR3536 ricoperto con accoppiato ovatta/cotone da 350gr **Imbottitura cuscini schienale** tessuto esterno in cotone 100% trapuntato; riempitura in piuma con dima interna in resina espansa D18SS **Piano di molleggio** cinghie elastiche **Altezza seduta** 39 cm **Altezza bracciolo** 62 cm **Piedi** plastica, h. 4 cm

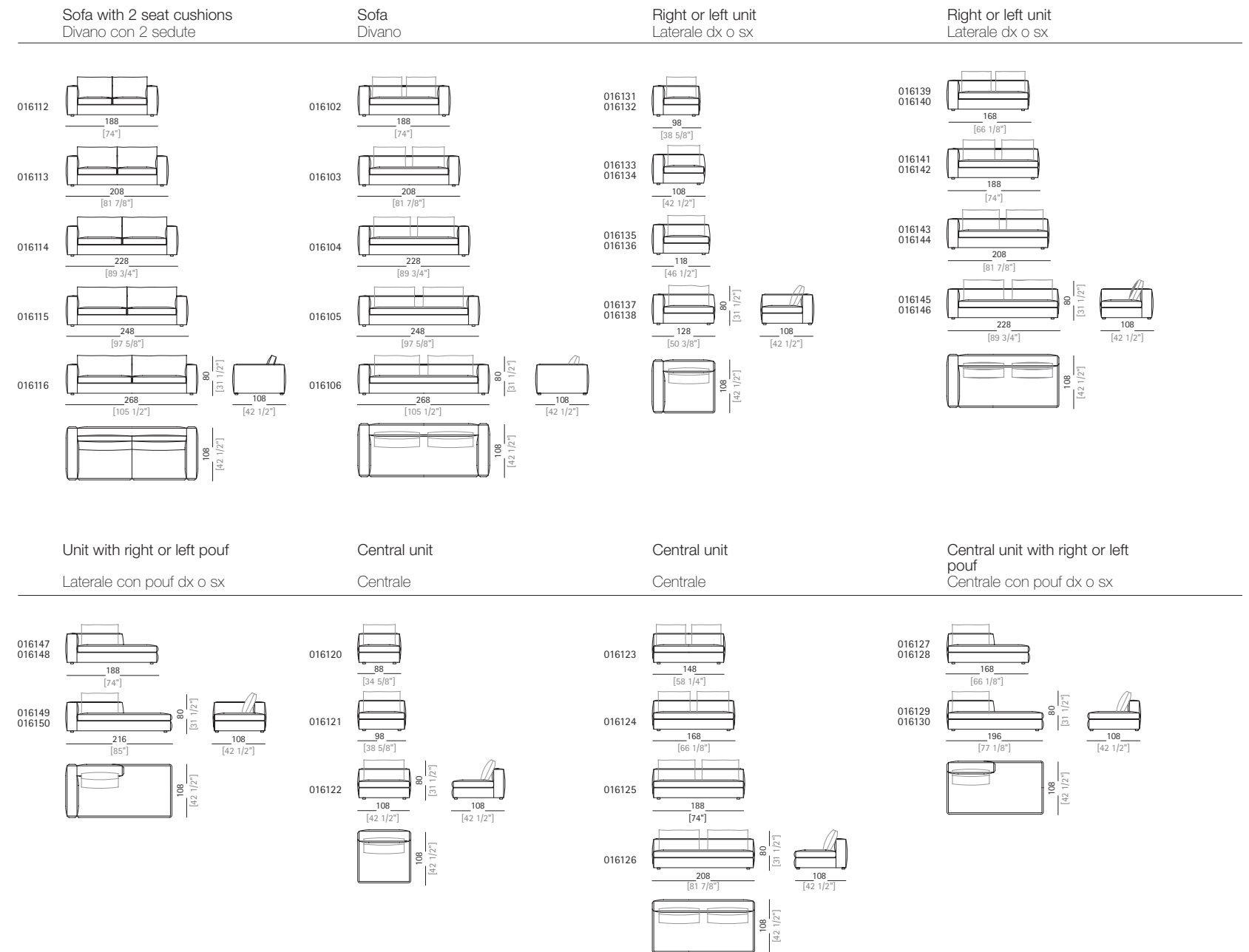



Dormeuse  
Dormeuse

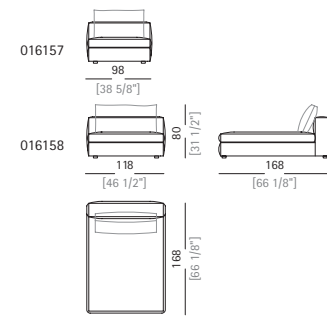

Chaise longue with right or left full arm  
Panca dx o sx

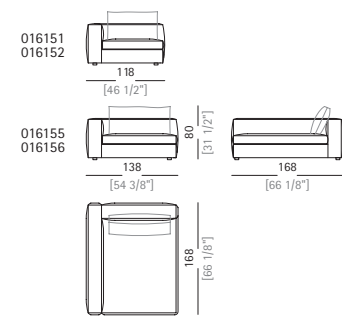

Chaise longue with right or left full arm  
Panca dx o sx

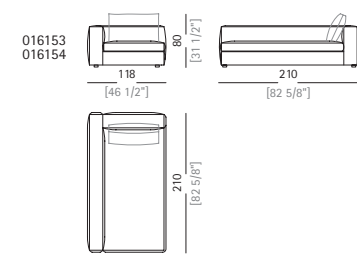

Pouf  
Pouf

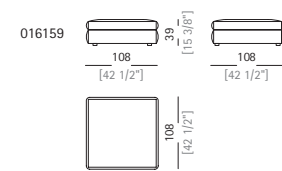

Pouf  
Pouf

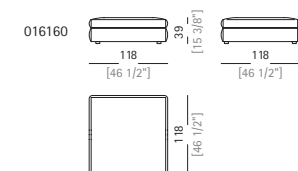

Pouf  
Pouf

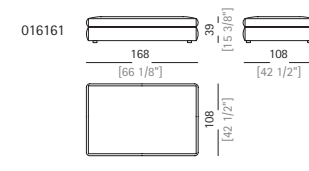

Composition C  
Composizione C

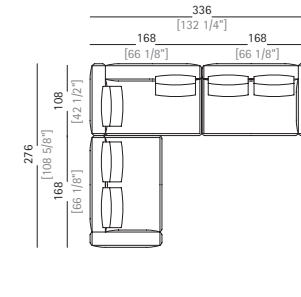

Composition H  
Composizione H

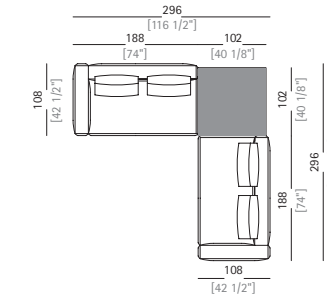

Composition I  
Composizione I

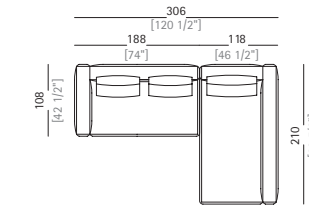

Composition L  
Composizione L

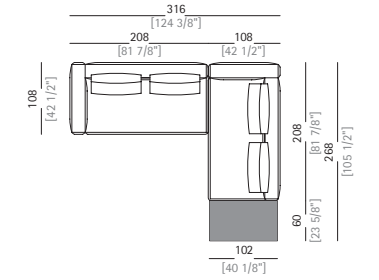

Composition O  
Composizione O

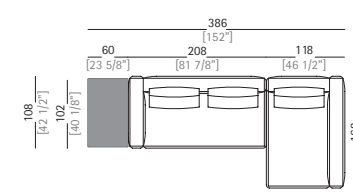

Composition P  
Composizione P

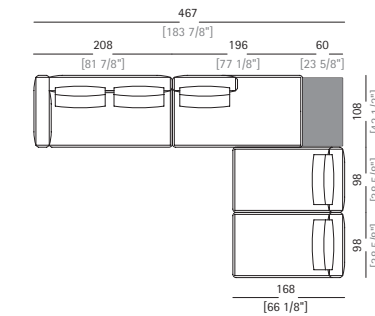

Composition R  
Composizione R

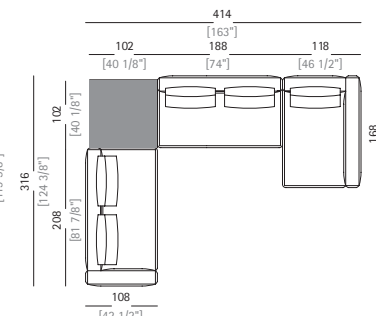

Composition T  
Composizione T

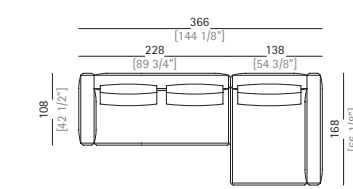

Composition Z  
Composizione Z

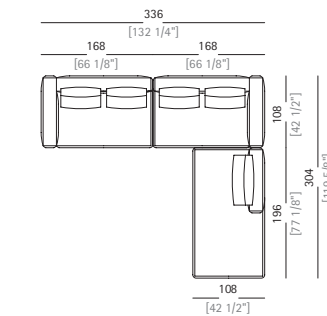

Composition J  
Composizione J

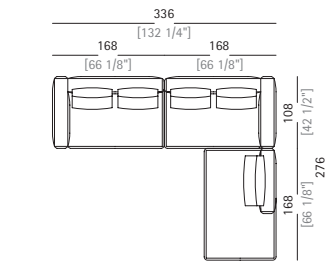

# MORRISON



design  
Mauro Lipparini 2015

**Structure** metal **Structure upholstery** expanded polyurethane D60 covered with coupled synthetic lining 3mm **Seat upholstery** polyurethane of varied densities (D35 elastic + D35 soft); outer cover in 100% downproof white cotton filled with goose down and polyester fibre **Back and arm upholstery** 100% downproof quilted cotton cover filled with goose down and polyester fibre **Springing** elastic belts **Seat height** 42 cm **Arm height** 66 cm **Feet** M1 metal, finishes micaceous brown or titanium, h.16 cm. M2 metal, finishes micaceous brown or titanium, h.16 cm **Piping** available in the following colours white (100), cream white (101), mustard (102), beige (103), green (104), brown (105), dark brown (106), burgundy (107), purple (108), light grey (109), dark grey (110), sand beige (111), olive grey (112), slate grey (113), light blue grey (114) and aquamarine blue (115)

**Struttura** metallo **Imbottitura struttura** poliuretano espanso D60 portante rivestito con vellutino accoppiato spessore 3mm **Imbottitura seduta** imbottitura in poliuretano di varie densità (D35 elastico + D35 soffice). Rivestimento in cotone 100% antipiùma bianco riempito di piuma d'oca e fibra poliestere **Imbottitura schienale e bracciolo** trapunta di cotone 100% antipiùma riempita di piuma d'oca e fibra poliestere **Piano di molleggio** cinghie elastiche **Altezza seduta** 42 cm **Altezza bracciolo** 66 cm **Piedi** M1 in metallo, finiture marrone micaceo o titanio, h.16 cm. M2 in metallo, finiture marrone micaceo o titanio, h.16 cm **Bordino** disponibile nei colori bianco (100), crema (101), senape (102), beige (103), verde (104), marrone (105), testa di moro (106), bordeaux (107), viola (108), grigio chiaro (109), grigio scuro (110), sabbia (111), grigio oliva (112), grigio ardesia (113), grigio azzurro (114) e acqua marina (115)

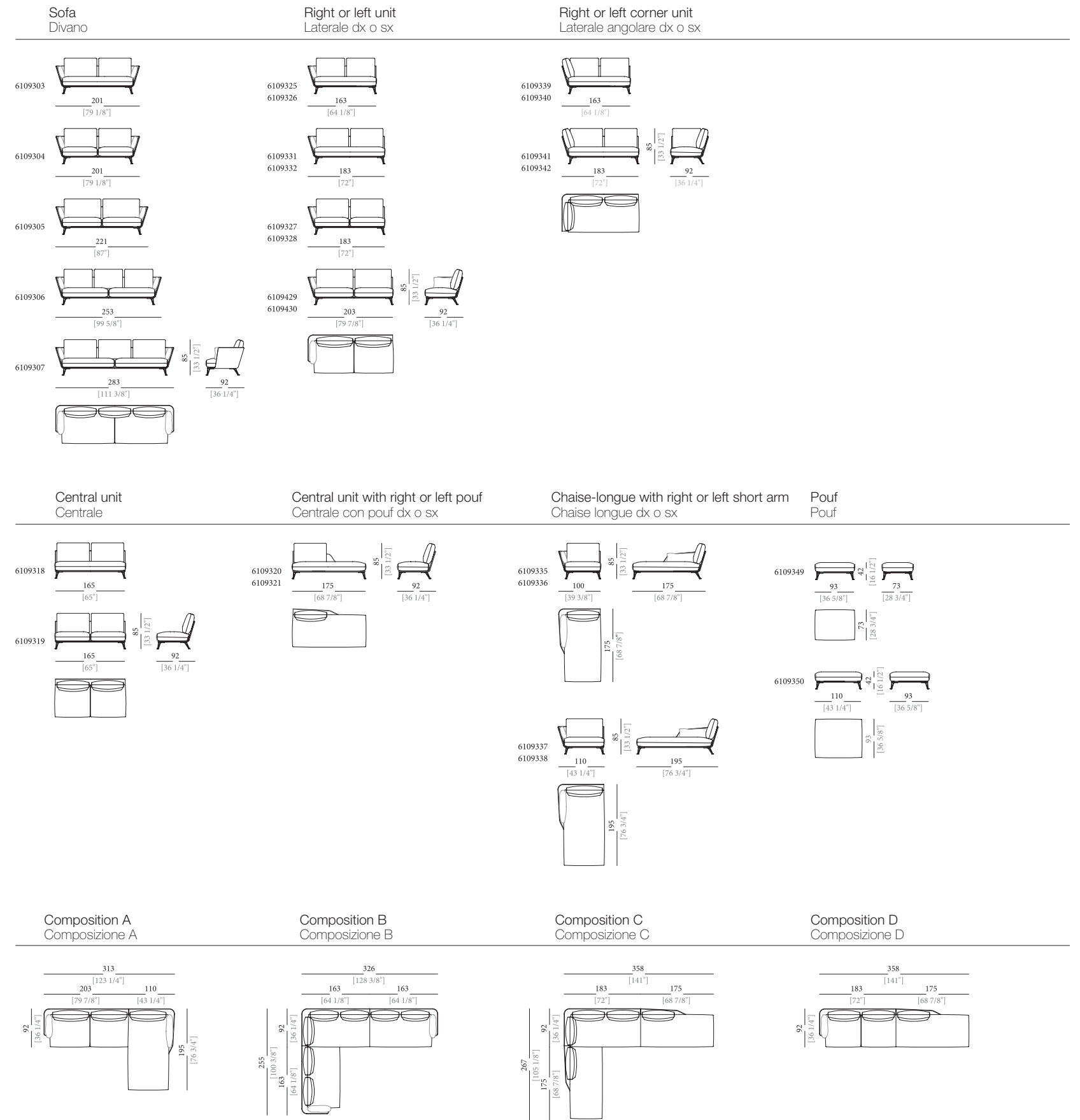



design  
Giuseppe Viganò 2016

**Structure wood Structure upholstery (base, back and arms)** expanded polyurethane of varied densities (D30 highly resilient + D32 elastic and non-deformable + D30 elastic) covered with synthetic lining 6mm and cotton fabric coupled with wadding 380 gr (Cothem) **Seat cushion upholstery** expanded polyurethane of varied densities (D35 elastic and non-deformable) covered with thermo bonded quilted cotton cover coupled with wadding 350gr **Back cushion upholstery** 100% white twilled cotton cover, filling in 50% goose down and 50% "Fiber Ball" (polyester fibres) **Springing** elastic belts **Seat height** 40 cm **Arm height** 62 cm **Feet** metal, finishes: micaceous brown, oxy grey or black nickel, h.15 cm **Piping** available in the following colours: white (100), cream white (101), mustard (102), beige (103), green (104), brown (105), dark brown (106), burgundy (107), purple (108), light grey (109), dark grey (110), sand beige (111), olive grey (112), slate grey (113), light blue grey (114) and aquamarine blue (115)

**Struttura legno Imbottitura struttura (base, schienale e braccioli)** poliuretano espanso a quote differenziate (D30 graffiato e ad alta portanza + D32 elastico e indeformabile + D30 elastico), rivestito con accoppiato 6mm gomma e trit e ovatta accoppiata con cotone (Cothem) 380gr. **Imbottitura cuscino seduta** poliuretano espanso a quote differenziate (D35 elastico ed indeformabile), rivestito da una trapunta ovatta termosaldata 350gr con una fordera di cotone **Imbottitura cuscini schienale** tessuto esterno in 100% cotone spigato bianco; riempitura in 50% di piuma d'oca e 50% "Fiber Ball" (fibre di poliestere) **Piano di molleggio** cinghie elastiche **Altezza seduta** 40 cm **Altezza bracciolo** 62 cm **Piedi** metallo, finiture: marrone micaceo, oxy grey o black nickel h.15 cm **Bordino** disponibile nei colori: bianco (100), crema (101), senape (102), beige (103), verde (104), marrone (105), testa di moro (106), bordeaux (107), viola (108), grigio chiaro (109), grigio scuro (110), sabbia (111), grigio oliva (112), grigio ardesia (113), grigio azzurro (114) e acqua marina (115)

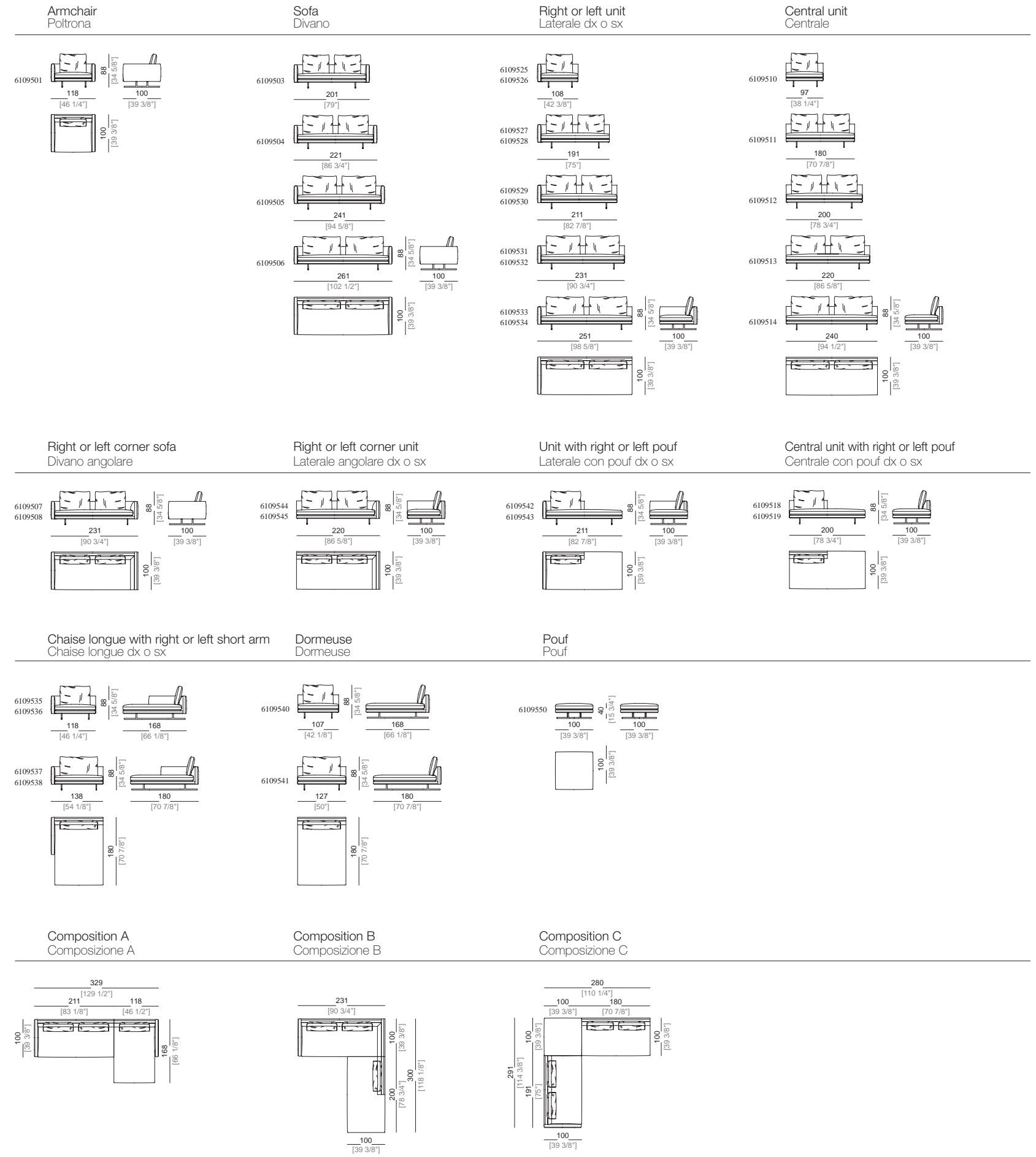

# PLAT



design  
Manzoni & Tapinassi 2004

**Structure** varnished metal **Frame padding** non-deformable polyurethane D32PH + D30, covered with synthetic lining **Back padding** cotton cover filled with goose down, with resin foam template D18 **Seat padding** quilted cotton cover filled with goose down and resin foam template (D35) with the upper rounded side in memory foam **Springing** electric-welded net **Seat height** 37 cm **Arm height** 50 cm **Feet** plastic h. 5,5 cm. The height of the foot can be made 8 cm on request, without extra charge **Accessories** bookshelves and trays in tempered glass or stainless steel or reconstituted ebony, polyester glossy lacquer

**Struttura** metallo verniciato **Imbottitura fusto** poliuretano indeformabile D32PH + D30 ricoperto di tomana **Imbottitura cuscini schienale** cotone riempitura piuma d'oca con dima resina espansa D18 **Imbottitura cuscini seduta** cotone trapuntato riempitura piuma d'oca con dima resina espansa (D35) e bombatura in memory foam **Piano di molleggio** rete elettrosaldata **Altezza seduta** 37 cm **Altezza bracciolo** 50 cm **Piedi** plastica h. 5,5 cm. Su richiesta il piede può essere fornito in altezza 8 cm senza supplemento **Optional** librerie e vassoi in vetro temperato o acciaio inox o ebano precomposto laccato poliestere lucido

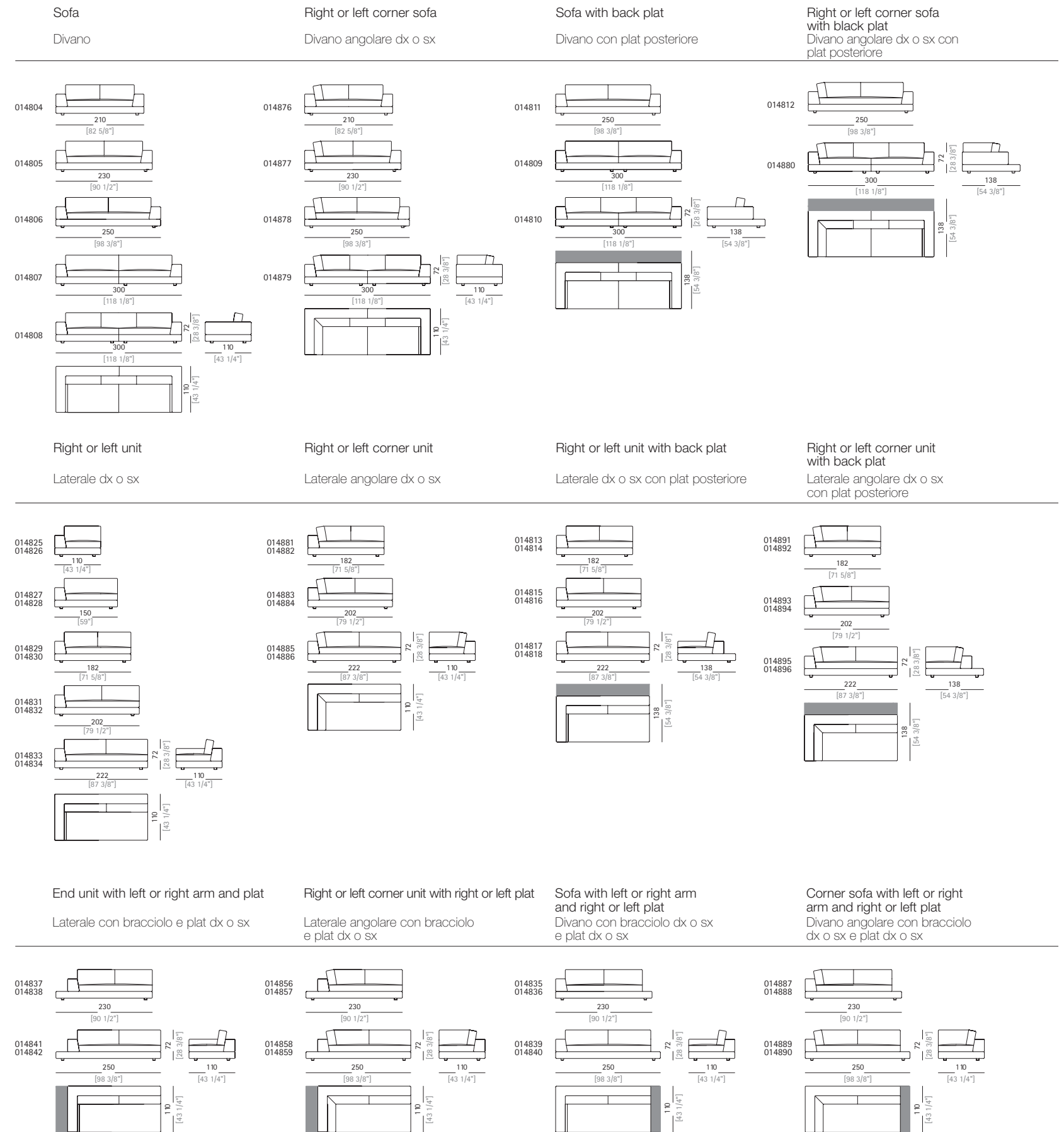

Central unit  
Centrale

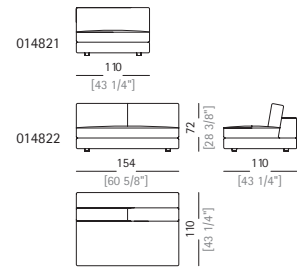

Central unit with back plat  
Centrale con plat posteriore

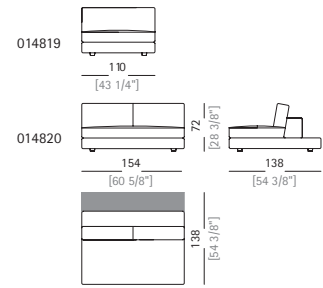

Square corner  
Angolare quadro

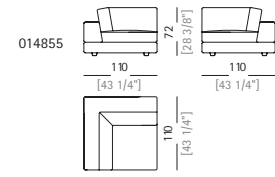

Relax unit type A with right or left arm  
Relax A con bracciolo dx o sx

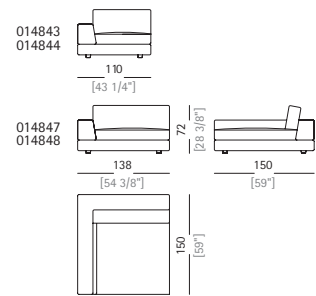

Relax unit type B with right or left plat  
Relax B con plat dx o sx

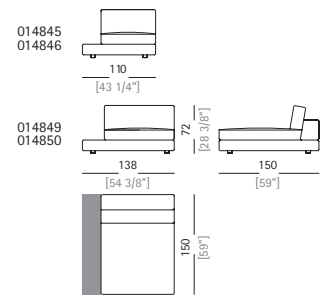

Relax unit type C with right or left full arm and right or left plat  
Relax C con bracciolo lungo e plat dx o sx

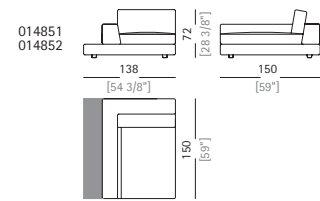

Relax unit type D with right or left short arm and right or left plat  
Relax D con bracciolo corto e plat dx o sx

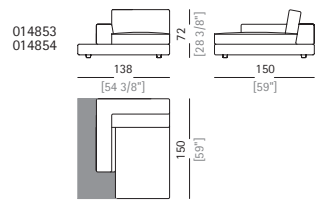

Relax unit type A with right or left arm and back plat  
Relax A con bracciolo dx o sx e plat posteriore

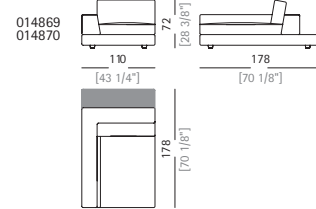

Relax unit type B with right or left plat and back plat  
Relax B con plat dx o sx e plat posteriore

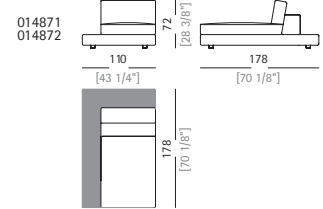

Pouf with side plat  
Pouf con plat laterale

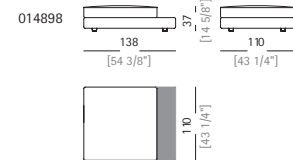

Pouf with corner plat  
Pouf con plat angolare

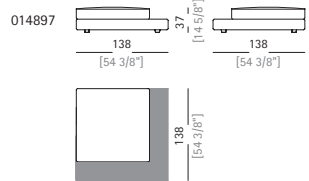

Pouf  
Pouf

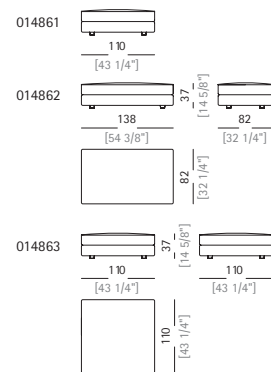

Plat  
Plat

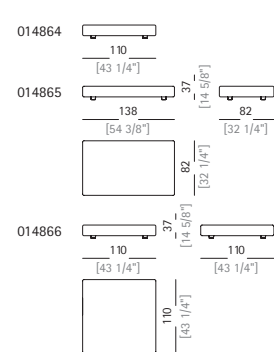

Tray  
Vassoio

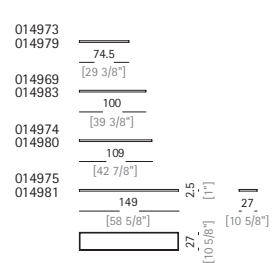

Bookshelf  
Libreria

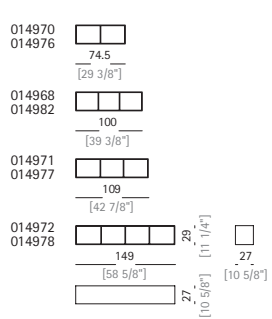

Composition C  
Composizione C

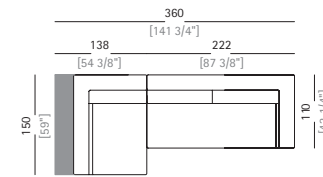

Composition D  
Composizione D

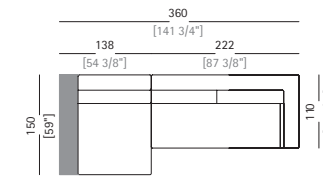

Composition H  
Composizione H

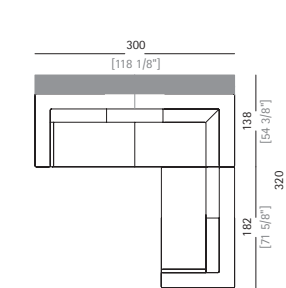

Composition I  
Composizione I

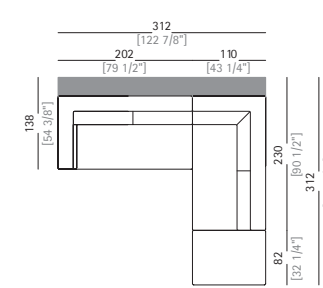

Composition N  
Composizione N

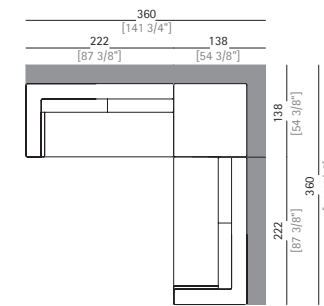

Composition P  
Composizione P

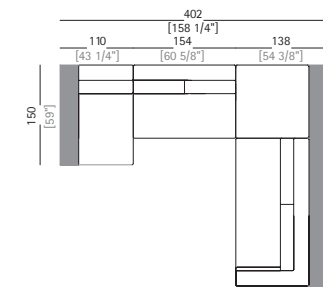

Composition Q  
Composizione Q

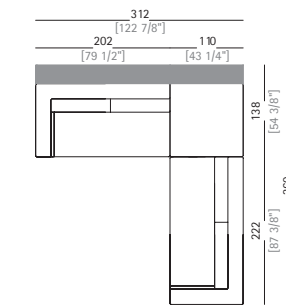

Composition R  
Composizione R

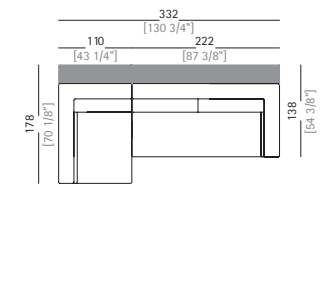

Composition S  
Composizione S

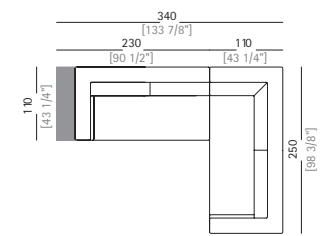

Composition T  
Composizione T

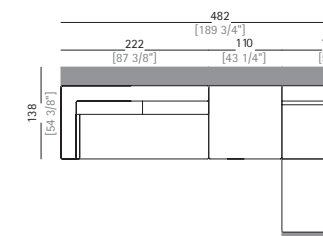

Composition U  
Composizione U

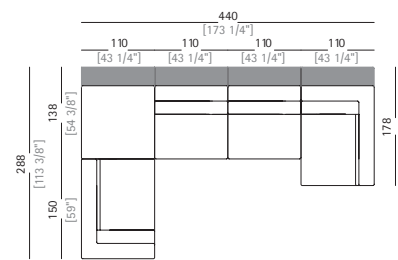

# RAIL



design  
Manzoni & Tapinassi 2011

**Structure** wood **Frame padding** non-deformable polyurethane of varied densities (30GRF; 30EM and 65) covered with coupled synthetic lining 10 mm **Seat cushion padding** polyurethane of varied densities (HR30/35); under side covered with polyester/cotton mixed fabric, upper side covered with 100% cotton fabric coupled with wadding 350 gr **Back cushion padding** quilted cover, outer side in white 100% Gabardine cotton cover, inner side in polyester/cotton mixed fabric filled with Rombo\_fe (down and polyurethane chips) **Springing** elastic belts **Seat height** 40 cm **Arm height** 64 cm **Feet** chromed metal or micaceous brown stained metal, h. 18 cm. The perimeters of the base and of the arm/backrest are outlined with double stitching. In the case of thicker fabrics, there will be a single line of stitching

**Struttura** legno **Imbottitura fusto** poliuretano indeformabile di varie densità (30GRF; 30EM e 65) rivestito con fodera di vellutino accoppiato 10 mm **Imbottitura cuscini seduta** poliuretano di varie densità (HR30/35) rivestito inferiormente in tessuto poliestere/cotone e superiormente in accoppiato in cotone 100% con ovatta 350 gr **Imbottitura cuscini schienale** rivestimento esterno in gabardine 30/20 bianco in cotone 100% e rivestimento interno in poliestere e cotone; riempitura in Rombo\_fe (miscela di piuma d'oca e trucioli di poliuretano) **Piano di molleggio** cinghie elastiche **Altezza seduta** 40 cm **Altezza bracciolo** 64 cm **Piedi** metallo cromato o verniciato marrone micaceo, h. 18 cm. Il perimetro della base e del bracciolo/schienale è marcato da una doppia cucitura; per tessuti di grosso spessore la cucitura sarà semplice

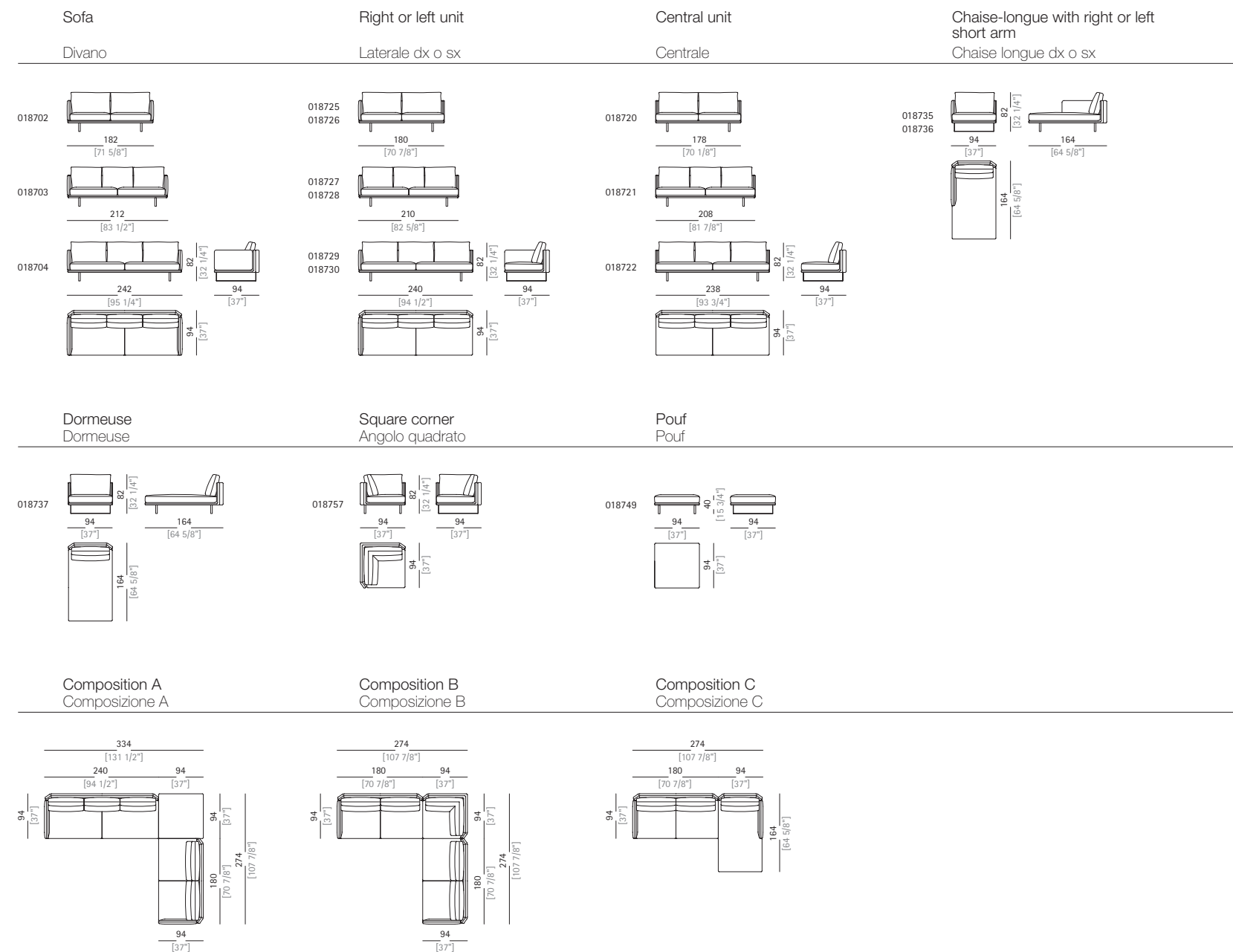

# WINDSOR



design  
Manzoni & Tapinassi 2011

**Structure** wood **Frame padding** non-deformable polyurethane (D30 + D35) covered with Dacron 400 gr **Seat cushion padding** 100% cotton cover filled with down and a resilient inner core D35 **Springing** elastic belts  
**Seat height** 40 cm **Arm - backrest height** 65 cm **Feet** beech wood covered with leather or velvet; underfoot in aluminum; h. 14 cm.  
 The cover is not removable. It is available in velvet (our collection **Vellù** or velvet supplied by the client) or in the following leathers: **Pelle First, Pelle B, Pelle A, Pelle Leonardo**. C.O.L. max thickness 1,3 mm

**Struttura** legno **Imbottitura fusto** poliuretano indeformabile (D30 + D35) rivestito con Dacron 400 gr **Imbottitura cuscini seduta** tessuto interno ed esterno in cotone 100%; riempitura in piuma con dima interna in resina espansa D35 **Piano di molleggio** cinghie elastiche **Altezza seduta** 40 cm **Altezza bracciolo-schienale** 65 cm **Piedi** legno di faggio rivestiti in pelle o in velluto; sottopiede in alluminio; h. 14 cm.  
 Il divano non è sfoderabile. Può essere realizzato in velluto (collezione **Vellù** o velluto fornito dal cliente) o nelle seguenti pelli: **Pelle First, Pelle B, Pelle A, Pelle Leonardo**. Pelle cliente massimo spessore 1,3 mm

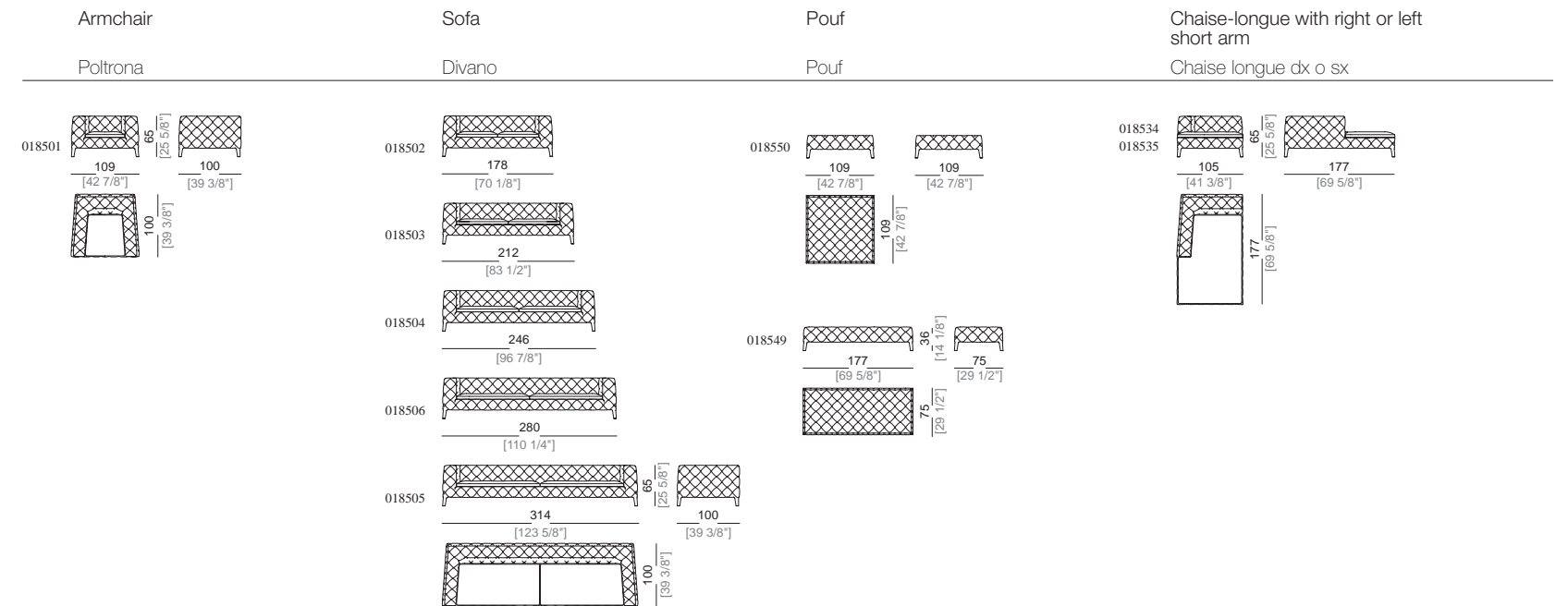

# FLY



design  
Manzoni & Tapinassi 2004

**Structure** metal **Frame padding** cold-expanded polyurethane **Base** metal swivel base in micaceous brown or aluminium colour **Seat height** 37 cm

**Struttura** metallo **Imbottitura fusto** poliuretano schiumato a freddo **Basamento** metallo verniciato marrone micaceo o grigio alluminio **Altezza seduta** 37 cm

Armchair  
Poltrona

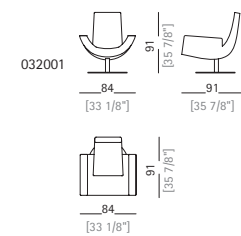

# GIGLIO



design  
Massimo Lorusso 2010

**Structure** wood **Frame upholstery** non-deformable polyurethane D30GRF covered with synthetic lining 150 gr **Seat cushion upholstery** non-deformable polyurethane D35EM covered with synthetic lining 150 gr **Springing** elastic belts **Seat height** 45 cm **Arm height** 68 cm **Feet** polished aluminium, h. 15 cm

**Struttura** legno **Imbottitura fusto** poliuretano indeformabile D30GRF rivestito con tomana 150 gr **Imbottitura seduta** poliuretano indeformabile D35EM rivestito con tomana 150 gr **Piano di molleggio** cinghie elastiche **Altezza seduta** 45 cm **Altezza bracciolo** 68 cm **Piedi** alluminio pressofuso lucido, h. 15 cm

Armchair  
Poltrona

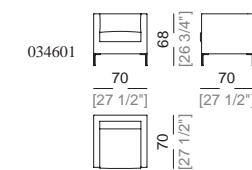



# GOLDFINGER



design  
Marzia & Leonardo Dainelli 2013

**Structure** wood **Frame padding** non deformable polyurethane of varied densities (35 soft + F30 + 75SR) covered with synthetic lining 230 gr and Dacron 300 gr **Seat padding** outer cover in 100% cotton. Filling in polyurethane D35 soft with internal metal springs (h 10cm) covered with Dacron 400 gr and synthetic lining 230 gr **Low back cushion padding** outer side in white Gabardine cotton 21/32 cover, filling in 50% white virgin goose down and 50% memory foam **Springing** springs h 10 cm **Seat height** 43 cm **Arm height** 57 cm **Feet** metal sheet, finishes: micaceous brown, titanium or brass, h 15 cm **Zip** two coloured metal (brass and nickel) **Piping** it is available in fabric, in leather or grosgrain (zip colour chart) in the following colours: white (100), cream white (101), mustard (102), beige (103), green (104), brown (105), dark brown (106), burgundy (107), purple (108), light grey (109), dark grey (110), sand beige (111), olive grey (112), slate grey (113), light blue grey (114) and aquamarine blue (115)

**Struttura** legno **Imbottitura fusto** poliuretano indeformabile di varie densità (35soft + F30 + 75SR) rivestito con Tomana 230 gr e con Dacron 300 gr **Imbottitura seduta** tessuto esterno 100% cotone. Poliuretano D35 soft e molleggio interno con molle in metallo (h 10 cm); rivestimento con Dacron 400 gr e Tomana 230 gr **Imbottitura poggiatesta** tessuto esterno in Gabardina 21/32 bianco, riempitura 50% di piuma d'oca vergine bianca e 50% di "pirulino" di memory foam **Piano di molleggio** molle h 10 cm **Altezza seduta** 43 cm **Altezza bracciolo** 57 cm **Piedi** lamiera di metallo, finiture: marrone micaceo o titanio o ottone, h 15 cm **Cerniera** metallo multicolor colore ottone e nichel **Bordino** può essere realizzato in tessuto, in pelle o in gros-grain (campionario cerniere) nei colori: bianco (100), crema (101), senape (102), beige (103), verde (104), marrone (105), testa di moro (106), bordeaux (107), viola (108), grigio chiaro (109), grigio scuro (110), sabbia (111), grigio oliva (112), grigio ardesia (113), grigio azzurro (114) e acqua marina (115)

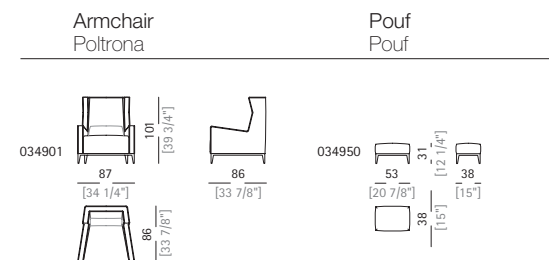

# JUNO



design  
Mauro Lipparini 2015

**Structure** rigid polyurethane foam **Seat upholstery** polyurethane of varied densities (D35 elastic + D35 soft + D35 super soft); outer cover in 100% downproof cotton filled with goose down and polyester fibre **Back and arm upholstery** quilted 100% white downproof cotton cover filled with goose down and polyester fibre; internal core in expanded polyurethane D21 soft **Seat height** 46 cm **Arm height** 60 cm **Feet** metal, finishes micaceous brown or titanium **Attention** The buttons that support the legs are upholstered with the same material as the cushions.

**Struttura** scocca in schiuma di poliuretano rigido **Imbottitura seduta** poliuretano di varie densità (D35 elastico + D35 soffice + D35 super soffice). Rivestimento in cotone 100% antipiùma riempito di piuma d'oca e fibra poliestere **Imbottitura schienale e bracciolo** trapunta di tessuto di cotone 100% antipiùma bianco riempita di piuma d'oca e fibra poliestere, dima interna in poliuretano espanso D21 soffice **Altezza seduta** 46 cm **Altezza bracciolo** 60 cm **Piedi** metallo, finiture marrone micaceo o titanio. **Attenzione** I bottoni di sostegno delle gambe vengono rivestiti con lo stesso materiale della cuscineria.

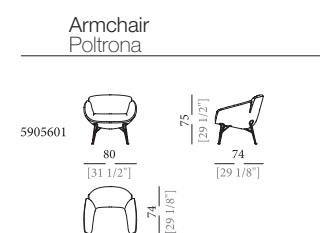

# JUPITER



design  
Mauro Lipparini 2013

**Structure** fiberglass, colour light grey (RAL 7044) or beige grey (RAL 7006) **Seat and arm padding** outer cover in 100% white cotton. Filling in 100% goose down, internal core in expanded polyurethane (PF45) **Back padding** outer cover in 100% white cotton. Filling in 100% goose down, internal core in expanded polyurethane (D21) **Pouf padding** wood panel covered with 100% goose down, core in expanded polyurethane PF45FR and memory foam, covered with 100% white cotton fabric **Seat height** 47 cm **Feet** metal, finishes: micaceous brown, titanium or black nickel  
The characteristics of hand crafted fiberglass are not uniform and this may result in an uneven surface to the structure. Each armchair is numbered and signed as single piece by the designer Mauro Lipparini

**Struttura** vetroresina colore grigio chiaro (RAL 7044) oppure colore grigio beige (RAL 7006) **Imbottitura braccioni e seduta** tessuto esterno bianco 100% cotone. Imbottitura in piuma d'oca 100%, dima interna in poliuretano espanso (PF45) **Imbottitura schienale** tessuto esterno bianco 100% cotone. Imbottitura in piuma d'oca 100%, dima interna in poliuretano espanso (D21) **Imbottitura pouf** pannello in legno imbottito in 100% piuma d'oca, dima interna in poliuretano espanso PF45FR e memory foam, tessuto esterno 100% cotone bianco **Altezza seduta** 47 cm **Piedi** metallo finiture: marrone micaceo, titanio o black nickel  
La caratteristica del vetroresina lavorato artigianalmente è quella di non essere uniforme; pertanto la superficie della struttura può presentare delle irregolarità. Ogni poltrona è numerata come pezzo unico e firmata dal designer Mauro Lipparini

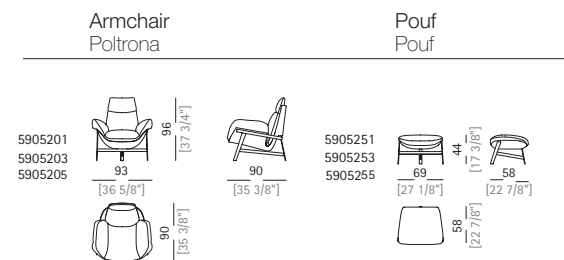

# JUPITER LITE



design  
Mauro Lipparini 2016

**Structure** polyurethane shell, light grey (RAL 7044) or beige grey (RAL 7006) or polyurethane shell covered with leather Pelle Leonardo **Seat and arm padding** outer cover in 100% white cotton. Filling in 100% goose down, internal core in expanded polyurethane (PF45) **Back padding** outer cover in 100% white cotton. Filling in 100% goose down, internal core in expanded polyurethane (D21) **Pouf padding** wood panel covered with 100% goose down, core in expanded polyurethane PF45FR and memory foam, covered with 100% white cotton fabric **Seat height** 47 cm **Feet** metal, finishes: micaceous brown, titanium or black nickel

**Struttura** scocca in poliuretano colore grigio chiaro (RAL 7044) o grigio beige (RAL 7006) oppure scocca in poliuretano rivestita esternamente in Pelle Leonardo **Imbottitura braccioni e seduta** Tessuto esterno bianco 100% cotone. Imbottitura in piuma d'oca 100%, dima interna in poliuretano espanso (PF45) **Imbottitura schienale** tessuto esterno bianco 100% cotone. Imbottitura in piuma d'oca 100%, dima interna in poliuretano espanso (D21) **Imbottitura pouf** pannello in legno imbottito in 100% piuma d'oca, dima interna in poliuretano espanso PF45FR e memory foam, tessuto esterno 100% cotone bianco **Altezza seduta** 47 cm **Piedi** metallo, finiture: marrone micaceo, titanio o black nickel

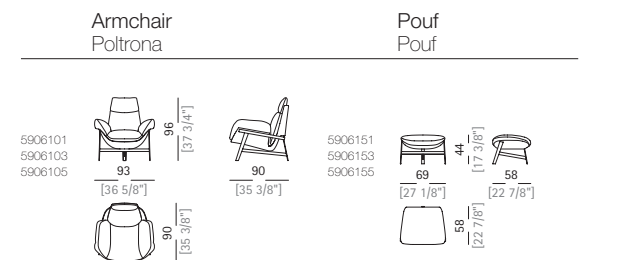

# KONO



design  
Carlo Bimbi 2006

**Structure** varnished metal **Upholstery** cold-expanded polyurethane covered with coupled 6 mm synthetic lining **Springing** elastic belts **Maximum seat height** 44 cm **Base** metal swivel base, varnished in aluminium colour. On request, stitching and zips can be done in a contrast colour.

**Struttura** metallo verniciato **Imbottitura** poliuretano schiumato a freddo rivestito con vellutino accoppiato 6 mm **Piano di molleggio** cinghie elastiche **Altezza massima seduta** 44 cm **Basamento girevole**, in metallo verniciato colore alluminio. Su richiesta le cuciture e le cerniere possono essere eseguite in colore a contrasto.

Armchair  
Poltrona

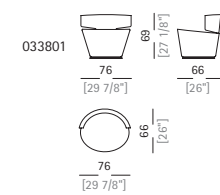

# LOL:)



design  
Giuseppe Viganò 2015

**Structure** wood **Padding** non-deformable polyurethane of varied densities (D35 elastic + D35 soft + D35 super soft for the seat; D21 elastic + D23 super soft for the back). Outer cover in synthetic lining 450gr **Zips** available in the following colours: white (100), cream white (101), mustard (102), beige (103), green (104), brown (105), dark brown (106), burgundy (107), purple (108), light grey (109), dark grey (110), sand beige (111), olive grey (112), slate grey (113), light blue grey (114) and aquamarine blue (115) **Seat height** 40 cm **Feet** plastic, h. 1 cm **Available leathers** Pelle First; Pelle A *except* the colours 2530, 2531, 2532, 2533, 2536, 2537, 2538, 2539; Pelle B *only* the colours 3100, 3101, 3102, 3103, 3150, 3151, 3152 and 3153.

**Struttura** legno **Imbottitura** poliuretano indeformabile di varie densità (D35 elastico + D35 soffice + D35 super soffice nella zona seduta; D21 elastico + D23 super soffice nella parte schienale). Rivestimento in tomana 450 gr **Cerniere** disponibili nei colori: bianco (100), crema (101), senape (102), beige (103), verde (104), marrone (105), testa di moro (106), bordeaux (107), viola (108), grigio chiaro (109), grigio scuro (110), sabbia (111), grigio oliva (112), grigio ardesia (113), grigio azzurro (114) e acqua marina (115) **Altezza seduta** 40 cm **Piedi** plastica, h. 1 cm **Pelli utilizzabili** Pelle First; Pelle A ad *eccezione* dei colori 2530, 2531, 2532, 2533, 2536, 2537, 2538 e 2539; Pelle B *solo* i colori 3100, 3101, 3102, 3103, 3150, 3151, 3152 e 3153.

Armchair  
Poltrona

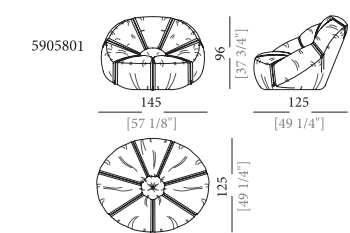

# LOVE



design  
Carlo Bimbi 2005

**Structure** varnished metal **Frame padding** cold-expanded polyurethane covered with coupled synthetic lining 6 mm **Springing** elastic belts **Seat height** 39 cm **Swivel base** base in mat stainless steel and cylinder in nickel-plated metal

**Struttura** metallo verniciato **Imbottitura fusto** poliuretano schiumato a freddo rivestito in vellutino accoppiato 6 mm **Piano di molleggio** cinghie elastiche **Altezza seduta** 39 cm **Basamento girevole** piatto in acciaio inox satinato e cilindro in metallo nichelato

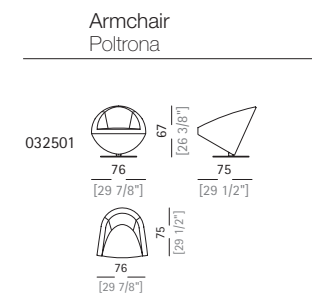

# MONTERREY



design  
Christophe Pillet 2010

**Structure** varnished metal **Arm and back upholstery** cold-expanded polyurethane foam of varied densities, with a resilient inner core D30 covered with synthetic lining 150 gr **Seat cushion upholstery** non-deformable polyurethane D35EM covered with synthetic lining 150 gr **Springing** elastic belts **Seat height** 40 cm **Arm height** 50 cm **Feet** 4 plastic feet or swivel base

**Struttura** metallo verniciato **Imbottitura bracciolo/schienale** poliuretano schiumato a freddo a densità differenziata, inserto in resina espansa D30 rivestito con tomana 150 gr **Imbottitura seduta** poliuretano indeformabile D35EM rivestito con tomana 150 gr **Piano di molleggio** cinghie elastiche **Altezza seduta** 40 cm **Altezza bracciolo** 50 cm **Piedi** 4 piedi in plastica oppure base girevole

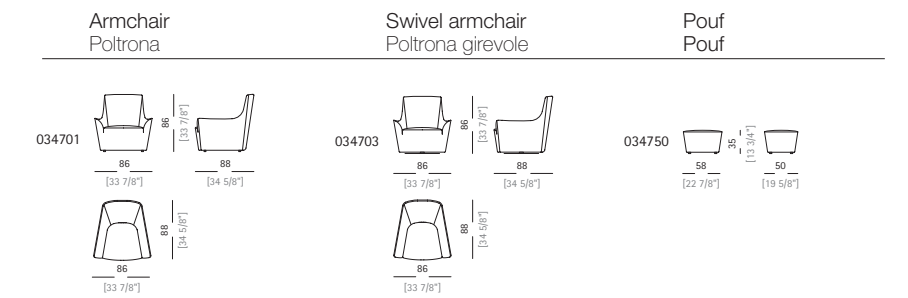

# OZIO



design  
Gordon Guillaumier 2008

**Structure** micaceous brown varnished metal, straps in anthracite grey or brown leather **Seat cushion upholstery** quilted 100% cotton cover filled with goose down and resin foam template D35 **Back cushion upholstery** quilted 100% cotton cover filled with mixed down ("rombo piuma") **Springing** elastic belts **Seat height** 44 cm

**Struttura** metallo verniciato colore marrone micaceo, strisce in cuoio colore grigio antracite o marrone **Imbottitura cuscino seduta** tessuto esterno in cotone 100% trapuntato; riempitura in piuma con dima interna in resina espansa D35 **Imbottitura cuscino schienale** tessuto esterno in cotone 100% trapuntato; riempitura rombo piuma **Piano di molleggio** cinghie elastiche **Altezza seduta** 44 cm

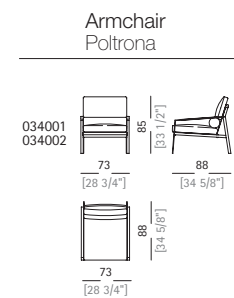

# ROXY



design  
Giuseppe Viganò 2016

**Structure** metal **Padding** non-deformable polyurethane of varied densities (T40P + HD60 + PF40P/FR) covered with coupled synthetic lining 6mm **Quilted back** available in fabrics and leathers of Arketipo collection, excluded the following ones: Decor, Vintage, Royal, Duchess, Fusion, Mousse, Moiré, Deep and leather Pelle Leonardo. It is possible to use colours or materials different from the rest of the cover, with an extra charge **Seat height** 41 cm **Swivel base** micaceous brown metal **Attention** striped and embossed fabrics are not suitable. The use of thick and patterned fabrics is not recommended because the cross seams will not show up against the cover. The whole cover is removable

**Struttura** metallo **Imbottitura** poliuretano indeformabile di varie densità (T40P + HD60 + PF40P/FR) rivestito con vellutino accoppiato 6mm **Schienale trapuntato** realizzabile in tessuto o pelle del campionario Arketipo ad esclusione delle seguenti collezioni: Decor, Vintage, Royal, Duchess, Fusion, Mousse, Moiré, Deep e della Pelle Leonardo. E' possibile usare un colore o materiale diverso dal resto del rivestimento con un supplemento **Altezza seduta** 41 cm **Base girevole** metallo marrone micaceo **Attenzione** non è possibile usare tessuti cannettati, con righe e disegni a rilievo, inoltre è sconsigliato l'uso di tessuti molto strutturati e melangiati dove l'effetto decorativo della croce scomparirebbe. Anche il rivestimento trapuntato è sfoderabile

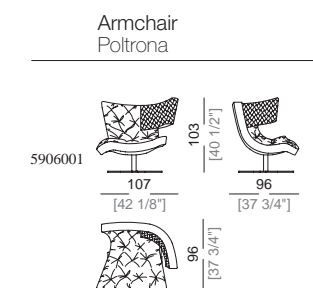

# SIN SEATY



design  
Giuseppe Viganò 2015

**Structure armchair** metal, **pouf** wood **Armchair structure padding** cold-expanded polyurethane of varied densities **Armchair seat and pouf padding** non deformable polyurethane D35 covered with synthetic lining 230gr **Quilted back** available in fabrics and leathers of Arketipo collection, excluded the following collections: Decor, Vintage, Royal, Duchess, Fusion, Mousse, Moiré and leather Pelle Leonardo. It is possible to use colours or materials different from the rest of the cover, with an extra charge **Seat height** 42 cm **Arm height** 55 cm **Feet and swivel base** metal, finishes micaceous brown or titanium **Attention** the pouf for the swivel armchair is fixed

**Struttura poltrona** in metallo, **pouf** in legno **Imbottitura struttura poltrona** poliuretano schiumato a freddo a densità differenziate **Imbottitura seduta poltrona e pouf** poliuretano indeformabile D35 rivestito con tomana da 230gr **Schienale trapuntato** è realizzabile in tessuto o pelle del campionario Arketipo ad esclusione delle seguenti collezioni: Decor, Vintage, Royal, Duchess, Fusion, Mousse, Moiré e della Pelle Leonardo. E' possibile usare un colore o materiale diverso dal resto del rivestimento con un supplemento **Altezza seduta** 42 cm **Altezza bracciolo** 55 cm **Piedi e base girevole** metallo, finiture marrone micaceo o titanio **Attenzione** Il pouf per poltrona girevole non ha la base girevole

# TWIGGY



design  
Giuseppe Viganò 2015

**Structure** metal, back in wood **Seat and arm upholstery** non-deformable polyurethane of varied densities (D35 elastic + D40) covered with polyester fibre coupled with cotton **Back upholstery** non-deformable polyurethane of varied densities (D35 super soft + D60 rigid) covered with polyester fibre coupled with cotton **Seat height** 45 cm **Arm height** 60 cm **Metal parts** finishes: micaceous brown or titanium **Piping** available in the same leather as the back **Attention** the quilted back is available only in Arketipo leathers and the cover is not removable

**Struttura** metallo, schienale in legno **Imbottitura seduta e braccioli** poliuretano indeformabile di varie densità (D35 elastico + D40 portante) rivestito con fibra di poliestere accoppiata a cotone **Imbottitura schienale** poliuretano indeformabile di varie densità (D35 super soffice + D60 rigido) rivestito con fibra di poliestere accoppiata a cotone **Altezza seduta** 45 cm **Altezza bracciolo** 60 cm **Parti metalliche** finiture: marrone micaceo o titanio **Bordino** realizzato con la stessa pelle dello schienale **Attenzione** lo schienale trapuntato è realizzato nelle pelli del campionario Arketipo e non è sfoderabile

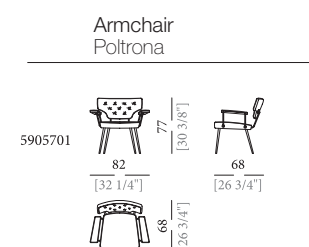
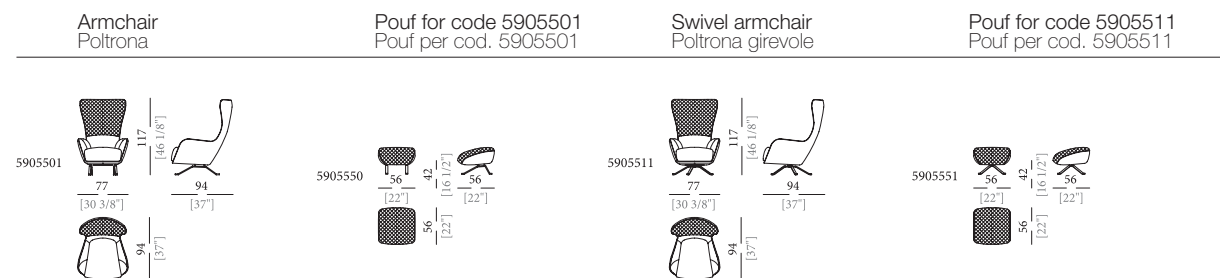

# AUTO-REVERSE DREAM

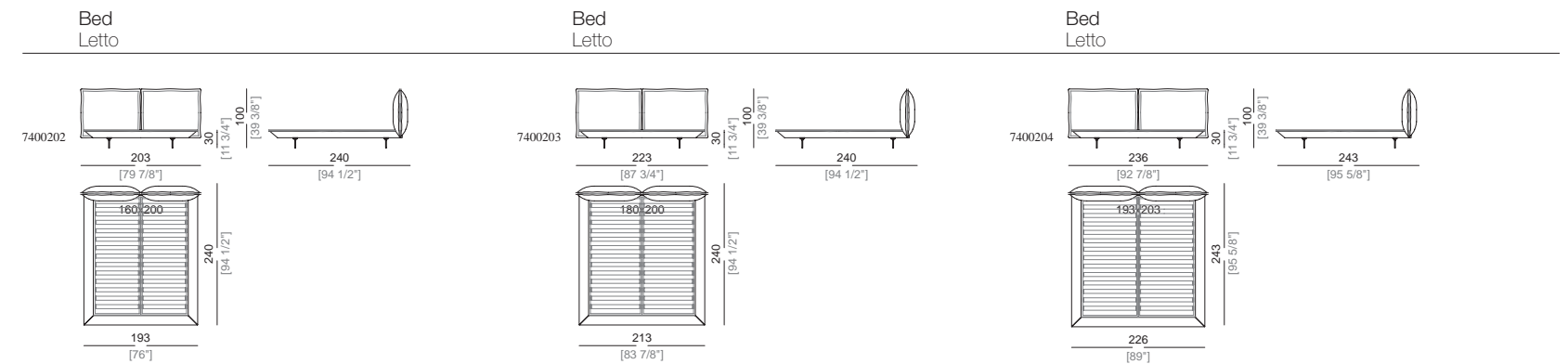

design  
Giuseppe Viganò 2013

**Structure** metal; slatted base **Frame padding** non deformable polyurethane (SR75 + D40 + D18) covered with synthetic lining 150 gr and coupled lining 6 mm **Headboard cushions padding** outer side in 100% white Gabardine 30/20 cotton cover. Filling in 65% goose down and 35% duck down **Slats height** 20 cm **Feet** metal, finishes: micaceous brown, brass or titanium, h. 19 cm **Zips** available in the following colours: white (100), cream white (101), mustard (102), beige (103), green (104), brown (105), dark brown (106), burgundy (107), purple (108), light grey (109), dark grey (110), sand beige (111), olive grey (112), slate grey (113), light blue grey (114) and aquamarine blue (115). The headboard cushions are reversible and they can be covered with different fabrics and/or leathers. The cover of the structure is always in the same fabric or leather of one side of the cushions.

**Struttura** metallo; rete con doghe in legno **Imbottitura fusto** poliuretano indeformabile (SR75 + D40 + D18) rivestito con Tomana 150 gr e fodera di vellutino accoppiato 6 mm **Imbottitura cuscini testiera** tessuto esterno in Gabardina 30/20 bianco (100% cotone). Imbottitura miscela con 65% di piuma d'oca e 35% piuma d'anatra **Altezza piano rete** 20 cm **Piedi** metallo, finiture: marrone micaceo, titanio o ottone, h. 19 cm **Cerniere** disponibili nei colori: bianco (100), crema (101), senape (102), beige (103), verde (104), marrone (105), testa di moro (106), bordeaux (107), viola (108), grigio chiaro (109), grigio scuro (110), sabbia (111), grigio oliva (112), grigio ardesia (113), grigio azzurro (114) e acqua marina (115). I cuscini della testiera sono double-face e possono essere realizzati con tessuti e pelli differenti. Il rivestimento della struttura è sempre uguale ad un lato delle cuscinate.

# CRAZY DREAM



design  
Giuseppe Viganò 2016

**Structure** wood **Frame upholstery** expanded polyurethane D40 covered with synthetic lining 230gr **Headboard upholstery** expanded polyurethane D28; outer cover in 100% down proof white cotton filled with 100% natural goose down and quilted synthetic lining 230gr **Slats height** 20 cm **Feet** metal, finishes: micaceous brown or titanium

**Struttura** legno **Imbottitura fusto** poliuretano espanso D40, rivestito con Tomana 230gr **Imbottitura fusto testiera** poliuretano espanso D28, rivestito con cotone 100% antipiuma bianco riempito in piuma naturale 100% e con Tomana trapuntata 230gr **Altezza piano rete** 20 cm **Piedi** metallo, finiture: marrone micaceo o titanio

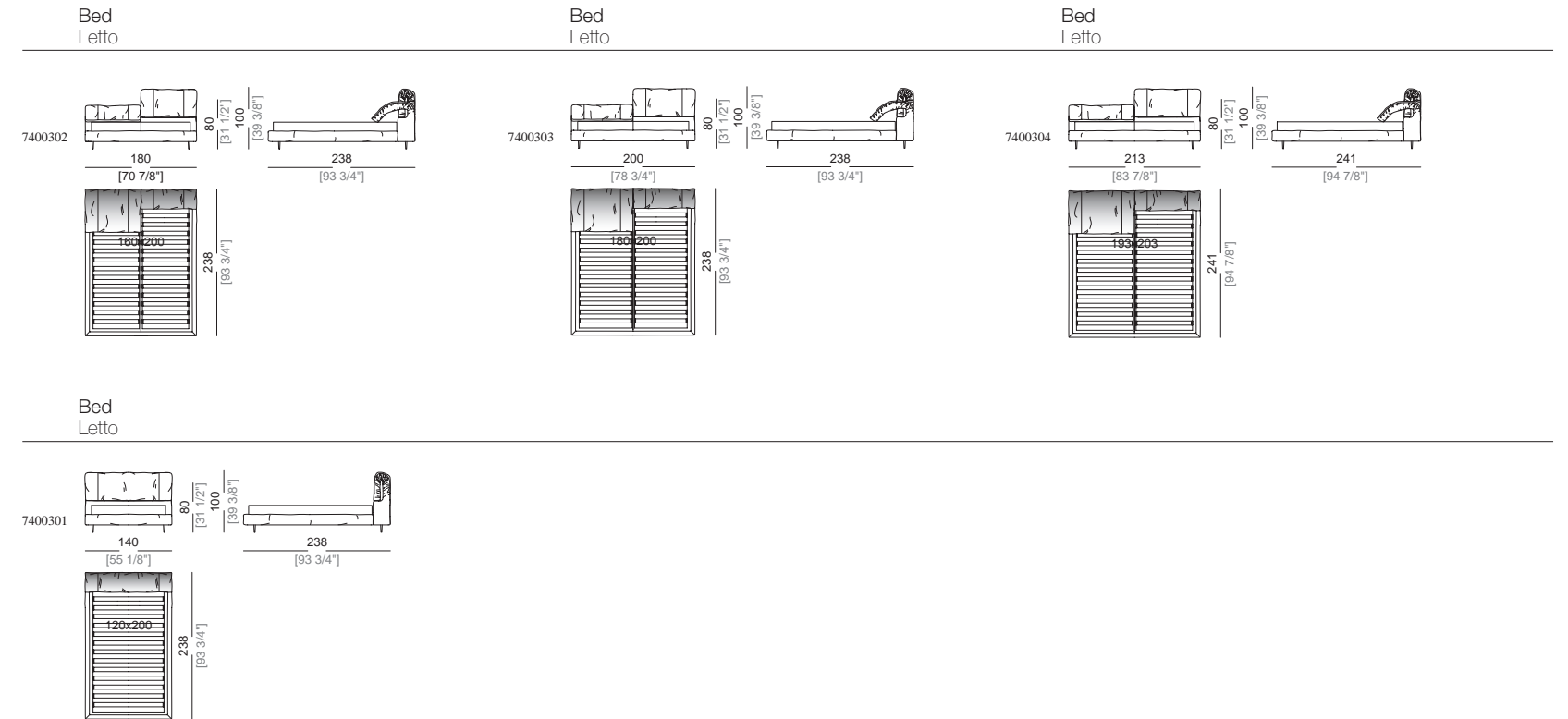



# WINDSOR DREAM



design  
Manzoni & Tapinassi 2013

**Structure** wood; slatted base **Frame padding** non deformable polyurethane (D30 + D35) covered with Dacron 400 gr **Slats height** 21 cm **Feet** metal with insert in beech wood, covered with leather or velvet h. 14 cm. Underfoot in steel. The cover is not removable. It is available in velvet (our collection "Vellù" or velvet supplied by the client) or in the following leathers: "First", "A", "B", "Leonardo", C.O.L. max thickness 1,3 mm.

**Struttura** legno; rete con doghe in legno **Imbottitura fusto** poliuretano indeformabile (D30 + D35) rivestito con Dacron 400 g **Altezza piano rete** 21 cm **Piedi** metallo con inserto in legno di faggio, rivestiti in pelle o velluto, h. 14 cm; sottopiede in acciaio. Il letto non è sfoderabile. Può essere realizzato in velluto (collezione "Vellù" o velluto fornito dal cliente) o nelle seguenti pelli: "First", "A", "B", "Leonardo", pelle cliente massimo spessore 1,3 mm.

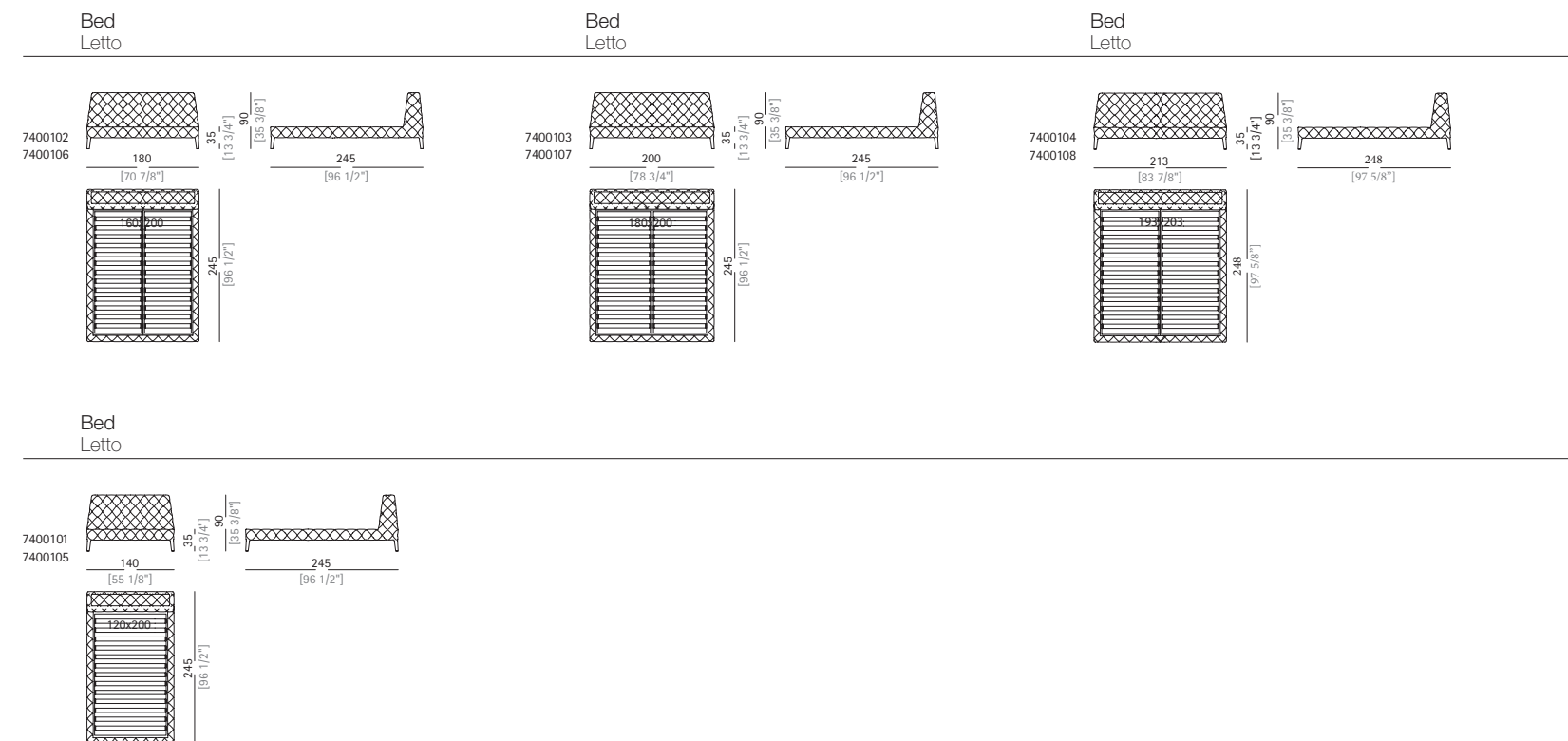

# AKA



design  
Mauro Lipparini 2016

**Structure** metal, finishes: micaceous brown, oxy grey or black nickel **Top** wood veneered in moka oak, sucupira or glossy ebony

**Struttura** metallo, finiture: marrone micaceo, oxy grey o black nickel **Piano** legno impiallacciato rovere moka, sucupira o ebano lucido

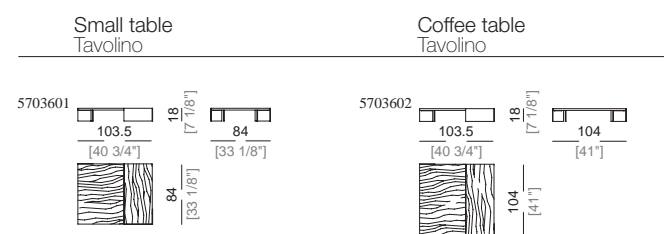

# ARMONIA



design  
Gordon Guillaumier 2008

**Base** micaceous brown varnished metal **Top** MDF veneered in moka oak, Canaletto walnut or sucupira wood

**Base** metallo verniciato colore marrone micaceo **Piano** MDF impiallacciato rovere moka, noce Canaletto o sucupira

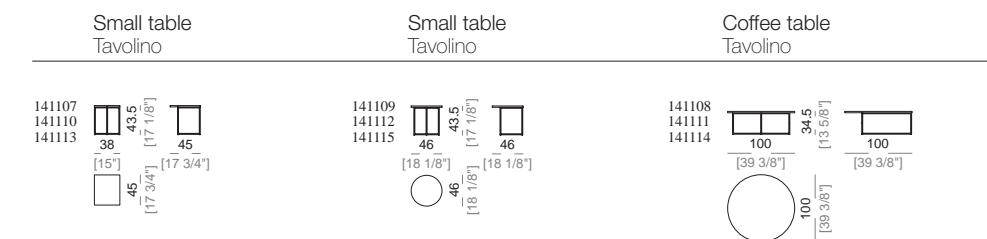

# DOWNTOWN



design  
Manzoni & Tapinassi 2015

**Structure** metal, finishes micaceous brown or titanium **Table and console tops** MDF veneered: lower top in moka oak and upper top in moka oak, glossy polyester laquered or MDF veneered in sucupira for both tops **Side table top** MDF veneered in moka oak or MDF veneered in moka oak, glossy polyester laquered or MDF veneered in sucupira.

**Struttura** metallo, finiture marrone micaceo o titanio **Piani del tavolino e della consolle** MDF impiallacciato: piano inferiore in rovere moka e superiore in rovere moka laccato poliestere lucido oppure MDF impiallacciato sucupira per entrambi i piani **Piano tavolino fianco divano** MDF impiallacciato rovere moka oppure MDF impiallacciato rovere moka laccato poliestere lucido oppure MDF impiallacciato sucupira.

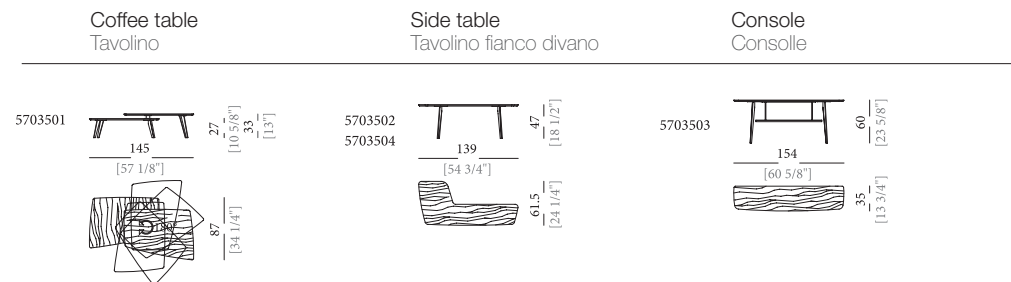

# ELAS



design  
Mauro Lipparini 2016

**Structure** metal, finishes: micaceous brown, oxy grey or black nickel. **Upper top** wood veneered in moka oak, sucupira or glossy ebony **Lower top and sides** wood veneered in moka oak, sucupira or ebony.

**Struttura** metallo, finiture: marrone micaceo, oxy grey o black nickel **Piano superiore** legno impiallacciato rovere moka, sucupira o ebano lucido **Piano inferiore e fianchi** legno impiallacciato rovere moka, sucupira o ebano.

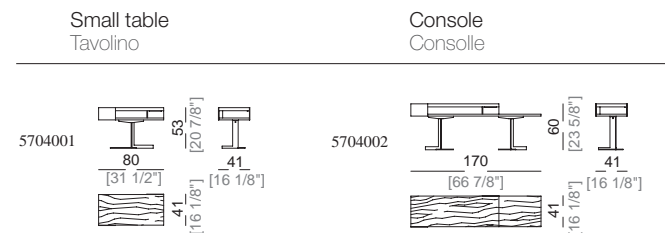

# ISOLA



design  
Gordon Guillaumier 2008

**Base** micaceous brown varnished metal **Glass finish: Tops** laminated tempered glass. Top surface in smoked glass, underside varnished in grey **Console shelf** sheet-metal, micaceous brown stained **Other finishes for small tables (sandstone or mdf cement brushed or wood): Top** mdf cement brushed or mdf veneered in moka oak, Canaletto walnut, sucupira wood or sandstone "coffee-cream" colour, water and oil repellent. Not acid-resistant **Lower shelf** sheet-metal, micaceous brown stained  
The cement finish is not uniform as the brushing of the material is hand-made

**Base** metallo verniciato colore marrone micaceo **Versione in vetro: Piani** vetro temperato stratificato colore fumè, retro verniciato grigio **Ripiano console** lamiera verniciata colore marrone micaceo **Altre finiture per tavolini (pietra arenaria o mdf spatolato cemento o legno): Piano superiore** mdf spatolato cemento o mdf impiallacciato noce Canaletto, sucupira, rovere moka o pietra Arenaria color "moka-cream", trattata per renderla repellente ad olio e acqua. Non resiste a sostanze acide **Piano inferiore** lamiera verniciata colore marrone micaceo  
La finitura cemento risulta di aspetto irregolare poiché la spatolatura del materiale sul supporto viene realizzata manualmente

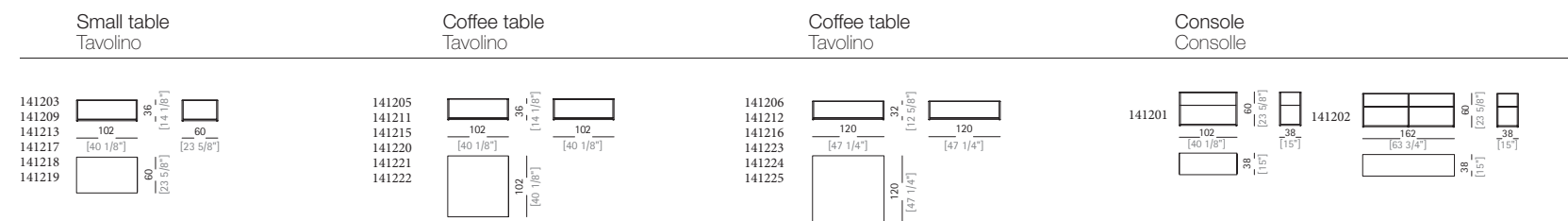

# LITH



design  
Mauro Lipparini 2016

**Base** metal, finishes: micaceous brown, oxy grey or black nickel **Top** matt Emperador marble, sandstone or tempered smoked glass

**Base** metallo, finiture: marrone micaceo, oxy grey o black nickel **Piano** marmo Emperador opaco o pietra arenaria o vetro temperato colore fumè

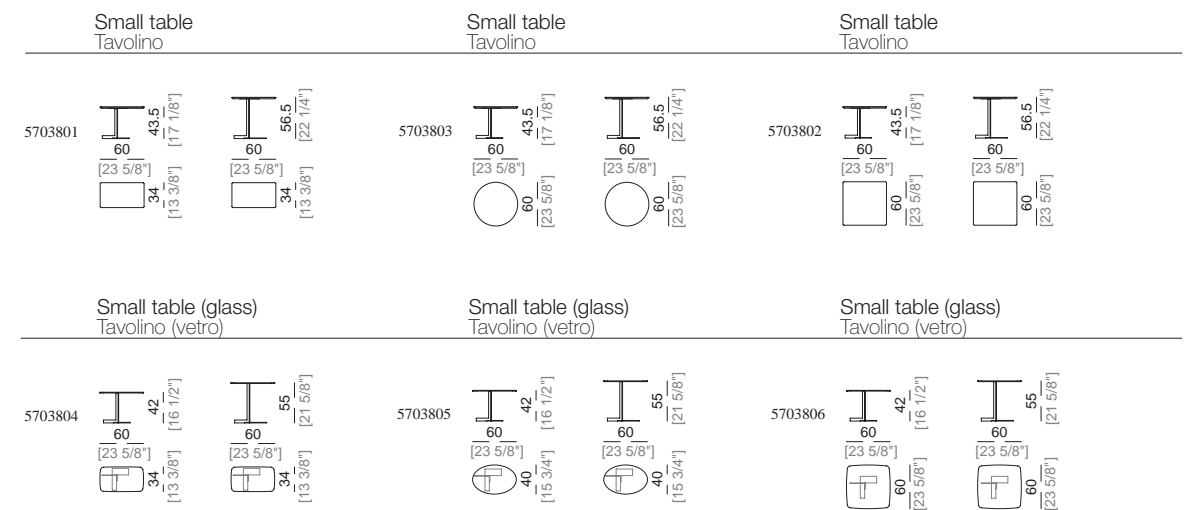

# LOFT



design  
Massimo Lorusso 2006

**Structure** inox steel **Top** polished inox steel  
**Struttura** acciaio inox **Piano** acciaio inox lucido

Occasional table  
Tavolino

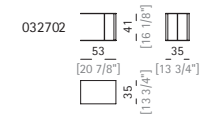

Occasional table  
Tavolino

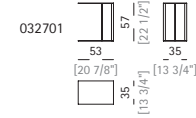

# NELSON



design  
Manzoni & Tapinassi 2015

**Structure** metal, micaceous brown finish **Tops** MDF veneered in composite ebony with glossy transparent polyester finish, sucupira or moka oak. In the versions 149x62,5 cm and 100x100 cm one top is covered with leather Pelle Leonardo.

**Struttura** metallo, finitura marrone micaceo **Piani** MDF impiallacciato ebano precomposto verniciato trasparente lucido poliesteri, sucupira o rovere moka. Nelle versioni 149x62,5 cm e 100x100 cm un piano è rivestito in Pelle Leonardo.

Occasional table  
Tavolino

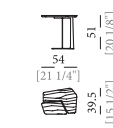

Coffee table  
Tavolino

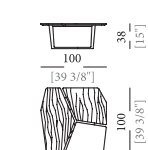

Coffee table  
Tavolino

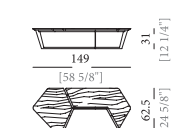

# NOTH



design  
Mauro Lipparini 2016

**Structure** metal, finishes: micaceous brown, oxy grey or black nickel **Upper top** wood veneered in moka oak, sucupira or glossy ebony **Lower top and sides** wood veneered in moka oak, sucupira or ebony.

**Struttura** metallo, finiture: marrone micaceo, oxy grey o black nickel **Piano superiore** legno impiallacciato rovere moka, sucupira o ebano lucido **Piano inferiore e fianchi** legno impiallacciato rovere moka, sucupira o ebano

# PETRA



design  
Bartoli Design 2013

**Base** metal, finishes: micaceous brown, titanium or brass **Top** mat Emperador marble or sandstone

**Base** metallo, finiture: marrone micaceo, titanio o ottone **Piano** marmo Emperador opaco o pietra arenaria

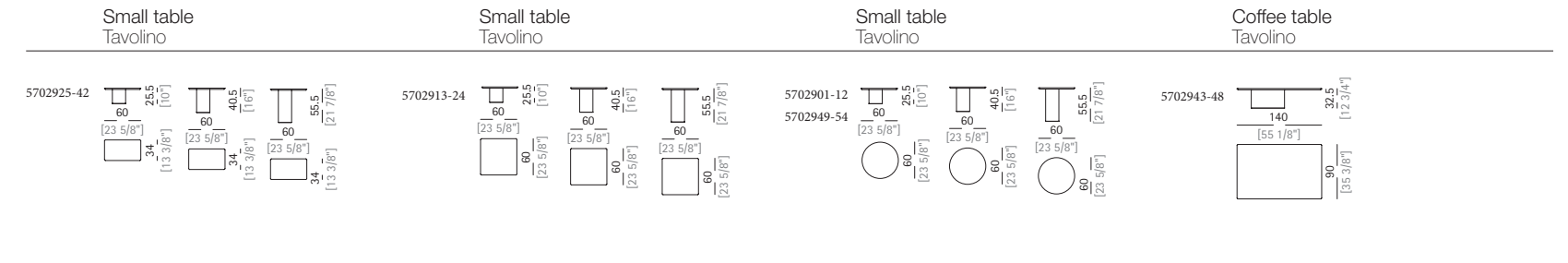
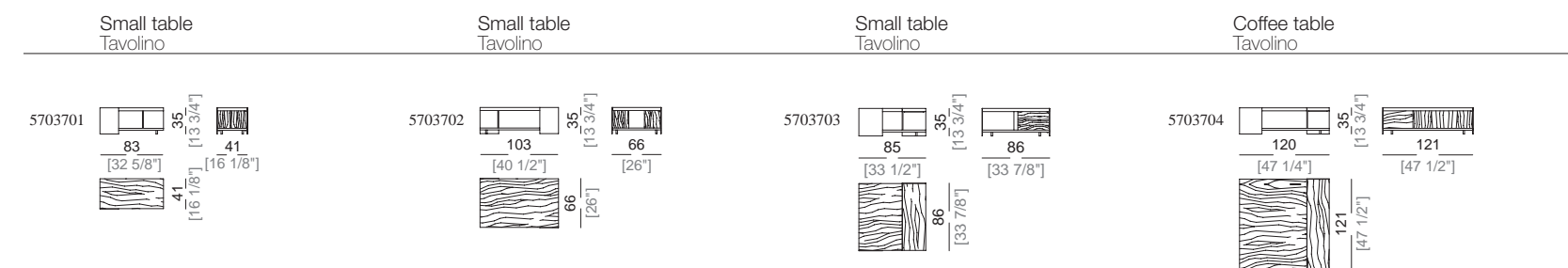

# PLANET



design  
Carlo Bimbi 2007

**Structure** chromed metal **Top** polished stainless steel  
**Struttura** metallo cromato **Piano** acciaio inox lucido

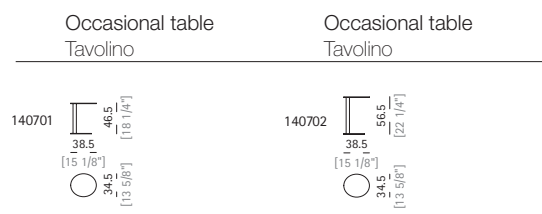

# REBUS

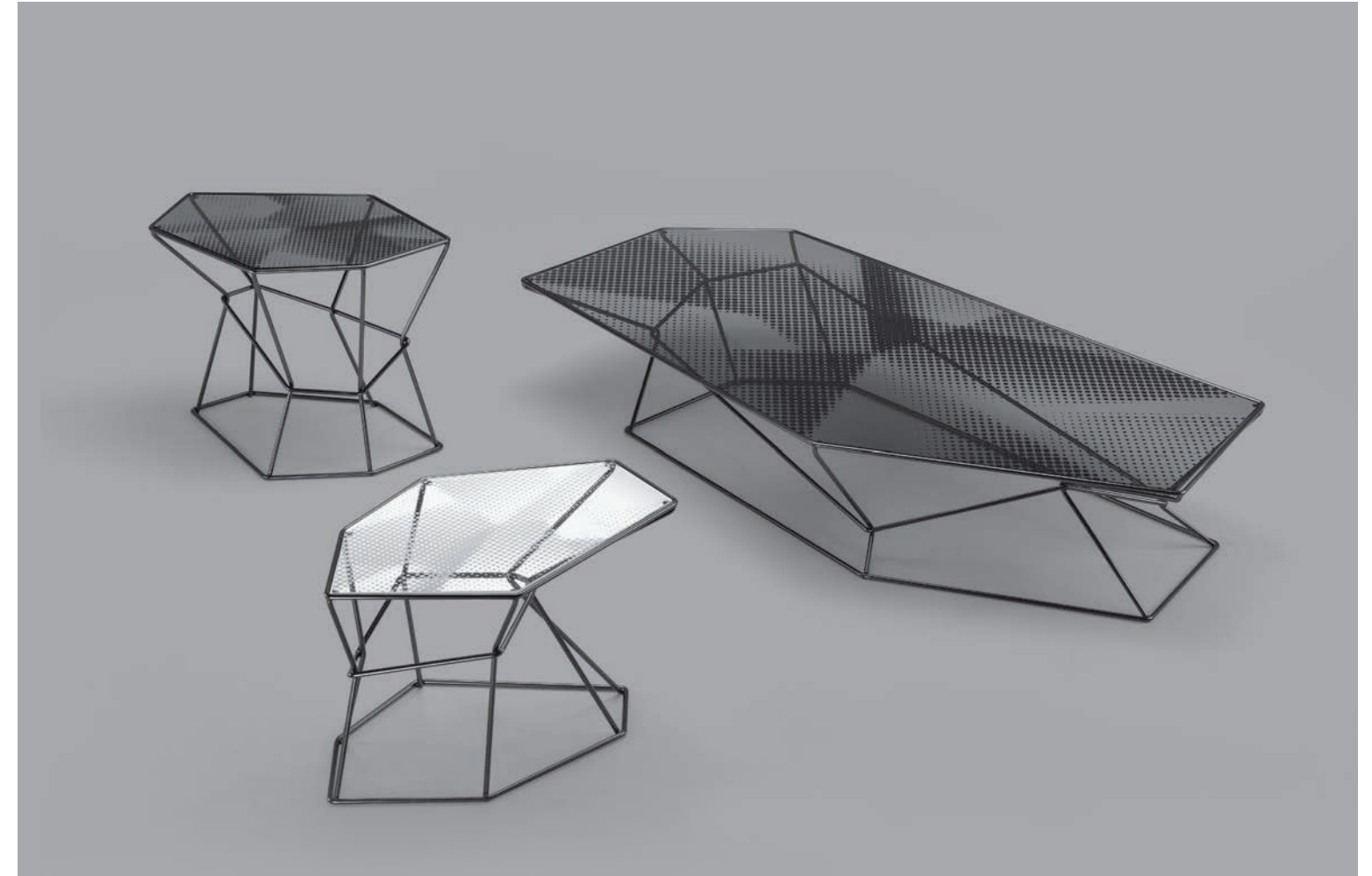

design  
Mauro Lipparini 2014

**Structure** metal, micaceous brown or titanium **Top** transparent or smoked silk-screened glass, thickness 8 mm  
**Struttura** metallo verniciato colori marrone micaceo o titanio **Piano** vetro serigrafato trasparente o fumé, spessore 8 mm

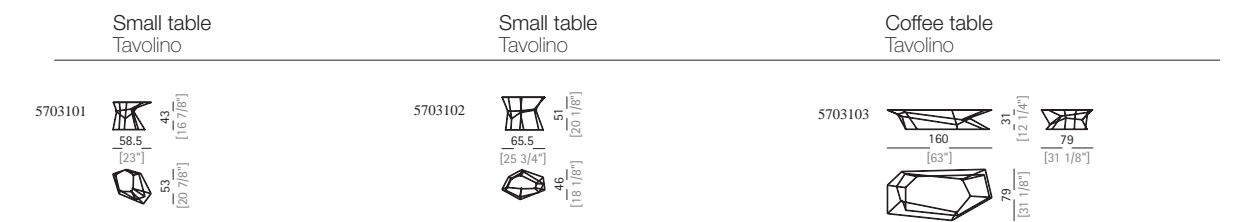

# SPACE INVADERS



design  
Gino Carollo 2014

**Base** metal, micaceous brown, titanium or brass **Top** melamine faced chipboard covered with leather Pelle Leonardo: small table 48x32 h. 50 cm - leather Pelle Leonardo 1001-1002; small table 90x90 h. 39 cm - leather Pelle Leonardo 1007-1003-1008; small table 130x70 h. 30 cm - leather Pelle Leonardo 1001-1010-1011 **Two edges** wood veneered in sucupira or solid wood, Canaletto walnut or moka oak stained **Feet and other edges** metal: micaceous brown, titanium or brass

**Base** metallo: marrone micaceo, titanio o ottone **Piano** truciolato melamminico rivestito in Pelle Leonardo, così composto: tavolino 48x32 h. 50 cm Pelle Leonardo 1001-1002; tavolino 90x90 h. 39 cm. Pelle Leonardo 1007-1003-1008; tavolino 130x70 h. 30 cm. Pelle Leonardo 1001-1010-1011 **Bordi** in legno impiallacciato sucupira o in massello di legno tinto noce Canaletto o rovere moka **Piedi e profili** metallo: marrone micaceo, titanio o ottone

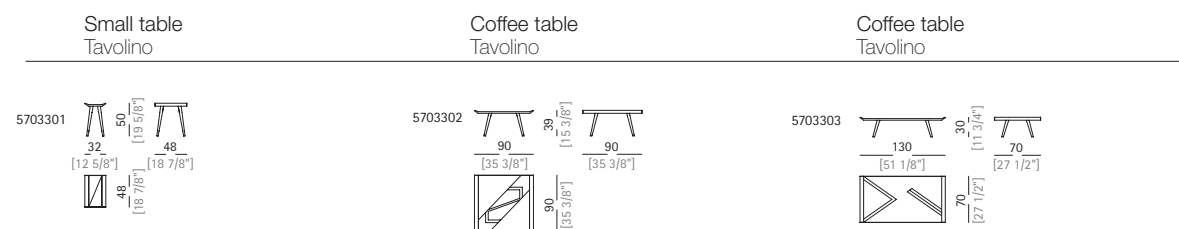

# STIJL



design  
Giuseppe Viganò 2013

**Structure** metal, finishes: micaceous brown, brass or titanium **Top** MDF veneered in the following finishes: **A1** - Canaletto walnut, one acid etched glass with underside varnished in grey-brown and two mdf cement brushed tops. **A2** - oak moka wood, one acid etched glass with underside varnished in grey-brown and two mdf cement brushed tops. **A3** - sucupira wood, one acid etched glass with underside varnished in grey-brown and two mdf cement brushed tops  
The cement finish is not uniform as the brushing of the material is hand-made

**Struttura** metallo, finiture: marrone micaceo, ottone o titanio **Piano** MDF impiallacciato nelle versioni: **A1** - legno noce Canaletto, cristallo acidato retro verniciato marrone-grigio e mdf spatolato cemento. **A2** - legno rovere moka, cristallo acidato retro verniciato marrone-grigio e mdf spatolato cemento. **A3** - legno sucupira, cristallo acidato retro verniciato marrone-grigio e mdf spatolato cemento  
La finitura cemento risulta di aspetto irregolare poiché la spatolatura del materiale sul supporto viene realizzata manualmente

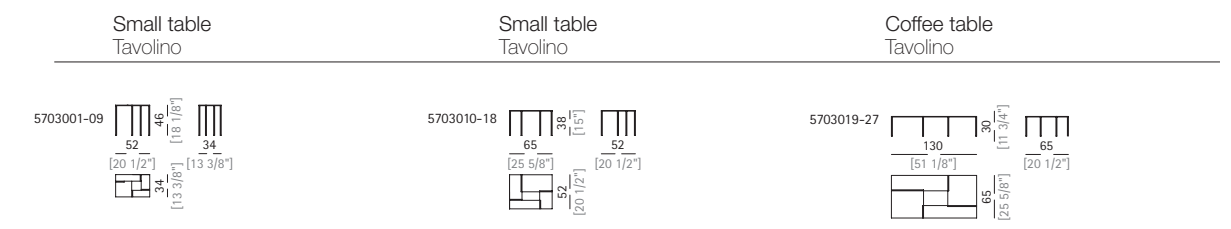



# ULA



design  
Giannella Ventura 2005

**Structure** polished steel or metal, brass finish **Top** grey "Europa" tempered glass  
**Struttura** acciaio lucido o metallo finitura ottone **Piano** cristallo grigio "Europa" temperato

Small table  
Tavolino

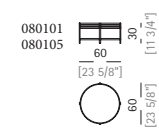

Small table  
Tavolino

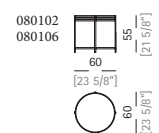

Coffee table  
Tavolino

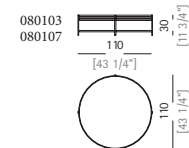

# EPSILON



design  
Manzoni & Tapinassi 2016

**Base** moka oak or sucupira wood with metal profile, finishes: micaceous brown, oxy grey, titanium or brass **Top** moka oak or sucupira wood with metal insert, finishes: micaceous brown, oxy grey, titanium or brass.

**Base** legno rovere moka o sucupira con profilo in metallo, finiture: marrone micaceo, oxy grey, titanio o ottone **Piano** legno rovere moka o sucupira con inserto in metallo, finiture: marrone micaceo, oxy grey, titanio o ottone.

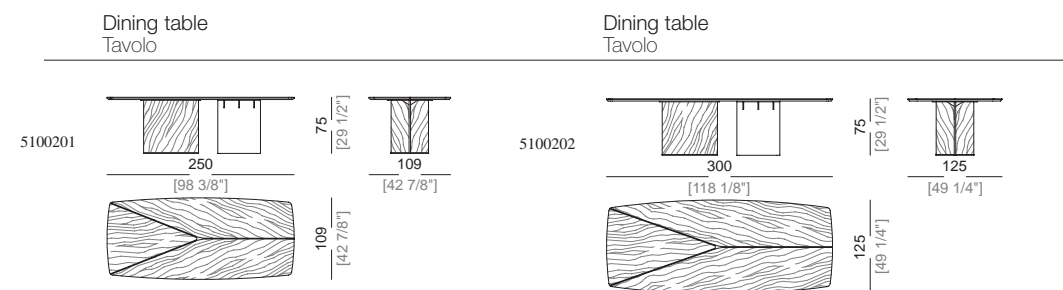

# GLORIOUS



design  
Manzoni & Tapinassi 2014

**Base** legs in solid walnut, stained moka, Canaletto walnut or sucupira. Metal bar under the top micaceous brown. **Metal struts and plates**, micaceous brown, titanium or brass **Top** MDF veneered in Canaletto walnut, moka oak or sucupira. Edges in solid walnut, stained in the same colour of the top **Drawer** covered in leather Pelle Leonardo

**Base** gambe in massello di noce tinto moka, noce Canaletto o sucupira. Trave inferiore in metallo marrone micaceo. **Tiranti e piastre** in metallo: marrone micaceo, titanio o ottone **Piano** MDF impiallacciato noce Canaletto, rovere moka o sucupira. Bordi in massello di noce tinti nello stesso colore del piano **Cassetto** rivestito in Pelle Leonardo

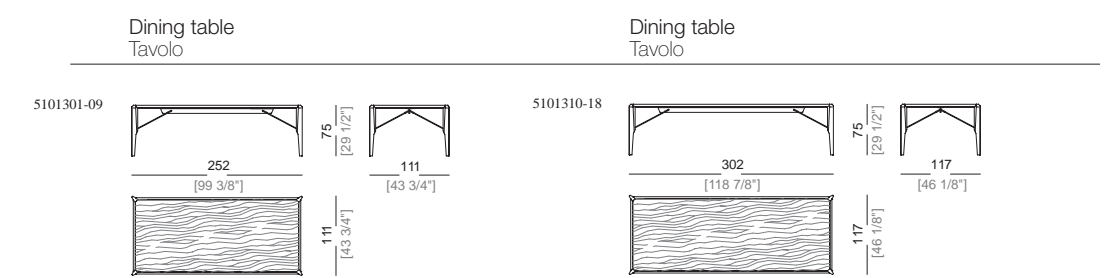

# GREENWICH



design  
Manzoni & Tapinassi 2013

**Base** Ash wood, Canaletto walnut or oak moka or sucupira. Ring in metal, finishes: micaceous brown or titanium or brass  
**Top** MDF veneered in Canaletto walnut, moka oak or sucupira wood

**Base** frassino tinto noce Canaletto, rovere moka o sucupira. Anello in metallo, finitura: marrone micaceo, titanio o ottone  
**Piano** MDF impiallacciato noce Canaletto, rovere moka o sucupira

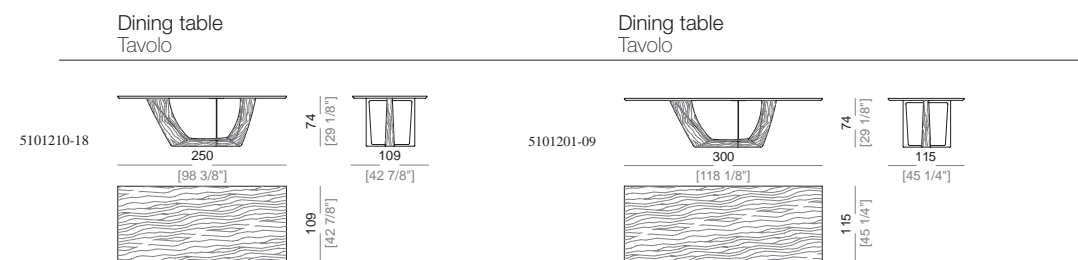

# JIG XXL



design  
Bartoli Design 2013

**Structure and top** MDF veneered in Canaletto walnut or oak moka or sucupira wood

**Struttura e piano** MDF impiallacciato legno noce Canaletto o rovere moka o sucupira

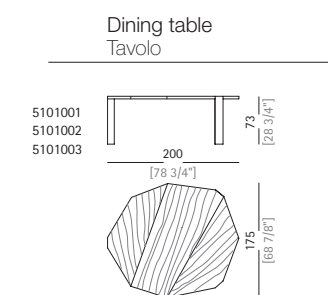

# ORACLE



design  
Gino Carollo 2016

**Base** metal, finishes: micaceous brown, oxy grey, titanium or brass **Top** MDF veneered in moka oak or sucupira or Emperador marble

**Base** metallo, finiture: marrone micaceo, oxy grey, titanio o ottone **Piano** MDF impiallacciato rovere moka o sucupira o marmo Emperador

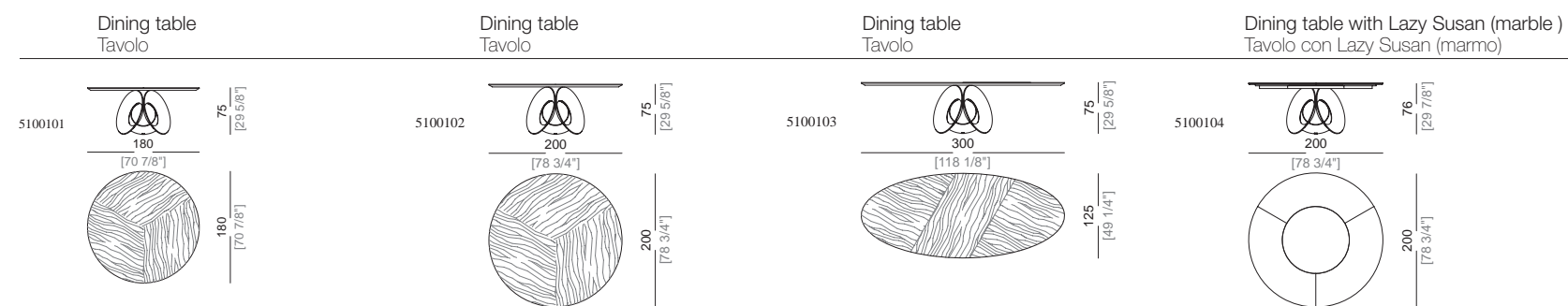

# ATHENA



design  
Mauro Lipparini 2013

**Structure** wood **Padding** non-deformable polyurethane of varied densities (HD60 and VH3545) covered with coupled synthetic lining 3 mm **Seat height** 49 cm **Feet** metal, finishes: micaceous brown, titanium or brass. The following fabrics are not recommended: Camisia, Patsy, C.O.L. max thickness 1,3 mm.

**Struttura** legno **Imbottitura** poliuretano indeformabile di varie densità (HD60 e VH3545) rivestito con vellutino accoppiato 3 mm **Altezza seduta** 49 cm **Piedi** metallo, finitura: marrone micaceo, titanio o ottone. I seguenti tessuti sono sconsigliati: Camisia e Patsy. Pelle cliente massimo spessore 1,3 mm.

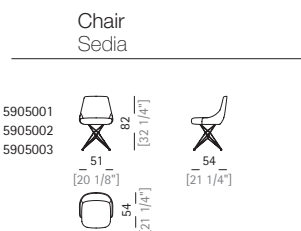

# CALMA



design  
Gordon Guillaumier 2008

**Structure** metal, finishes: polished chrome-plated, micaceous brown or oxy grey **Seat/back** leatherette: white, dark brown, liquorice and black. Leather: Dirt, Tribe and leather Pelle Leonardo **Seat height** 45 cm **Arm height** 62 cm

**Struttura** metallo, finiture: cromo lucido, marrone micaceo o oxy grey **Sedile/schienale** cuoietto: bianco, testa di moro, liquirizia e nero. Cuoio: Dirt, Tribe e Pelle Leonardo **Altezza seduta** 45 cm **Altezza bracciolo** 62 cm

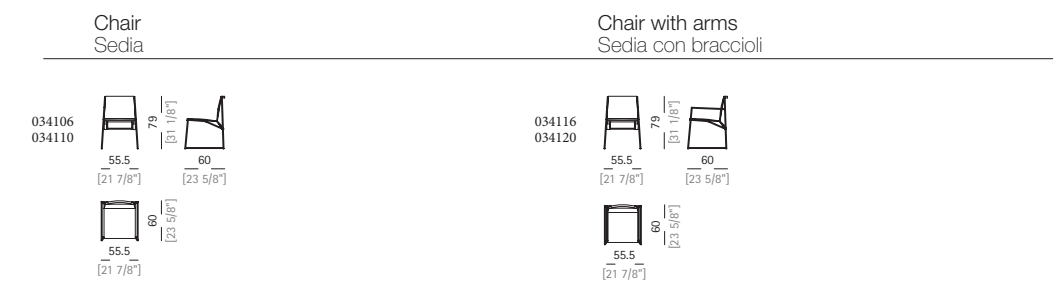

# EMILY



design  
Manzoni & Tapinassi 2014

**Structure** metal; seat in birch plywood **Padding** non deformable polyurethane 40Pk **Cover** Leatherette: white, dark brown, liquorice and black. Leather: Dirt and Tribe **Seat height** 47,5 cm

**Struttura** metallo; piano seduta in legno multistrato di betulla **Imbottitura** poliuretano indeformabile 40Pk **Rivestimento** cuoietto: bianco, testa di moro, liquirizia e nero. Cuoio: Dirt e Tribe **Altezza seduta** 47,5 cm

Chair  
Sedia

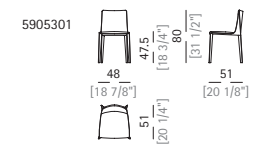

# GOLDIE



design  
Manzoni & Tapinassi 2015

**Structure** wood and metal **Padding** non-deformable polyurethane (density T40) covered with coupled synthetic lining 5mm **Seat height** 46 cm

**Attention** the cover is not removable. The seat cover of the chair code 5905902 is removable only when it is in fabric

**Struttura** legno e metallo **Imbottitura** poliuretano indeformabile (densità T40) rivestito con vellutino accoppiato 5 mm **Altezza seduta** 46 cm

**Attenzione** la sedia non è sfoderabile. La seduta della sedia cod. 5905902 è sfoderabile solo quando è in tessuto

DUO Chair completely upholstered in two leathers  
DUO Sedia completamente rivestita con due pelli

MATCH Chair with structure in leather and seat cushion in leather or fabric  
MATCH Sedia con struttura in pelle e seduta in pelle o tessuto

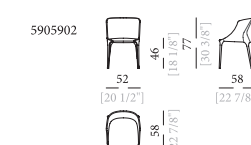
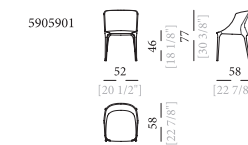

# MISS MALICE



design  
Studio Arketipo 2014

**Structure** metal frame; seat in beech wood **Padding** non deformable polyurethane density T40PCM covered with coupled synthetic lining mm.6 and synthetic lining 180 gr **Seat height** 48 cm **Feet** metal: micaceous brown, titanium or brass

**Struttura** base e schienale in metallo; piano seduta in legno di faggio **Imbottitura** poliuretano indeformabile densità T40PCM rivestito con vellutino accoppiato mm.6 e con tomata 180 gr **Altezza seduta** 48 cm **Piedi** metallo: marrone micaceo, titanio o ottone

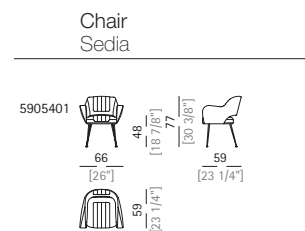

# VENUS



design  
Mauro Lipparini 2013

**Structure** wood **Padding** non-deformable polyurethane (density T50/D) covered with coupled synthetic lining 6 mm **Seat height** 48 cm **Feet** metal, finishes: micaceous brown, titanium or brass **Attention** the following fabrics are not recommended: Camisia, Patsy, Royal and Decor. C.O.L. max thickness 1,3mm

**Struttura** legno **Imbottitura** poliuretano indeformabile (densità T50/D) rivestito con vellutino accoppiato 6 mm **Altezza seduta** 48 cm **Piedi** metallo, finiture: marrone micaceo, titanio o ottone **Attenzione** i seguenti tessuti sono sconsigliati: Camisia, Patsy, Royal e Decor. Pelle cliente massimo spessore 1,3 mm

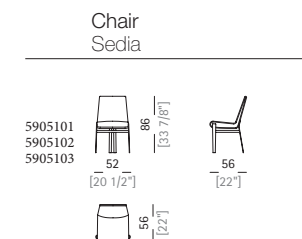

# AURA



design  
Giuseppe Viganò 2016

**Structure** wood veneered in moka oak or sucupira **Metal parts** metal, finishes: micaceous brown, oxy grey, titanium or brass **Top** Emperador marble or acid etched glass, underside varnished in grey-brown

**Struttura** legno impiallacciato rovere moka o sucupira **Parti metalliche** metallo, finiture: marrone micaceo, oxy grey, titanio o ottone **Piano** marmo Emperador o cristallo acidato retro verniciato marrone-grigio

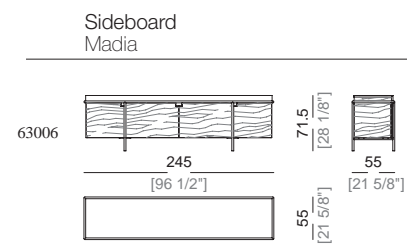

# LONGPLAY



design  
Manzoni & Tapinassi 2013

**Structure** MDF veneered in Canaletto walnut, moka oak or sucupira wood. Vertical panels stained beige Pantone 7529C. Drawn metal, finishes: micaceous brown, titanium or brass **Top** acid etched glass, underside varnished in grey-brown or mat Emperador marble **Feet** ash wood, Canaletto walnut, moka oak or sucupira stained

**Struttura** MDF impiallacciato noce Canaletto, rovere moka o sucupira. Divisori verticali verniciati colore beige (Pantone 7529C). Trafilato in metallo, finiture: marrone micaceo o titanio o ottone **Piano** Cristallo acidato retro verniciato marrone-grigio o marmo Emperador opaco **Piedi** Frassino tinto noce Canaletto, rovere moka o sucupira

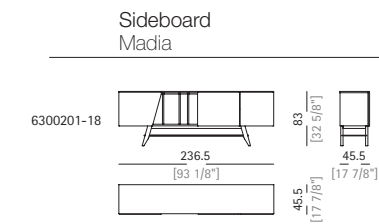



# ENDOR & ENDOR SHELF



design  
Mauro Lipparini 2016

**Top and structure** wood veneered in moka oak, sucupira or glossy/matt ebony **Metal parts** metal, finishes: micaceous brown, oxy grey or black nickel **Doors** wood covered with leather Pelle Leonardo

**Piano e struttura** legno impiallacciato rovere moka, sucupira o ebano lucido/opaco **Parti metalliche** metallo, finiture: marrone micaceo, oxy grey o black nickel **Ante** legno rivestito in Pelle Leonardo

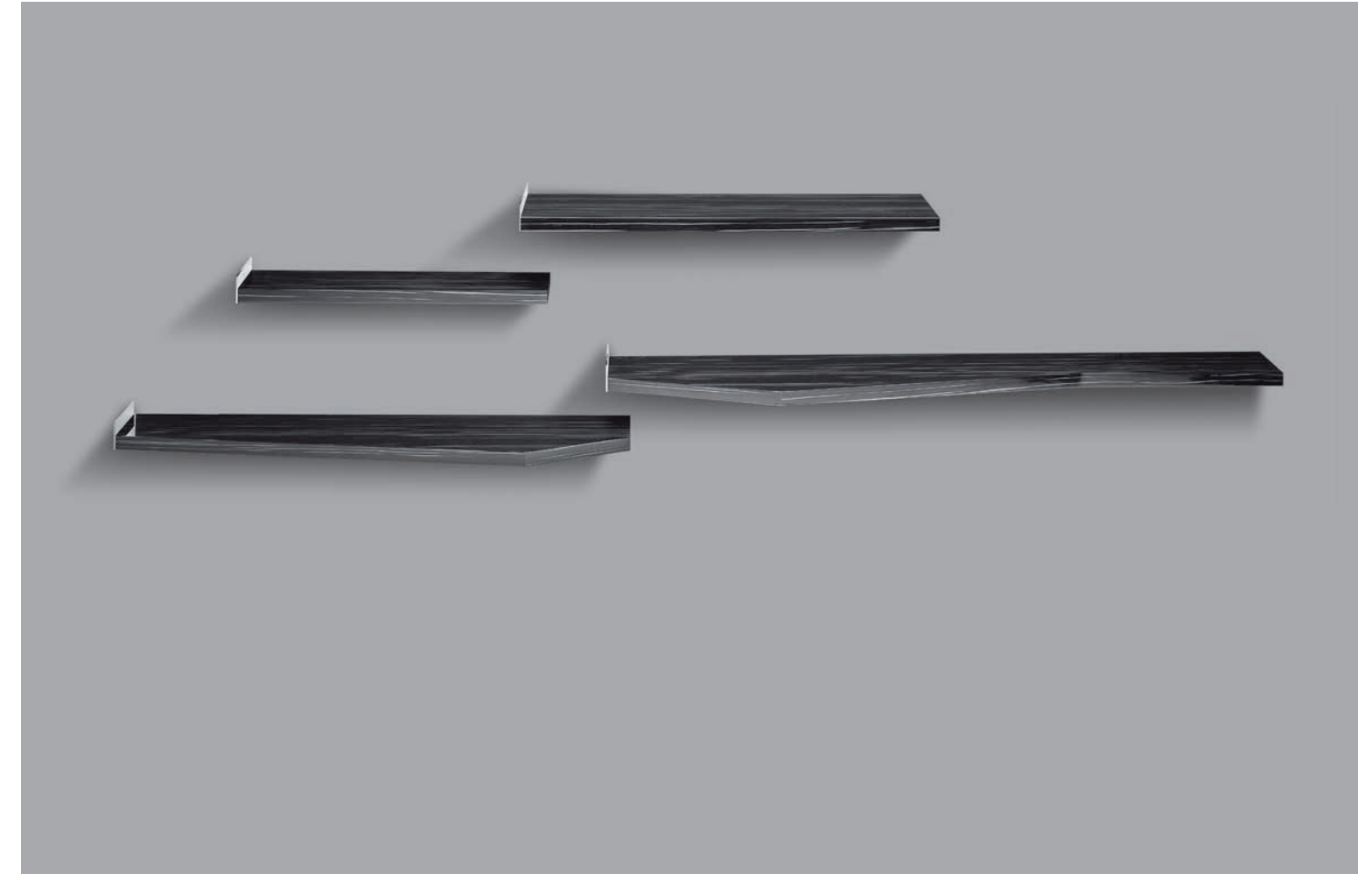
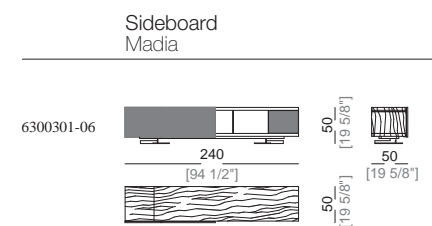

design  
Mauro Lipparini 2016

**Structure** MDF veneered in ebony, glossy ebony, moka oak or sucupira **Metal end** metal, finishes: micaceous brown, oxy grey or black nickel

**Struttura** MDF impiallacciato in ebano, ebano lucido, rovere moka o sucupira **Spondina** metallo, finiture: marrone micaceo, oxy grey o black nickel

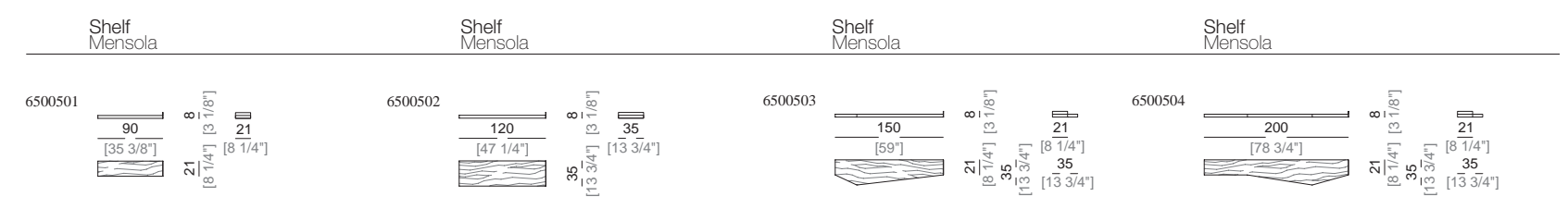

# GLORY



design  
Manzoni & Tapinassi 2014

**Top and structure** MDF veneered in Canaletto walnut, moka oak or sucupira **Metal parts in view** metal: micaceous brown, titanium or brass **Doors** wood covered with leather Pelle Leonardo

**Piano e struttura** MDF impiallacciato noce Canaletto, rovere moka o sucupira **Parti metalliche a vista** metallo: marrone micaceo, titanio o ottone **Ante** legno rivestito in Pelle Leonardo

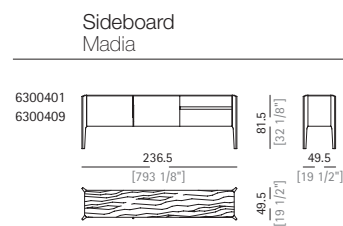

# GLORY



design  
Manzoni & Tapinassi 2014

**Top and structure** MDF veneered in Canaletto walnut, moka oak or sucupira **Metal parts in view** metal: micaceous brown, titanium or brass **Doors** wood covered with leather Pelle Leonardo

**Piano e struttura** MDF impiallacciato noce Canaletto, rovere moka o sucupira **Parti metalliche a vista** metallo: marrone micaceo, titanio o ottone **Ante** legno rivestito in Pelle Leonardo

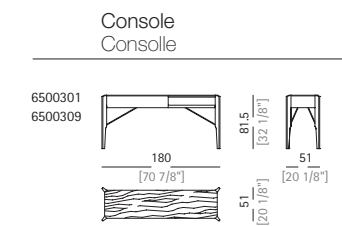

# LADY BIRD

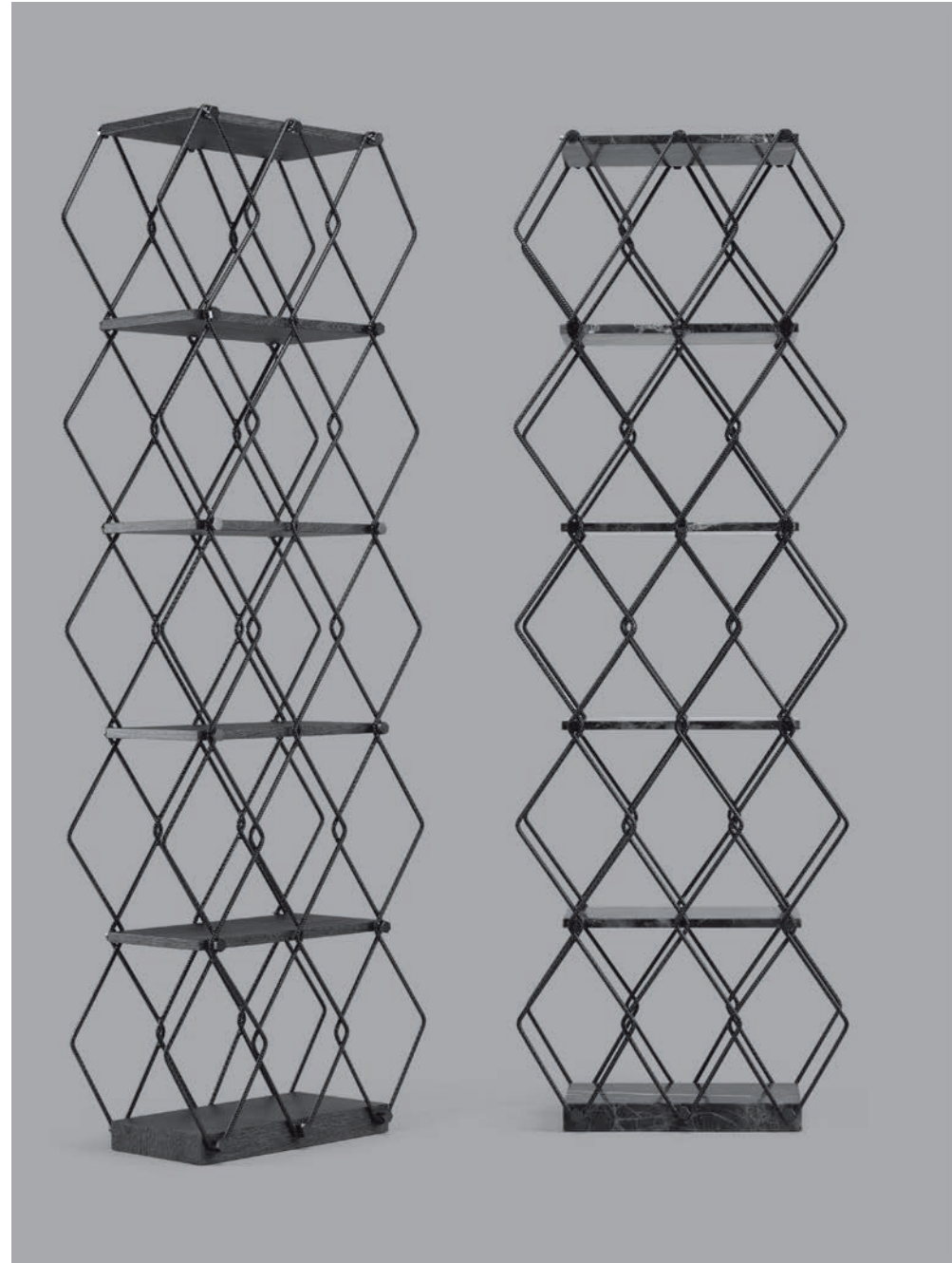

design  
Giuseppe Viganò 2014

**Structure** iron rod raw metal **Cup nuts (retainer for shelves)** brass or titanium **Shelves** Emperador marble or wood veneered in Canaletto walnut, moka oak or sucupira. The bookshelf must be fixed to the wall with the supplied screws

**Struttura** tondino in ferro verniciato grezzo **Dadi (ferma ripiani)** metallo, titanio o ottone **Ripiani** marmo Emperador o legno truciolare impiallacciato noce Canaletto, rovere moka o sucupira. La libreria deve essere fissata alla parete mediante la ferramenta in dotazione

Bookshelf  
Libreria

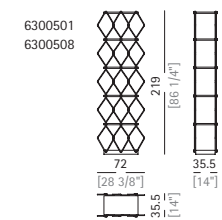

# TARGET

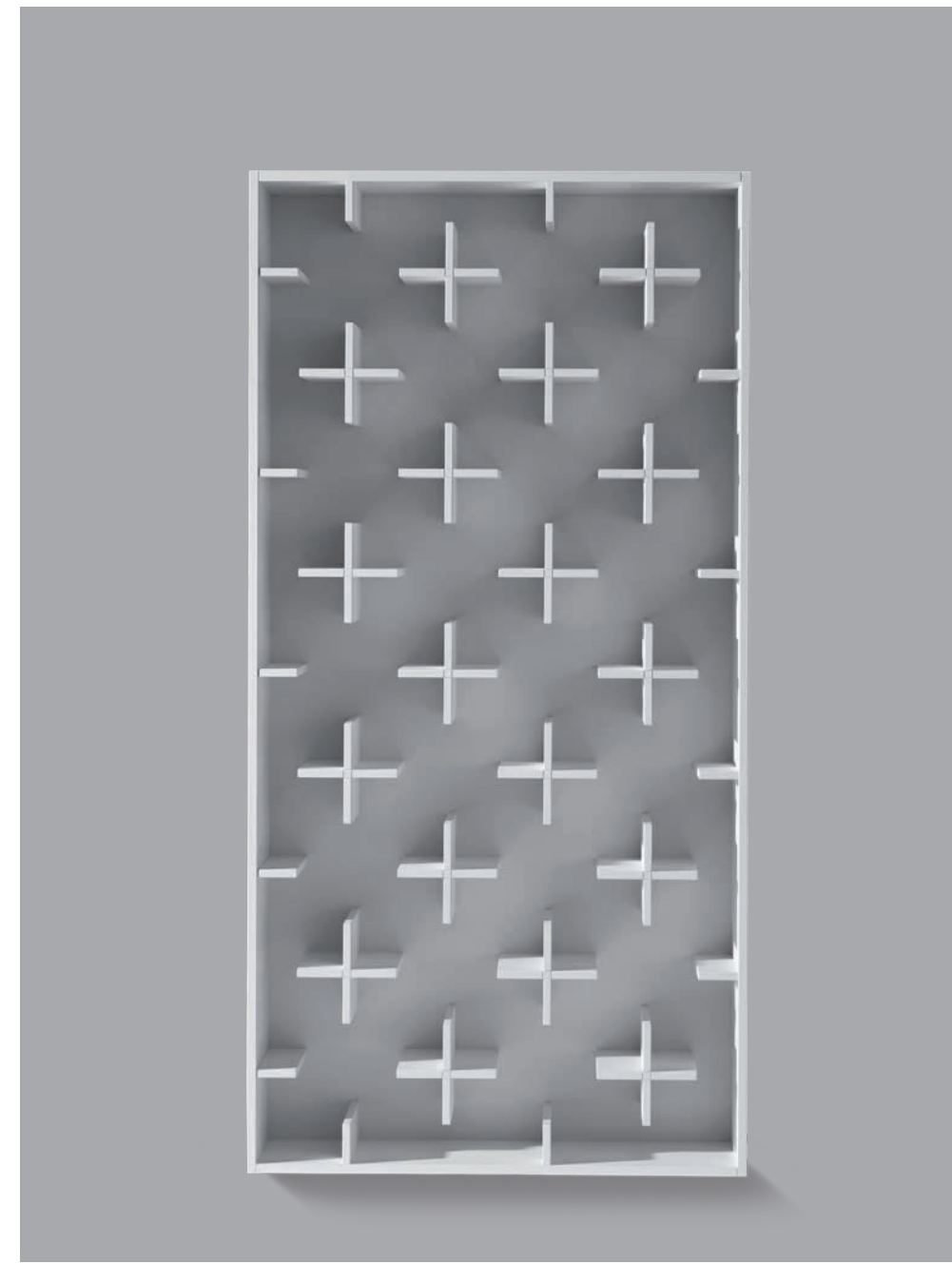

design  
Nendo 2009

**Structure** panels in MDF. Varnishing: polyurethane base with lightly embossed lacquered surface **Colours** white RAL9003 and beige Pantone 7529C. The bookshelf must be fixed to the wall with the supplied screws

**Struttura** pannelli in MDF. Fondo poliuretano e finitura in laccato macroter **Colori** bianco RAL9003 e beige Pantone 7529C. La libreria deve essere fissata alla parete mediante la ferramenta in dotazione

Bookshelf  
Libreria

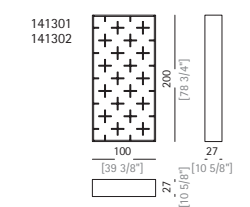

# INKIOSTRO



design  
Manzoni & Tapinassi 2013

**Structure** MDF veneered in Canaletto walnut, moka oak or sucupira wood. Vertical panels stained beige Pantone 7529C. Drawn metal, finishes: micaceous brown, titanium or brass **Top** pad cover in leatherette: white, dark brown, liquorice and black or in leather Pelle Leonardo or in leather Dirt and Tribe. **Feet** ash wood, Canaletto walnut, moka oak or sucupira

**Struttura** MDF impiallacciato noce Canaletto, rovere moka o sucupira. Divisori verticali verniciati colore beige (Pantone 7529C). Trafilato in metallo finiture: marrone micaceo, titanio o ottone **Piano** pad rivestito in cuoietto: bianco, testa di moro, liquirizia e nero o in Pelle Leonardo o in cuoio Dirt e Tribe **Piedi** frassino tinto noce Canaletto, rovere moka o sucupira

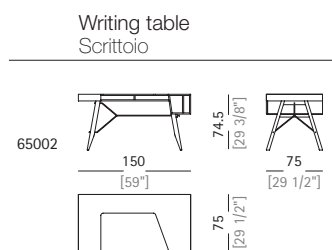

# IRIDE

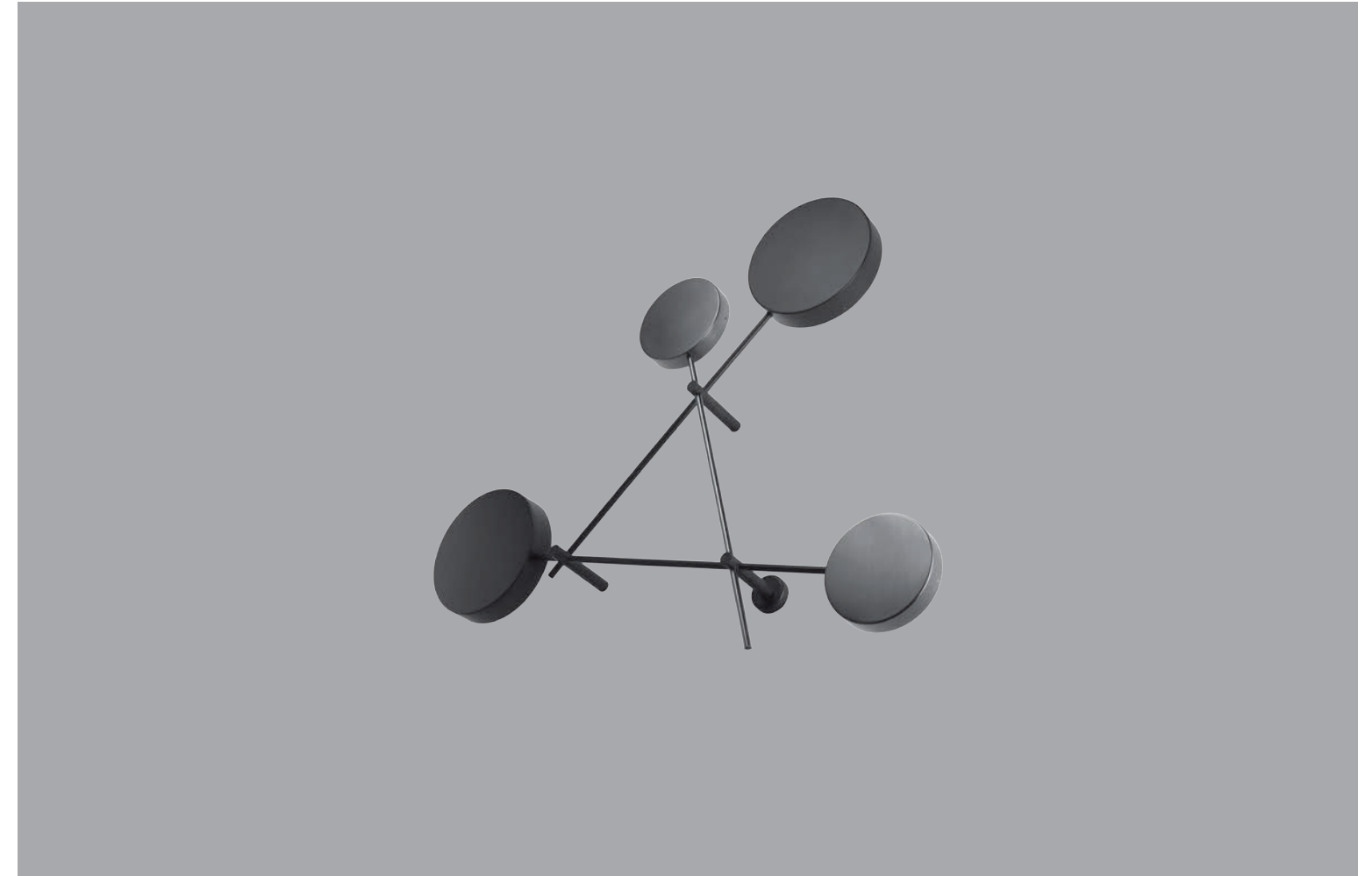

design  
Bernhardt & Vella 2015

**Structure** metal, finishes micaceous brown and titanium **Lampshades** metal discs, finishes micaceous brown and titanium, these are indicated in grey in the picture. LED lighting with dimmer.

**Struttura** metallo, finitura marrone micaceo e titanio **Paralumi** dischi di metallo verniciato colori marrone micaceo e titanio, questi ultimi indicati in grigio nel disegno. Illuminazione a LED con dimmer.

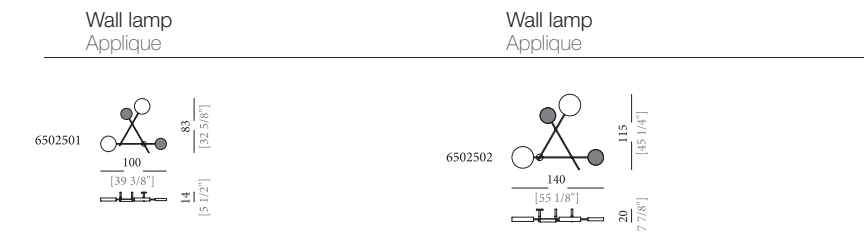

# BLOB



design  
Gino Carollo 2013

**Stem of floor and table lamp** metal, finishes: micaceous brown, brass or titanium **Structure of suspension** steel cables, rose and cylinder for cables in metal, finishes: micaceous brown, brass or titanium **Lampshades** bronze or grey glass outside and white inside. Cable at sight available in red and grey. Lamp holder E27, bulb 23W

**Struttura** lampada da terra e tavolo metallo, finiture: marrone micaceo, ottone o titanio **Struttura** lampada a sospensione cavi in acciaio, rosone e cilindro passaggio cavi in metallo, finiture: marrone micaceo, ottone o titanio **Paralumi** vetro nei colori bronzo o grigio nella parte esterna e bianco internamente. Cavo a vista nei colori rosso e grigio. Attacco E27, lampadine 23W

# OOMPA-LOOMPA



design  
Gino Carollo 2015

**Structure** metal, finishes micaceous brown or titanium **Lampshades** glass, colours ruby red, aquamarine blue or bronze. **Cable in view** white and black. Floor lamp and suspension Ø32 cm no. 3 lamp holders E14 for bulbs 40W Suspension Ø41 cm no. 1 lamp holder E27 for bulb 60W Suspension Ø58 cm no. 3 lamp holders E27 for bulbs 60W **Attention** bulbs not included

**Struttura** metallo, finiture marrone micaceo o titanio **Paralumi** vetro nei colori rosso rubino, celeste acquamarina o bronzo **Cavo a vista** colore bianco e nero. Lampada da terra e lampada a sospensione Ø32 cm n. 3 attacchi E14 per lampadine 40W Lampada a sospensione Ø41 cm n. 1 attacco E27 per lampadina 60W Lampada a sospensione Ø58 cm n. 3 attacchi E27 per lampadine 60W **Attenzione** lampadine non incluse

Suspension  
Lampada a sospensione

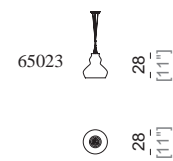
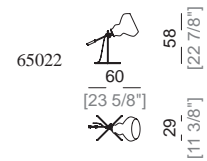
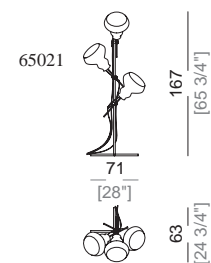

Table lamp  
Lampada da tavolo



Floor lamp  
Lampada da terra



Suspension  
Sospensione

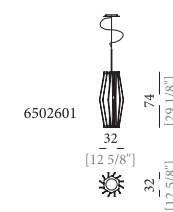

Suspension  
Sospensione

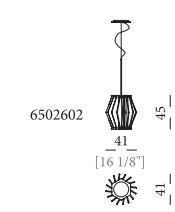

Suspension  
Sospensione

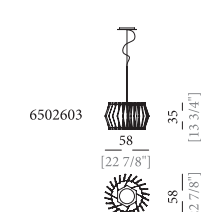

Floor lamp  
Lampada da terra

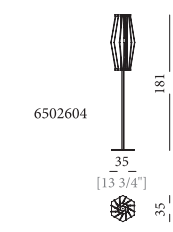

# WUDÙ



design  
Studio Arketipo 2013

**Suspension: Lampshade** in fabric collection Camisia. They can be ordered in any quantity only in fabrics D/4677 and D/4678 collection Camisia. For all the other colours the minimum quantity per order is of 3 pieces or multiple of 3. The suspension is supplied with 2 m cable covered with linen and 1 energy saving lamp 53W  
**Floor lamp: Base** Emperador marble **Stem** metal, finishes: micaceous brown, titanium or brass **Lampshade** in fabric collection Camisia. Bulb 53W

**Lampada a sospensione: Paralume** in tessuto collezione Camisia. Il colore D/4677 e D/4678 della collezione Camisia non è soggetto a limitazioni di numero. Per tutte le altre varianti colore possiamo accettare solo ordini corrispondenti a multipli di tre. La lampada viene fornita di 2 m di cavo rivestito in lino grezzo e di una lampadina a basso consumo da 53W

**Lampada da terra: Base** marmo Emperador **Struttura** metallo, finiture: marrone micaceo, ottone o titanio **Paralume** in tessuto collezione Camisia. Lampadina 53W

Suspension  
Lampada a sospensione

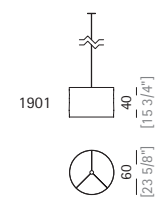

Floor lamp  
Lampada da terra

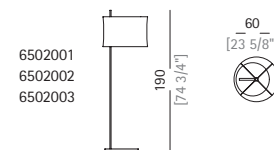

# CUBO



design  
Massimo Lorusso 2006

**Structure** wood **Upholstery** non-deformable polyurethane D32 covered with coupled synthetic lining 6 mm **Feet** plastic feet, h. 2 cm

**Struttura** legno **Imbottitura** poliuretano indeformabile D32 con fodera di vellutino accoppiato 6 mm **Piedi** plastica, h. 2 cm

Pouf  
Pouf

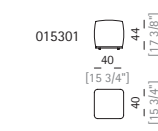

Pouf  
Pouf

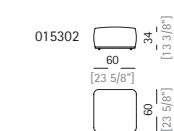

# VANITY FAIR



design  
Gino Carollo 2014

**Structure** metal sheet covered with leather or velvet collection Vellù **Mirror** single mirror: mirrored or mirrored smoked glass. Double and triple mirror: mirrored smoked glass with inserts in mirrored glass

**Struttura** lamiera di metallo rivestita in Pelle o in velluto collezione Vellù **Specchio** cristallo specchiato o cristallo specchiato fumè nella versione singola. Cristallo specchiato fumè con inserti in cristallo specchiato nella versione doppia e tripla

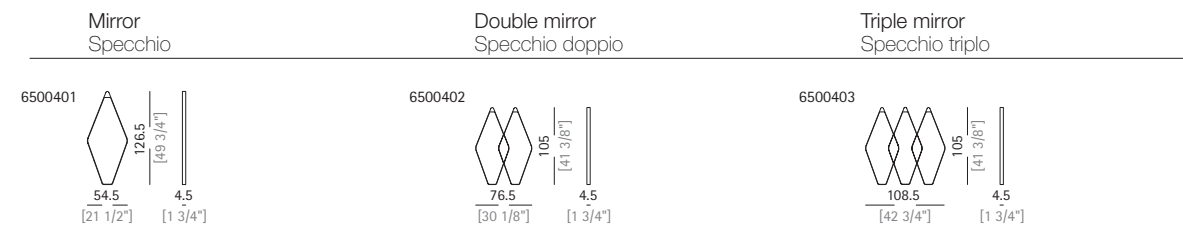

# JEDIZ

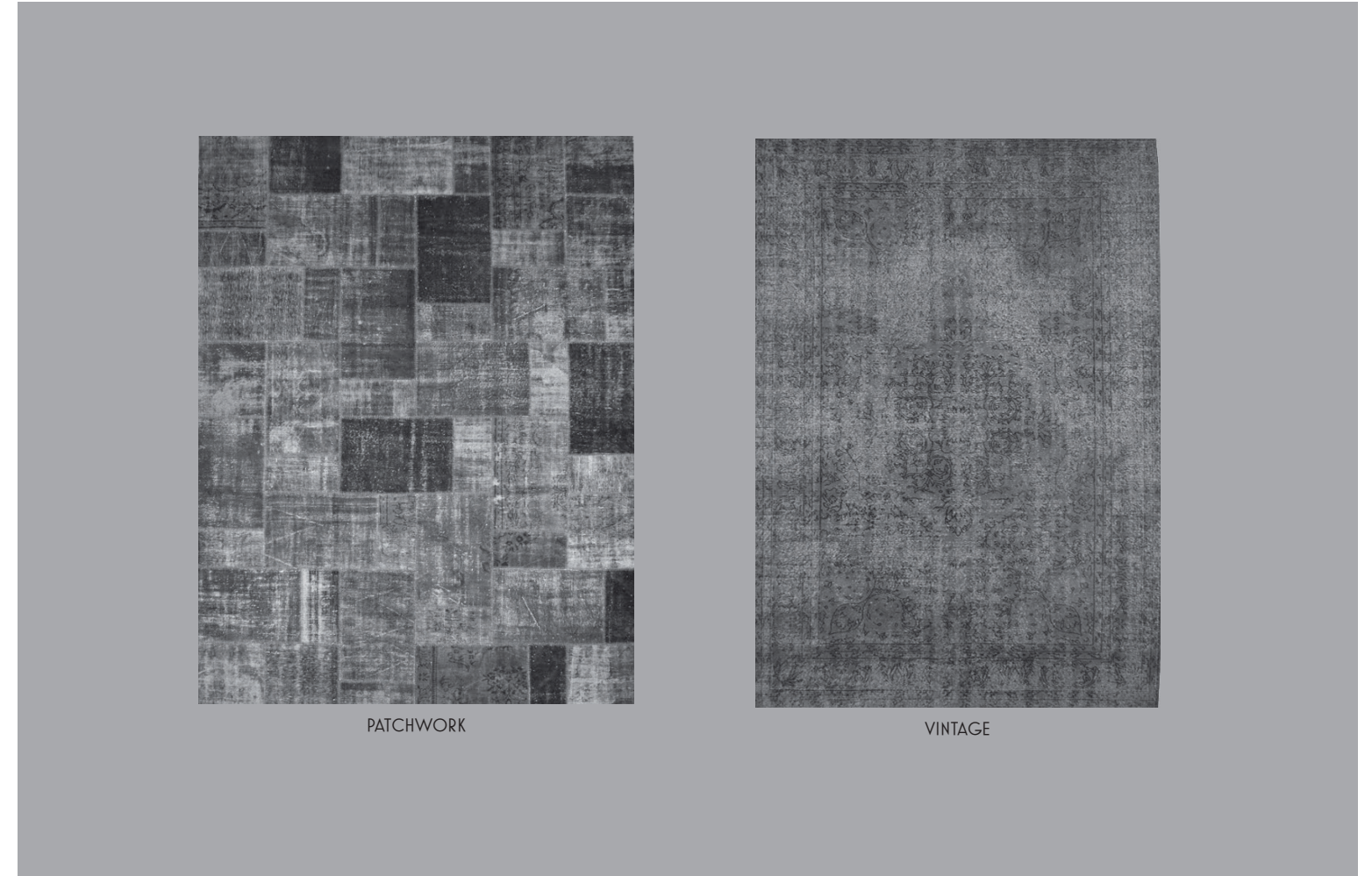

The Patchwork carpets are created using old damaged Oriental carpets. Once removed the damaged parts, they are coloured, cut in square pieces and then sewn again. The result is a piece unique in design, size and colour. The Vintage collection is the contemporary reinterpretation of old Oriental carpets, preserving the charm of the antique hand knotted pieces. They are unique pieces and dimensions vary depending on the original size. The colour intensity depends on the kind of wool used in the original carpet and the colour range goes from classic to more vivid shades.

I tappeti Patchwork sono creati utilizzando tappeti orientali antichi molto usurati. Dopo le operazioni di scelta e tintura, vengono tagliati e riassemblati da mani esperte, dando vita a risultati sempre diversi, nel rispetto dei materiali originali. I tappeti Vintage sono il restyling moderno di tappeti orientali antichi annodati a mano. Tutti i pezzi sono unici e le misure variano a seconda delle dimensioni del tappeto originale. I toni spaziano dai più classici fino a tonalità più accese; l'intensità dei colori varia in base al tipo di lana utilizzata per il tappeto d'origine.

# MATERIALS – MATERIALI

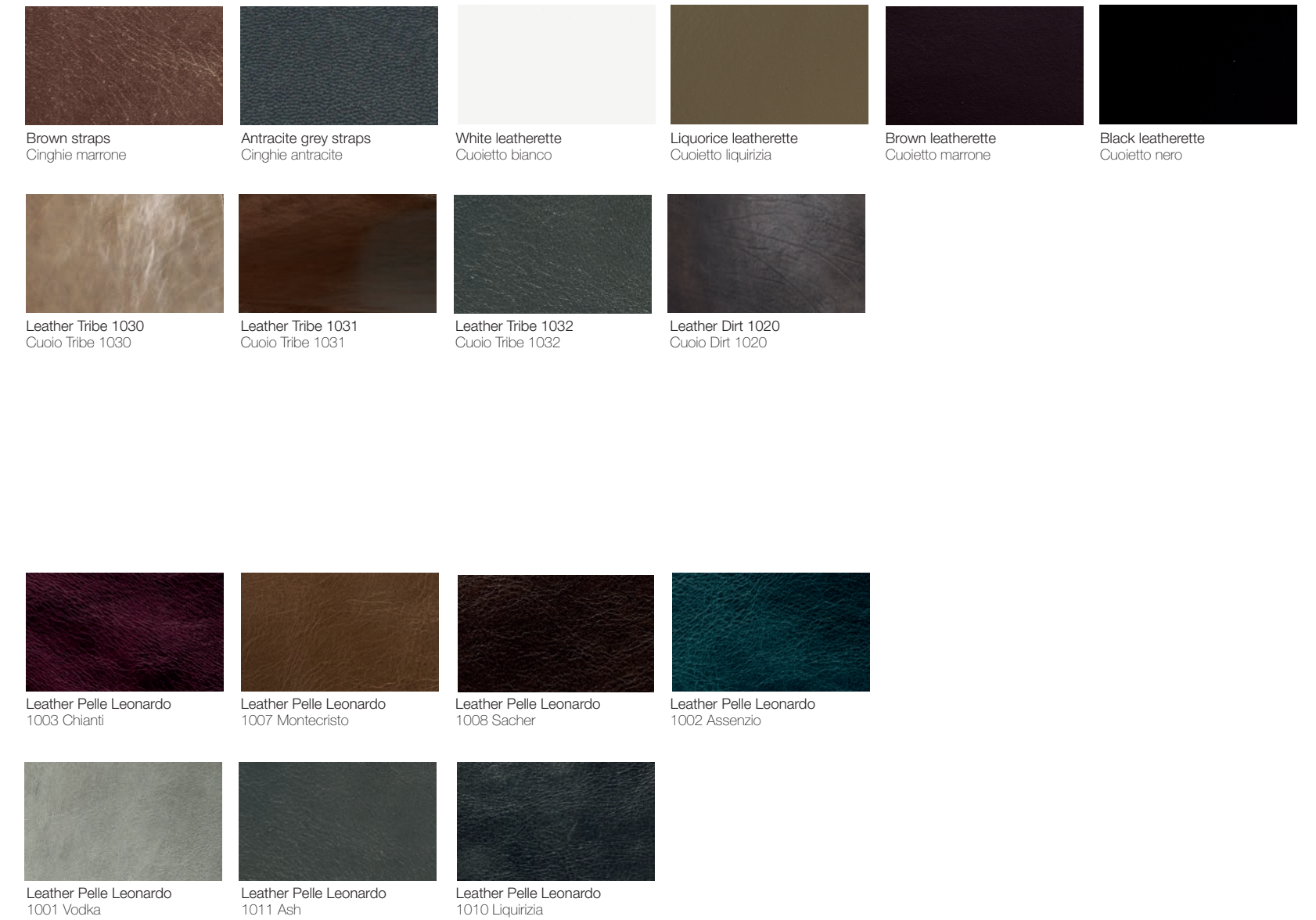
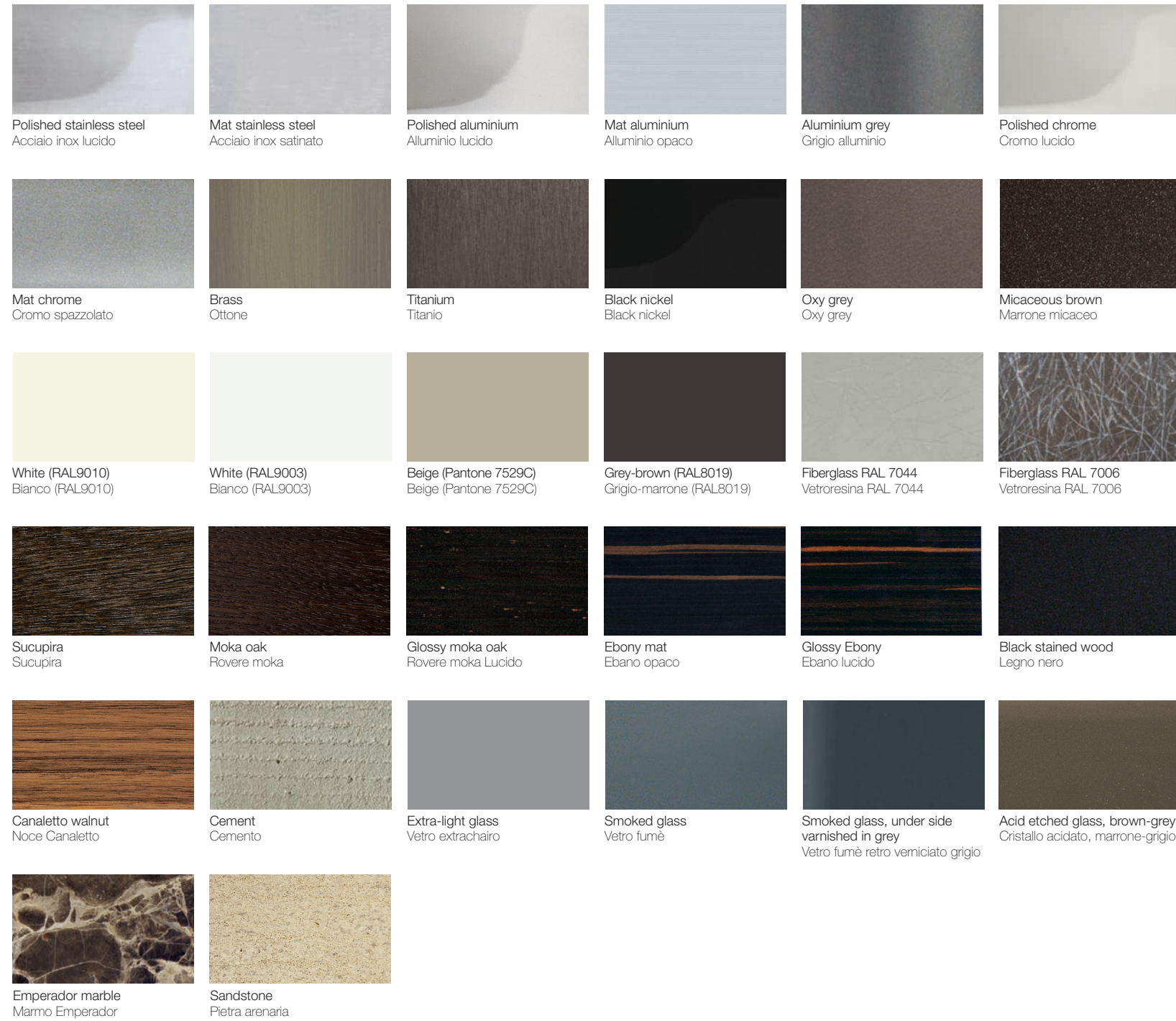

# ZIP AND GROSGRAIN COLOUR CHART – COLORI CERNIERE E GROS-GRAIN





## CUSHIONS – CUSCINI



Print

Damasco

Ricamo/Fiore

Scubidù

Armchusion  
Cuscino bracciolo

Armchusion  
Cuscino bracciolo

Armchusion  
Cuscino bracciolo

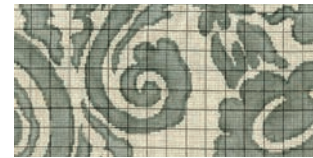
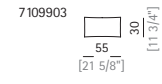
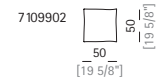
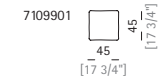

Print grigio 02

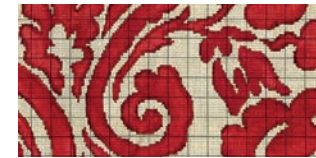

Print rosso 03



Print beige 01



Damasco azzurro 3



Damasco marrone 4



Ricamo/Fiore



Scubidù 01



Scubidù 11



Scubidù 10

## DOUBLEFACE CUSHIONS – CUSCINI



Armchusion side A leather, side B fabric.  
Cuscino bracciolo lato A pelle, lato B tessuto.

Armchusion  
Cuscino bracciolo

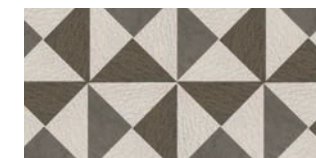
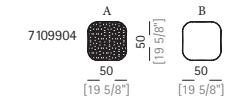

Lato A / Side A  
Pelle B 3110, 3111, 3150

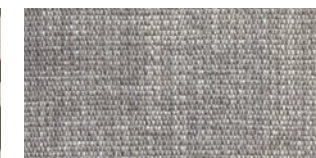

Lato B / Side B  
Taiga D/4838

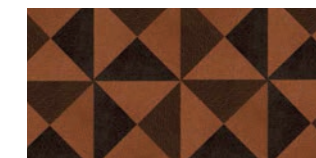

Lato A / Side A  
Pelle B 3101, 3102, 3103



Lato B / Side B  
Camisia D/4681



arketipo srl

via Garibaldi, 84/86  
50041 Calenzano (Firenze)  
phone +39 0558876248  
fax +39 0558873429  
info@arketipo.com  
export@arketipo.com

[arketipo.com](http://arketipo.com)

