



atmosfera suggestive
stile contemporaneo
gusto esotico





COME NASCE UN SOGNO

GIO' STEMAR nasce per realizzare un sogno. Un sogno nato da un'idea che si fa progetto per diventare realtà. Un sogno che si fa materia rispettando rigorosi parametri di qualità.

Realizziamo un prodotto innovativo dando vita al vostro sogno, a qualcosa di unico che va oltre gli schemi canonici per mezzo di materiali naturali provenienti da tutto il mondo e prodotti tecnologici rispettosi dell'ambiente.

GIO' STEMAR è ecosostenibilità ed ecocompatibilità realmente applicate! Progettiamo e arrediamo i vostri spazi con i giusti accorgimenti tecnico/funzionali per renderli vivi, accoglienti e unici utilizzando i migliori prodotti che Madre Natura offre.

Dallo stabilimento balneare (di cui siamo promotori), al villaggio turistico, alla piscina dell'albergo, all'agriturismo, al B&B, ma anche al giardino di casa, GIO' STEMAR è in grado di dare quel giusto tocco esotico per fare del tuo spazio un luogo affascinante, confortevole e ospitale.

Progettazione dello spazio e armonia dei prodotti scelti con cura e studiati su misura, con severa selezione dei materiali sono i nostri principali servizi che offriamo forti della nostra esperienza e grazie al nostro staff di tecnici e architetti in grado di soddisfare ogni desiderio e, soprattutto, ogni sogno!

A DREAM IS BORN

GIO'STEMAR makes your dreams come true. Dreams born of ideas that become a project that turns into reality.

Dreams that become visible and tangible and meet rigorous quality standards.

We manufacture innovative products to make your dreams come true. We can give shape to something unique that goes beyond the usual patterns using natural materials sourced all over the world and eco-friendly technological products.

GIO'STEMAR is sustainability and environment-friendliness at work! We design and furnish your space according to the right functional and technical mastery, with ingenuity to make them come alive, welcoming and unique using the best products Mother Nature provides.

From the bathhouse to the resort, to the hotel swimming pool, the farm holiday house, the B&B, but also for your home garden, GIO'STEMAR can give that perfect exotic touch to make any space striking, charming, comfortable and welcoming.

Location design and carefully chosen products, studied and customized after rigorous selection of the materials are the main services we provide, confident because of our experience and thanks to our staff of architects and skilled technicians who can satisfy any wish and, most importantly, any dream!

LA NAISSANCE D'UN RÊVE

GIO'STEMAR réalise vos rêves. Rêves qui naissent comme une idée qui devient conception pour atteindre la réalité.

Rêves qui deviennent matière en respectant des paramètres de qualité rigoureux.

Nous réalisons un produit innovateur pour transformer vos rêves en réalité, quelque chose d'unique qui dépasse les schémas canoniques en utilisant des matériaux naturels qui viennent du monde entier avec produits technologiques respectueux de l'environnement.

GIO'STEMAR est durabilité environnementale et écoconception réellement appliquées! Nous concevons et meublons vos espaces avec les meilleurs systèmes techniques et fonctionnels pour les rendre vifs, accueillants et uniques en utilisant les meilleurs produits que Mère Nature offre.

De l'établissement balnéaire au village de vacances, à la piscine de l'hôtel, au gîte rural, au B&B, mais aussi pour votre jardin, GIO'STEMAR est à même de donner la touche exotique parfaite pour faire de votre espace un lieu charmant, confortable et accueillant.

Conception de l'espace et produits choisis avec soin, étudiés et personnalisés après une sévère sélection des matériaux, sont les services principaux que nous offrons, forts de notre expérience et grâce à notre équipe de techniciens et architectes capables qui sont à même de satisfaire toute exigence et, ce qui est le plus important, tout rêve!

INDICE

- | | | | |
|--------------|---|--------------|---|
| 4/5 | Canna Africana
Cape Reed
Roseau African | 28/29 | Stile Africa |
| 6/7 | Canna Africana xl
Cape Reed xl
Roseau African xl | 30/31 | Java |
| 8/9 | St Bali | 32/33 | Cabina
Cabin
Cabine |
| 10/11 | Esotic | 34/35 | Chioschi Modulari
Modular Kiosks
Kiosques Modulaires |
| 12/13 | Makuti | 36/41 | Chioschi Modulari
Modular Kiosks
Kiosques Modulaires
MADE IN ITALY |
| 14/15 | Alang Alang | 42/43 | Chioschi e Chiringuitos
Kiosks and Chiringuitos
Kiosques et Chiringuitos |
| 16/17 | Erba Palustre
Marsh Grass
Herbe des Marais | 44/47 | Composizioni
Compositions |
| 18/19 | Canna Africana Mix
Cape Reed Natural
and Synthetic Mix
Roseau Africain Mix
Synthetique Naturel | 48/65 | Arredo e complementi
Furniture and accessories
Ameublement et accessoires |
| 20/21 | Palma Sintetica Gialla
Synthetic Palm Yellow
Palmier Synthetique Jaune | 66/67 | Suite Bamboo
Bamboo Suite
Suite Bambou |
| 22/23 | Palma Sintetica
Marrone/Grigio
Synthetic Palm Brown/Gray
Palm Synthetique Marron/Gris | 68/71 | Gazebo |
| 24/25 | Palma Sintetica
Bianco/Grigio
Synthetic Palm White/Gray
Palm Synthetique Blanc/Gris | 72/75 | Costruzioni
Constructions
Construction |
| 26/27 | Makuti Sintetico
Synthetic Makuti
Makuti Synthetique | 76/79 | Dimensioni
Dimensions |

CANNA AFRICANA

Coperture di varie dimensioni e forme, realizzate con tegole in canna africana cm 80x45: un prodotto naturale ed ecologico proveniente dall'Africa meridionale. Materiale ideale in zone ventose, necessita di scarsa manutenzione. Sono disponibili diverse soluzioni, varie dimensioni, colorazioni a scelta del cliente, anche con guaina interna per offrire maggiore resistenza all'acqua.



CAPE REED

Coverings in different shapes and sizes made with Cape reed slats cm 80x45: a natural and eco-friendly product from southern Africa.

Ideal for windy areas and low-maintenance, too.

Various solutions available, various sizes, choice of colours and we can also provide them with an inner insulating sheath for improved water resistance.



ROSEAU AFRICAIN

Couvertures en formes et dimensions différentes faites avec le roseau africain, chaume du Cap cm 80x45 : un produit naturel et écologique venant d'Afrique du sud.

Matériau idéal pour les zones venteuses, nécessite de peu d'entretien. Il existe plusieurs solutions, plusieurs dimensions, couleurs au choix du client et aussi avec gaine interne pour une plus grande résistance à l'eau.



CANNA AFRICANA XL



Coperture di varie forme e dimensioni realizzate con tegole in canna africana di lunghezza maggiore, cm 80x75, rispetto allo standard. Le diverse dimensioni della tegola non incidono sulla caratteristica principale del prodotto: la resistenza al vento.

CAPE REED XL

Cape reed coverings in various shapes and sizes of longer size, cm 80x75, compared to usual standards. The larger size does not affect the main characteristic of the product: wind resistance.





ROSEAU AFRICAN XL

Couvertures de différentes formes et dimensions réalisées avec tuiles en roseau africain, chaume du Cap, de longueur supérieure, cm 80x75, au standard. La taille plus grande n'affecte pas la caractéristique principale du produit: la résistance au vent.

ST BALI

Coperture rotonde o rettangolari di diverse dimensioni realizzate intrecciando un filamento d'erba naturale.

Di facilissima collocazione sugli ombrelloni: basta appoggiare la copertura sulla struttura portante, senza necessità di agganci.

Garantisce ottima stabilità anche in zone ventose.



Round or rectangular coverings made with natural braided grass blades. Very easy to set on sun umbrellas: simply place the cover onto the load bearing structure, without any need for fastening. Optimum stability guaranteed even in windy areas.

Couvertures rondes ou rectangulaires en plusieurs dimensions faites à partir de filaments d'herbe naturelle tressée. Très facile à installer sur les parasols: il suffit de poser la couverture sur la structure porteuse sans besoin d'accrochage. Stabilité optimale garantie même en zones venteuses.



ESOTIC

Coperture rotonde disponibili in varie dimensioni, ideali per ombrelloni, per una scelta di stile hawaiano. Disponibili anche pannelli quadrati, idonei a ogni copertura. Sovrapposti e in buona pendenza migliorano il deflusso d'acqua in caso di pioggia.

Round coverings in various sizes, ideal for sun umbrellas, for a Hawaiian style choice. Also available as square panels, suitable for any type of covering. Overlay and set at steep slant to improve water outflow.





Couvertures rondes en plusieurs dimensions, idéales pour les parasols, pour un choix de style hawaïen. Disponibles aussi en panneaux carrés, adaptés pour toute sorte de couverture. Superposées avec un angle important elles améliorent la sortie d'eau.



MAKUTI

Copertura in foglie di palma africana, disponibile in rotoli o tegole, ideali per la realizzazione di ombrelloni da spiaggia e coperture. A differenza di quello asiatico, il makuti che adoperiamo è più resistente, più flessibile e più duraturo.



African coconut palm leaf thatch covering, available in rolls or slats, ideal for beach sun umbrellas and general covers. Unlike the Asian variety, African makuti is our material of choice for its superior resistance, flexibility and lifespan.

Couverture en feuilles de palmier africain, disponible en rouleaux cm 500x70 et tuiles, parfaite pour les parasols et les couvertures préexistantes.



ALANG ALANG

Copertura in paglia naturale, disponibile in rotoli cm 450x70, ideali per rivestire ombrelloni e strutture preesistenti.





Straw sun umbrella, reed covers, also available as rolls cm 450x70, ideal for sun umbrella covers and pre-existing structures.

Couvertures en paille naturelle, chaume, disponible en rouleaux cm 450x700, parfaites pour le revêtement des parasols et des structure préexistantes.



ERBA PALUSTRE

Copertura a forma di rotolo cm 190x70 realizzato con materiale naturale simile all'erba palustre rilegato su corda *vine*.



MARSH GRASS

Roll coverings cm 190x70 of natural material similar to marsh grass bound with vine rope.

HERBE DES MARAIS

Couverture en rouleau cm 190x70 en matériau naturel similaire à l'herbe palustre, reliée sur corde de vigne.

CANNA AFRICANA MIX

Tegola cm 80x45 con una parte sintetica che non necessita di manutenzione, impiegata soprattutto su costruzioni definitive, dall'aspetto della tradizionale canna africana, ma dalla durata superiore. Può essere applicata sia con le classiche clips su tondini diametro 8 mm o fissata direttamente tramite viti/chiodi.



CAPE REED NATURAL AND SYNTHETIC MIX

Synthetic mix tile cm 80x45, no maintenance, used mainly for final constructions, African reed look and superior life. Can be set with clips onto Ø 8mm rods or fixed directly with screws/nails.



ROSEAU AFRICAIN MIX SYNTHETIQUE NATUREL

Tuile mix synthétique cm 80x45, aucun entretien, utilisée surtout pour les constructions finales, aspect de roseau africain, durée supérieure. Peut être appliquée avec des clips sur tige Ø 8mm ou fixée directement avec vis/clous.

PALMA SINTETICA GIALLA

Tegole cm 80x60 di foglie di palma sintetiche (gialle) dall'aspetto naturale di foglie, dotate di clips per il fissaggio.





SYNTHETIC PALM YELLOW

Synthetic yellow palm leaves slats cm 80x60 that look like natural leaves with clips.

PALMIER SYNTHETIQUE JAUNE

Tuiles en feuilles de palmier synthétique jaunes à l'aspect de feuilles naturelles, clips de fixation fournis.

PALMA SINTETICA MARRONE/ GRIGIO

Tegole cm 80x60 di foglie di palma sintetiche (marrone/grigio) dall'aspetto naturale di foglie, dotate di clips per il fissaggio.





SYNTHETIC PALM BROWN/GRAY

Synthetic brown/grey palm leaves slats cm 80x60 that look like natural leaves with clips.

PALMIER SYNTHETIQUE MARRON/GRIS

Tuiles en feuilles de palmier synthétique marron/gris à l'aspect de feuilles naturelles, clips de fixation fournis.

PALMA SINTETICA BIANCO/GRIGIO

Tegole cm 80x60 di foglie di palma sintetiche (bianco/grigio)
dall'aspetto naturale di foglie, dotate di clips per il fissaggio.





**SYNTHETIC PALM
WHITE/GRAY**

Synthetic white/grey palm leaves slats cm 80x60 that look like natural leaves with clips.

**PALMIER SYNTHETIQUE
BLANC/GRIS**

Tuiles en feuilles de palmier synthétique blanc/gris à l'aspect de feuilles naturelles, clips de fixation fournis.



MAKUTI SINTETICO

Coperture a tegole cm 100x60, complete di asta rigida.
Garantisce alta resistenza agli agenti atmosferici e rende impermeabile, con elevate pendenze, i tetti delle costruzioni.
Durata e garanzia superiori a quelle dei prodotti naturali.



SYNTHETIC MAKUTI

Slat covering cm 100x60, complete with rigid shaft. High resistance to weathering and, when set with a steep slant, waterproofs construction roofs. Superior life and guarantee compared to natural products.



MAKUTI SYNTHETIQUE

Tuiles de couverture cm 100x60 avec tige rigide. Grande résistance aux agents atmosphériques et placé avec un angle important, rend imperméable le toit des constructions. Durée et garantie supérieures par rapport aux produits naturels.





STILE AFRICA

Tegola sintetica Stile Africa disponibile senza clips da fissare su perlinati e con clips da fissare su ombrelloni; indistinguibile dalle classiche coperture in paglia palustre.



Stile Africa synthetic slat without clips to fix onto match boarding and with clips for sun umbrellas.



Stile Africa tuile synthétique avec clips de fixation sur lambris et avec clips pour les parasols.



JAVA

Tegola Java cm 80x50 in materiale sintetico dall'aspetto naturale di foglie, dotata di clips per il fissaggio.

Disponibile anche la versione dallo spessore ridotto, cm 80x40, ideale per il rivestimento e le coperture delle costruzioni.





Synthetic Java slat cm 8x50 that look like natural leaves with clips. A reduced thickness version, cm 80x40, is also available and ideal for cladding and construction coverings.

Tuile Java synthétique à l'aspect de feuilles naturelles, clips de fixation fournis.
Une version à épaisseur réduite cm 80x40 est aussi disponible, idéale pour revêtements et couvertures de constructions.



CABINA

Cabina in legno di pino autoclavato completa di pedana e panchina interna, porta con maniglia e tetto monofalda.



CABIN

Autoclaved pine wood hut with footboard and bench, door with handle and single-pitch roof.



CABINE

Cabine en sapin autoclavé avec marche-pied et banquette, porte avec poignée et toit à un étage.



CHIOSCHI MODULARI

Chioschi realizzati con moduli pre-allestiti di eucalipto, bambù o legno. Si possono scegliere le forme e le dimensioni, tutte adattabili alle nostre coperture standard.



MODULAR KIOSK

Kiosks made with pre-fitted modules in eucalyptus, bamboo or wood. Shapes and sizes can be chosen, all adaptable to our standard coverings.



KIOSQUES MODULAIRES

Kiosques faites à partir de modules pré-équipés en eucalyptus, bambou ou bois. On peut choisir les formes et les dimensions, toutes adaptables à nos couvertures standard.

CHIOSCHI MODULARI

MADE IN ITALY

Chioschi realizzati con moduli Made in Italy, lato cm 150-200 completamente personalizzabili. Permettono di realizzare chioschi con forme, dimensioni, rivestimenti esterni e coperture diversi.



MODULAR KIOSK MADE IN ITALY

Kiosks made with Made in Italy modules, side cm 150-200, fully customizable to allow the realisation of kiosks of different shapes, sizes, external claddings and coverings.



KIOSQUES MODULAIRES MADE IN ITALY

Kiosques faits à partir de modules Made in Italy, côté cm 150-200, entièrement personnalisables pour réaliser des kiosques de forme, dimension, revêtements extérieurs et couvertures différents.









CHIOSCHI E CHIRINGUITOS

Chioschi/Chiringuitos realizzabili con materiali e prodotti diversi.
Tutti personalizzabili secondo le esigenze del cliente, dalla copertura
al rivestimento interno, ai pannelli per le chiusure serali.





KIOSKS AND CHIRINGUITOS

Kiosks/Chiringuitos with various products and materials, all customizable according to customers' requirements, from the covering to the internal cladding, to the panels for the nightly closure.

KIOSQUES ET CHIRINGUITOS

Kiosques/Chiringuitos avec matériaux et produits divers, personnalisables selon les exigences du client, de la couvertures au revêtement interne, aux panneaux pour la fermeture du soir.



COMPOSIZIONI

Composizioni realizzate utilizzando diversi materiali: dal tavolo (rotondo, quadrato, triangolare o rettangolare) alle docce e molto altro ancora; tutto personalizzabile con qualsiasi tipo di copertura.



COMPOSITIONS

Decors made with various materials: table (round, square, triangular or rectangular), showers and so much more. Fully customizable with any type of covering.

Décor fait avec matériaux différents : table (ronde, carrée, triangulaire ou rectangulaire), douches et bien plus encore.







ARREDO E COMPLEMENTI

Salotti, tavoli, sedie e sgabelli realizzati con i più svariati materiali naturali, provenienti da tutto il mondo.

Offriamo accessori per impreziosire interni ed esterni: dai lampadari in conchiglia alle staccionate in eucalipto o in bambù, fino ai lampioni in canna africana.





FORNITURE AND ACCESSORIES

Sitting areas, tables, chairs and stools made with the most diverse natural materials from all over the world.

We provide accessories to enhance both outdoor and indoor areas: from shell chandeliers, to eucalyptus or bamboo fences, to lampposts in African reed.



AMEUBLEMENT ET ACCESSOIRES

Salons, boudoirs, tables, chaises et tabourets faits avec les matériaux les plus divers venant de tout le monde. Nous proposons les accessoires pour valoriser vos intérieurs et vos extérieurs : des lustres en coquillage aux clôtures en eucalyptus ou bambou, jusqu'aux réverbères en roseau africain.



















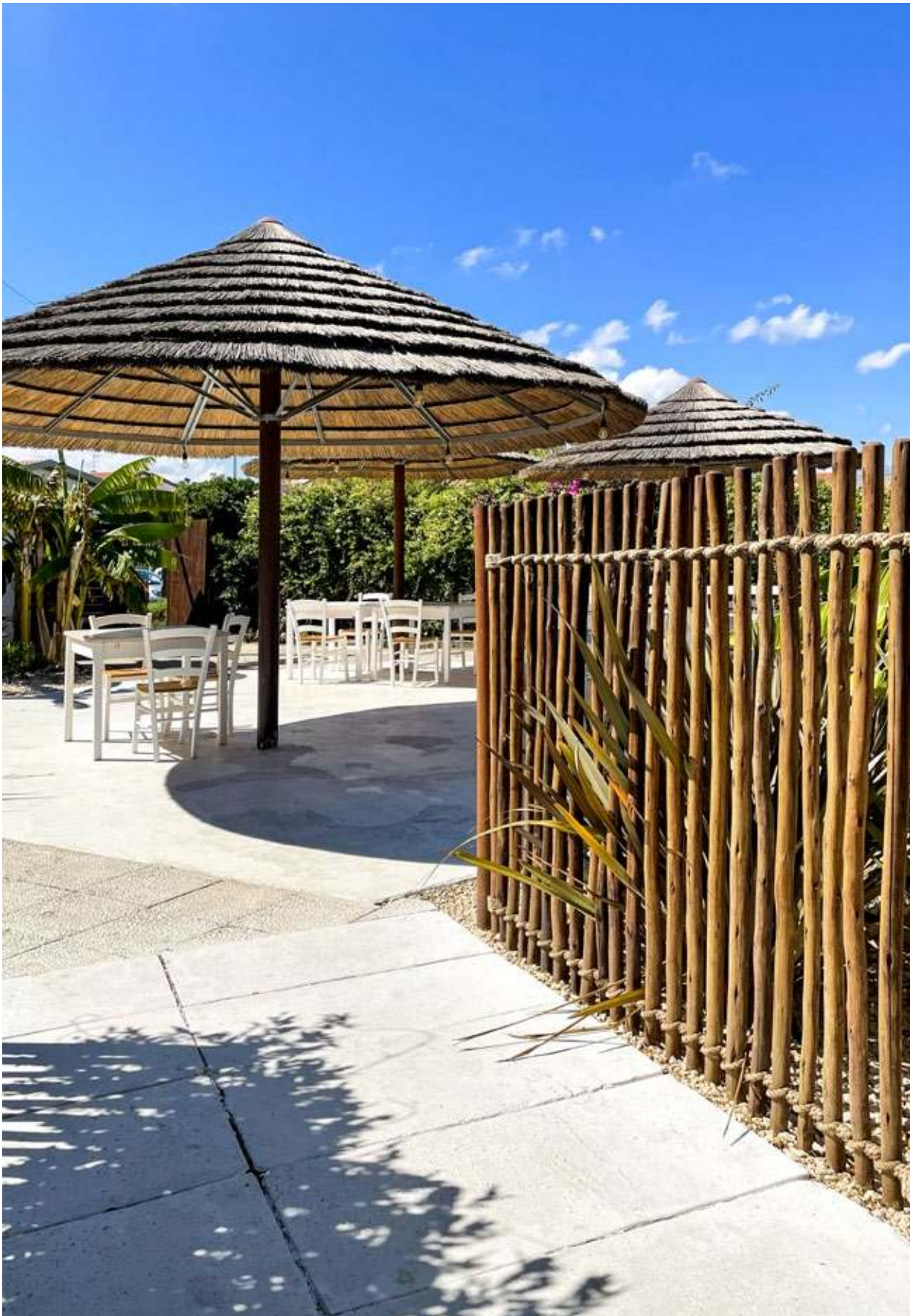













SUITE BAMBOO

Un angolo realizzato in bambù dove rilassarsi in piena tranquillità. La struttura è consegnata completa di panche e tavolo.



BAMBOO SUITE

A bamboo corner for maximum relaxation.



SUITE BAMBOU

Un coin bambou pour un se détendre en toute tranquillité.

GAZEBO

Coperture di varie dimensioni in eucalipto, in legno, in bambù o altri materiali; finiture con tende in materiale impermeabile e facilmente lavabile. Realizziamo strutture su progettazione in base alle esigenze del cliente.



Coverings in various sizes in eucalyptus, wood, bamboo or other materials and curtains in waterproof, easy care material. We create design based structures according to customers' needs.

Couvertures en plusieurs tailles en eucalyptus, bois, bambou ou autres matériaux et rideaux en matériaux imperméable et facile à entretenir. Nous réalisons structures basés sur conceptions selon les exigences de nos clients.







COSTRUZIONI

Dall'ideazione al prodotto finito, realizziamo i sogni esotici dei nostri clienti.





CONSTRUCTIONS

From design to finished product, we make our clients' exotic dreams come true.

CONSTRUCTION

De la conception au produit fini, nous réalisons les rêves exotiques de nos clients.







COPERTURE TONDE

RO201

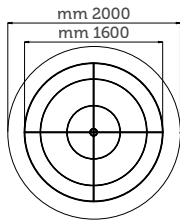

RO211

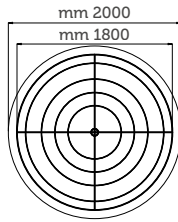

RO201ST

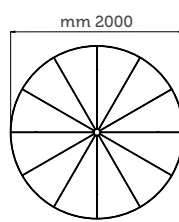

RO233

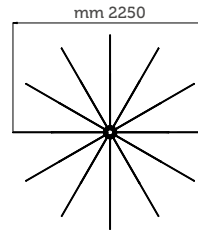

RO230

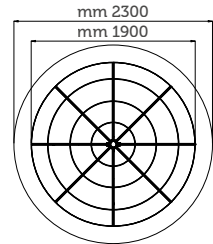

RO250

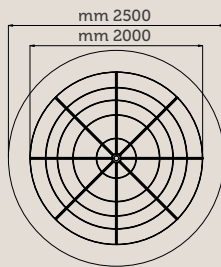

RO250ST

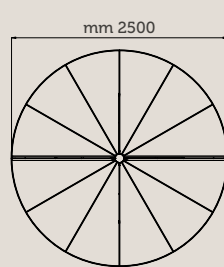

RO280

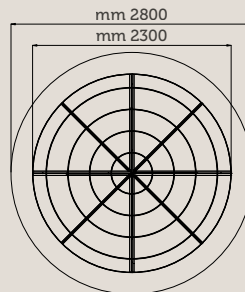

RO330

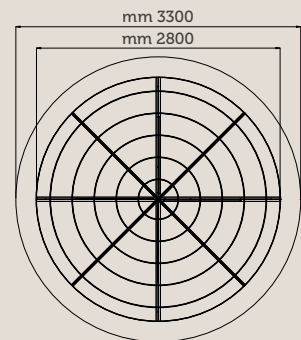

RO381

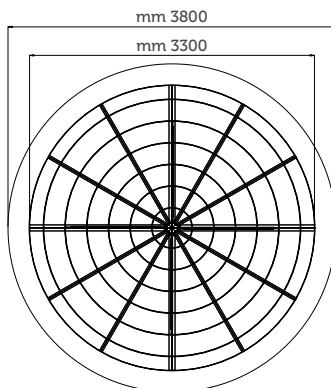

RO430 / RO380ST

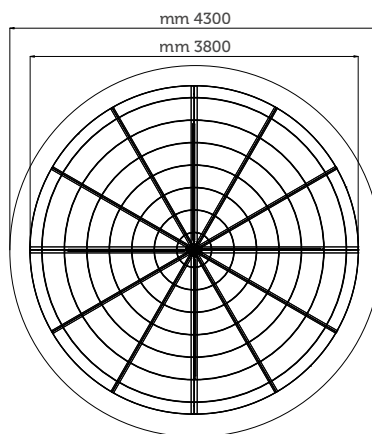

RO501

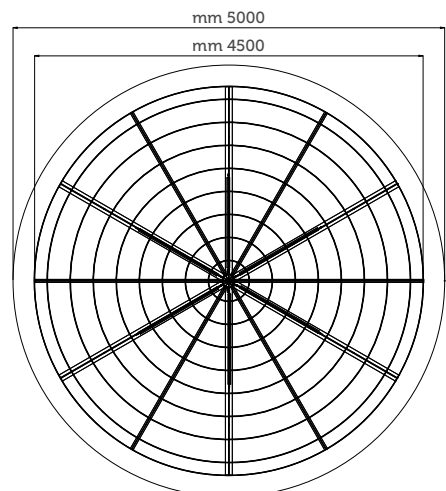

COPERTURE OVALI

OV2338

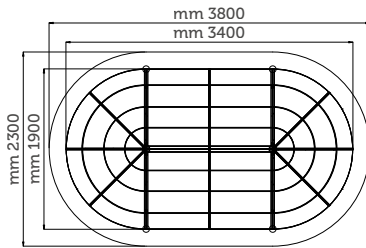

OV2845

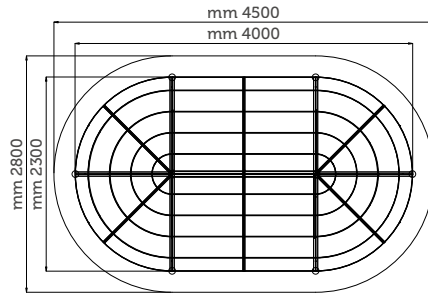

OV3360

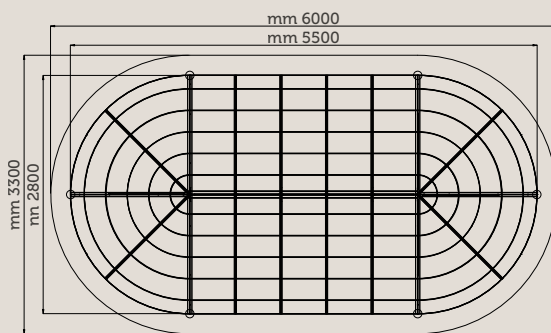

OV3860

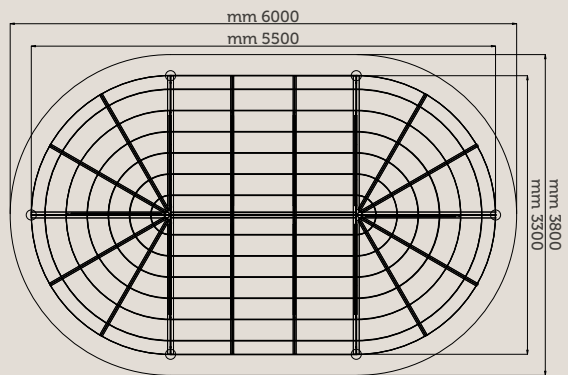

OV4359

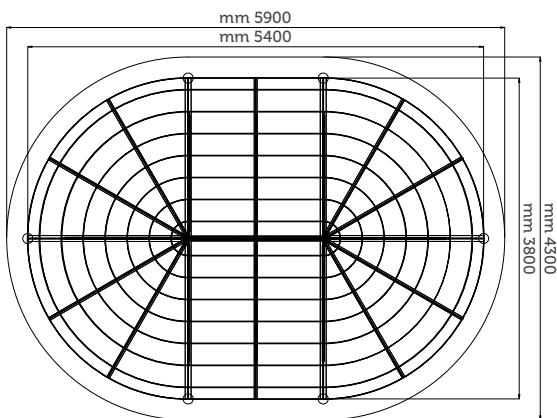

OV5070

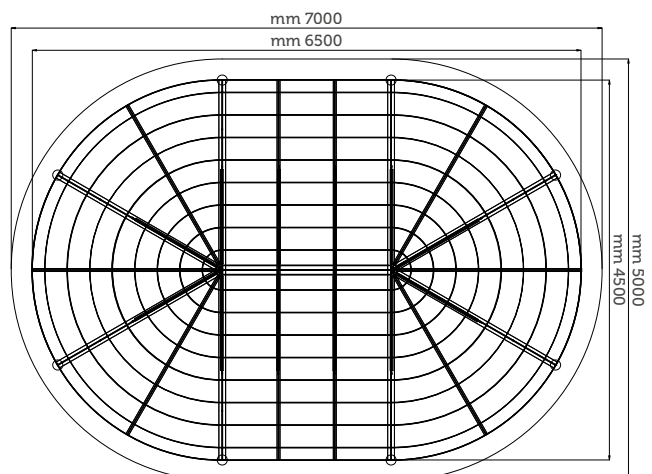

COPERTURE QUADRATE STONDATE

QS250

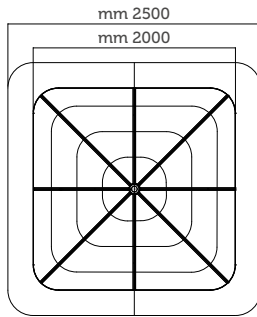

QS300

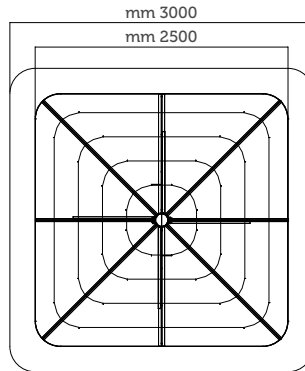

QS400

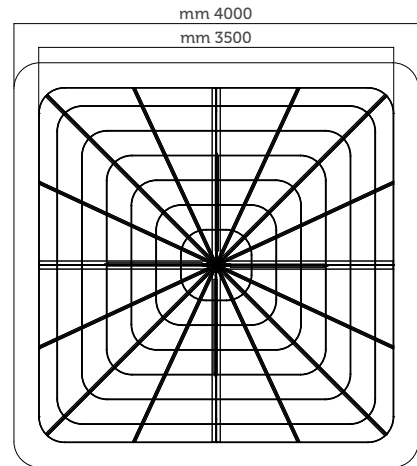

TAVOLI IN LEGNO

COMP001

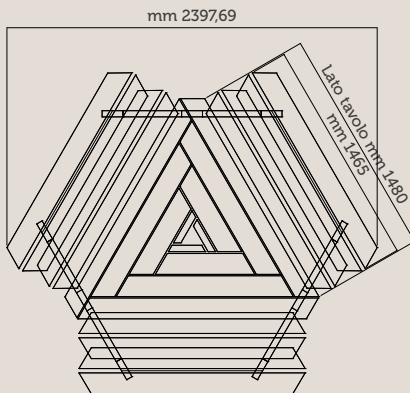

COMP003

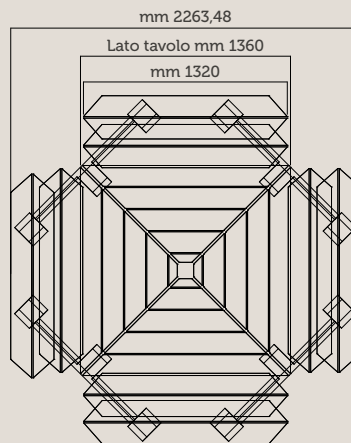

COMP016

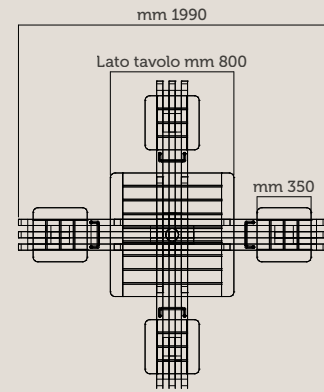

COMP018

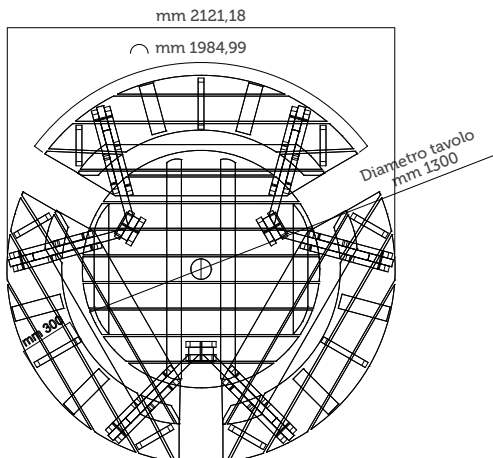

COMP007

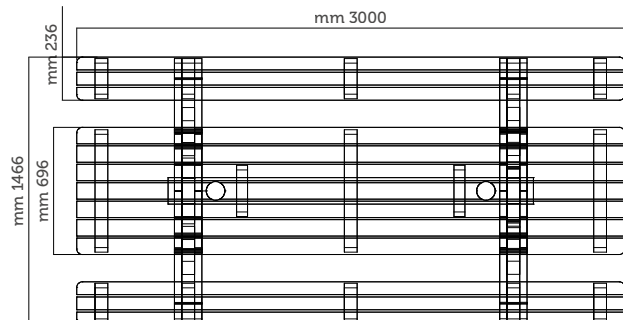

CHIOSCHI E CHIRINGUITOS

COMP201 + RO330

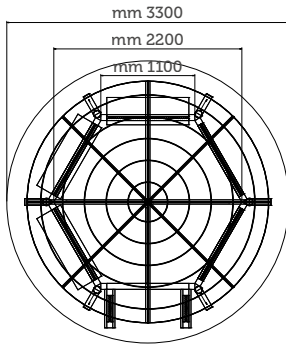

COMP203 + RO380

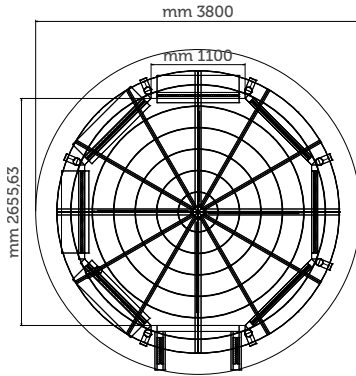

COMP205 + RO500

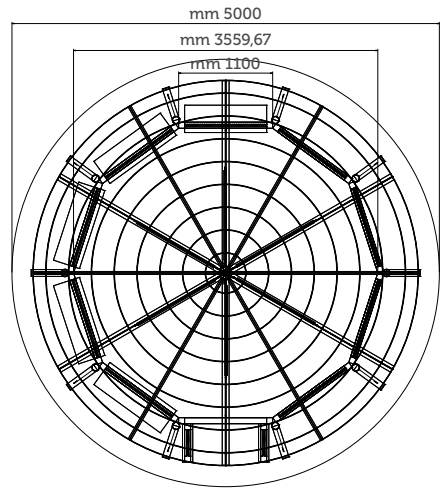

COMP305 + RO500

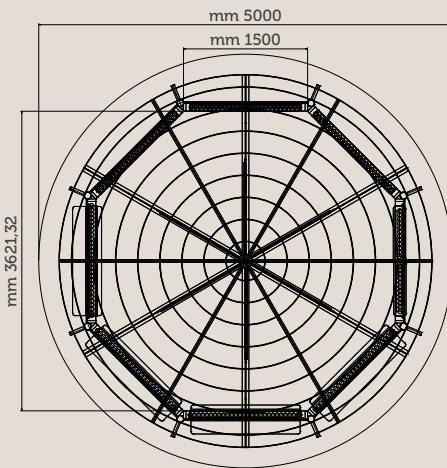

COMP303 + RO380

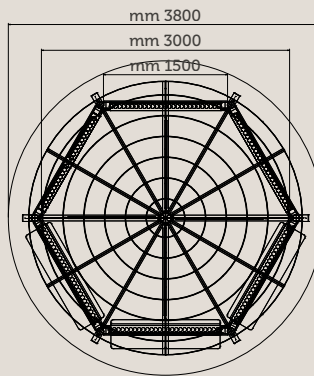

COMP313 + QS400

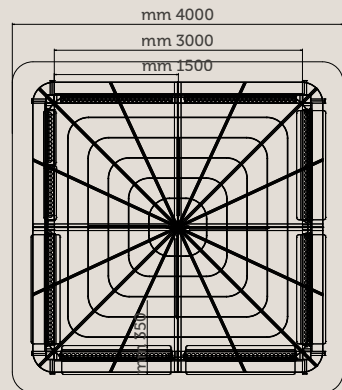

COMP325 + OV4375

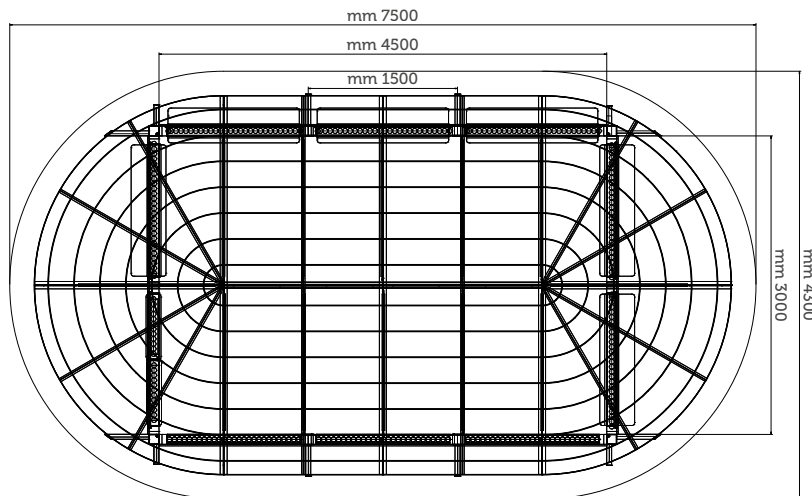

TELEFONO
0039 0424 382821

FAX
0039 0424 391939

MOBILE
0039 348 7303424
0039 348 7303418

info@giostemar.it
www.giostemar.it